

US00D763673S

(12) **United States Design Patent**  
**Moreau et al.**

(10) **Patent No.:** **US D763,673 S**  
(45) **Date of Patent:** **\*\* Aug. 16, 2016**

(54) **BADGE CLIP ASSEMBLY**

(71) Applicant: **Ty-Flot, Inc.**, Manchester, NH (US)

(72) Inventors: **Darrell A. Moreau**, Manchester, NH (US); **Andre W. Moreau**, Spring Hill, FL (US)

(73) Assignee: **Ty-Flot, Inc.**, Manchester, NH (US)

(\*\*) Term: **14 Years**

(21) Appl. No.: **29/515,767**

(22) Filed: **Jan. 27, 2015**

(51) **LOC (10) Cl.** ..... **08-08**

(52) **U.S. Cl.**  
USPC ..... **D8/395**

(58) **Field of Classification Search**  
USPC ..... D8/394–396, 349–356, 373, 400;  
D24/138; D19/68, 99, 100, 65;  
D20/22, 43, 99; D11/215  
CPC ..... H01R 11/11; H01R 11/281; B21C 1/28;  
F16L 23/036; F16L 3/13; F16L 3/1058;  
E04B 2/74; E04B 2/7442; G09F 3/08  
See application file for complete search history.

(56) **References Cited**

**U.S. PATENT DOCUMENTS**

1,792,923	A	*	2/1931	O'Neil	.....	A43C 11/00 24/69 SK
3,595,458	A	*	7/1971	Prigl	.....	B21C 1/28 226/164
3,618,995	A	*	11/1971	McLean	.....	E05C 19/14 292/113
D261,102	S	*	10/1981	Hoover	.....	294/86.4
D313,205	S	*	12/1990	Mejias	.....	D11/215
D333,775	S	*	3/1993	Krape	.....	D8/331
D391,895	S	*	3/1998	Anscher	.....	D11/215
D432,402	S	*	10/2000	Hyp	.....	D8/383
D454,292	S	*	3/2002	Plummer	.....	D8/331
D464,994	S	*	10/2002	Rosen	.....	D19/65
D467,973	S	*	12/2002	Rosen	.....	D19/65
D477,987	S	*	8/2003	Adams	.....	D19/65
D557,746	S	*	12/2007	Hammar	.....	D20/43
D683,653	S	*	6/2013	Moreau	.....	D11/215

D699,100	S	*	2/2014	Moreau	.....	D8/394
D714,125	S	*	9/2014	Seiders	.....	D8/331
2005/0151367	A1	*	7/2005	Packard	.....	B42D 15/0086 281/21.1

**FOREIGN PATENT DOCUMENTS**

JP	D1260464	*	1/2006
JP	D1260465	*	1/2006

**OTHER PUBLICATIONS**

Other Latch Clamps | DE-STA-CO, online, website copyright 2016, <http://www.destaco.com/other-latch-clamps.html>, [site visited Jan. 28, 2016 7:37:53 PM].\*

Baumgartens Sicurix Button ID Badge Straightap Clips—Walmart.com, online, customer review date Jul. 23, 2014, <http://www.walmart.com/ip/Baumgartens-BAU68010-I.D.-Strap-Clip-Adapter-Pack-of-25/> . . . , site visited Feb. 6, 2016.\*

\* cited by examiner

*Primary Examiner* — John Windmuller

*Assistant Examiner* — John R Yeh

(74) *Attorney, Agent, or Firm* — Mesmer & Deleault PLLC

(57) **CLAIM**

The ornamental design for a badge clip assembly, as shown and described.

**DESCRIPTION**

FIG. 1 is a left-side and front perspective view of the badge clip assembly showing our new design in a closed position with a fastener installed in the clip;  
FIG. 2 is a right-side and rear perspective view thereof;  
FIG. 3 is a left-side and front perspective view of the badge clip assembly shown in an open position;  
FIG. 4 is a right-side and rear perspective view thereof shown in the open position and with the fastener separated from the clip;  
FIG. 5 is a left-side elevational view of the badge clip assembly shown in a closed position and with the fastener installed in the clip;  
FIG. 6 is a right-side elevational view of the badge clip assembly shown in a closed position and with the fastener separated from the clip;

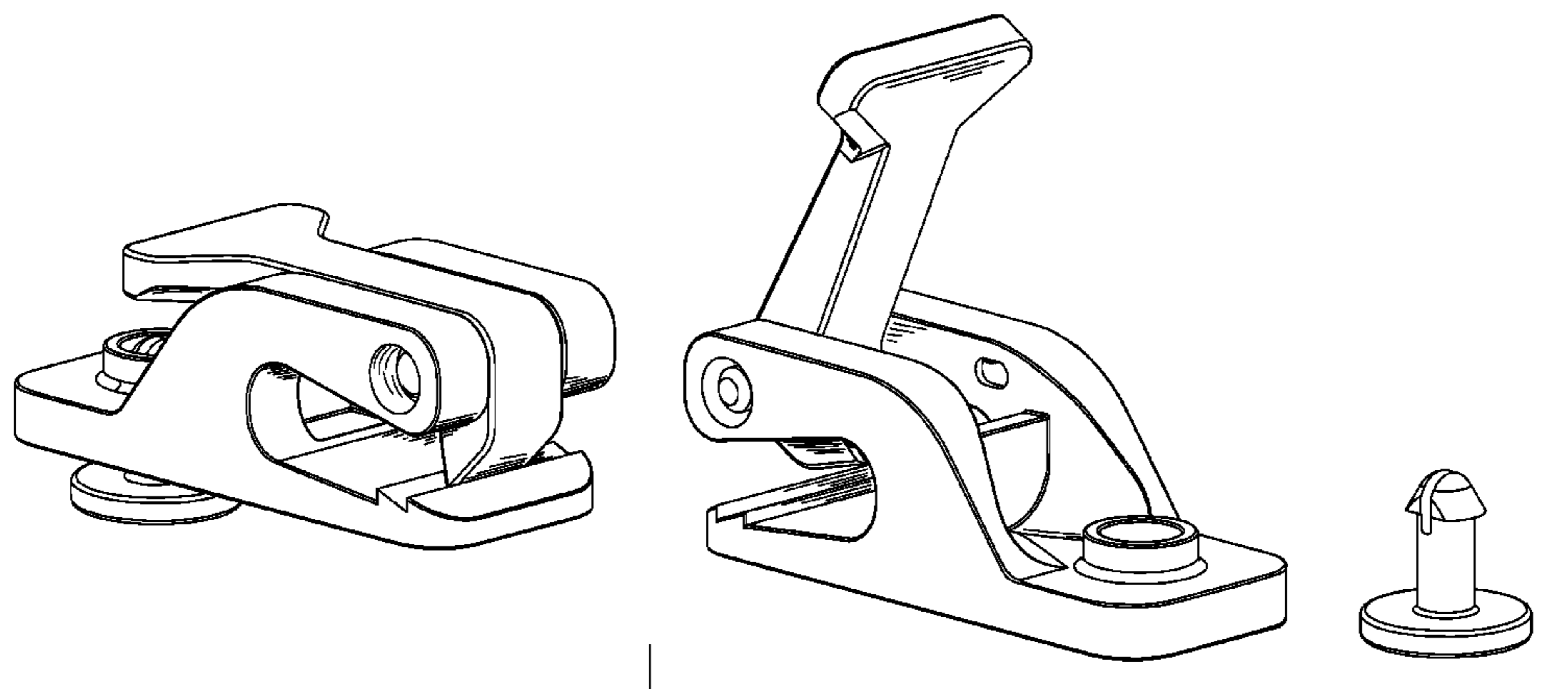

FIG. 7 is a right-side elevational view of the badge clip assembly shown in the open position with the fastener installed in the clip;

FIG. 8 is a left-side elevational view of the badge clip assembly shown in the open position with the fastener installed in the clip;

FIG. 9 is a front elevational view of the badge clip assembly shown in the open position with the fastener installed in the clip;

FIG. 10 is a rear elevational view of the badge clip assembly shown in the closed position with the fastener installed in the clip;

FIG. 11 is a rear elevational view of the badge clip assembly shown in the closed position with the fastener separated from the clip;

FIG. 12 is a front elevational view of the badge clip assembly shown in an open position with the fastener installed in the clip;

FIG. 13 is a front elevational view of the badge clip assembly shown in the closed position with the fastener installed in the clip;

FIG. 14 is a top plan view of the badge clip assembly shown in the closed position with the fastener separated from the clip; and,

FIG. 15 is a bottom plan view of the badge clip assembly with the fastener separated from the clip.

The broken lines illustrate portions of the badge clip assembly that form no part of the claimed design.

**1 Claim, 7 Drawing Sheets**

Fig. 1

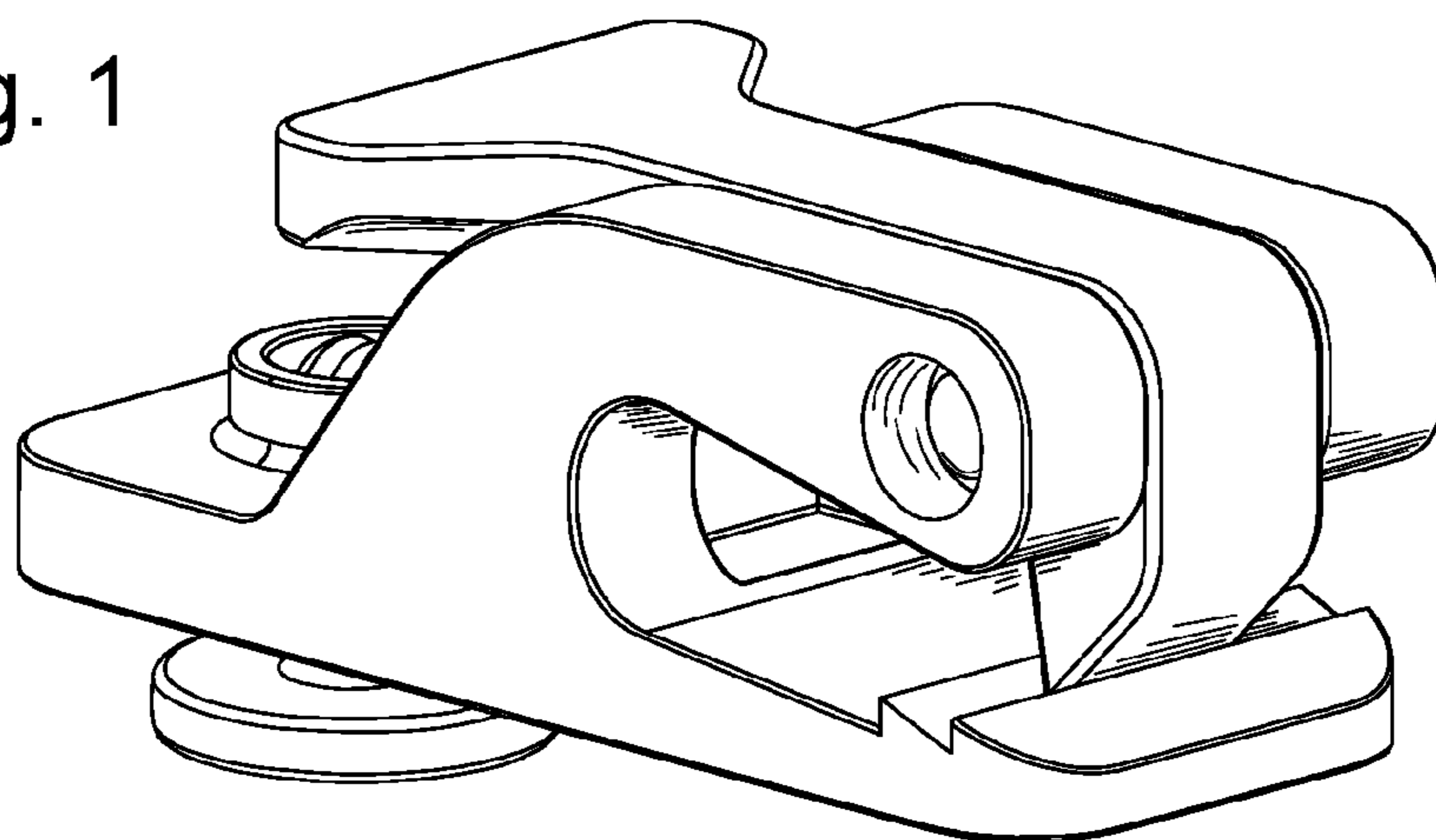

Fig. 2

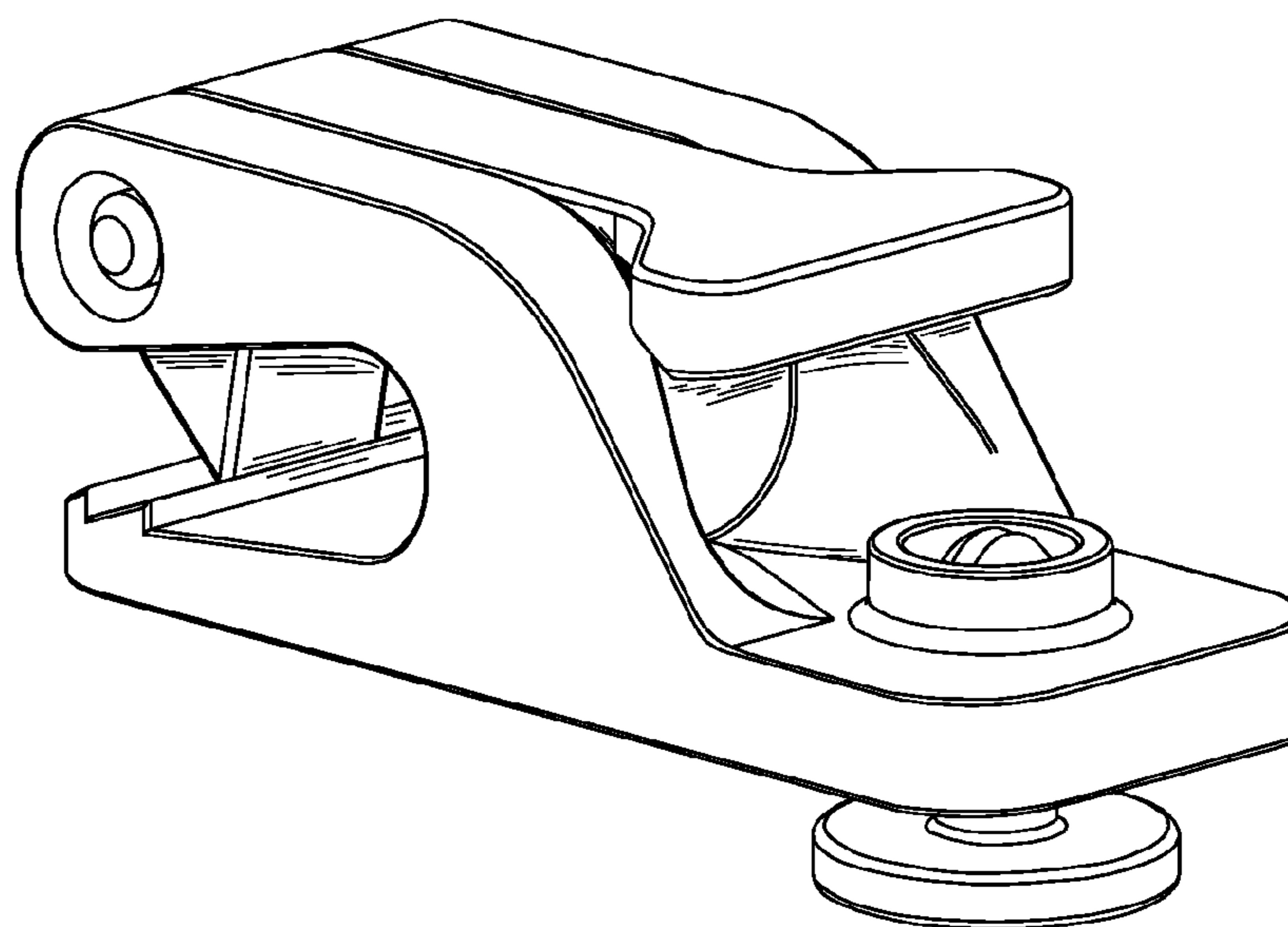

Fig. 3

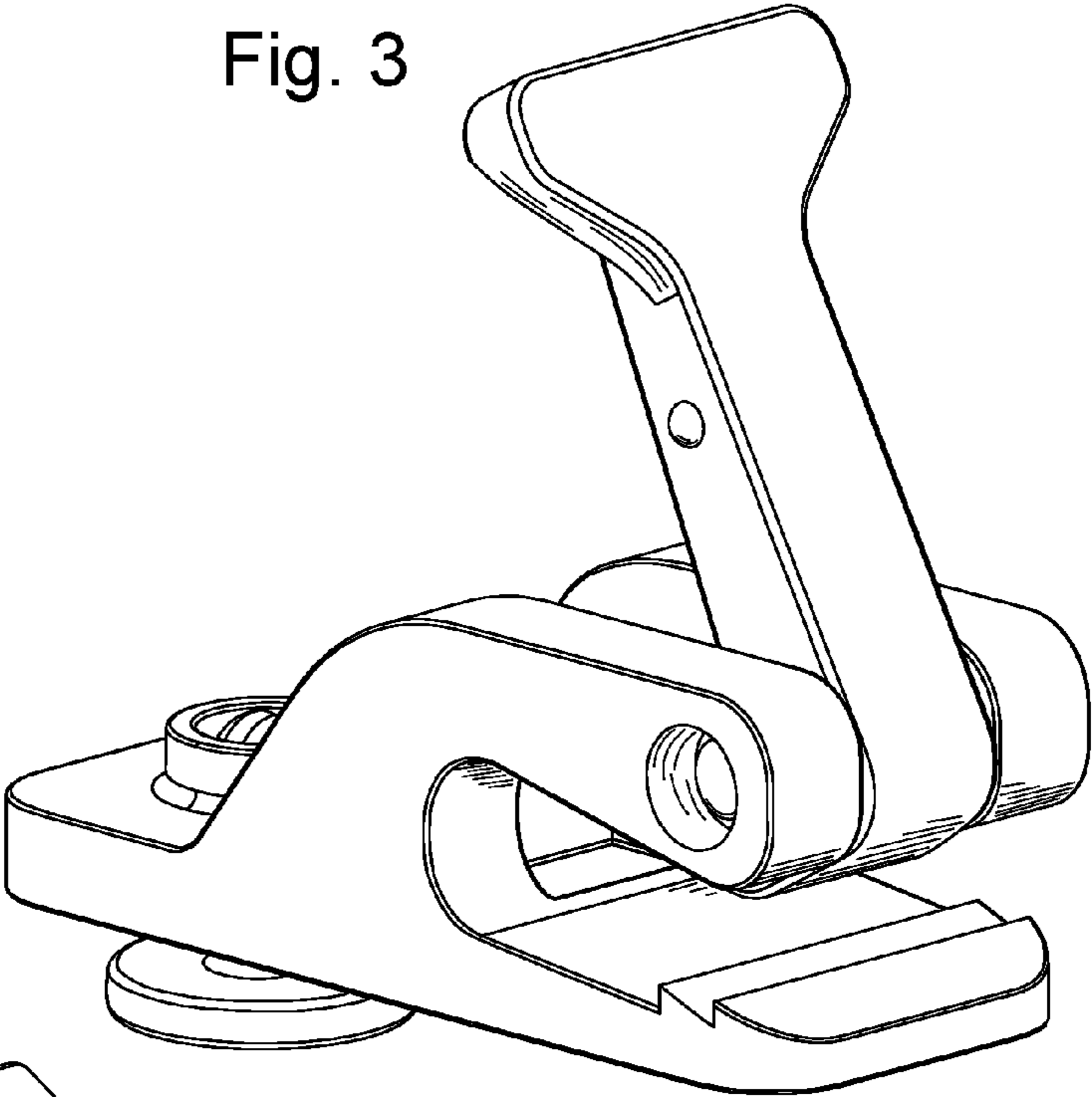

Fig. 4

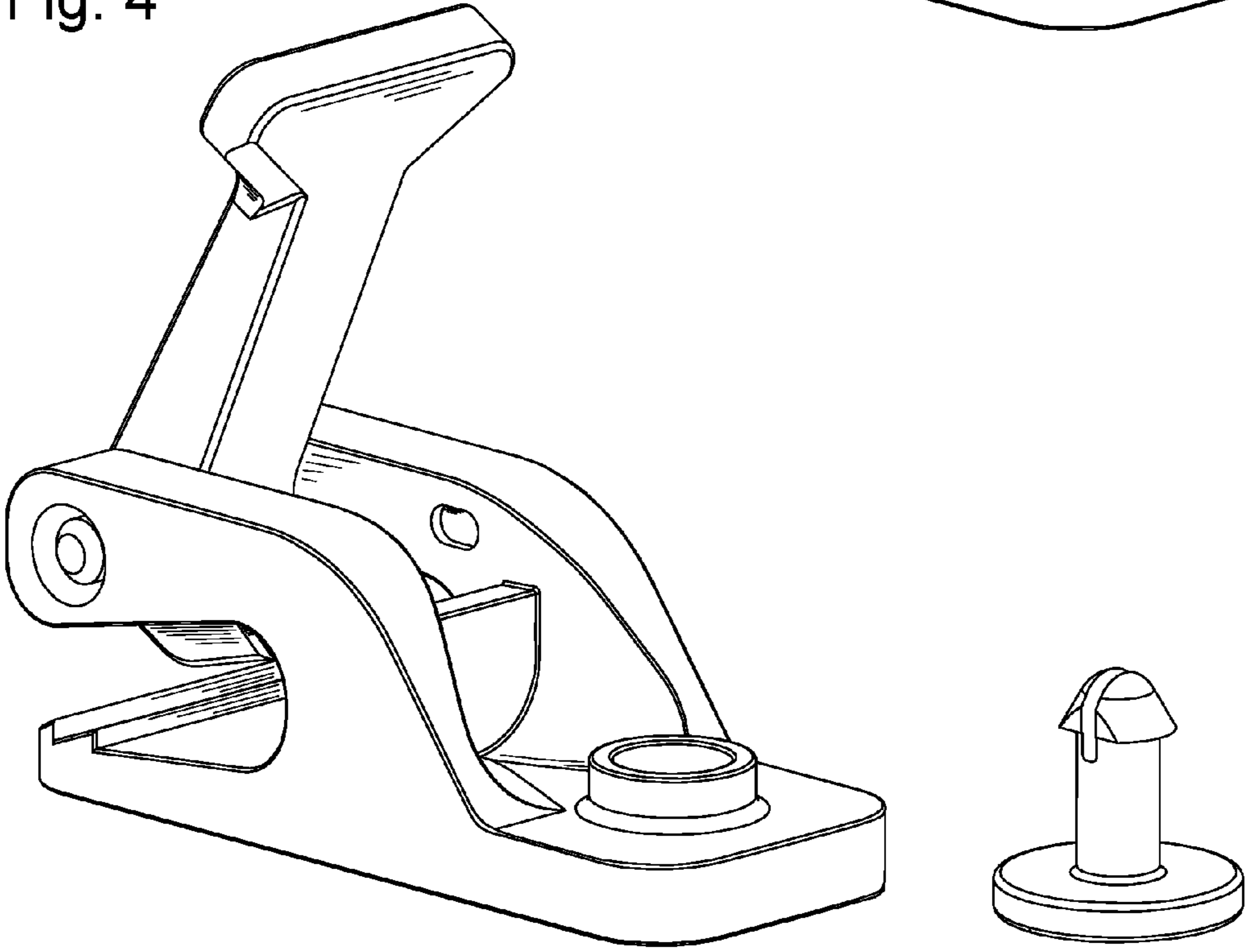

Fig. 5

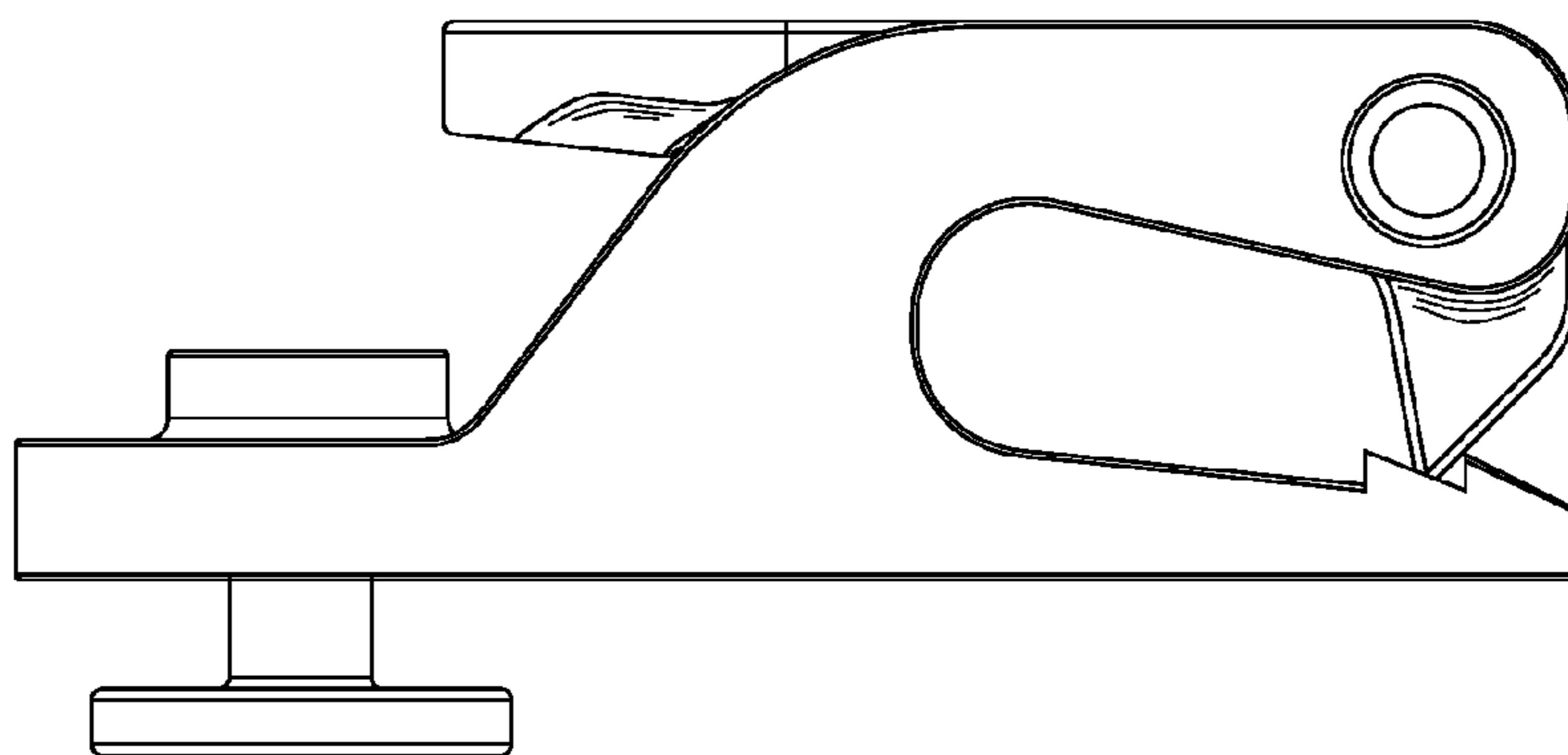

Fig. 6

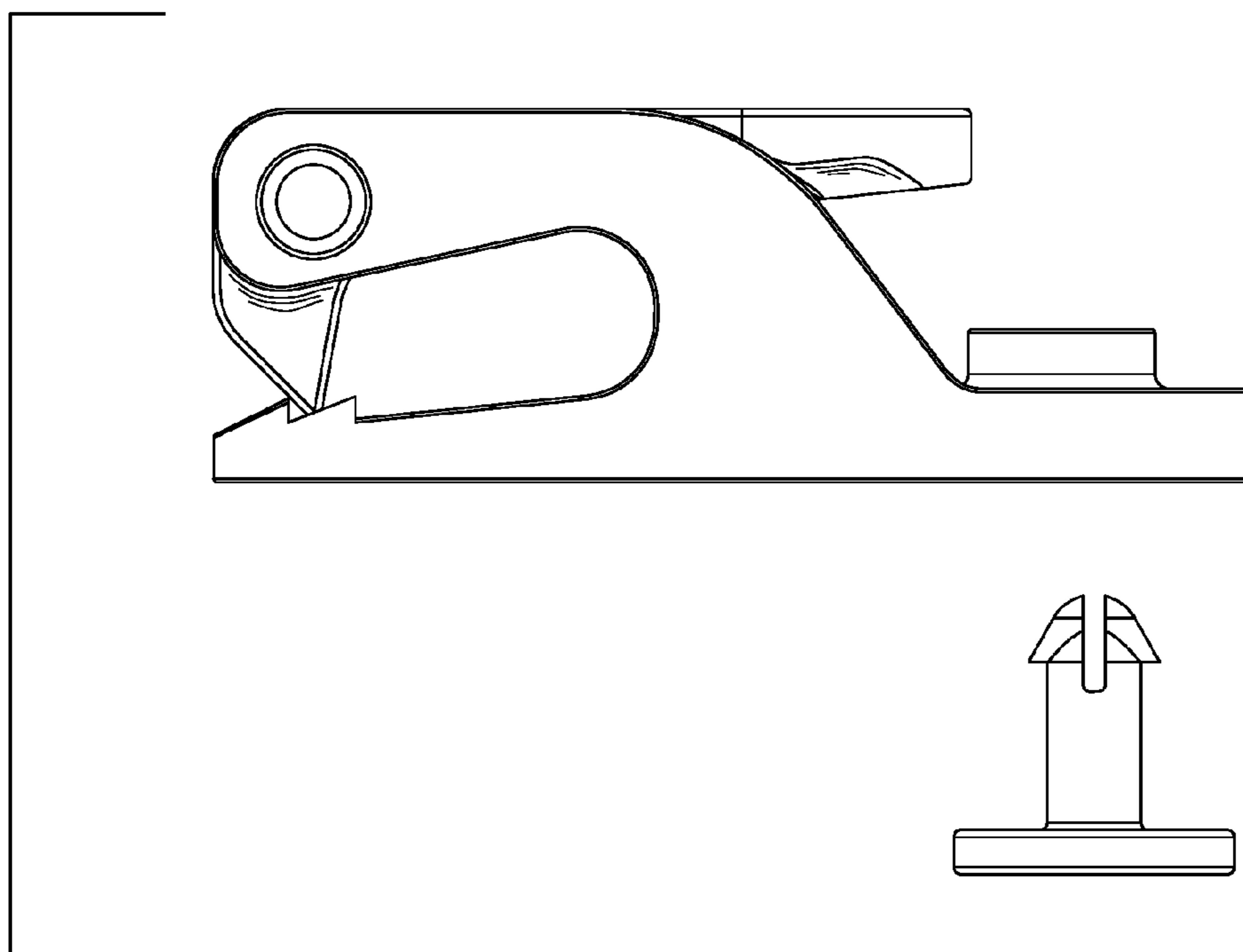

Fig. 7

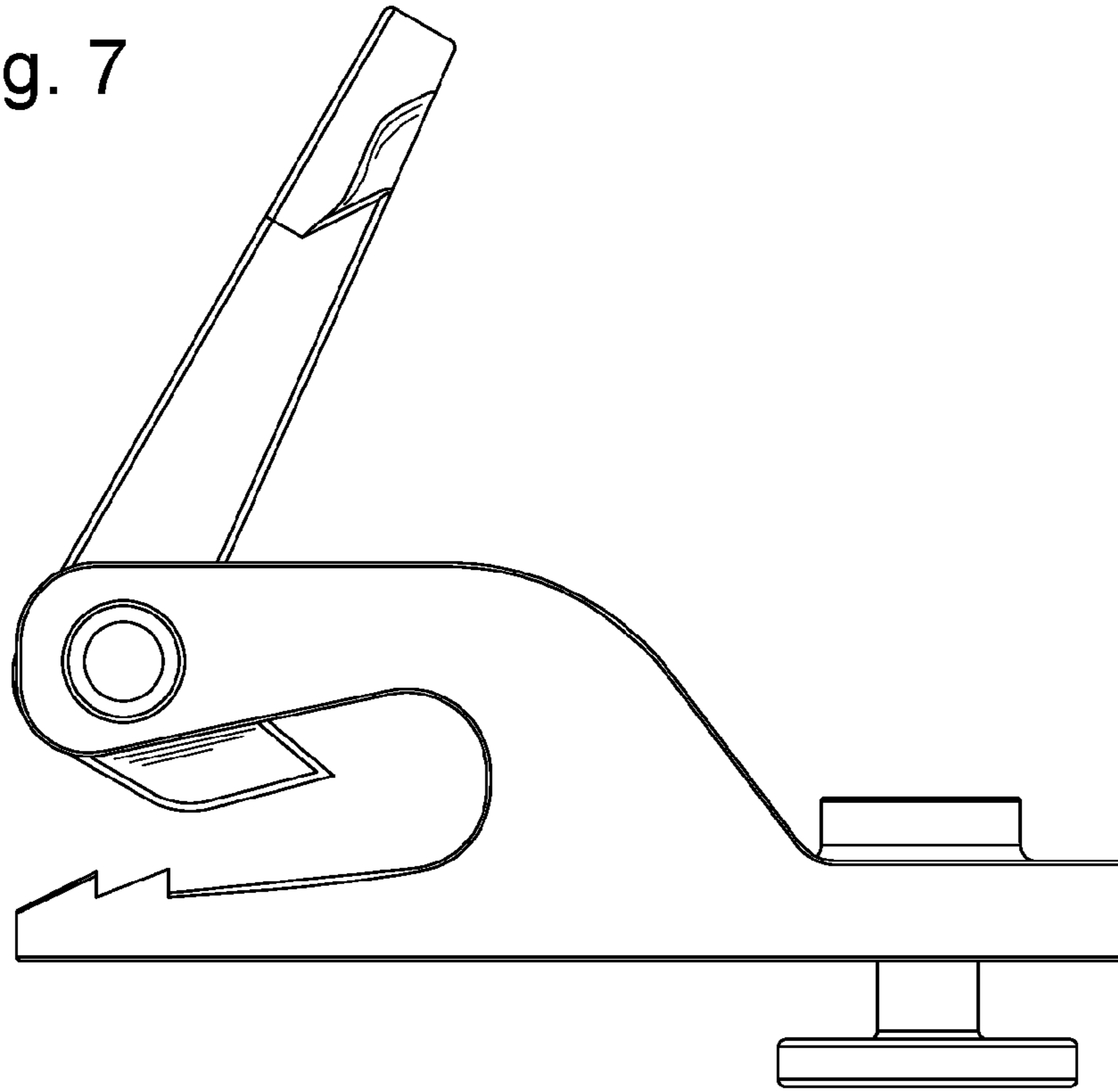

Fig. 8

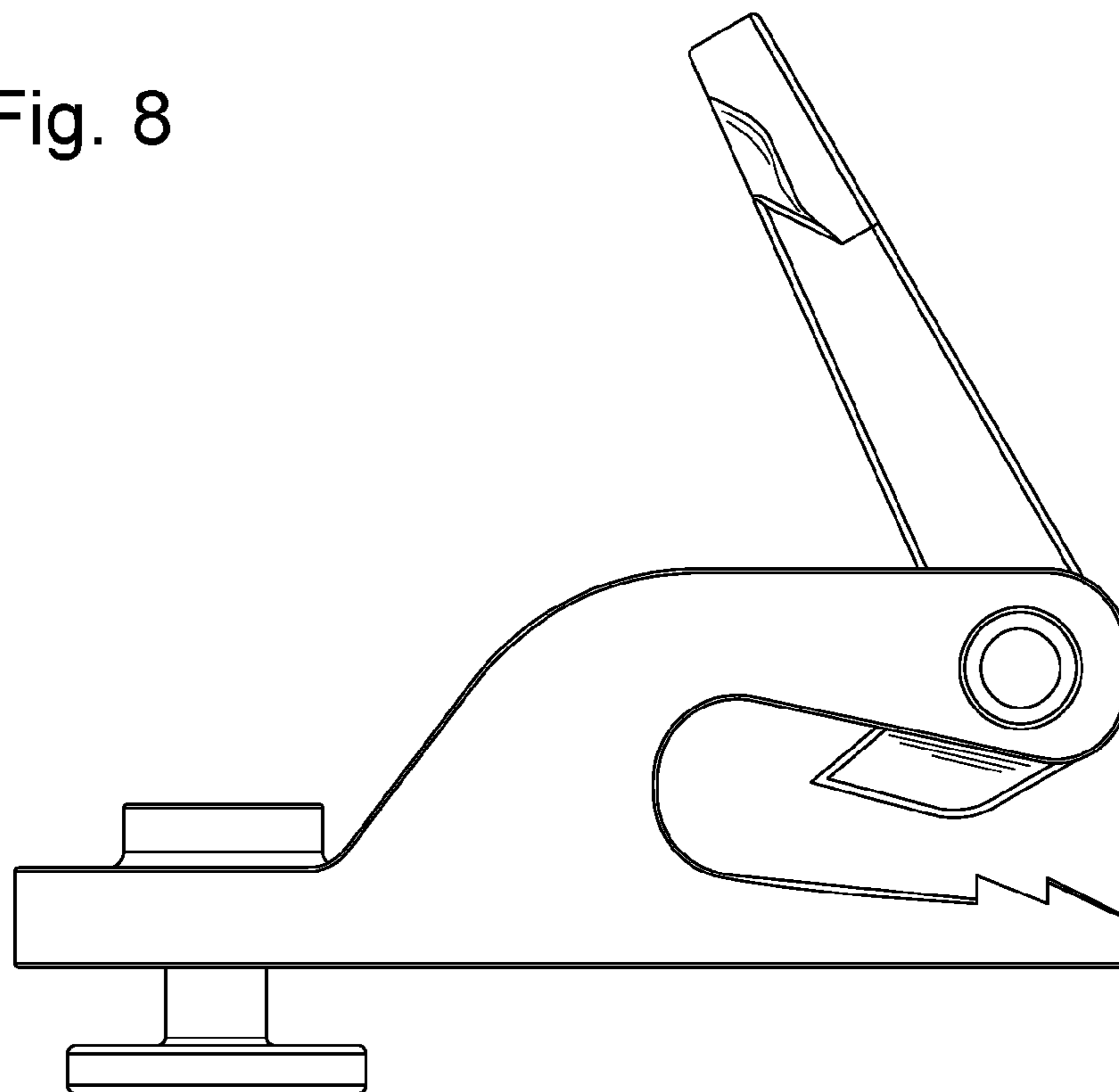

Fig. 9

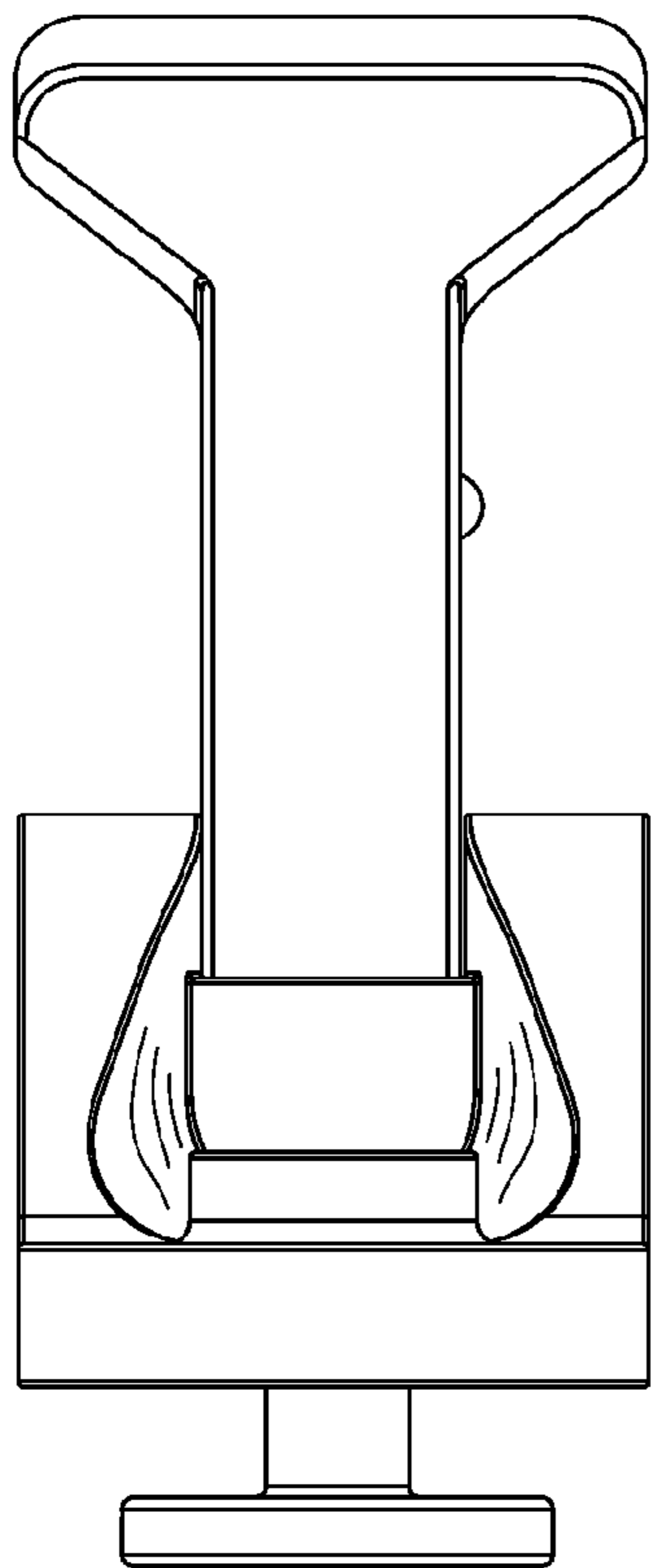

Fig. 10

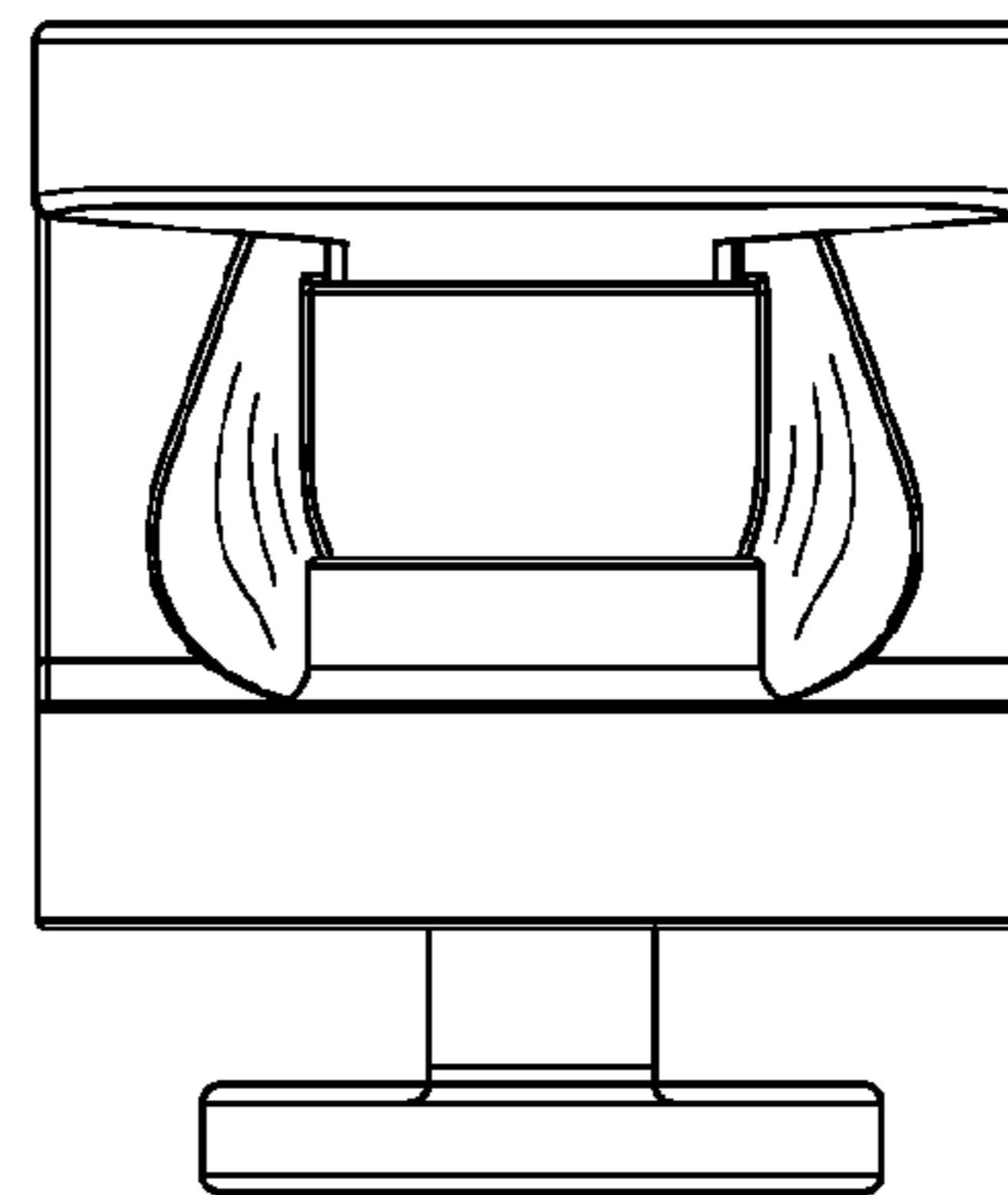

Fig. 11

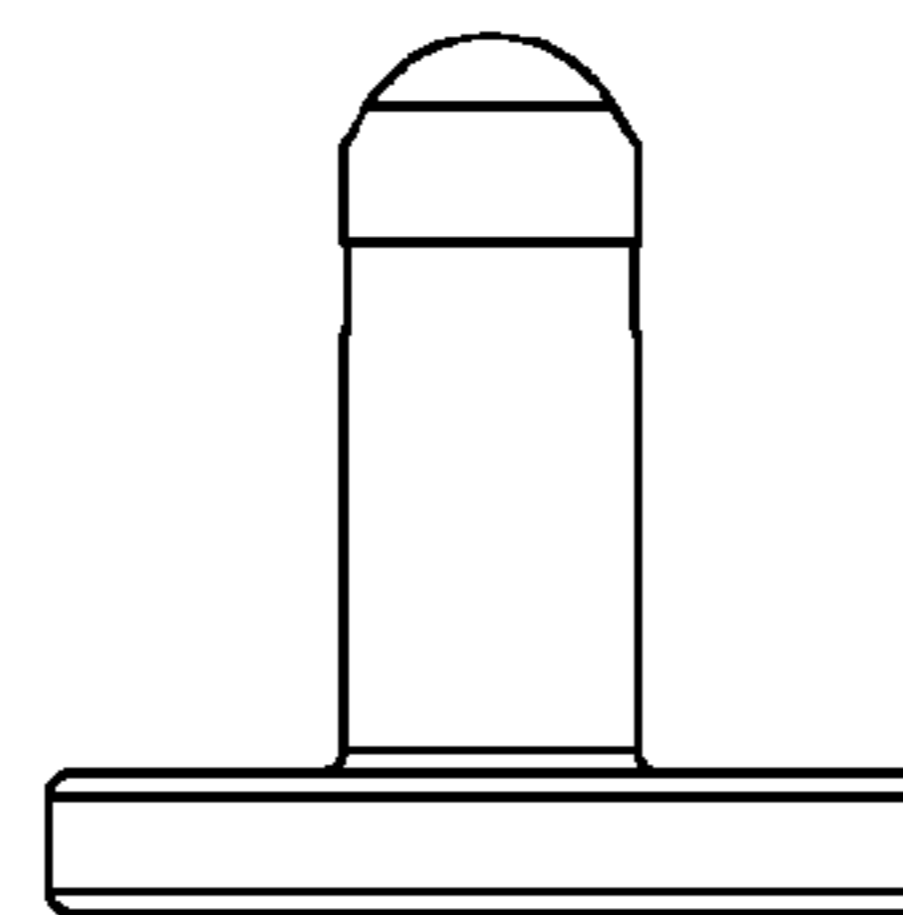
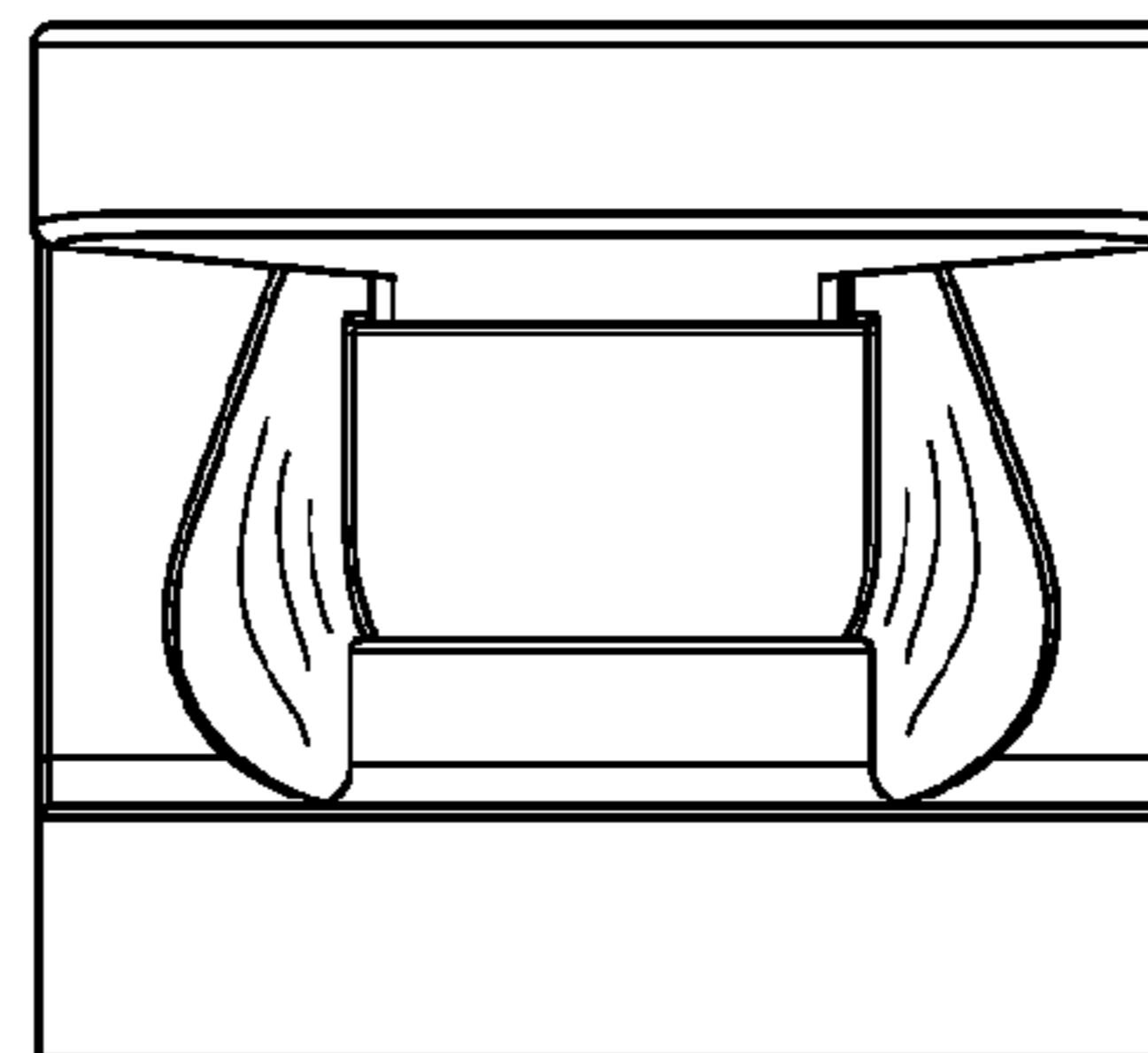

Fig. 12

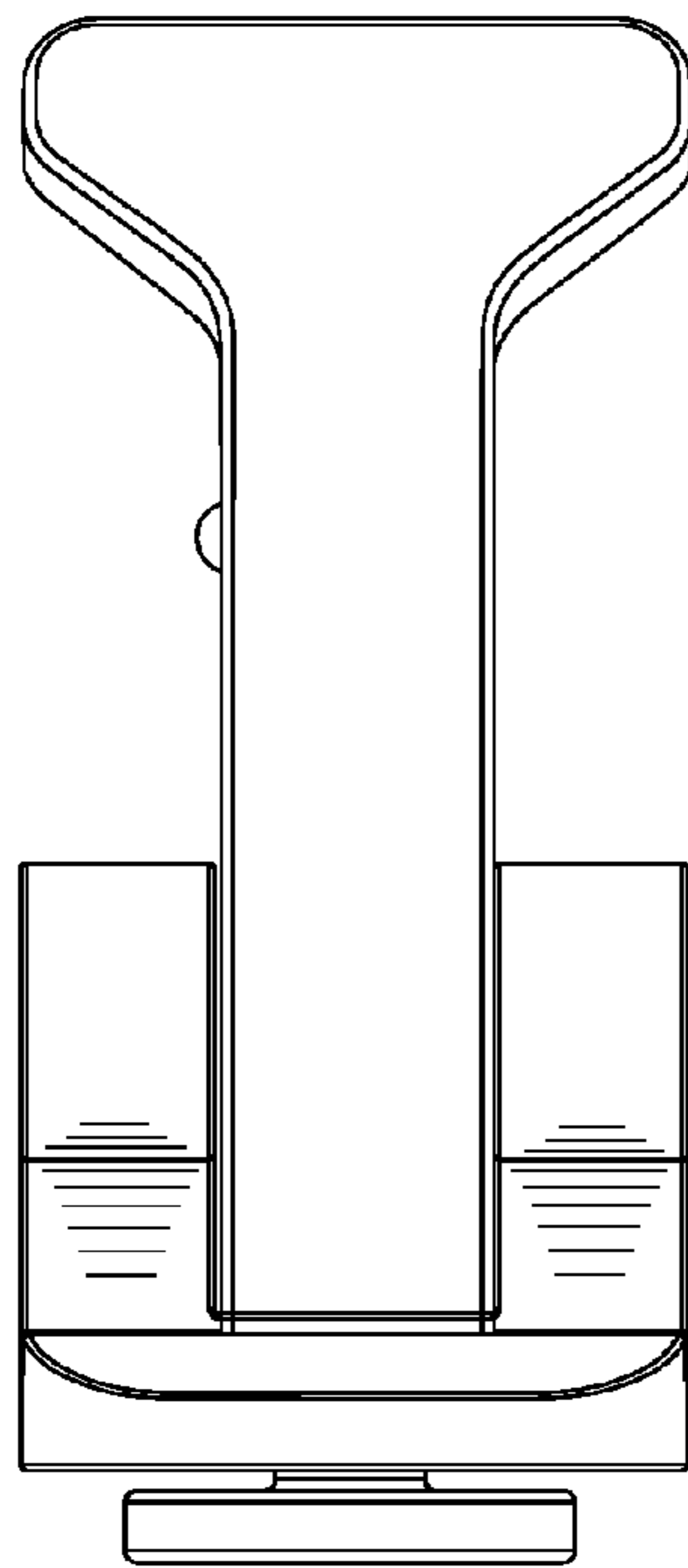

Fig. 13

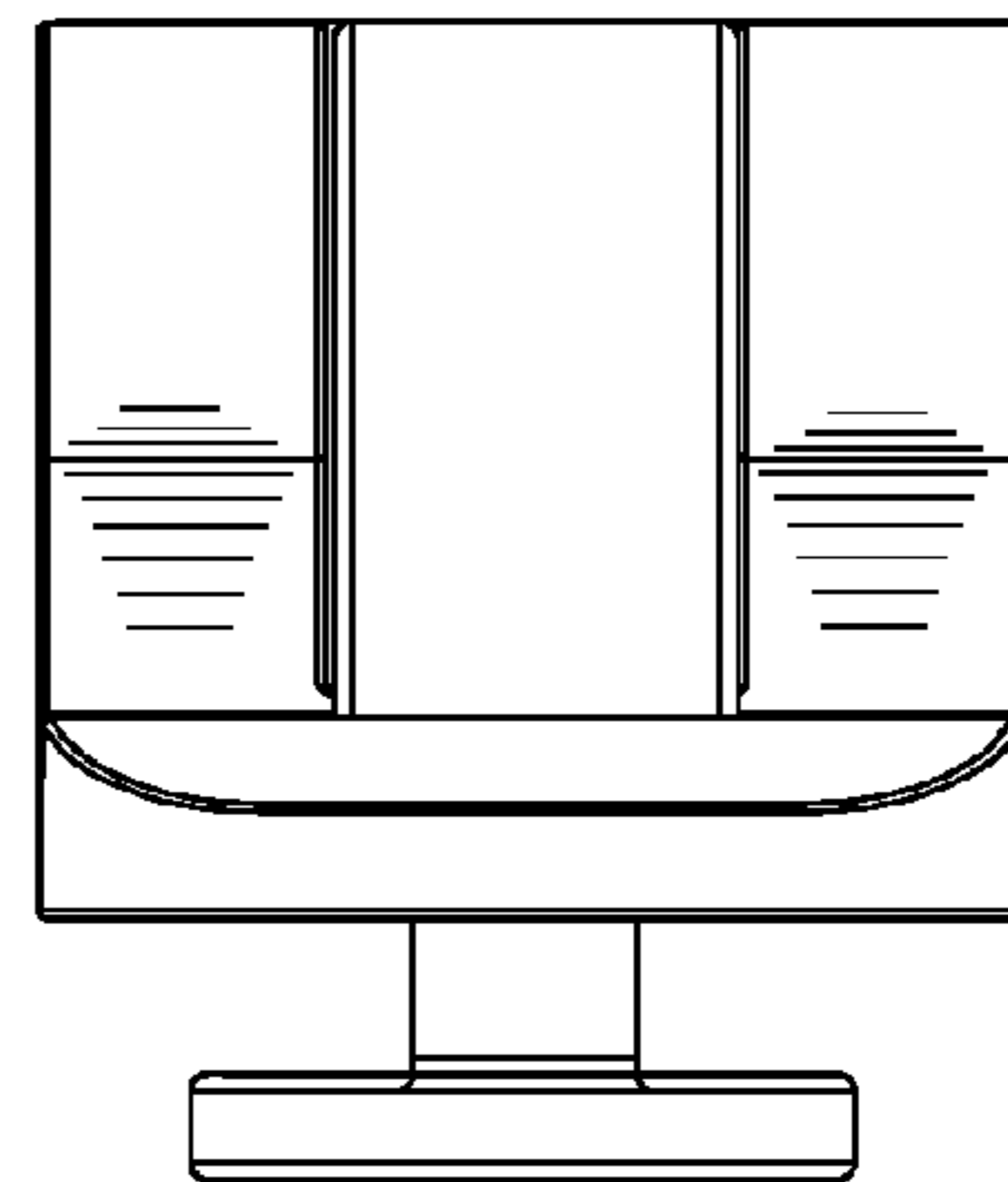



Fig. 14

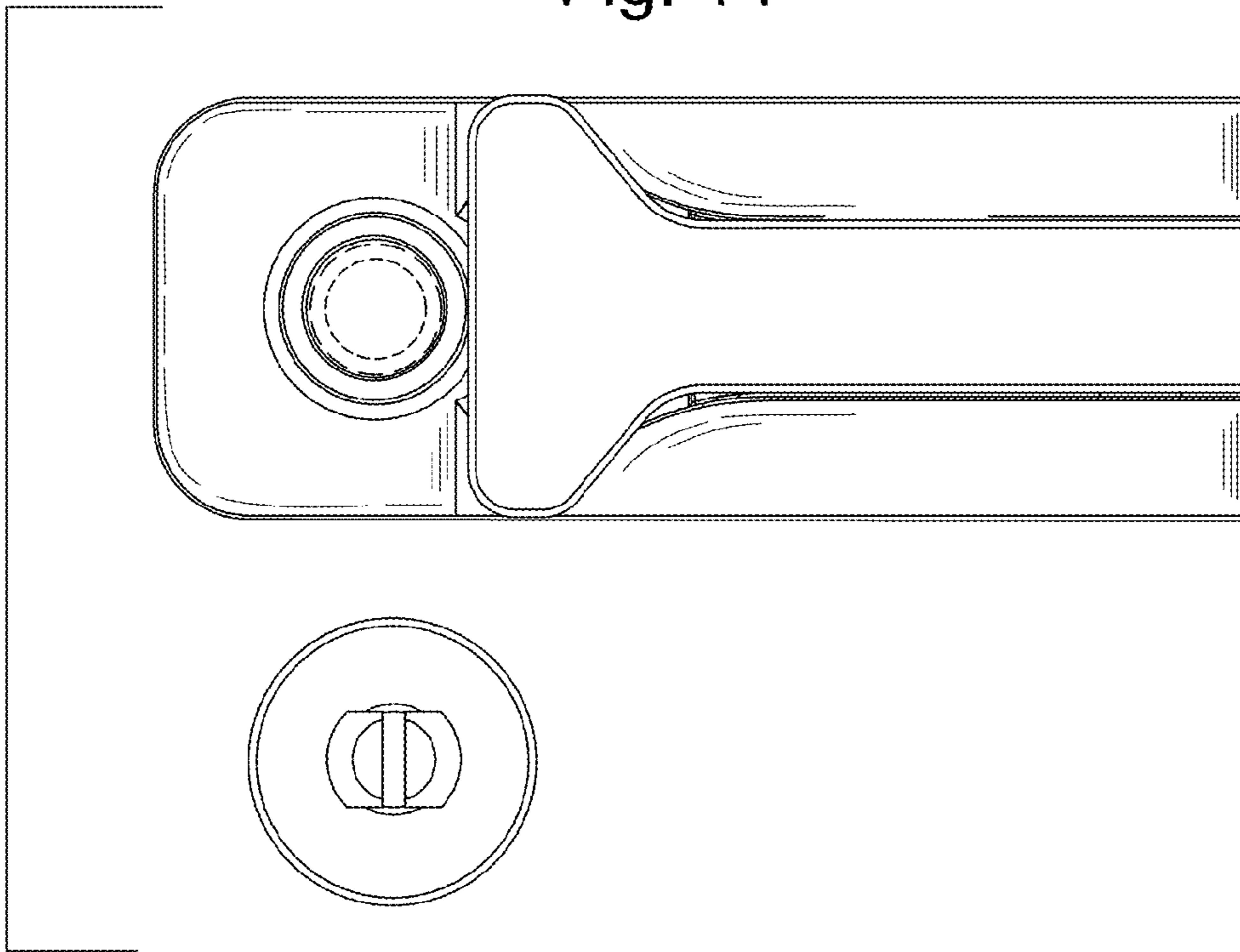

Fig. 15

