



US00D763472S

(12) **United States Design Patent**  
**Watson-Levack**

(10) **Patent No.:** **US D763,472 S**  
(45) **Date of Patent:** **\*\* Aug. 9, 2016**

(54) **LED AND LENS MODULE FOR A STREET LAMP**

(71) Applicant: **Alexander Martin Watson-Levack**,  
Lancashire (GB)

(72) Inventor: **Alexander Martin Watson-Levack**,  
Lancashire (GB)

(\*\*) Term: **14 Years**

(21) Appl. No.: **29/523,310**

(22) Filed: **Apr. 8, 2015**

(30) **Foreign Application Priority Data**

Oct. 27, 2014 (EM) ..... 002564906-0001

(51) **LOC (10) Cl.** ..... **26-04**

(52) **U.S. Cl.**  
USPC ..... **D26/1; D13/180**

(58) **Field of Classification Search**  
USPC ..... D26/1-4; D13/180; 313/313, 315, 316,  
313/317, 318, 493; 315/52, 53, 56, 57, 58  
CPC ..... H01J 5/48; H01J 5/50; H01J 19/54;  
F21V 5/00

See application file for complete search history.

(56) **References Cited**

U.S. PATENT DOCUMENTS

D499,075 S \* 11/2004 Yoon ..... D13/180  
D597,502 S \* 8/2009 Ogata ..... D13/180  
D629,767 S \* 12/2010 Shimizu ..... D13/180  
D697,642 S \* 1/2014 Amari ..... D13/180

\* cited by examiner

*Primary Examiner* — Marcus Jackson

(74) *Attorney, Agent, or Firm* — Egbert Law Offices, PLLC

(57) **CLAIM**

The ornamental design for an LED and lens module for a street lamp, as shown and described.

**DESCRIPTION**

FIG. 1 is a perspective view of an LED and lens module for a street lamp showing my new design.

FIG. 2 is a plan view thereof;

FIG. 3 is a side view thereof;

FIG. 4 is an opposite side view thereof;

FIG. 5 is an end view thereof; and,

FIG. 6 is an opposite end view thereof.

The broken line showing in FIGS. 1-6 is for the purpose of illustrating that the outer portion of the LED and lens module for a street lamp has no specific length or width and forms no part of the claimed design.

**1 Claim, 4 Drawing Sheets**

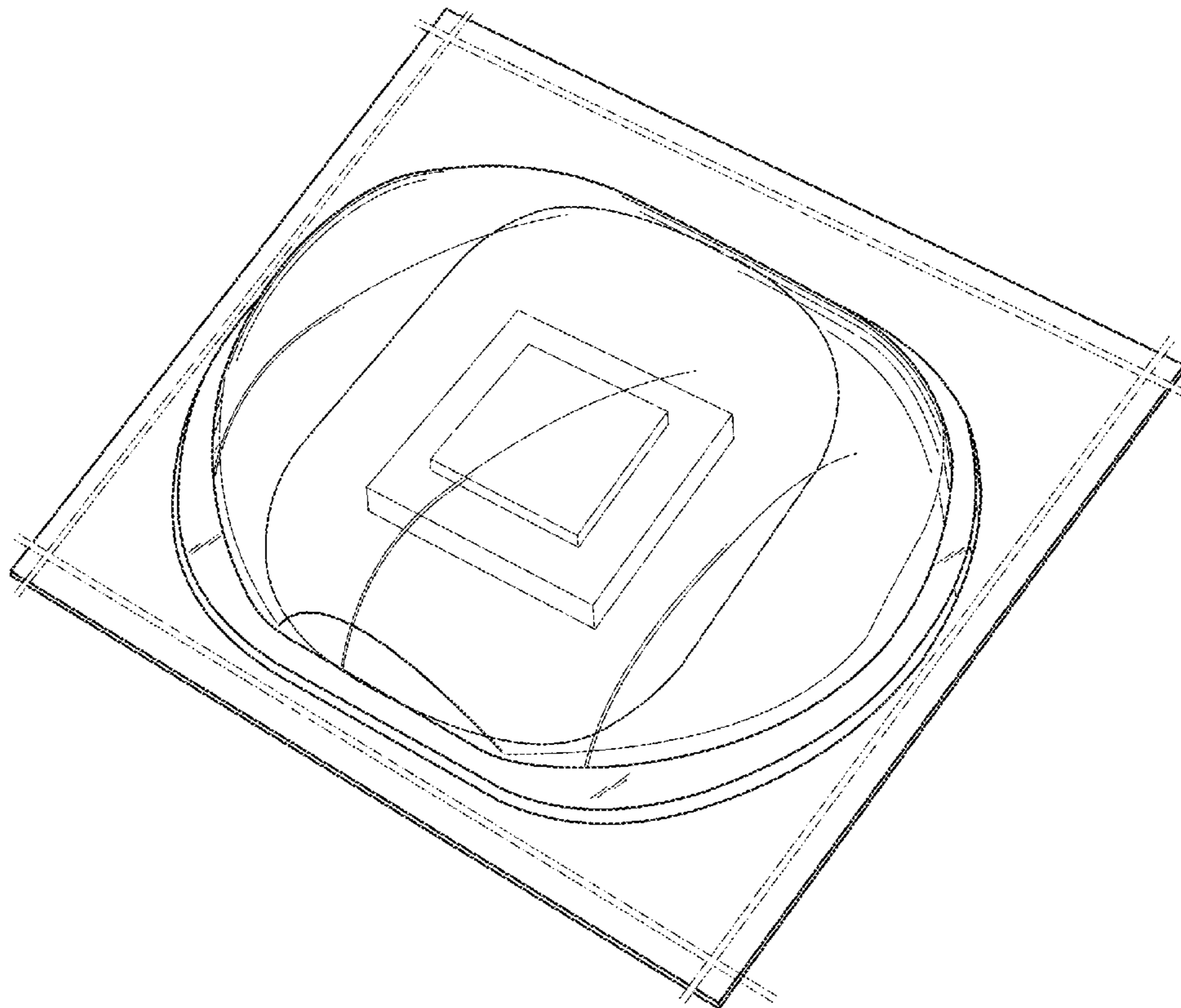

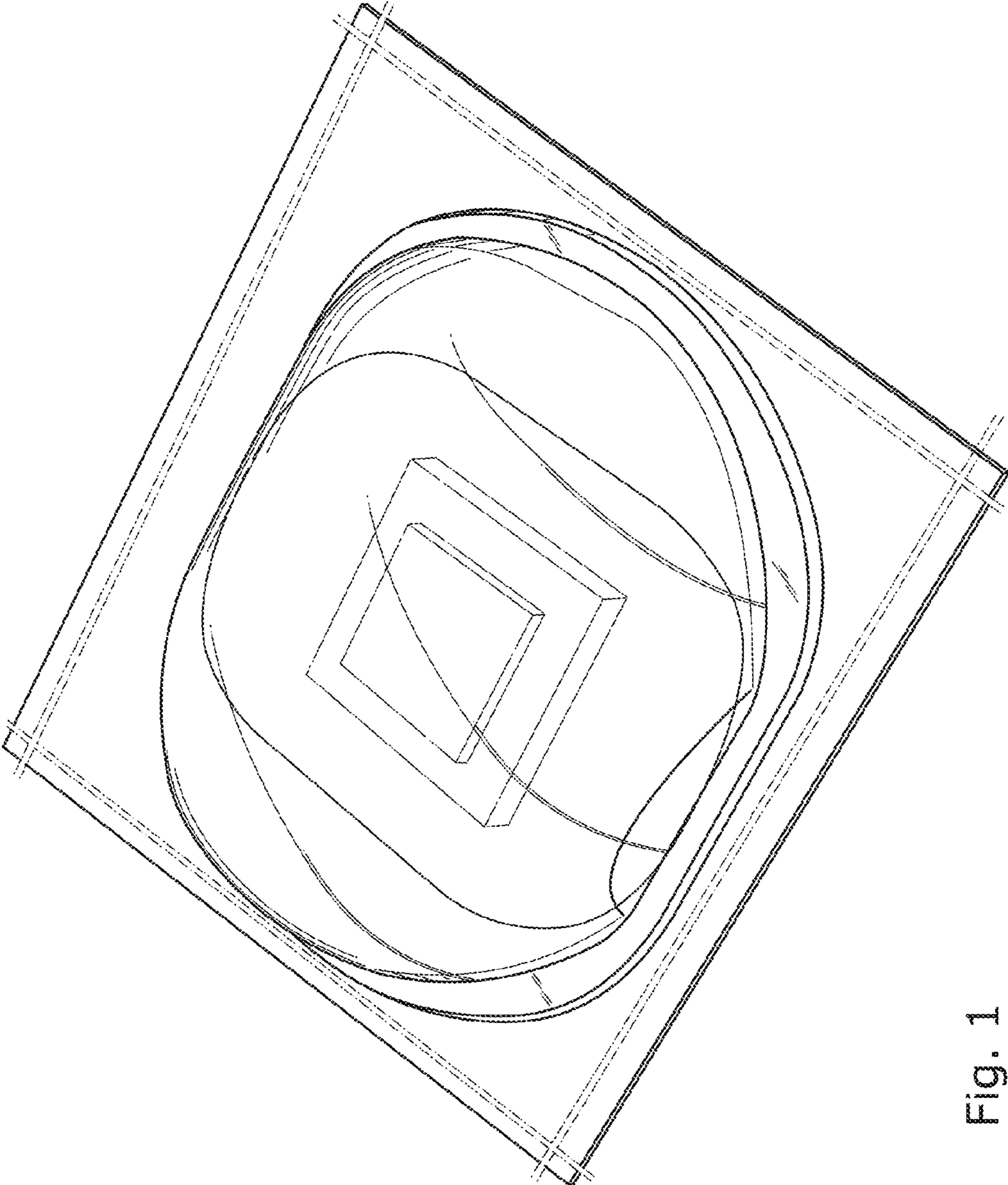

Fig. 1

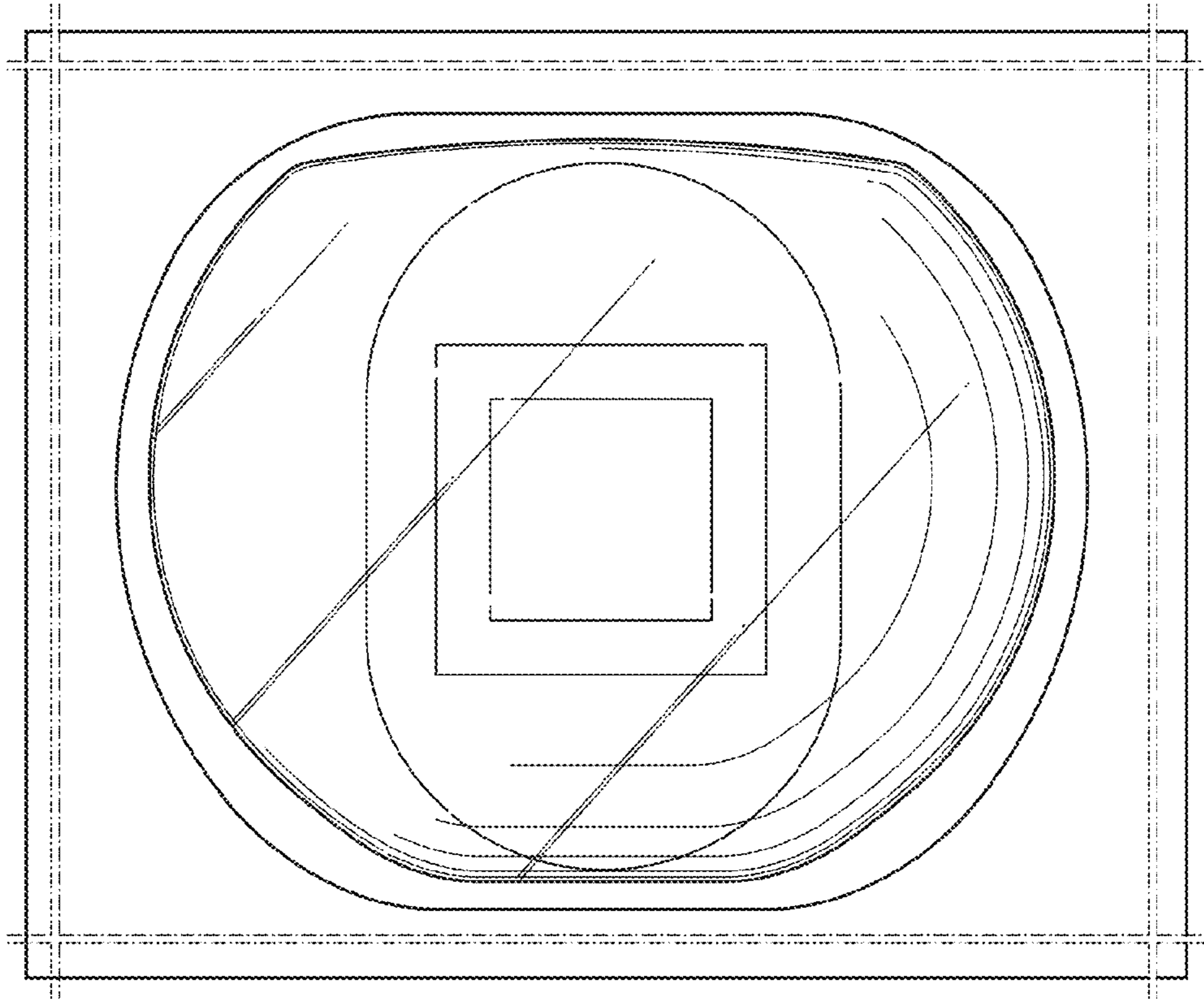

Fig. 2

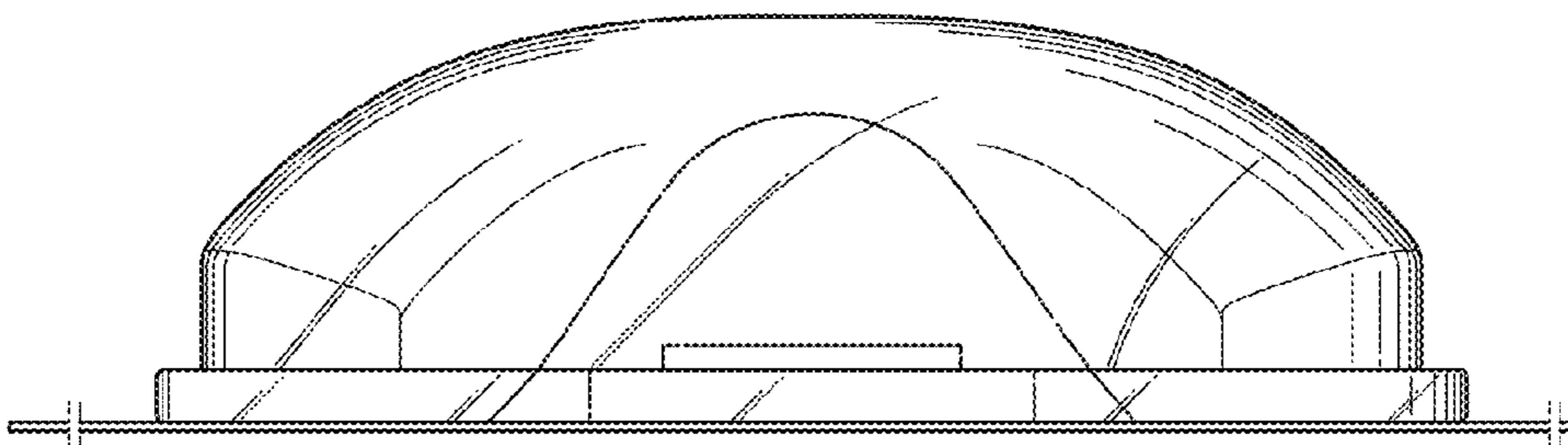

Fig. 3

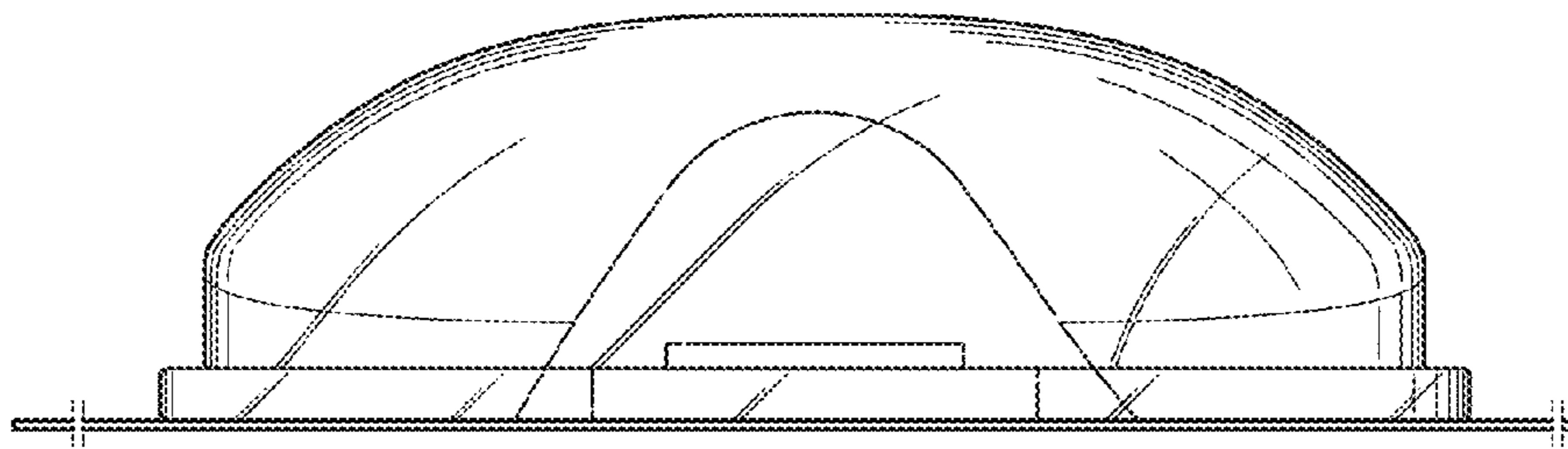

Fig. 4

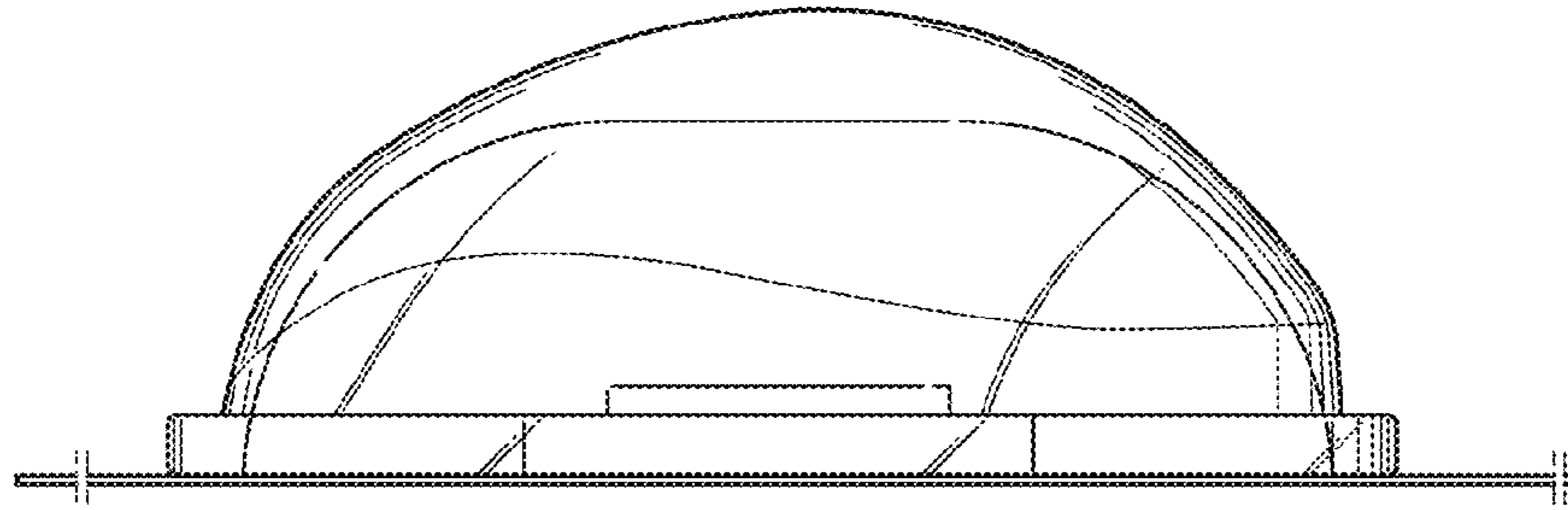

Fig. 5

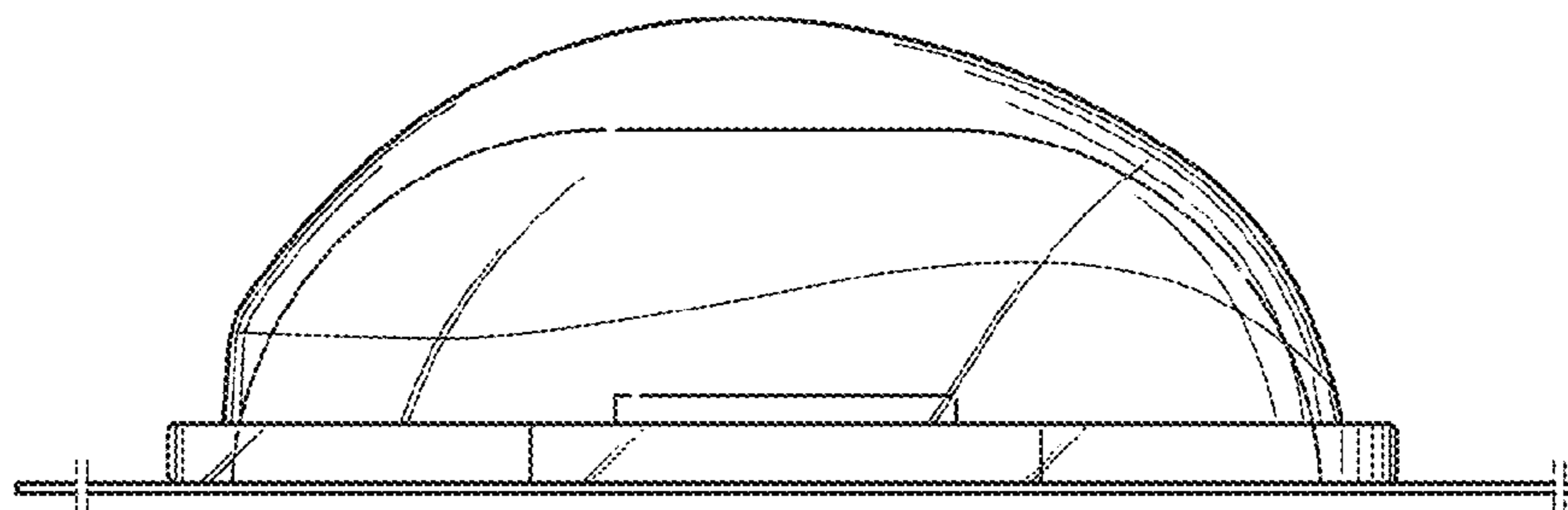

Fig. 6