

US00D763409S

(12) **United States Design Patent**  
**Cox**

(10) **Patent No.:** **US D763,409 S**

(45) **Date of Patent:** **\*\* Aug. 9, 2016**

- (54) **FUEL PRESSURE REGULATOR**
- (71) Applicant: **Aeromotive, Inc.**, Lenexa, KS (US)
- (72) Inventor: **Jared J. Cox**, Overland Park, KS (US)
- (73) Assignee: **AEROMOTIVE, INC.**, Lenexa, KS (US)
- (\*\*) Term: **14 Years**
- (21) Appl. No.: **29/522,683**
- (22) Filed: **Apr. 1, 2015**
- (51) **LOC (10) Cl.** ..... **23-01**
- (52) **U.S. Cl.**  
USPC ..... **D23/235**
- (58) **Field of Classification Search**  
USPC ..... D23/233-250; 137/505.41, 505.39,  
137/454.2, 457, 463, 271, 382, 505, 539,  
137/510, 12, 505.42, 565.11; 123/457, 511,  
123/446, 188.1; 285/187  
CPC ..... F02M 37/0029; F02M 37/0058; F02M  
21/0239; F02M 37/0023; F16K 15/046;  
F16K 15/026; F16K 47/08; F16K 15/044  
See application file for complete search history.

5,265,644 A	11/1993	Tuckey	
5,381,816 A	1/1995	Alsobrooks et al.	
5,409,035 A	4/1995	Scott et al.	
5,579,739 A	12/1996	Tuckey et al.	
5,785,023 A	7/1998	Cross	
D410,525 S *	6/1999	Uehara .....	D23/235
6,056,009 A	5/2000	Powell et al.	
6,298,828 B1	10/2001	Concialdi	
D622,288 S *	8/2010	Miller .....	D15/5
D623,272 S *	9/2010	Cavagna .....	D23/233
D623,273 S *	9/2010	Cavagna .....	D23/233
D628,274 S *	11/2010	Wessol .....	D23/233
2010/0289258 A1 *	11/2010	Cavagna .....	F16L 55/1026 285/187

\* cited by examiner

*Primary Examiner* — Cynthia Ramirez  
*Assistant Examiner* — Gino Colan  
(74) *Attorney, Agent, or Firm* — Erickson Kernell IP, LLC

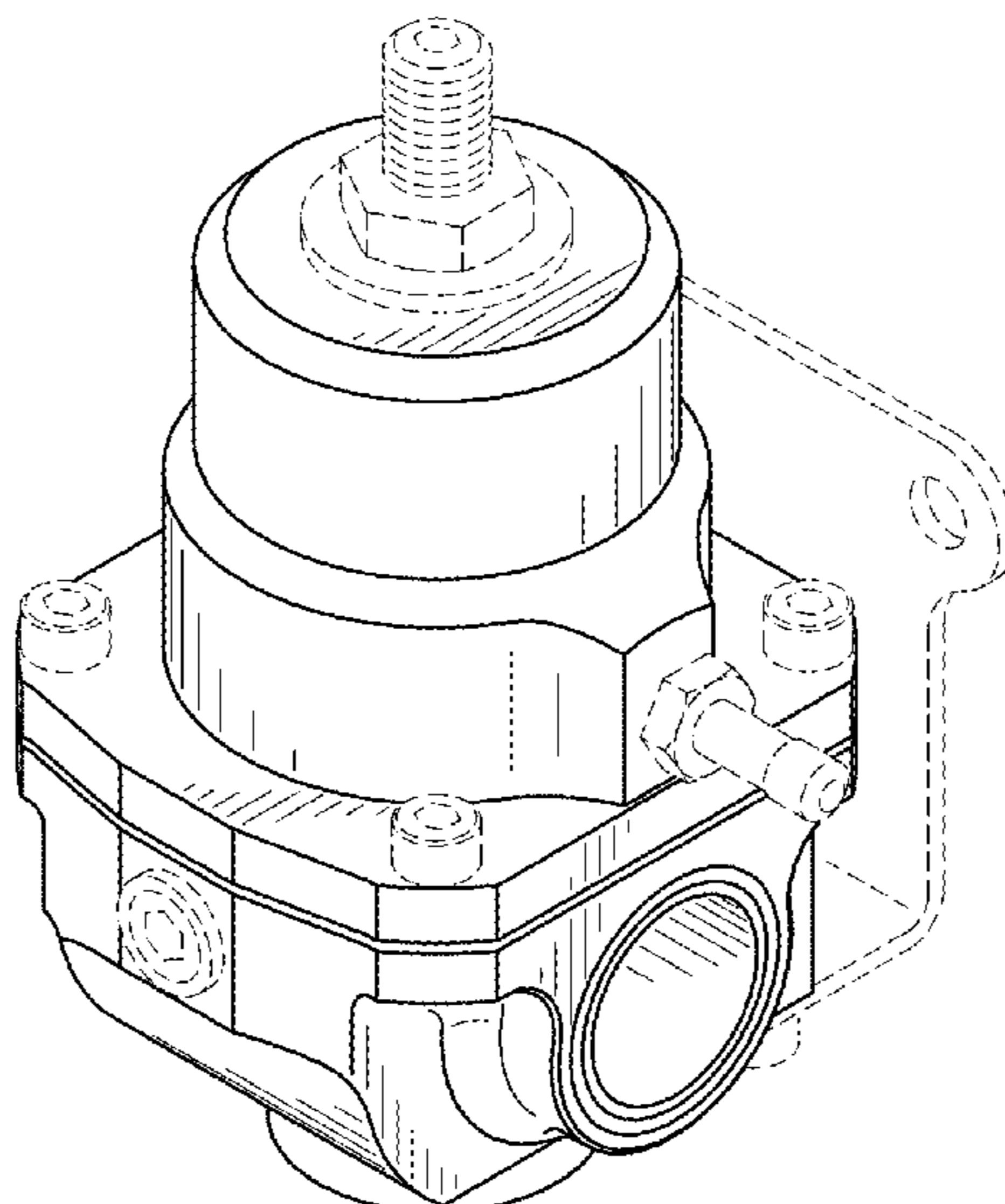
(57) **CLAIM**  
The ornamental design for a fuel pressure regulator, as shown and described.

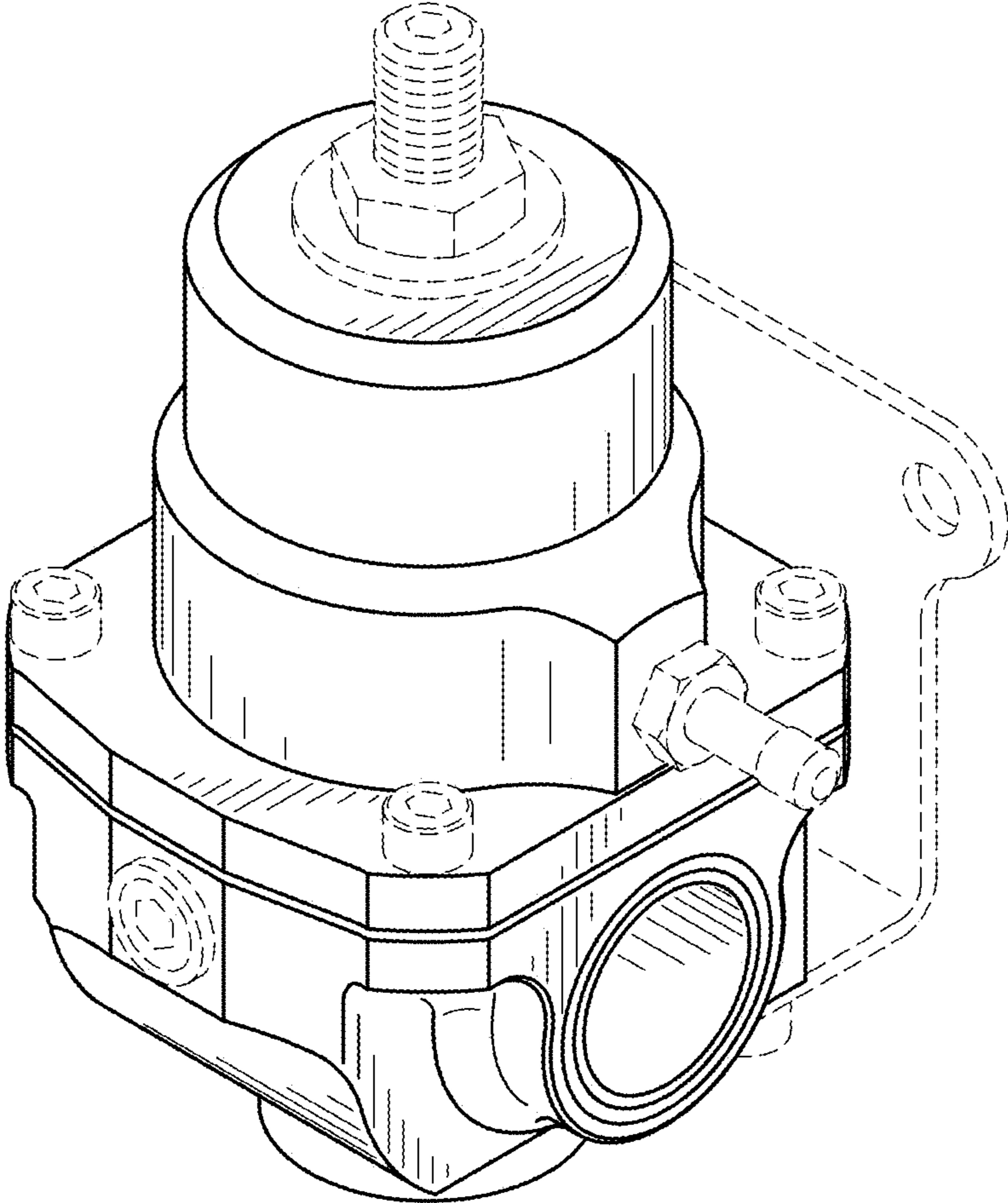
**DESCRIPTION**

FIG. 1 is a perspective view of a fuel pressure regulator showing my new design;  
FIG. 2 is a front elevational view thereof;  
FIG. 3 is a rear elevational view thereof;  
FIG. 4 is a left side elevational view thereof  
FIG. 5 is a right side elevational view thereof;  
FIG. 6 is a top plan view thereof; and,  
FIG. 7 is a bottom plan view thereof.  
The broken lines in the Figures are included for the purpose of illustrating portions of the fuel pressure regulator that form no part of the claimed design.

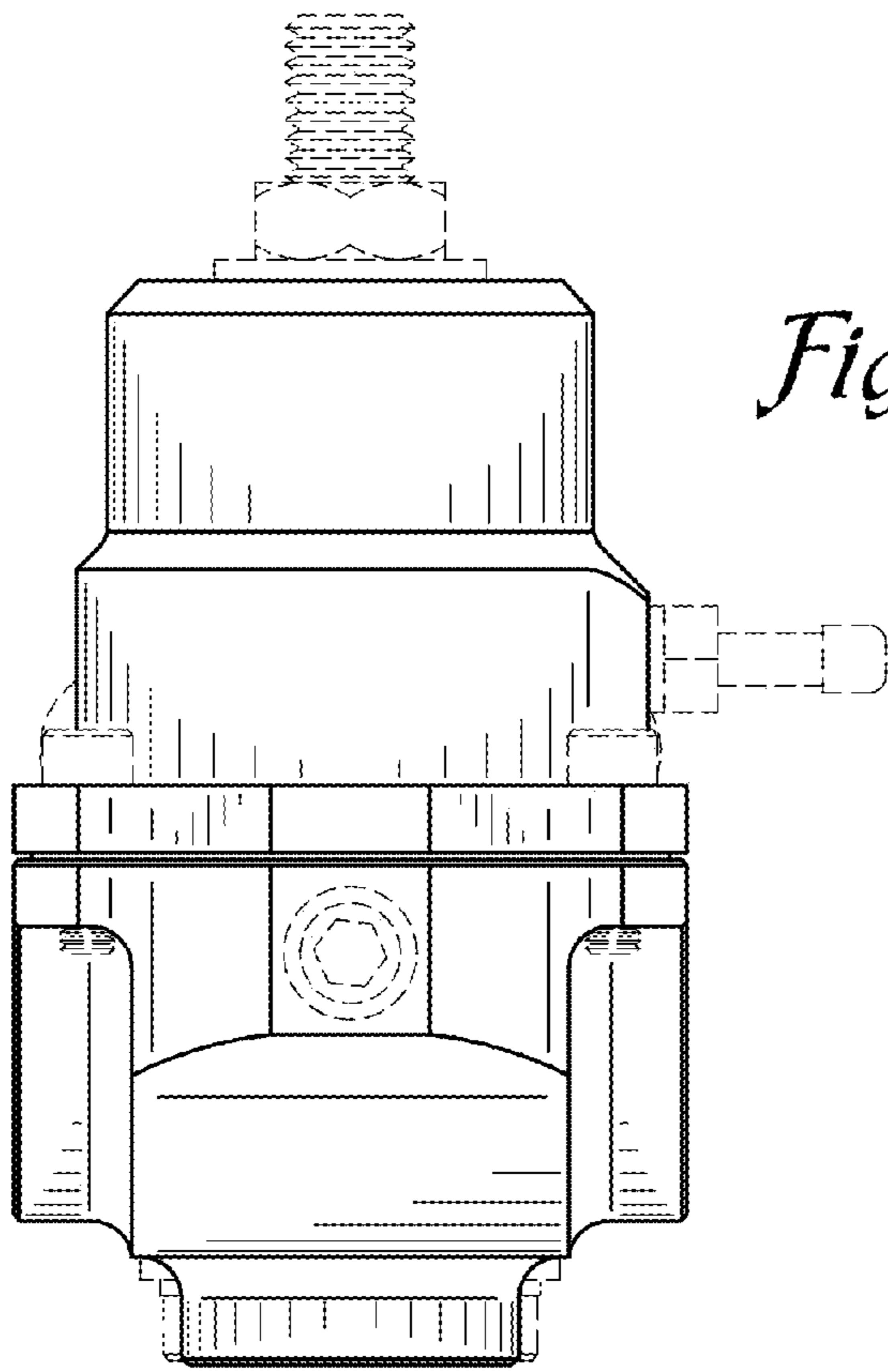
**1 Claim, 4 Drawing Sheets**

- (56) **References Cited**  
U.S. PATENT DOCUMENTS  
2,215,597 A \* 9/1940 Semon ..... G05D 16/0663  
137/505.42  
4,300,510 A 11/1981 Ishida et al.  
4,592,385 A 6/1986 Semon  
4,883,088 A 11/1989 Herbst  
5,076,320 A 12/1991 Robinson  
5,101,793 A 4/1992 Sample  
5,211,205 A 5/1993 Grant et al.

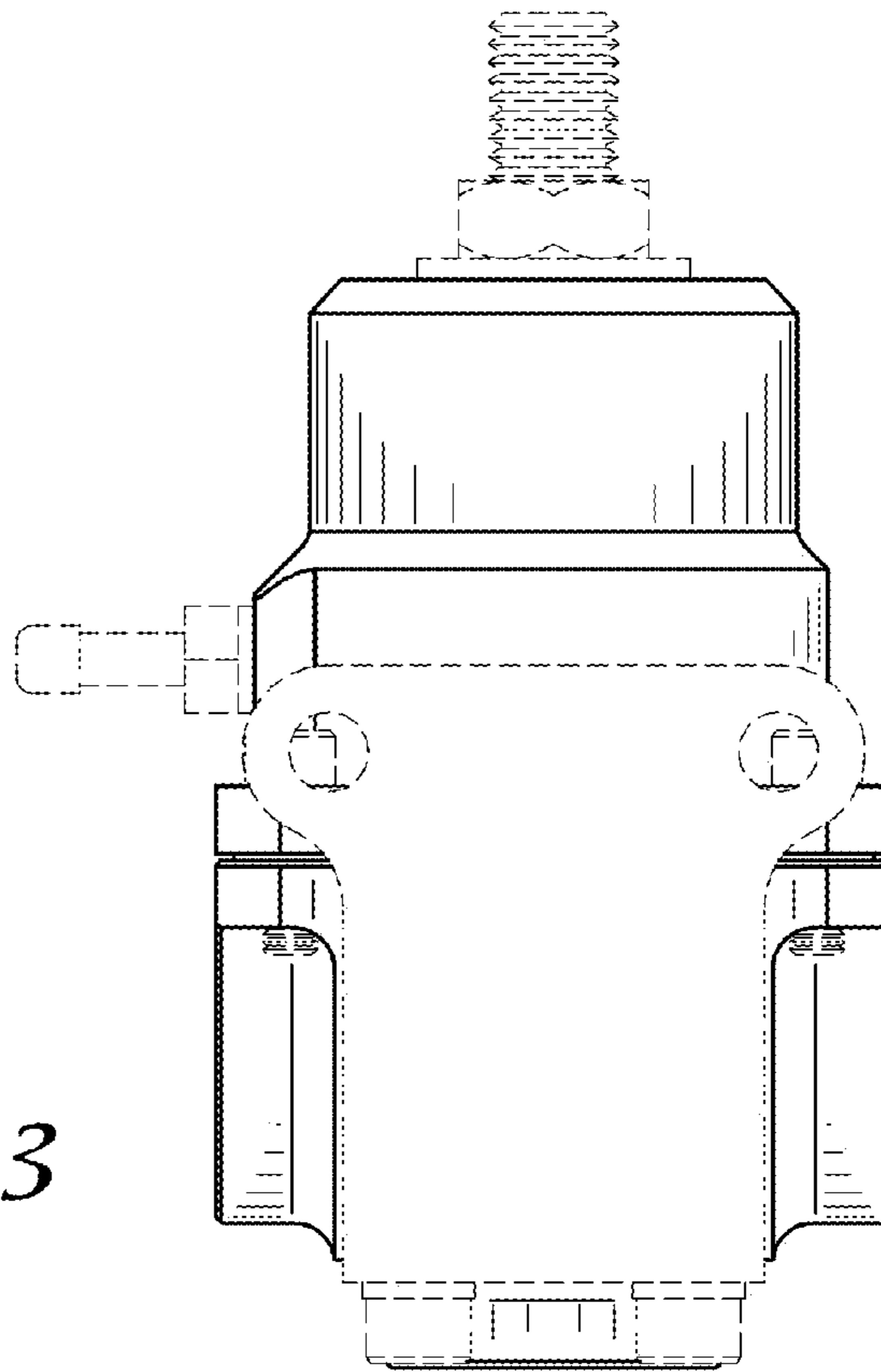




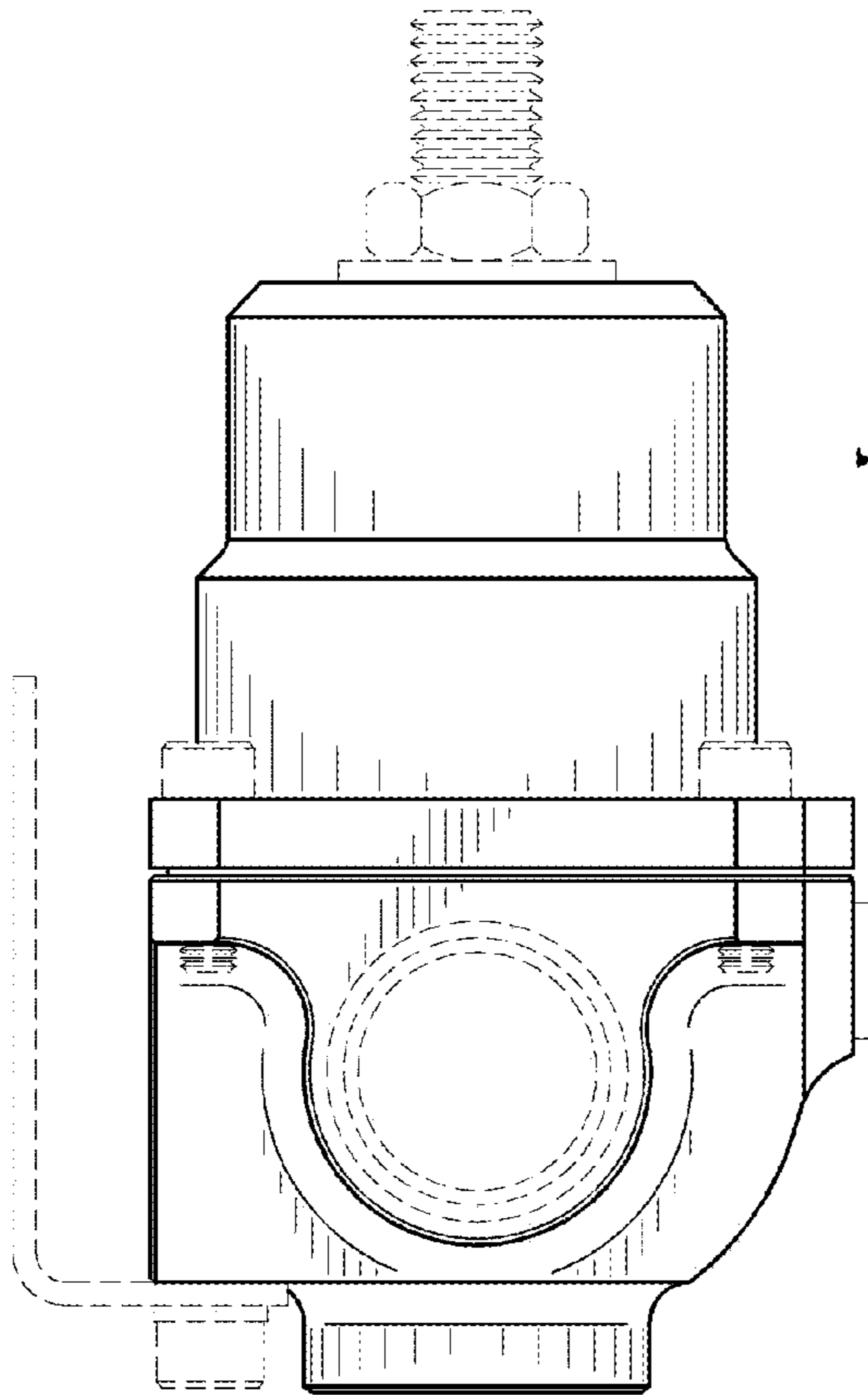
*Fig. 1*



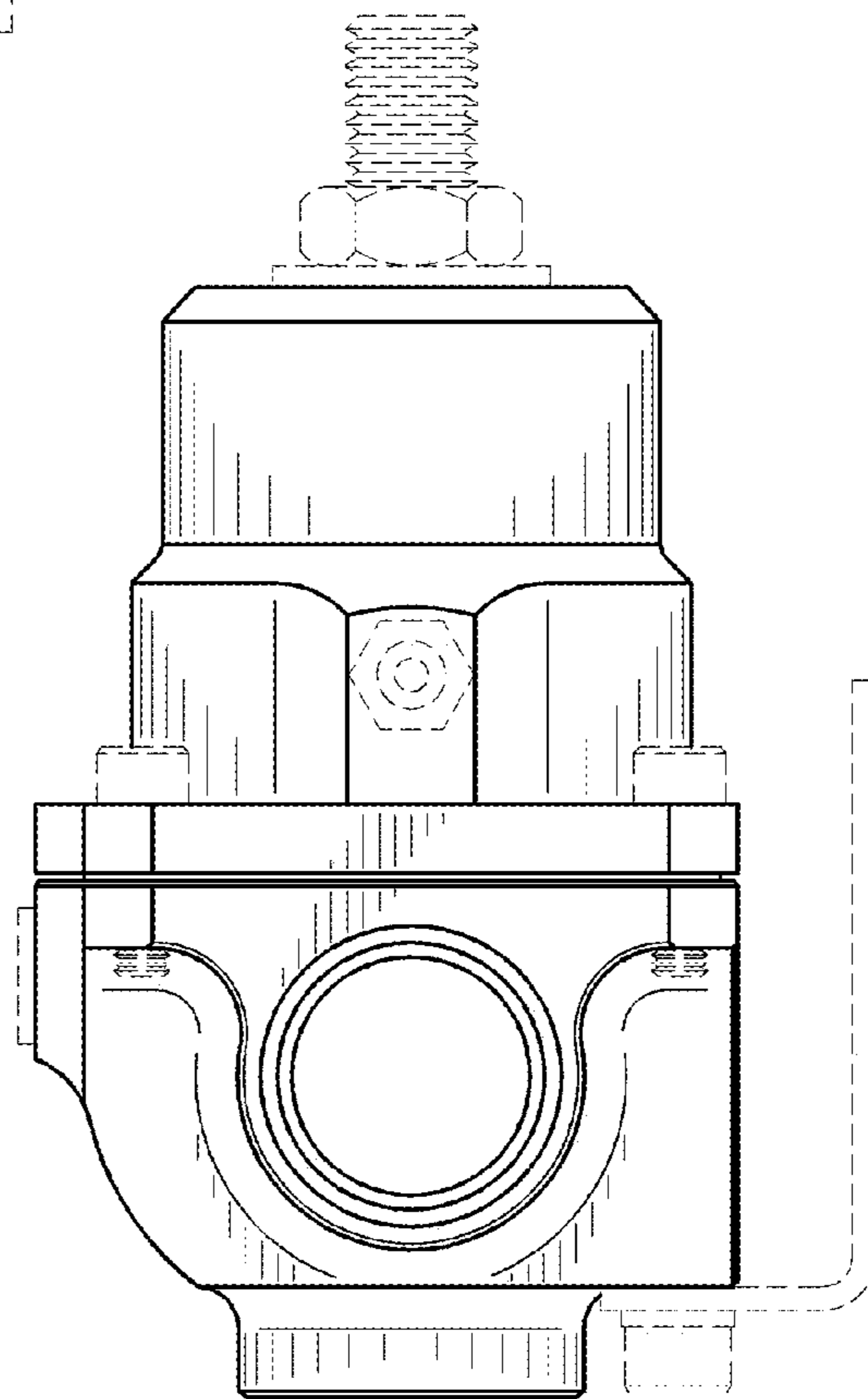
*Fig. 2*



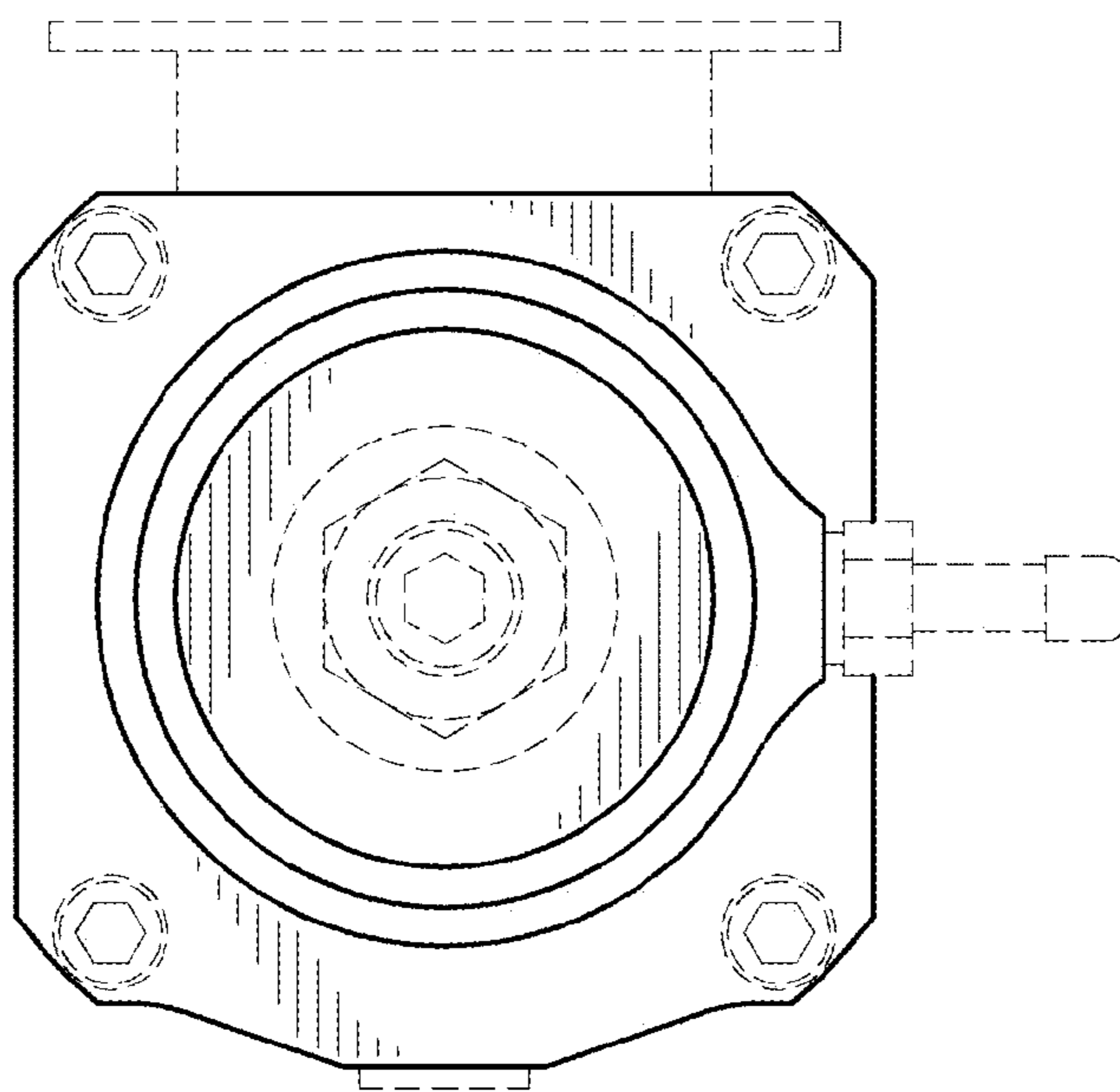
*Fig. 3*



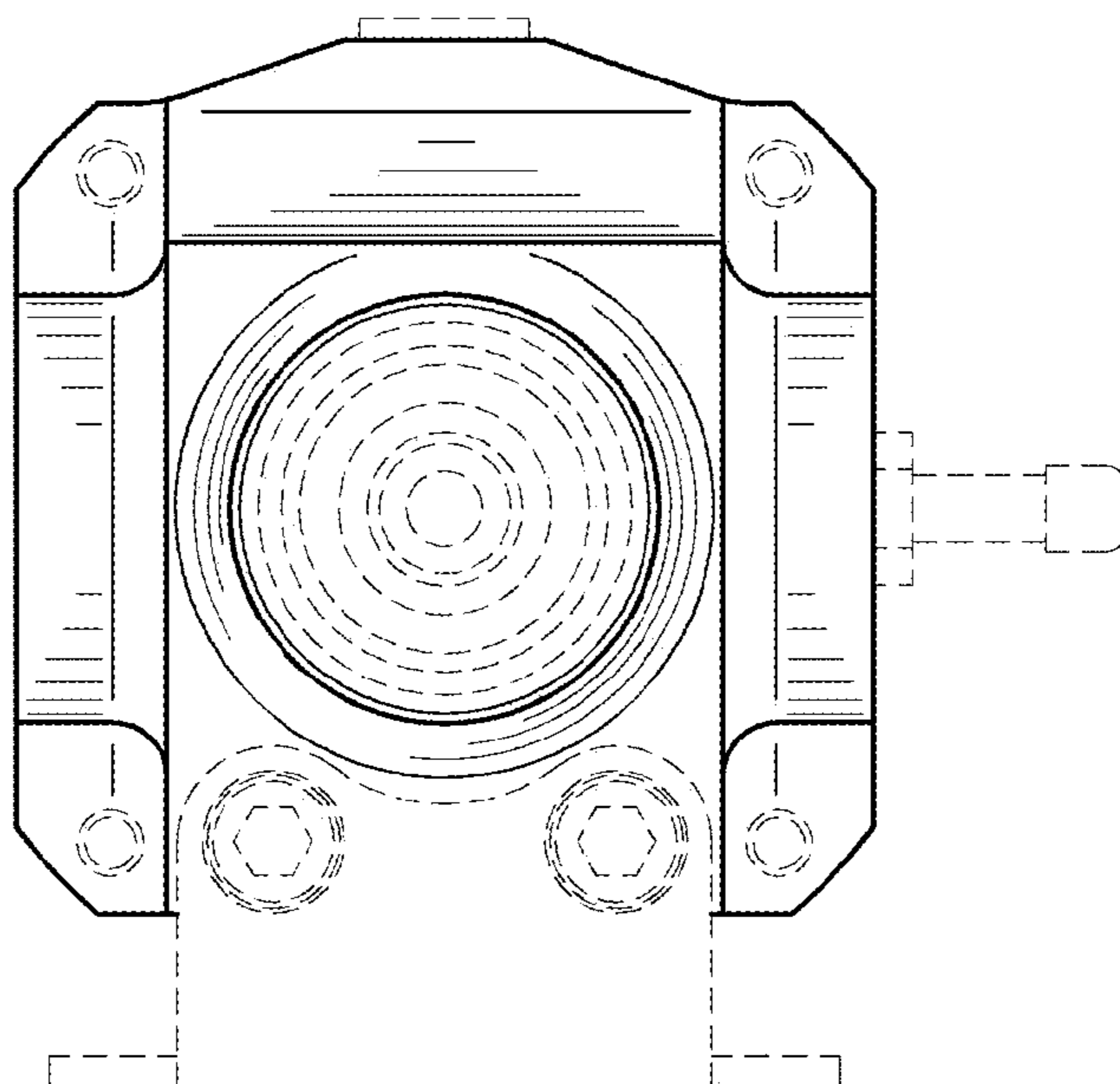
*Fig. 4*



*Fig. 5*



*Fig. 6*



*Fig. 7*