

US00D763195S

(12) **United States Design Patent**  
**Murphy et al.**

(10) **Patent No.:** **US D763,195 S**

(45) **Date of Patent:** **\*\* Aug. 9, 2016**

(54) **BUSBAR**

(71) Applicant: **General Electric Company**,  
Schenectady, NY (US)

(72) Inventors: **Mark Allen Murphy**, Erie, PA (US);  
**George Wnukoski**, Erie, PA (US);  
**Jeffrey John Wolff**, Lawrence Park, PA  
(US); **Lindsay Short**, Erie, PA (US)

(73) Assignee: **General Electric Company**,  
Schenectady, NY (US)

(\*\*) Term: **15 Years**

(21) Appl. No.: **29/542,934**

(22) Filed: **Oct. 19, 2015**

**Related U.S. Application Data**

(62) Division of application No. 29/509,696, filed on Nov.  
20, 2014, now Pat. No. Des. 743,912.

(51) **LOC (10) Cl.** ..... **13-03**

(52) **U.S. Cl.**  
USPC ..... **D13/147; D13/154**

(58) **Field of Classification Search**  
USPC ..... **D13/146, 147, 154, 184, 199**  
See application file for complete search history.

(56) **References Cited**

U.S. PATENT DOCUMENTS

D423,329 S \* 4/2000 Adams ..... D8/354

\* cited by examiner

*Primary Examiner* — Daniel Bui

(74) *Attorney, Agent, or Firm* — GE Global Patent Operation

(57) **CLAIM**

The ornamental design for a busbar, as shown and described.

**DESCRIPTION**

FIG. 1 is a top perspective view of a busbar showing our new design;

FIG. 2 is a top plan view thereof;

FIG. 3 is a bottom plan view thereof;

FIG. 4 is a rear view thereof;

FIG. 5 is a front view thereof;

FIG. 6 is a side view thereof;

FIG. 7 is an opposite side view thereof; and,

FIG. 8 is a bottom perspective view thereof.

The broken line portion of the figure drawings is included to show unclaimed subject matter only and forms no part of the claimed designs.

**1 Claim, 5 Drawing Sheets**

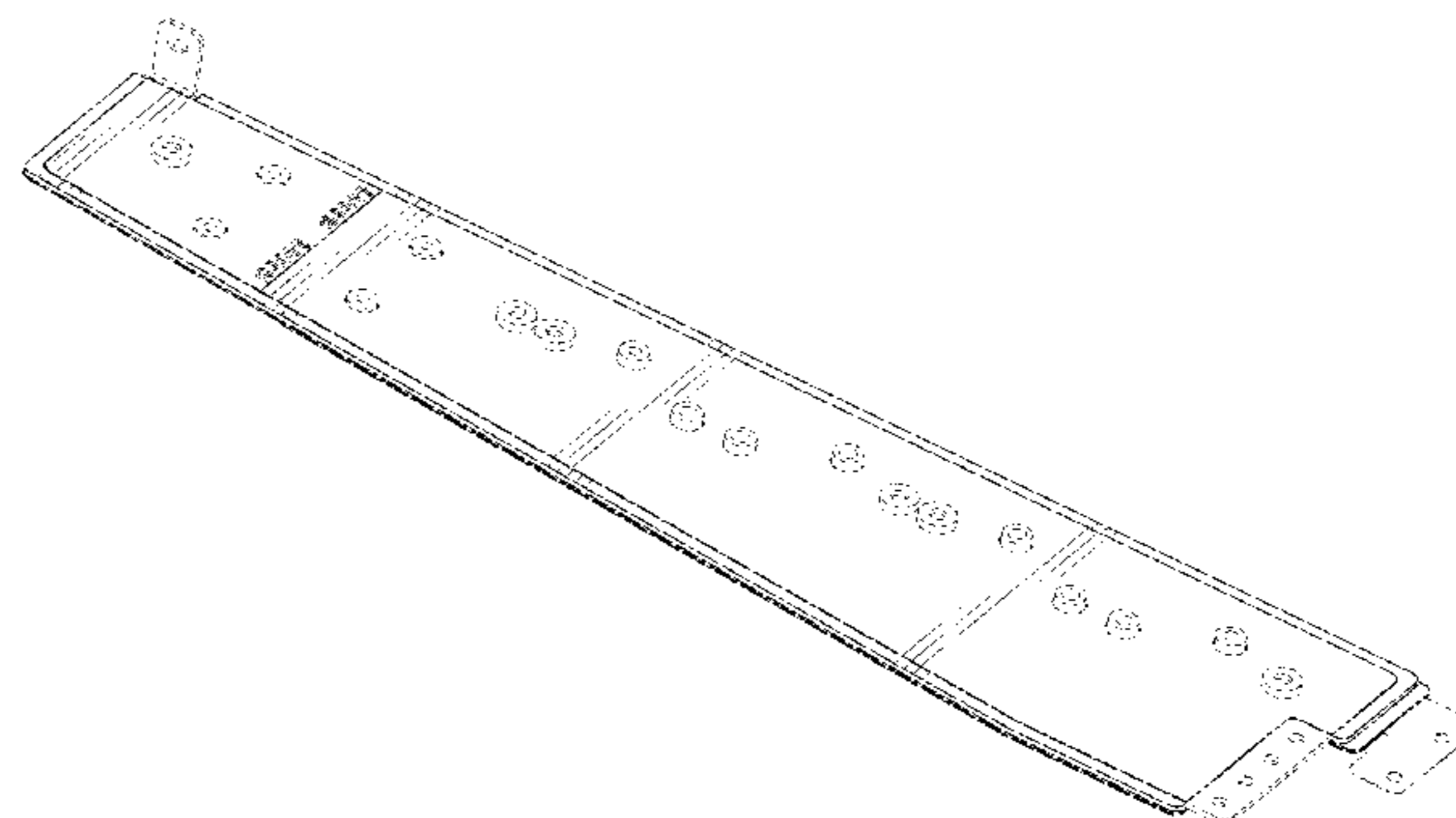
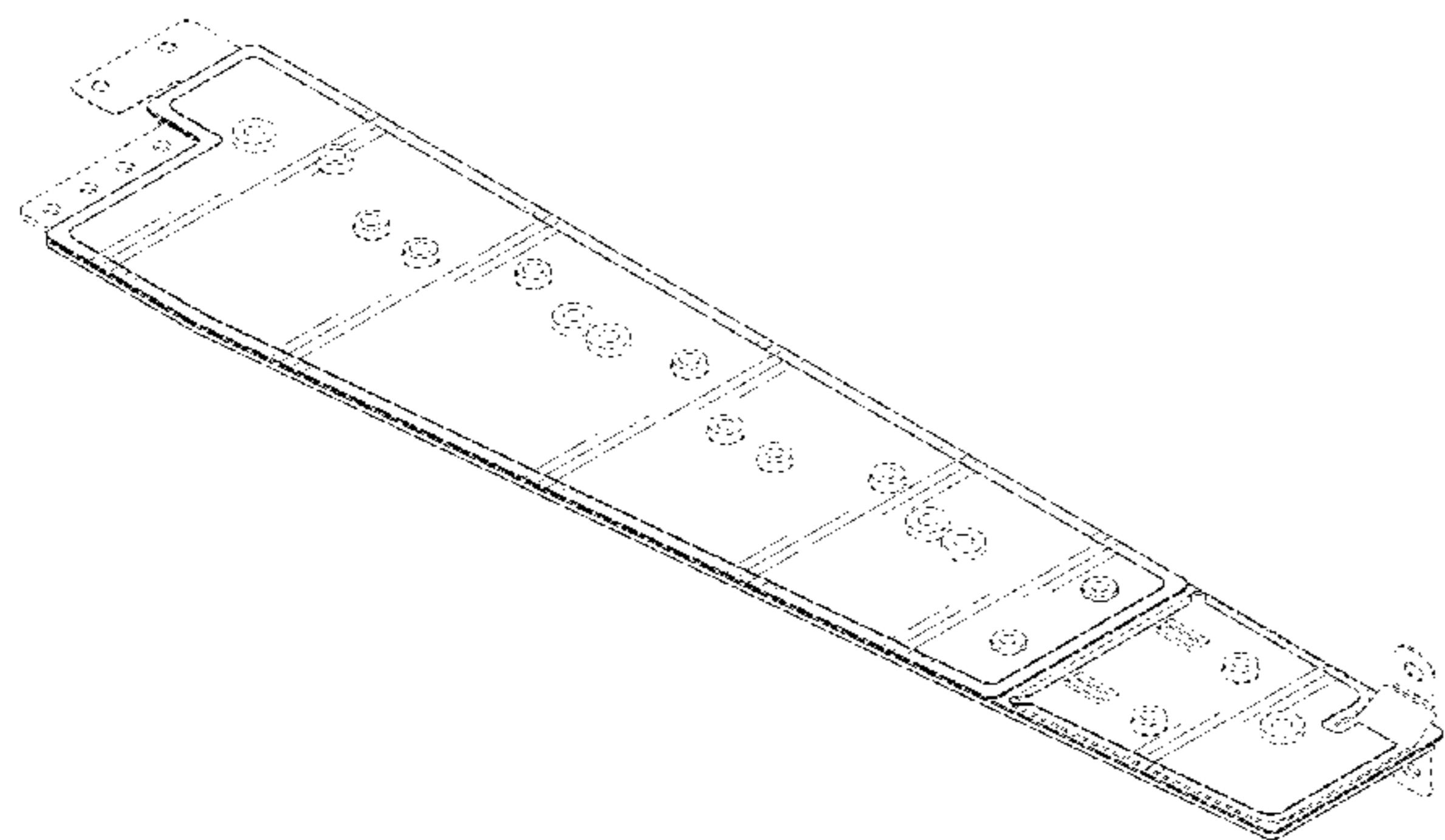

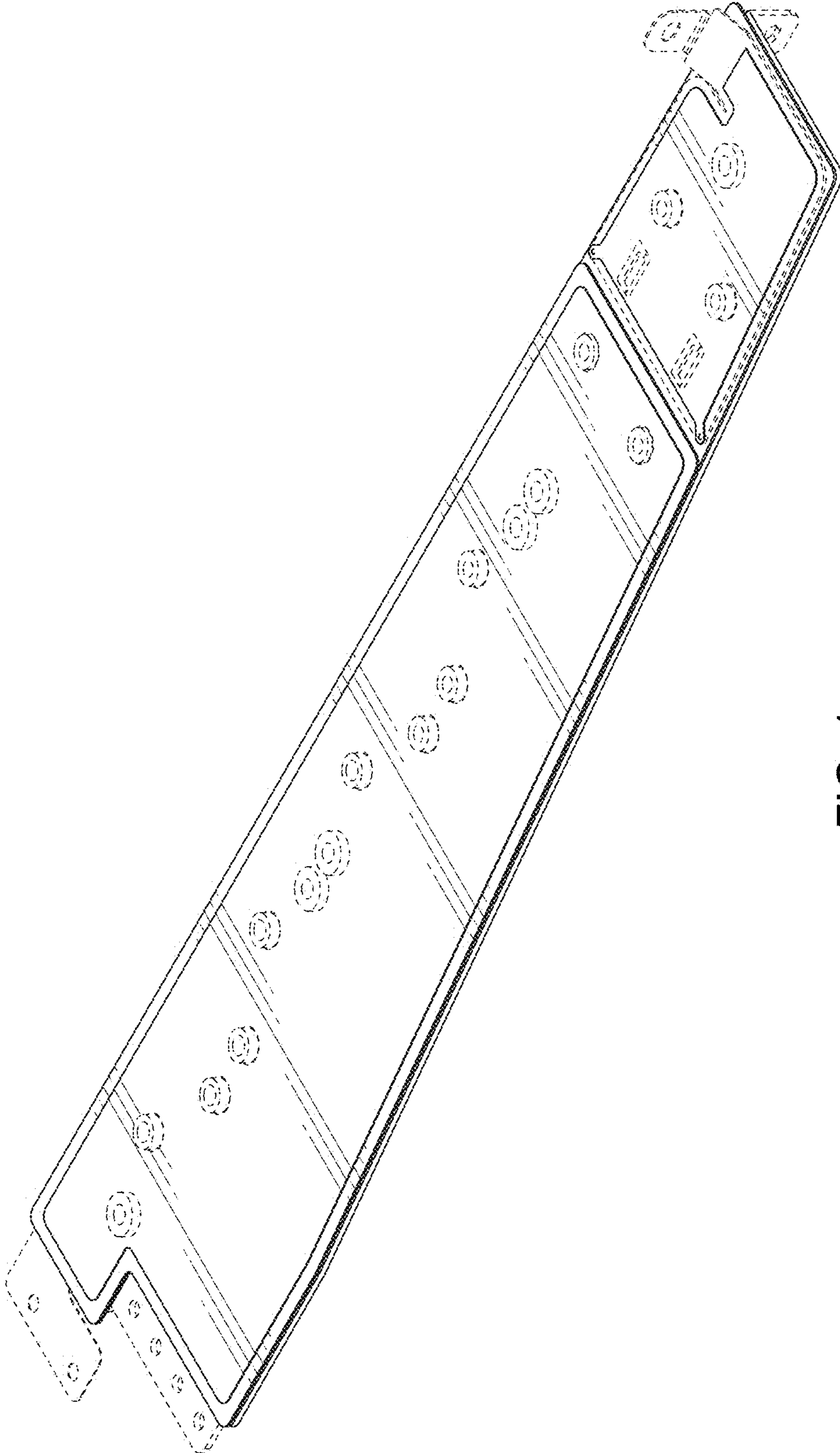

FIG. 1

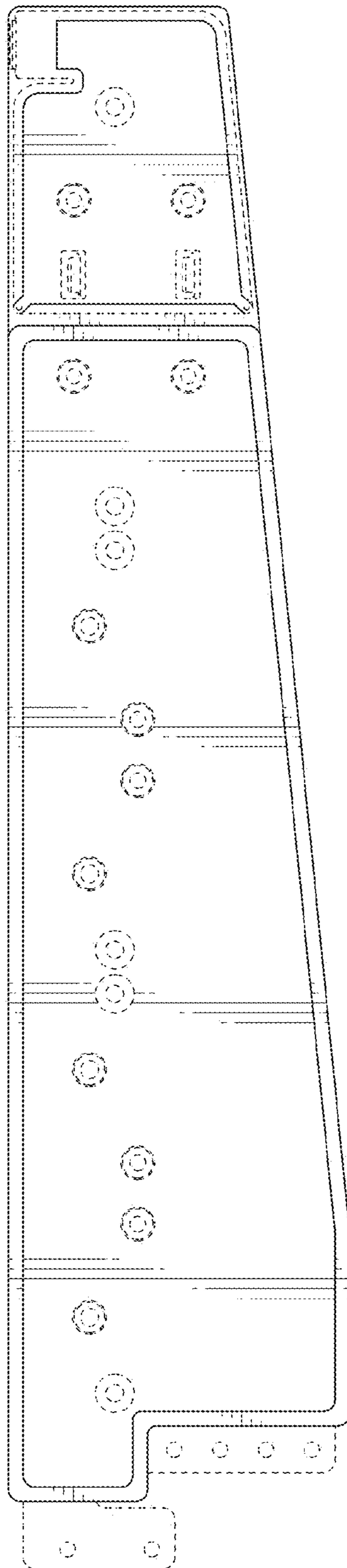

FIG. 2

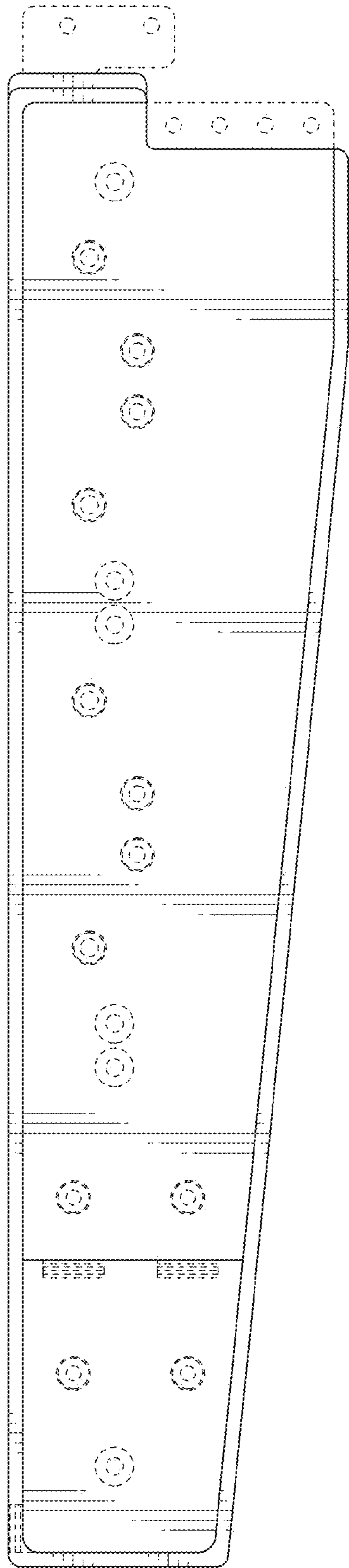

FIG. 3

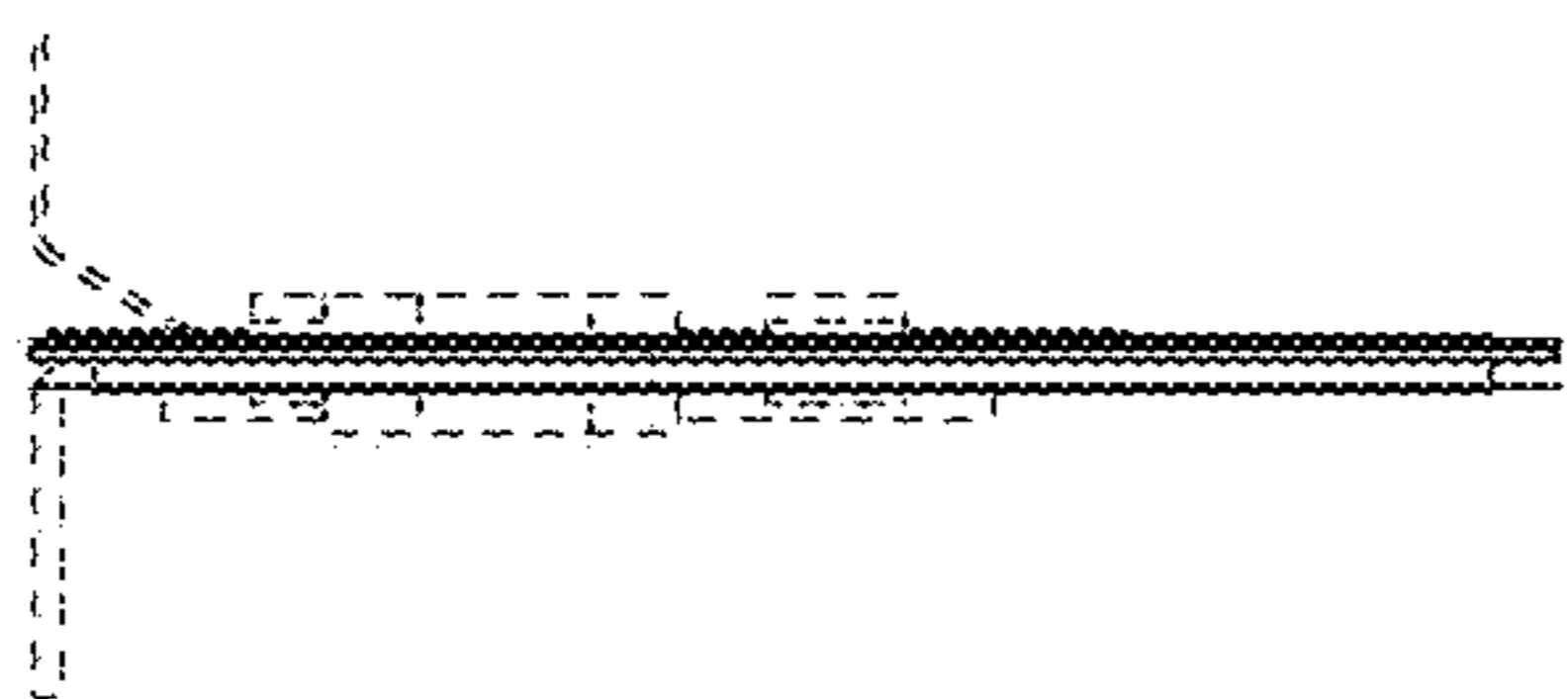

FIG. 4

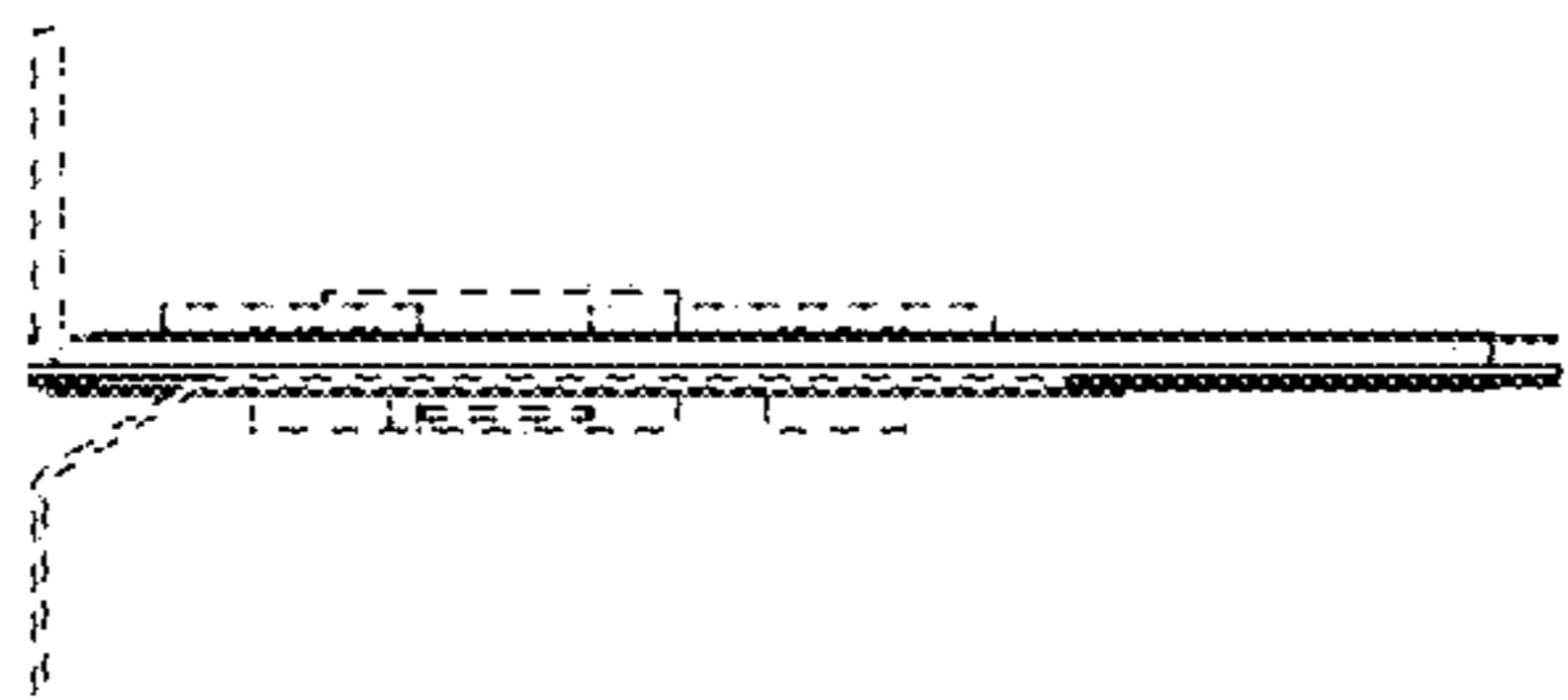

FIG. 5

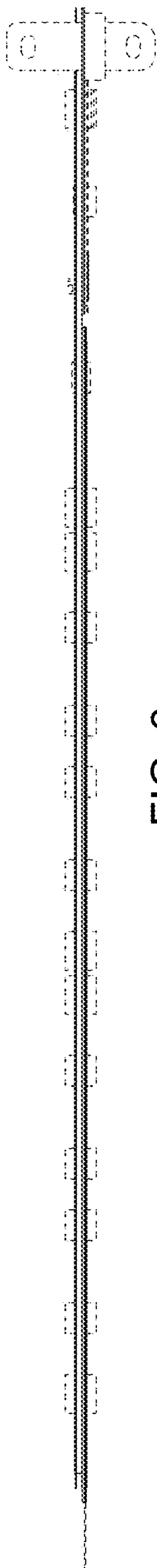

FIG. 6

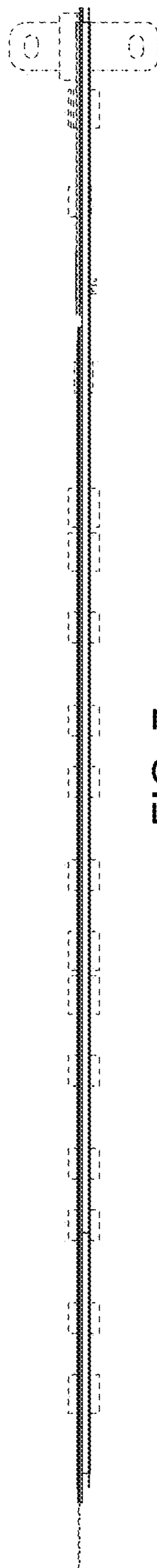

FIG. 7



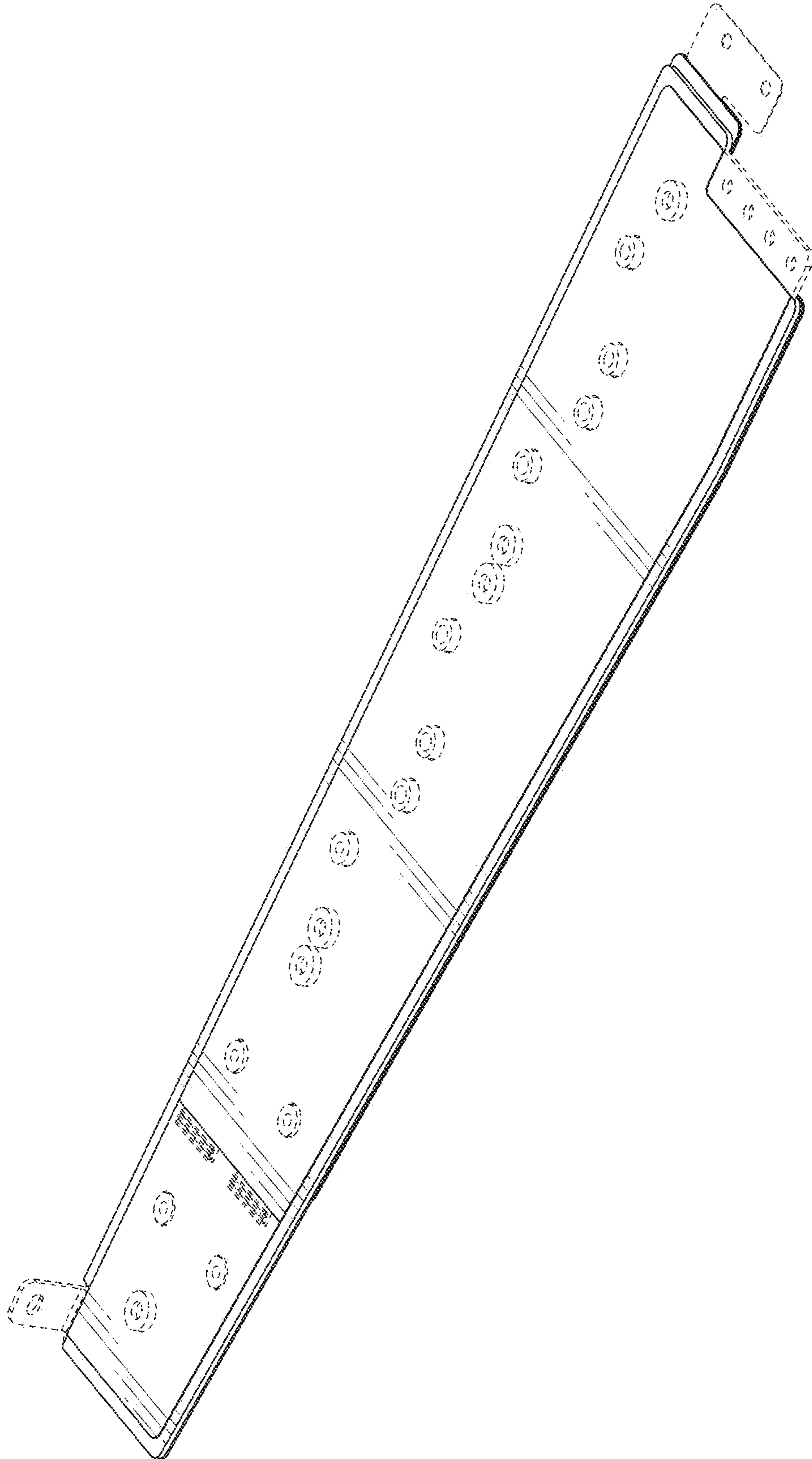

FIG. 8