



US00D763141S

(12) **United States Design Patent**  
**Lesnik et al.**

(10) **Patent No.:** **US D763,141 S**  
(45) **Date of Patent:** **\*\* Aug. 9, 2016**

(54) **REAR PORTION OF A VEHICLE, TOY,  
AND/OR REPLICAS THEREOF**

(71) Applicant: **Daimler AG**, Stuttgart (DE)

(72) Inventors: **Robert Lesnik**, Leonberg (DE); **Gorden  
Wagener**, Gaeufelden (DE)

(73) Assignee: **Daimler AG**, Stuttgart (DE)

(\*\*) Term: **14 Years**

(21) Appl. No.: **29/523,475**

(22) Filed: **Apr. 10, 2015**

(30) **Foreign Application Priority Data**

Oct. 13, 2014 (WO) ..... DM/084 656

(51) **LOC (10) Cl.** ..... **12-16**

(52) **U.S. Cl.**  
USPC ..... **D12/164**

(58) **Field of Classification Search**  
USPC ..... D12/86, 90-92, 164; D21/421, 433,  
D21/434; 296/181.1, 181.5  
CPC ..... B62D 35/00; B62D 25/00; B62D 25/06;  
B62D 25/08; B62D 33/00  
See application file for complete search history.

(56) **References Cited**

**U.S. PATENT DOCUMENTS**

D634,677 S \* 3/2011 Futschik ..... D12/164  
D635,893 S 4/2011 Baur et al.  
D664,482 S \* 7/2012 Futschik ..... D12/164  
D680,031 S \* 4/2013 Fetherston ..... D12/92  
D680,036 S \* 4/2013 Fetherston ..... D12/164

D688,162 S \* 8/2013 Fetherston ..... D12/92  
D688,174 S \* 8/2013 Fetherston ..... D12/164  
D702,156 S \* 4/2014 Futschik ..... D12/164  
D703,113 S \* 4/2014 Futschik ..... D12/164  
D711,791 S \* 8/2014 Futschik ..... D12/164  
D723,982 S \* 3/2015 Futschik ..... D12/164  
D733,620 S \* 7/2015 Fetherston ..... D12/164

\* cited by examiner

*Primary Examiner* — Melody N Brown

(74) *Attorney, Agent, or Firm* — Crowell & Moring LLP

(57) **CLAIM**

The ornamental design for a rear portion of a vehicle, toy,  
and/or replicas thereof, as shown and described.

**DESCRIPTION**

This application contains subject matter related to the follow-  
ing U.S. design patent applications:

Application Ser. No. 29/523,474, filed herewith and entitled  
“Vehicle, Toy, and/or Replicas Thereof”;

Application Ser. No. 29/523,476, filed herewith and entitled  
“Taillight for a Vehicle”;

Application Ser. No. 29/523,477, filed herewith and entitled  
“Taillight for a Vehicle”; and

Application Ser. No. 29/523,480, filed herewith and entitled  
“Vehicle, Toy, and/or Replicas Thereof”.

FIG. 1 is a left, front perspective view of a rear portion of a  
vehicle, toy, and/or replicas thereof according to the design;

FIG. 2 is a left side view thereof;

FIG. 3 is a right side view thereof;

FIG. 4 is a front view thereof; and,

FIG. 5 is a top view thereof.

The broken lines are for illustrative purposes only and form  
no part of the claimed design. The broken line which defines  
the bounds of the claimed design forms no part thereof.

**1 Claim, 5 Drawing Sheets**

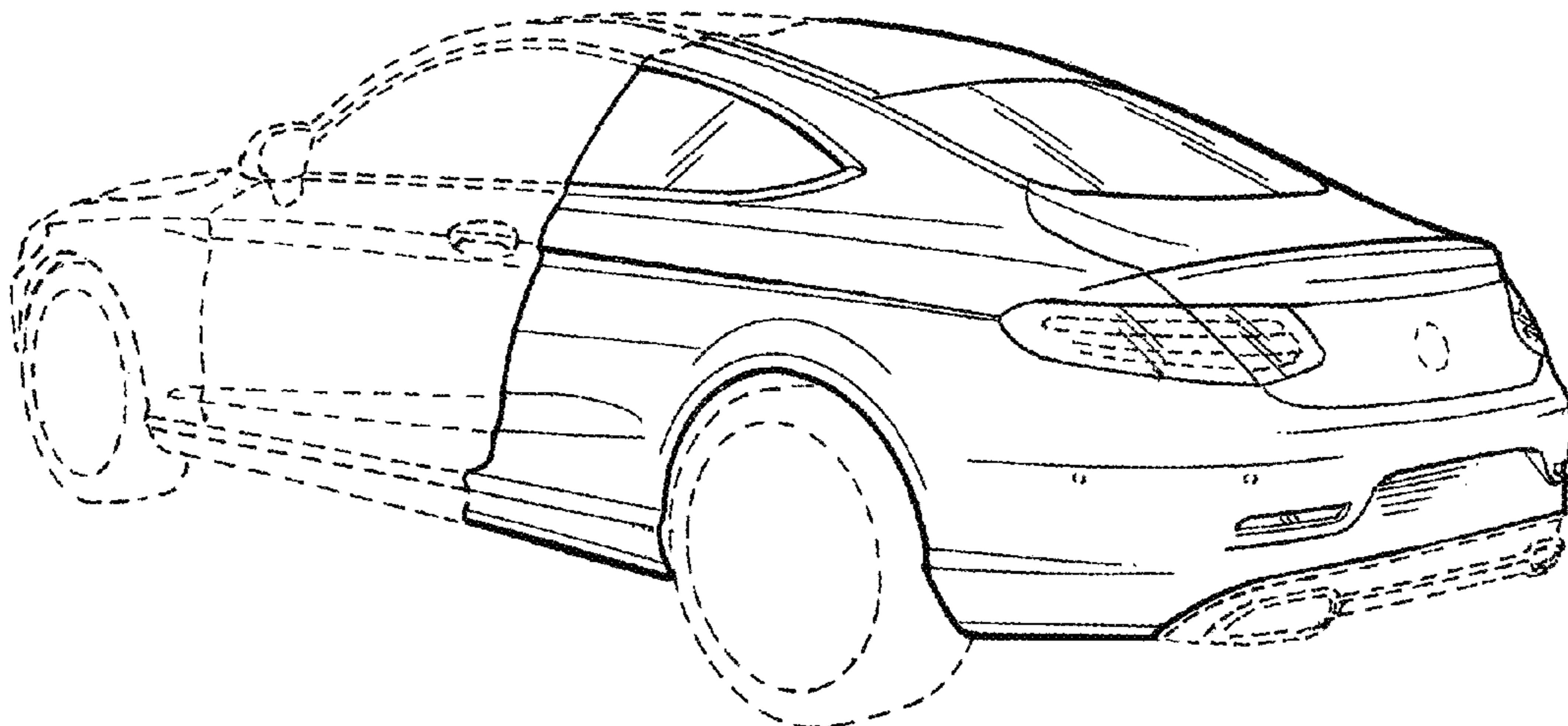

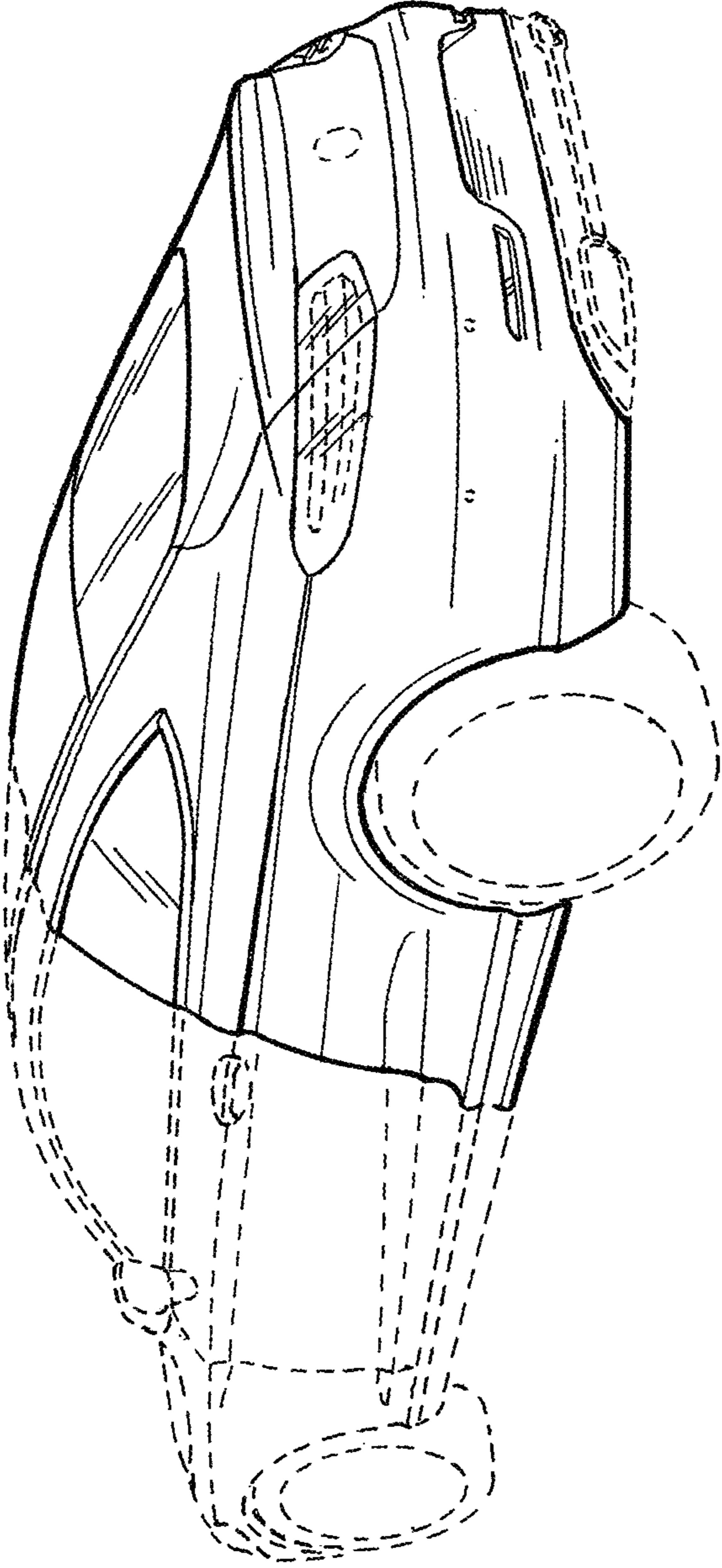

FIG. 1

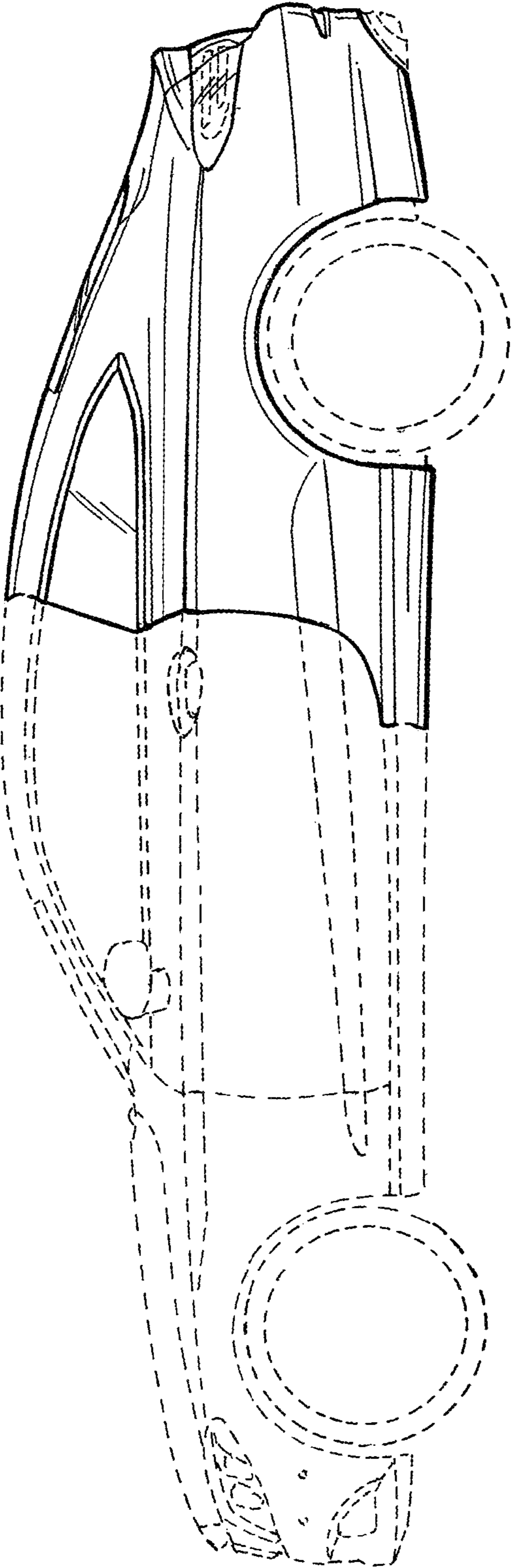

FIG. 2

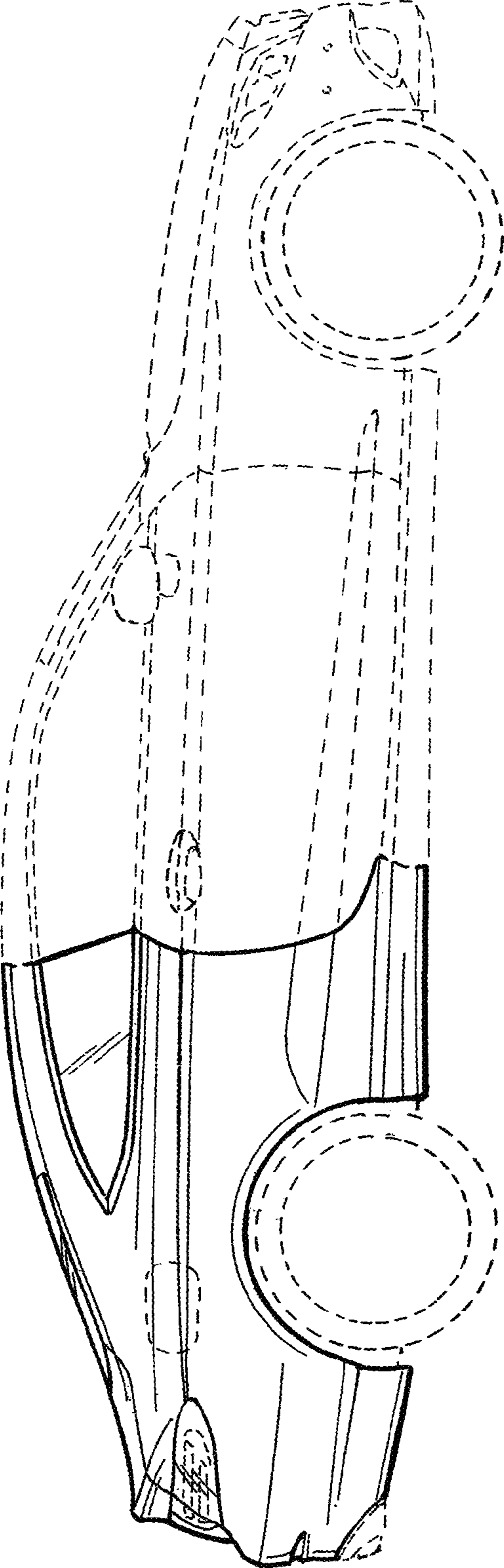

FIG. 3

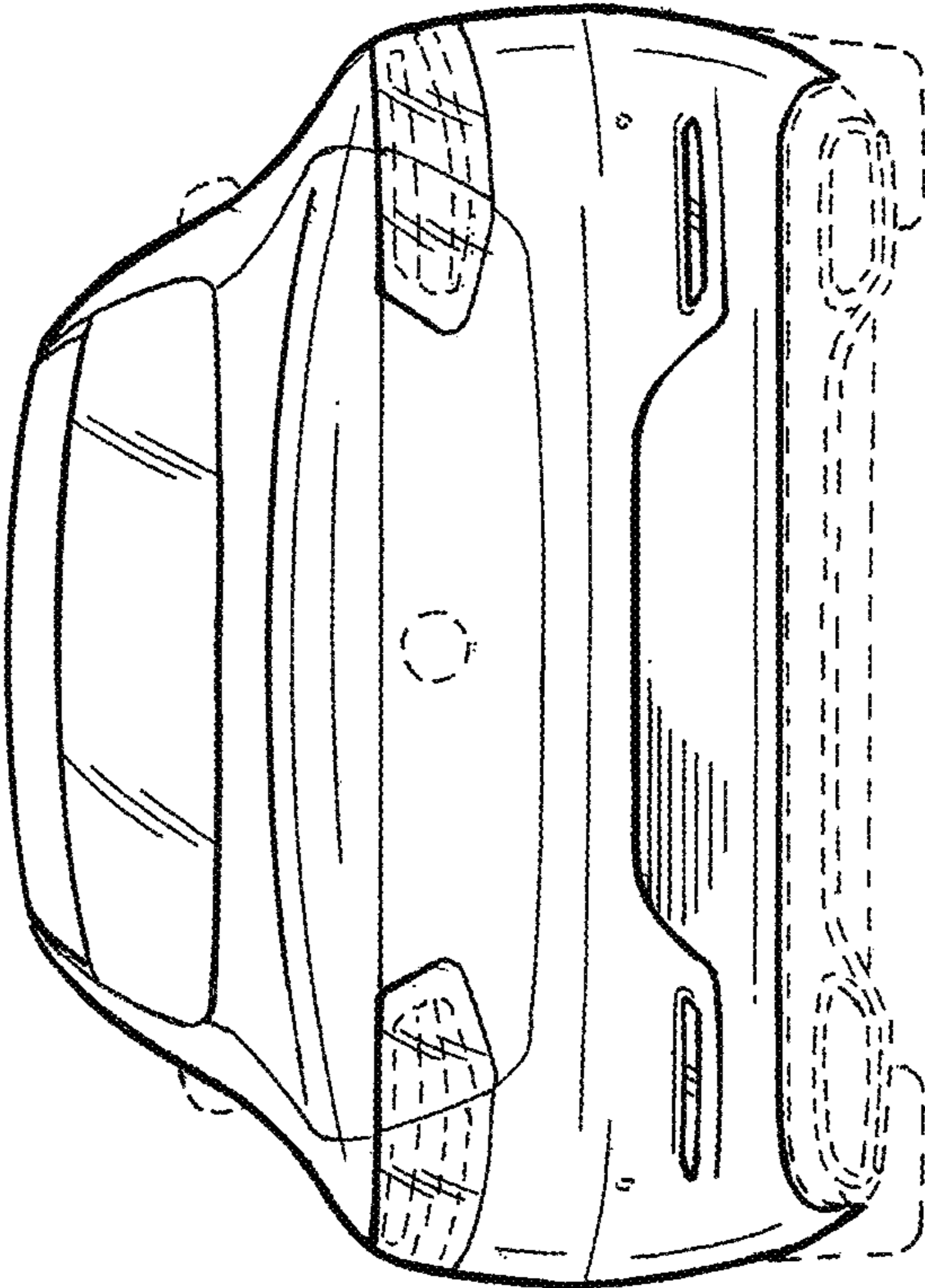

FIG. 4

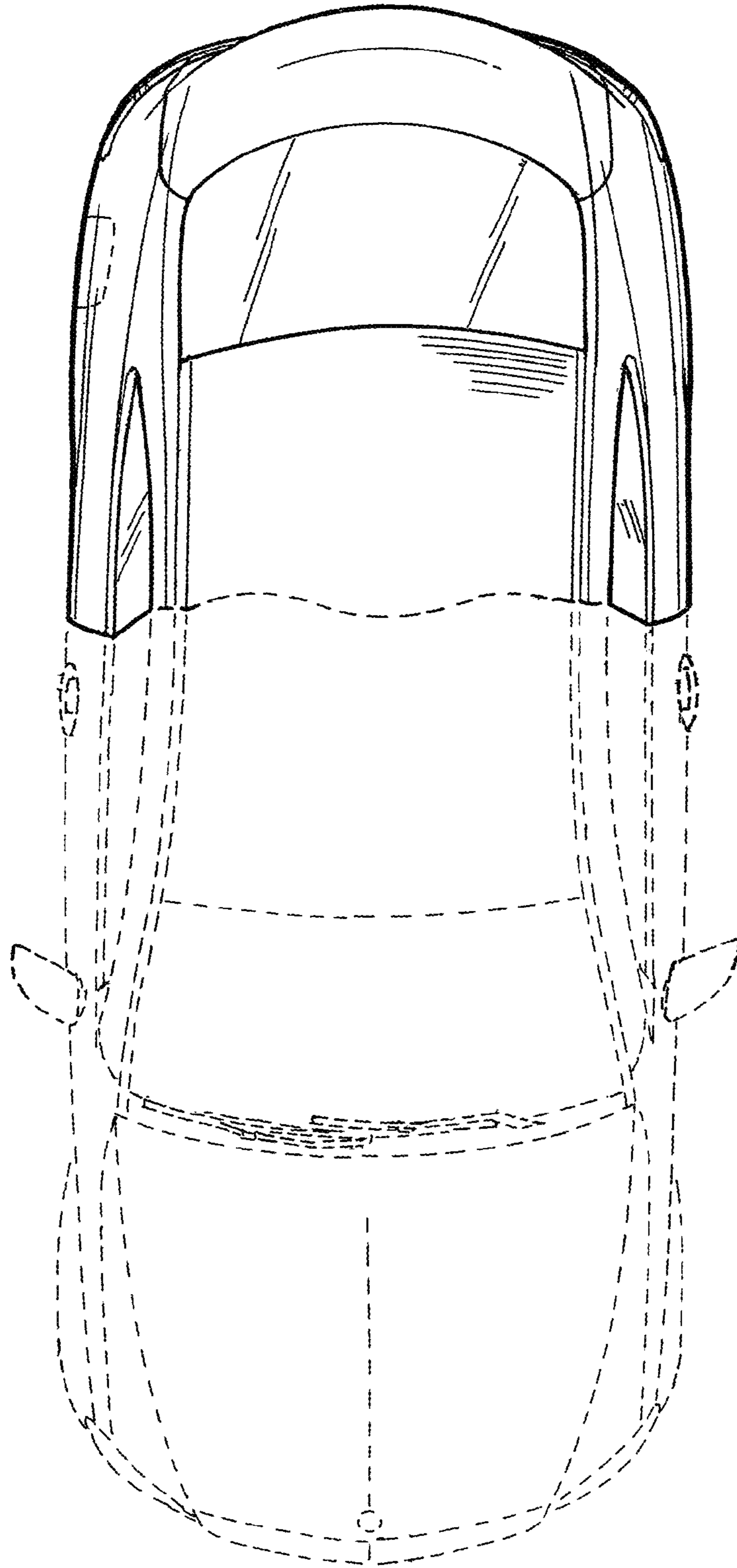

FIG. 5