

US00D763090S

(12) **United States Design Patent**
Zeng et al.

(10) **Patent No.:** **US D763,090 S**
(45) **Date of Patent:** **** Aug. 9, 2016**

(54) **BOTTLE**
(71) Applicant: **The Coca-Cola Company**, Atlanta, GA
(US)
(72) Inventors: **Wen Zeng**, Shanghai (CN); **Zhiheng Zhao**, Zhongshan (CN); **Simon Alan Daniel**, London (GB); **Robert Christopher Young**, London (GB); **Thomas Vaubourgeix**, London (GB)

D501,404 S 2/2005 Dalton et al.
D505,864 S 6/2005 Snyder
D508,854 S * 8/2005 Livingston D9/516
7,077,279 B2 * 7/2006 Melrose B65D 1/0223
215/381
7,347,339 B2 * 3/2008 Bangi B65D 1/0223
215/381
D585,293 S 1/2009 Honkawa
D611,828 S 3/2010 Lepoitevin
D613,166 S * 4/2010 Bentley D9/502
D623,529 S 9/2010 Yourist et al.
D624,427 S 9/2010 Yourist et al.
D626,851 S * 11/2010 El Aquah D9/520

(73) Assignee: **The Coca-Cola Company**, Atlanta, GA
(US)

(Continued)

(**) Term: **14 Years**

Primary Examiner — Catherine Tuttle

(74) *Attorney, Agent, or Firm* — Cynthia R. Parks; Parks IP Law LLC

(21) Appl. No.: **29/506,286**

(22) Filed: **Oct. 14, 2014**

(51) **LOC (10) Cl.** **09-01**

(52) **U.S. Cl.**
USPC **D9/538; D9/553; D9/557**

(58) **Field of Classification Search**
USPC D9/500–505, 516, 520, 521, 537–543,
D9/549–558, 435, 436
CPC B65D 1/02; B65D 1/0207; B65D 1/0223;
B65D 1/0261; B65D 1/0284; B65D 1/40;
B65D 1/44; B65D 2501/0018; B65D
2501/0027; B65D 2501/0036; B65D
2501/0045

See application file for complete search history.

(56) **References Cited**

U.S. PATENT DOCUMENTS

D409,091 S 5/1999 Beaver et al.
D420,594 S 2/2000 Weinstein et al.
6,213,326 B1 * 4/2001 Denner B65D 1/0223
215/383
D453,003 S * 1/2002 Rashid D9/502
D455,351 S 4/2002 Bailey
D461,417 S * 8/2002 Jerome D9/537
D496,264 S 9/2004 Eaton et al.
D497,549 S 10/2004 Andrews et al.
D500,447 S 1/2005 Snyder

(57) **CLAIM**

We claim the ornamental design for a bottle, as shown and described.

DESCRIPTION

FIG. 1 is a perspective view of one embodiment of a bottle in accordance with our new design;
FIG. 2 is a right view thereof;
FIG. 3 is a left view thereof;
FIG. 4 is a front view thereof;
FIG. 5 is a back view thereof;
FIG. 6 is a top view thereof;
FIG. 7 is a bottom view thereof;
FIG. 8 is a perspective view of another embodiment of a bottle in accordance with our new design;
FIG. 9 is a right view thereof;
FIG. 10 is a left view thereof;
FIG. 11 is a front view thereof;
FIG. 12 is a back view thereof;
FIG. 13 is a top view thereof; and,
FIG. 14 is a bottom view thereof.

The uneven-length broken lines represent unclaimed boundaries of the claimed design. The even-length broken lines showing the remainder of the bottle are for environmental purposes only and form no part of the claimed design.

1 Claim, 8 Drawing Sheets

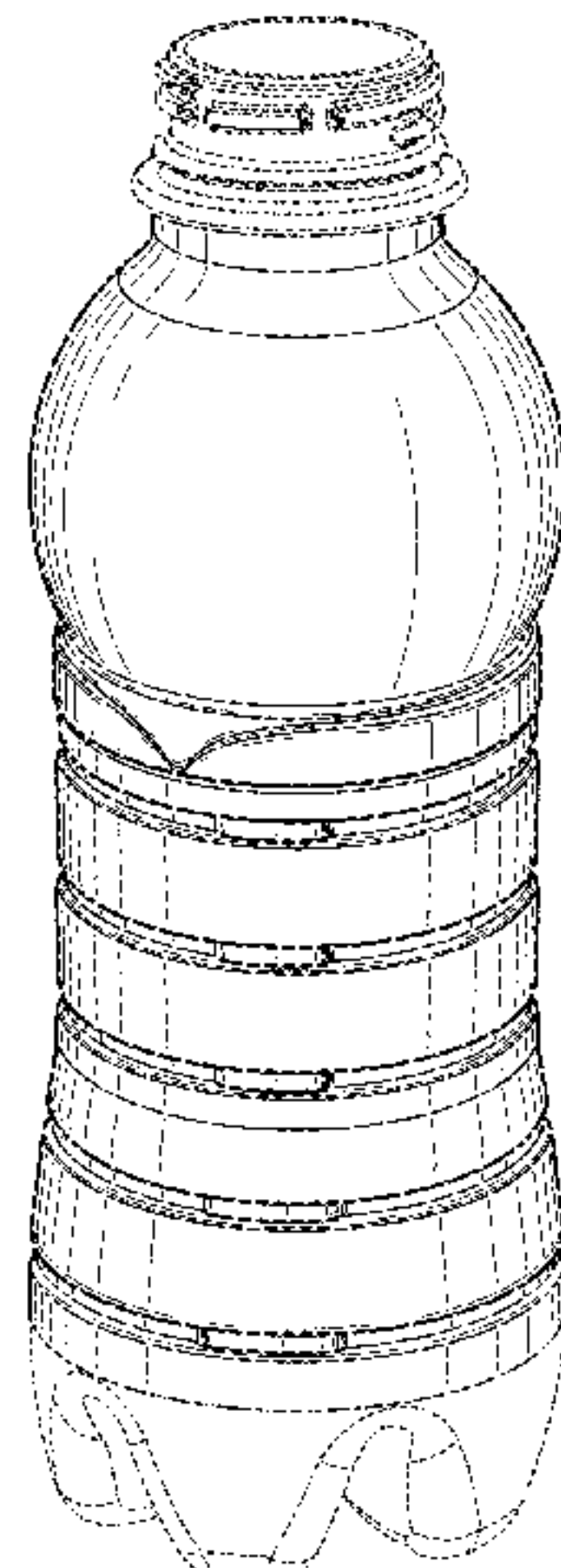

(56)

References Cited

U.S. PATENT DOCUMENTS

7,891,513 B2 *	2/2011	Mody	B29C 49/48	215/373	8,870,006 B2 *	10/2014	Kamineni	B65D 1/0223	215/381
D658,061 S	4/2012	Furlan			2001/0009244 A1 *	7/2001	Cheng	B65D 1/0284	215/375
8,567,625 B2 *	10/2013	Nemoto	B65D 1/0223	215/384	2013/0153529 A1 *	6/2013	Nakayama	B65D 23/001	215/370

* cited by examiner

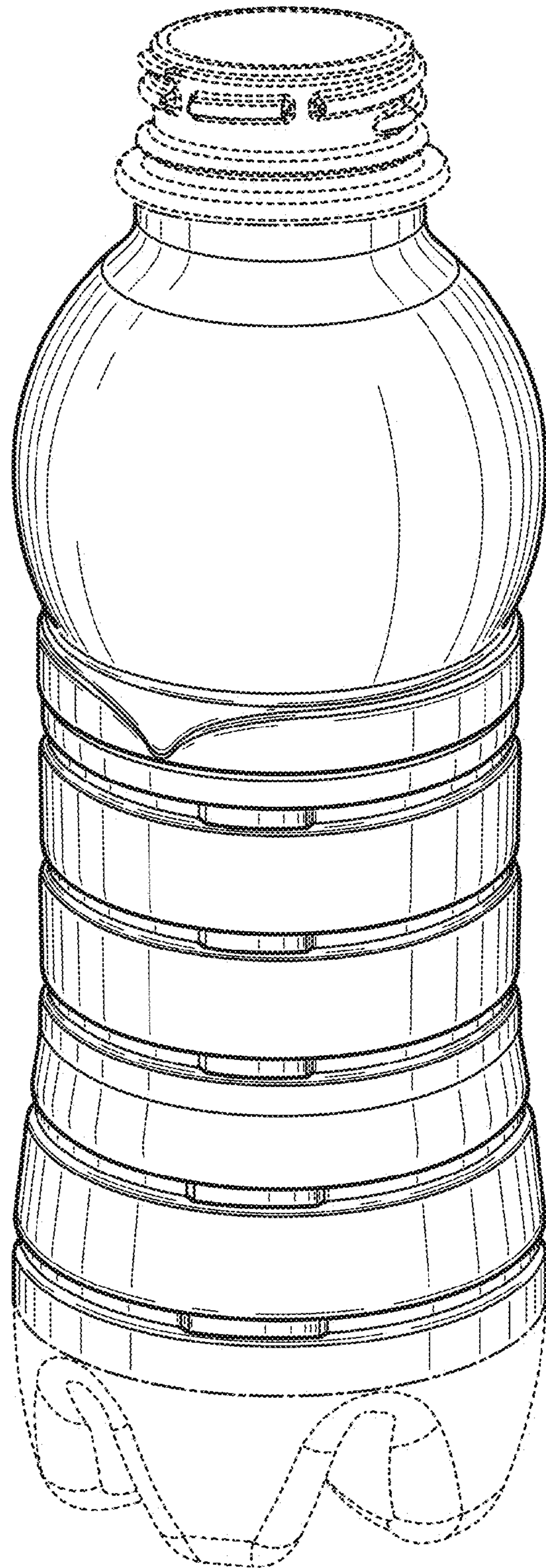

FIG. 1

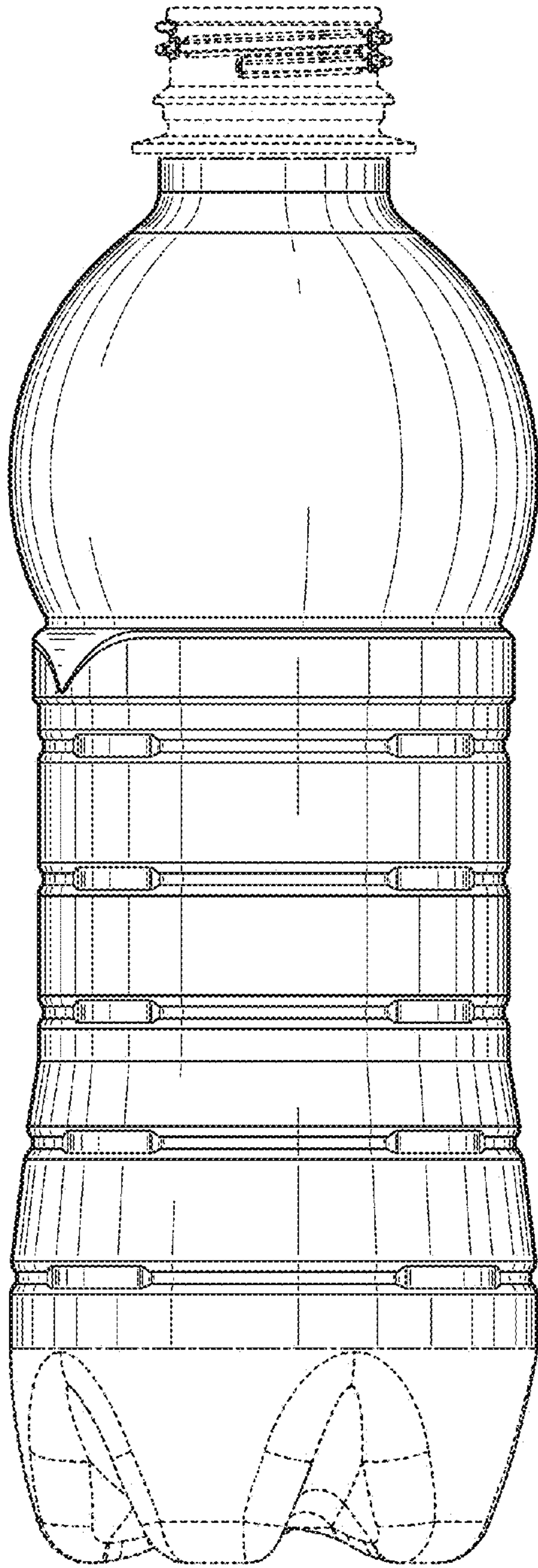

FIG. 2

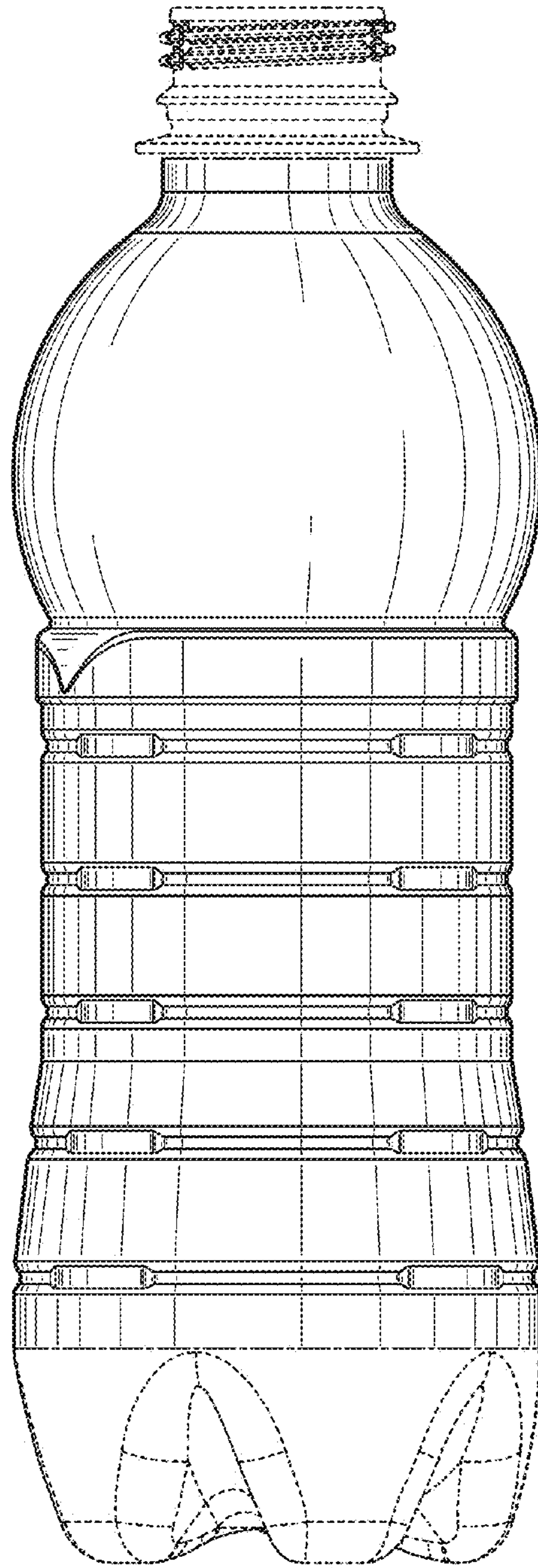

FIG. 3

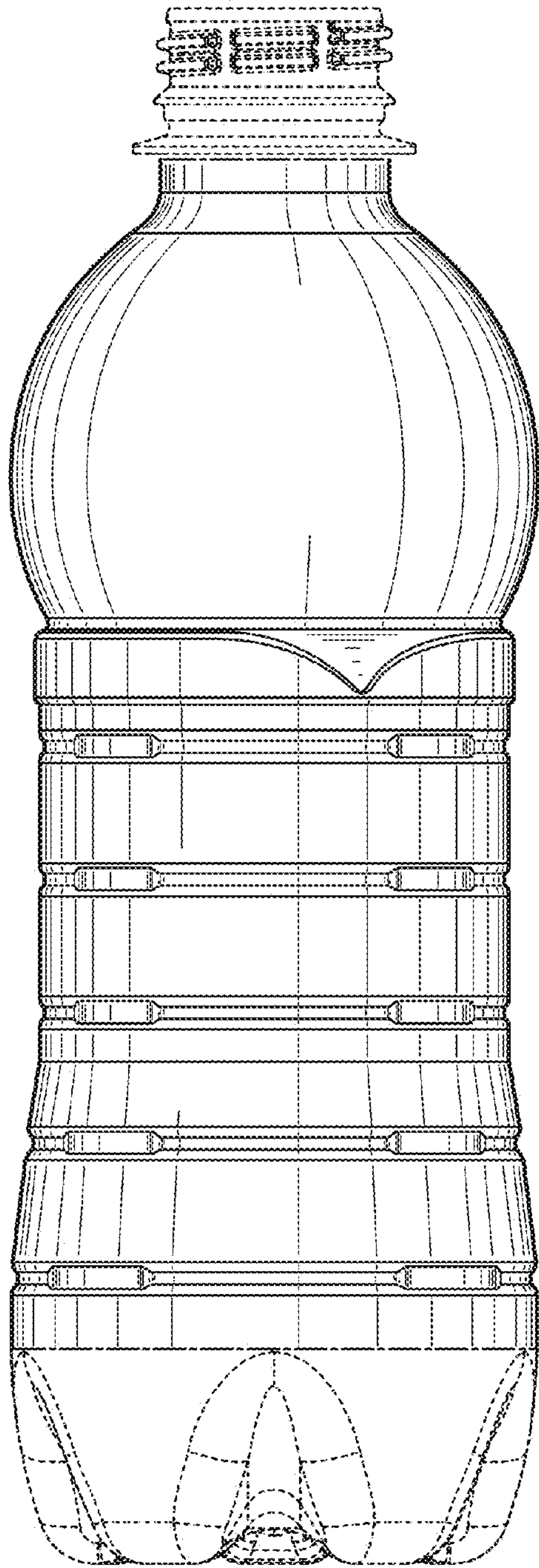

FIG. 4

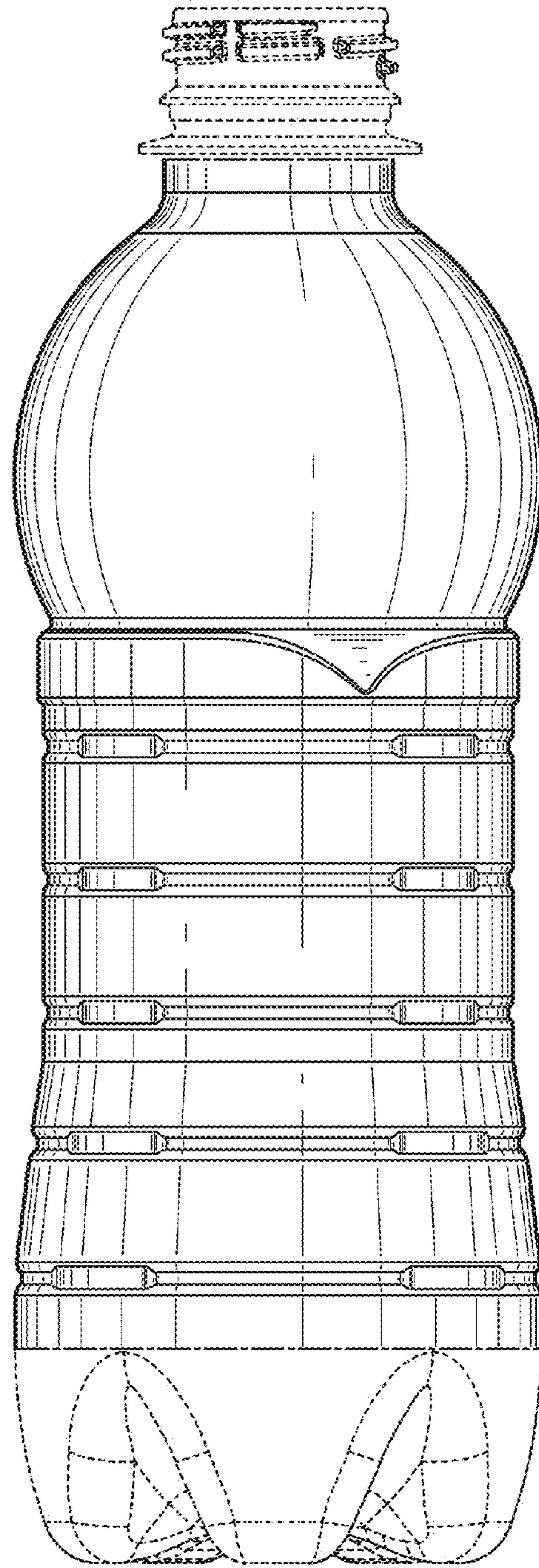

FIG. 5

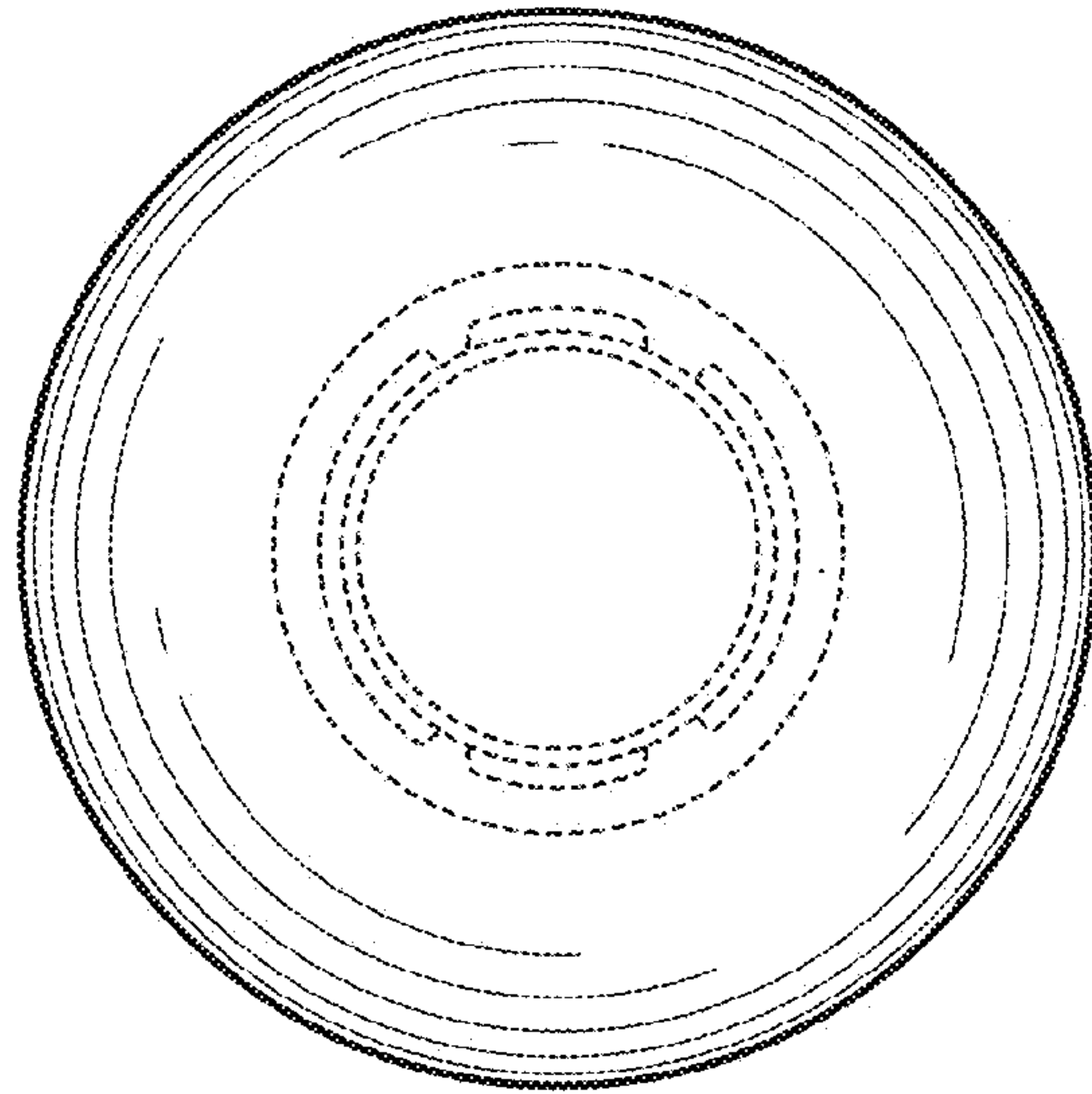

FIG. 6

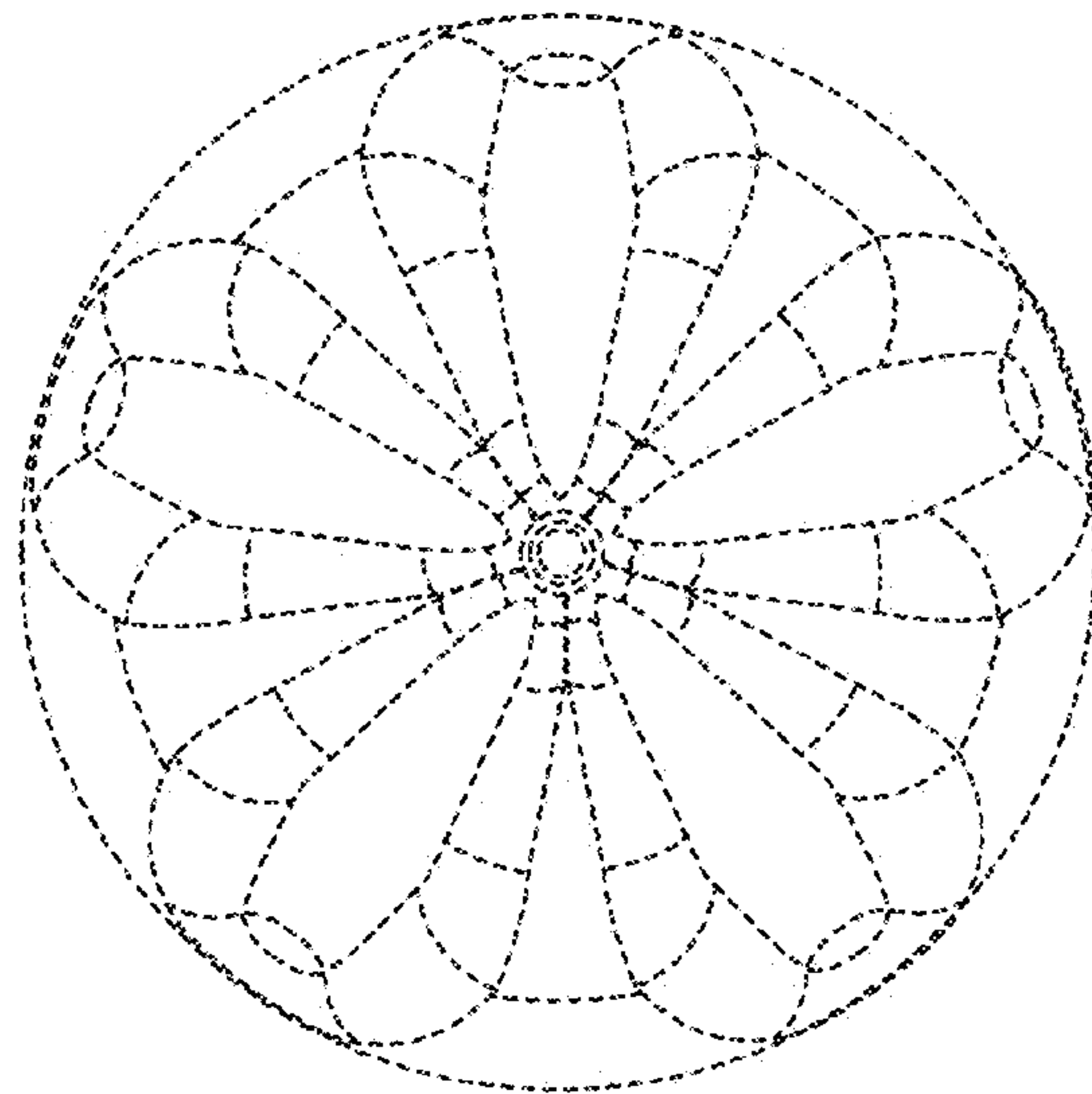

FIG. 7

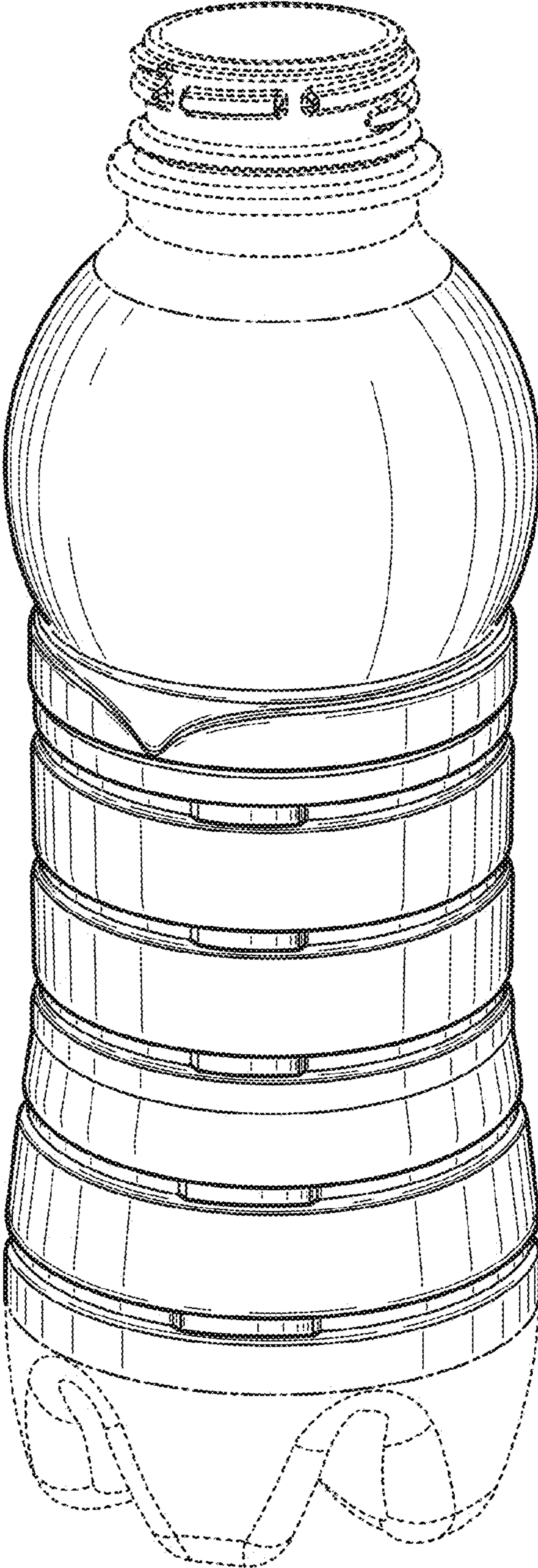

FIG. 8

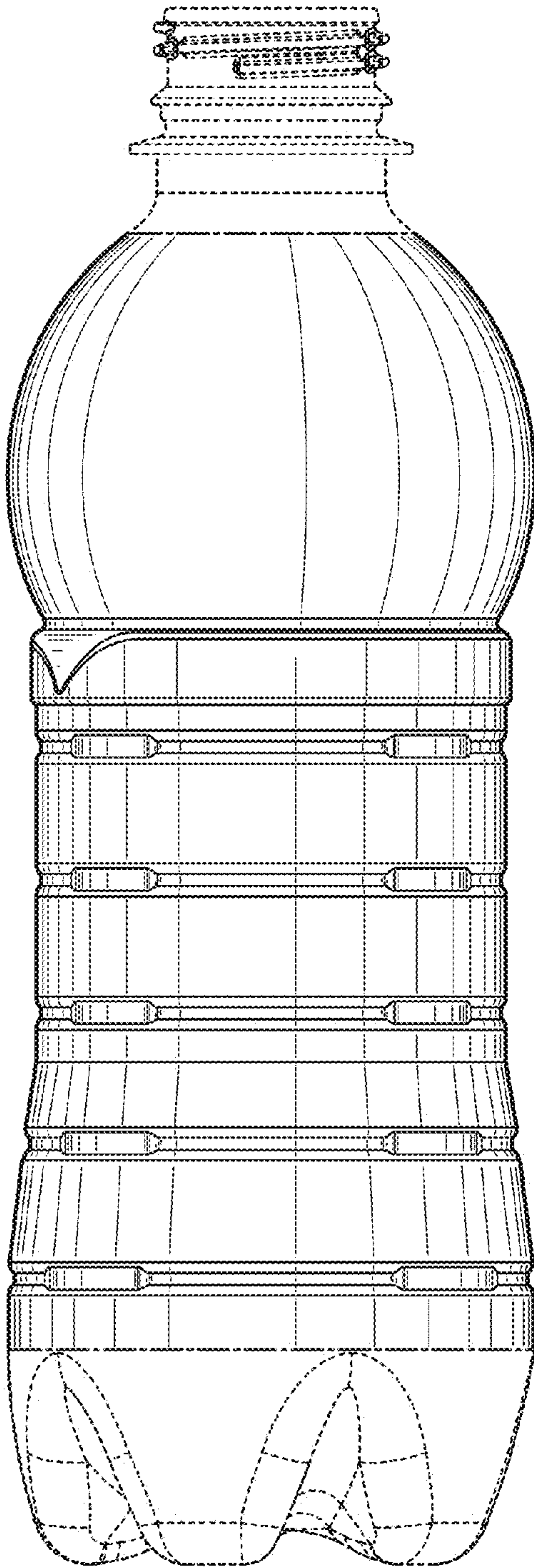

FIG. 9

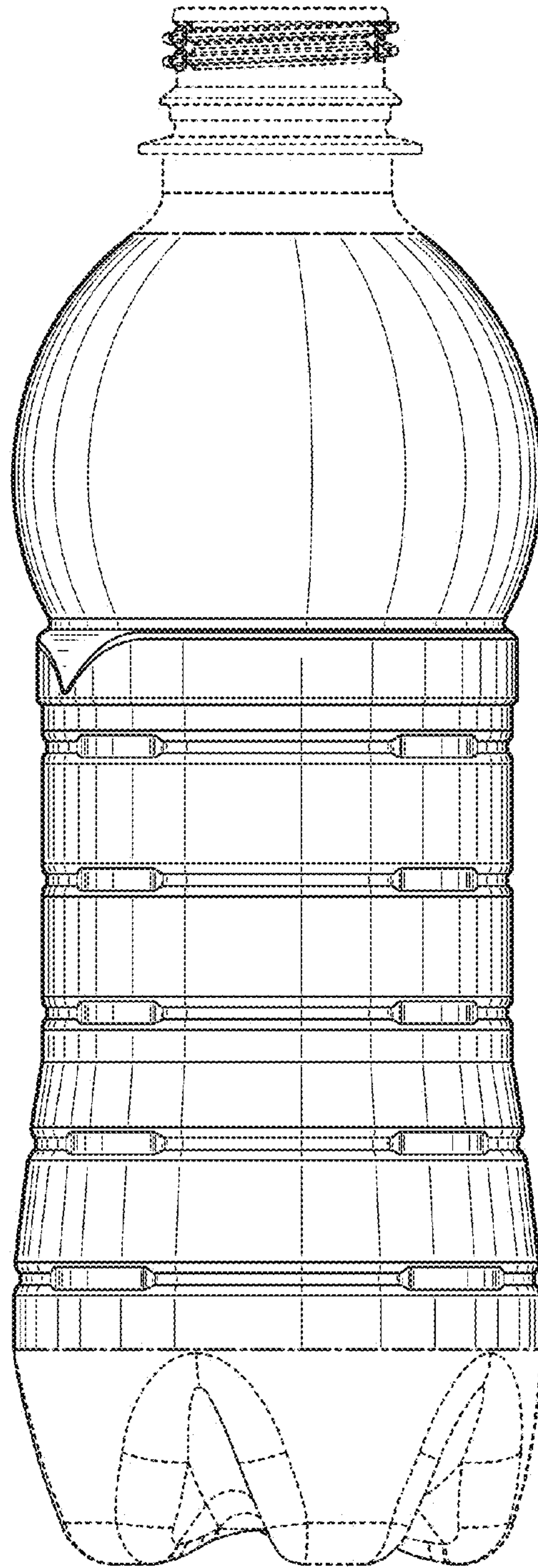

FIG. 10

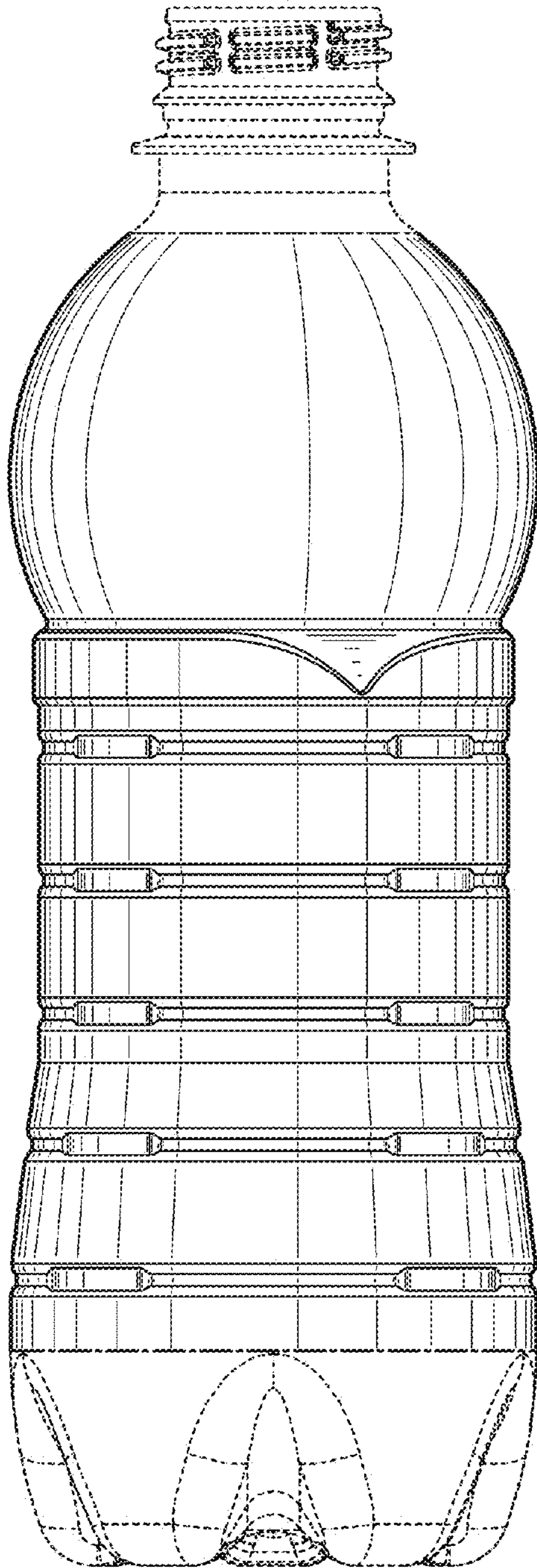

FIG. 11

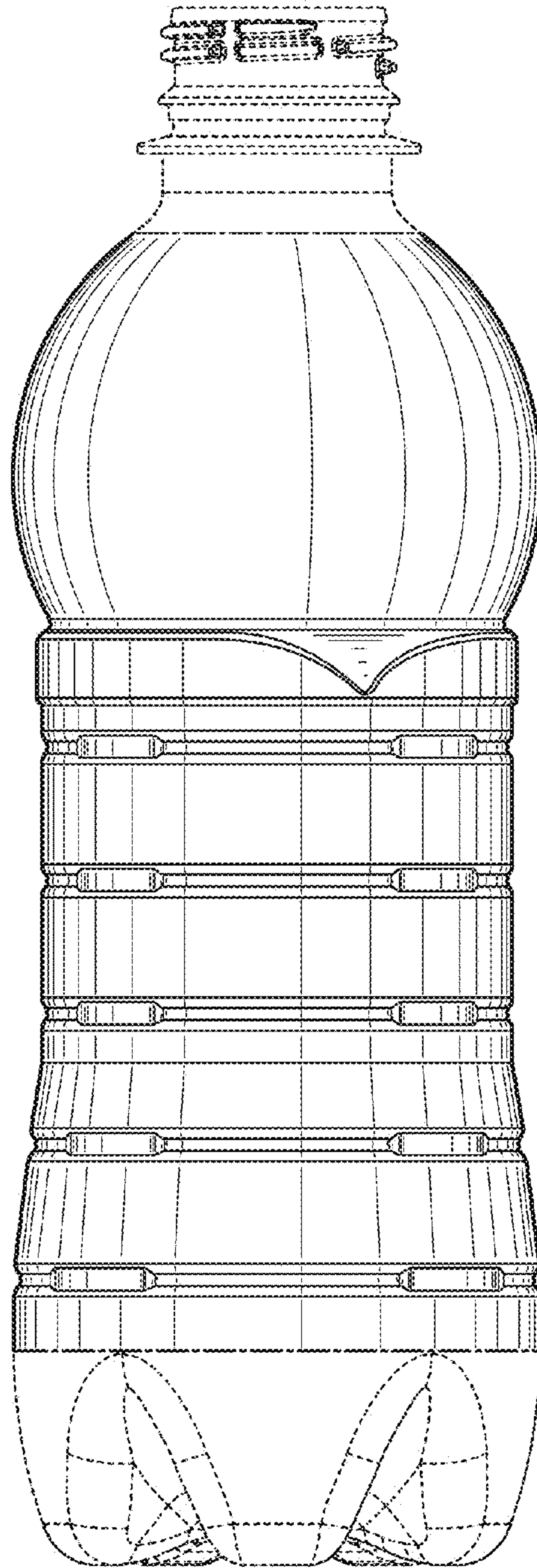

FIG. 12

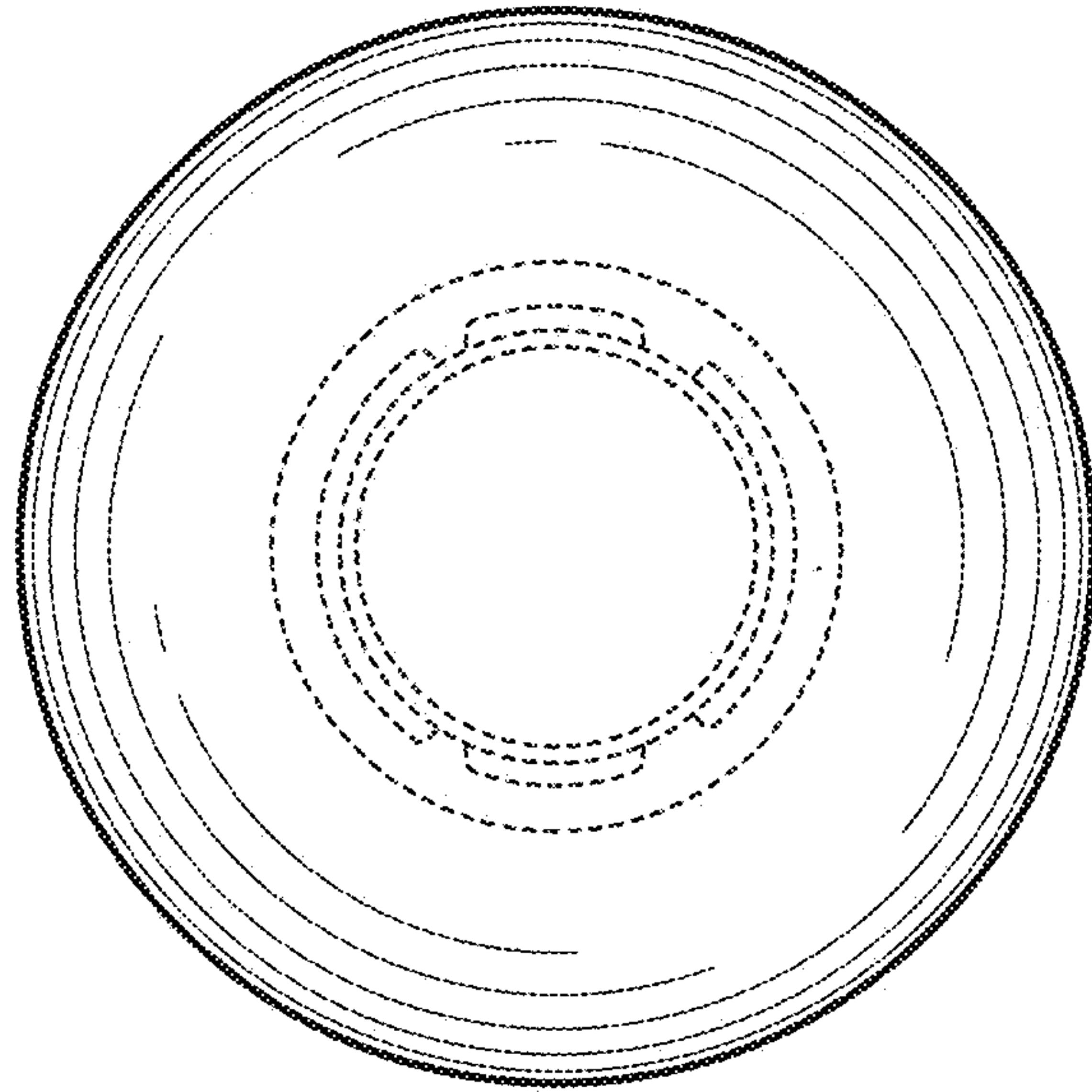

FIG. 13

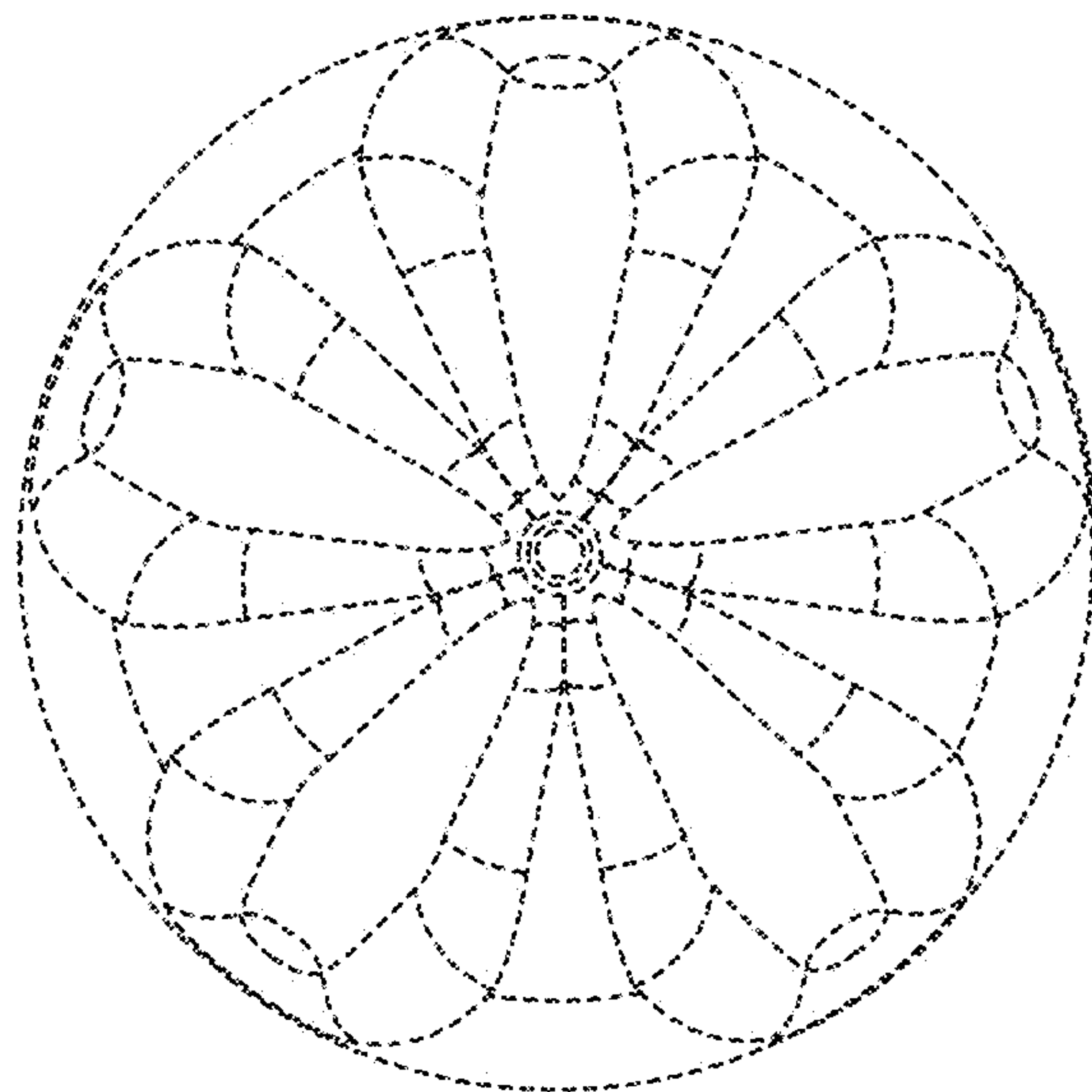

FIG. 14