



US00D763025S

(12) **United States Design Patent**
Walter

(10) **Patent No.:** **US D763,025 S**
(45) **Date of Patent:** **** Aug. 9, 2016**

- (54) **DISPLAY EQUIPMENT**
- (71) Applicant: **Visplay International AG**, MuttENZ,
Birsfelden (CH)
- (72) Inventor: **Herbert Walter**, Müllheim (DE)
- (73) Assignee: **Visplay International AG**, MuttENZ
(CH)
- (**) Term: **15 Years**
- (21) Appl. No.: **29/547,940**
- (22) Filed: **Dec. 9, 2015**

- D335,623 S * 5/1993 Salrin D8/373
- 5,678,794 A * 10/1997 Kump A47F 5/0869
211/59.1
- D420,838 S 2/2000 Riga
- D510,855 S * 10/2005 Tipp D8/374
- 7,100,878 B2 * 9/2006 Shea A47F 5/0807
211/90.02
- D661,309 S 6/2012 Murrer et al.
- D679,209 S 4/2013 Reynolds et al.
- D701,406 S 3/2014 Leyden
- D710,363 S 8/2014 Wengreen
- D722,488 S 2/2015 Lockwood et al.
- D736,858 S 8/2015 McPhillips
- 9,138,078 B2 * 9/2015 Barkdoll A47F 5/0823
- D742,726 S * 11/2015 Glass D8/367

Related U.S. Application Data

- (62) Division of application No. 29/480,127, filed on Jan. 23, 2014.

Foreign Application Priority Data

- Jul. 24, 2013 (WO) DM/081410
- (51) **LOC (10) Cl.** **06-06**
- (52) **U.S. Cl.**
USPC **D6/702**
- (58) **Field of Classification Search**
USPC D6/349, 355, 560, 657, 662.1, 672,
D6/683.1, 675.1, 691.1, 675.3, 702
CPC A47B 57/40; A47B 57/54
See application file for complete search history.

References Cited

U.S. PATENT DOCUMENTS

- 3,897,926 A * 8/1975 Silver A47F 5/0823
248/220.22
- 4,516,681 A * 5/1985 Jahel A47F 5/0823
211/104
- 4,619,428 A * 10/1986 Bailey A47F 5/0823
248/220.43
- D300,003 S * 2/1989 Hutchison 248/220.42
- 4,813,552 A * 3/1989 Walter A47F 5/08
211/105.1

OTHER PUBLICATIONS

Restriction Requirement mailed Oct. 5, 2015, issued in connection with U.S. Appl. No. 29/480,127 (6 pages).

* cited by examiner

Primary Examiner — Kelley Donnelly

(74) *Attorney, Agent, or Firm* — McCarter & English, LLP

(57) **CLAIM**

The ornamental design for display equipment, as shown and described.

DESCRIPTION

FIG. 1 is a front perspective view from above with display equipment whose button is of a circular cross section, the button is pushed in, inserted into a panel and intended for combination with a carrying arm designated for being hooked into the button;

FIG. 2 shows the arrangement of FIG. 1 with the button pushed out;

FIG. 3 shows the arrangement of FIG. 2 from below;

FIG. 4 shows the arrangement of FIG. 2 with a carrying arm drawn towards the button; and,

FIG. 5 shows the arrangement of FIG. 4 with the carrying arm hooked into the button.

1 Claim, 2 Drawing Sheets

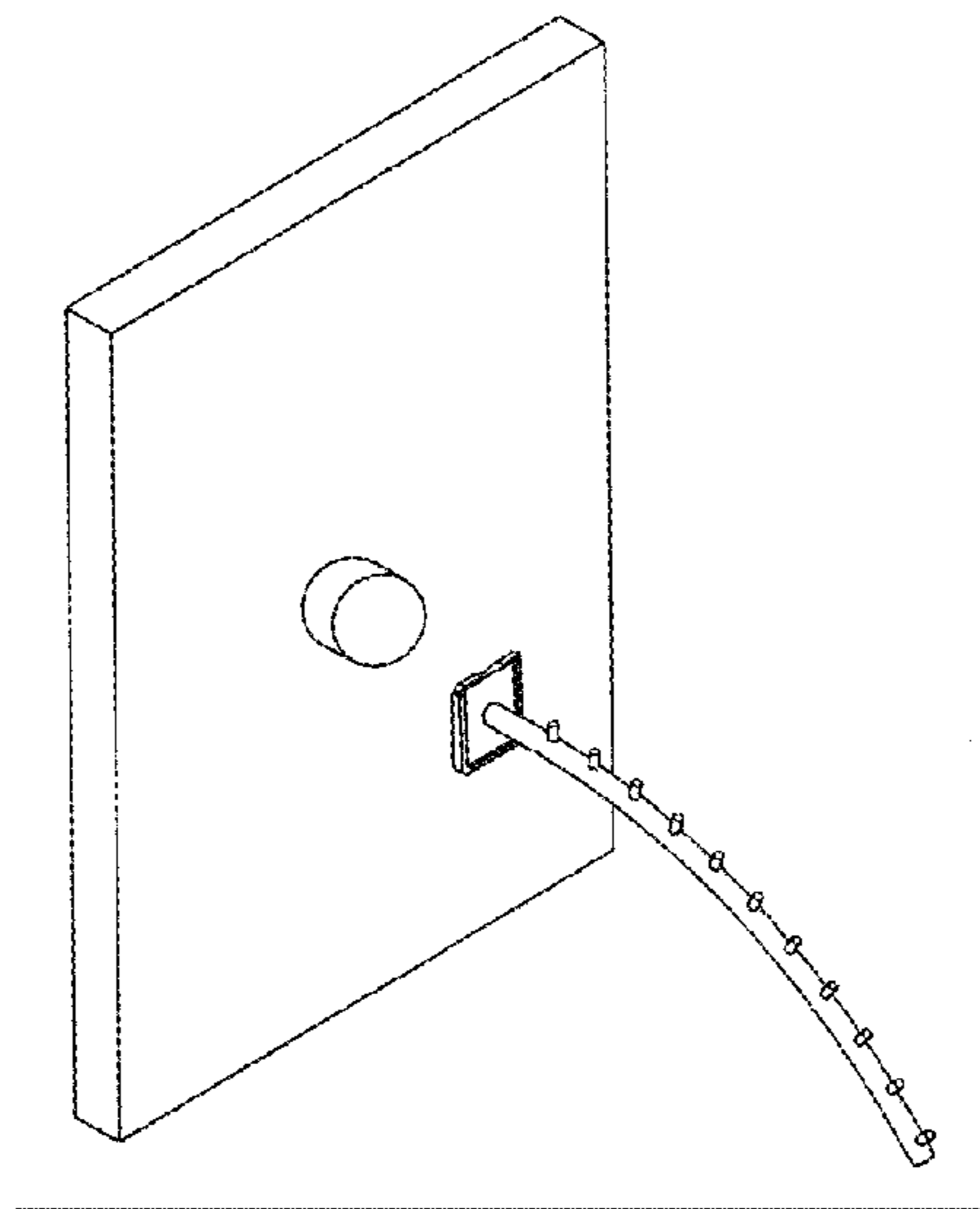

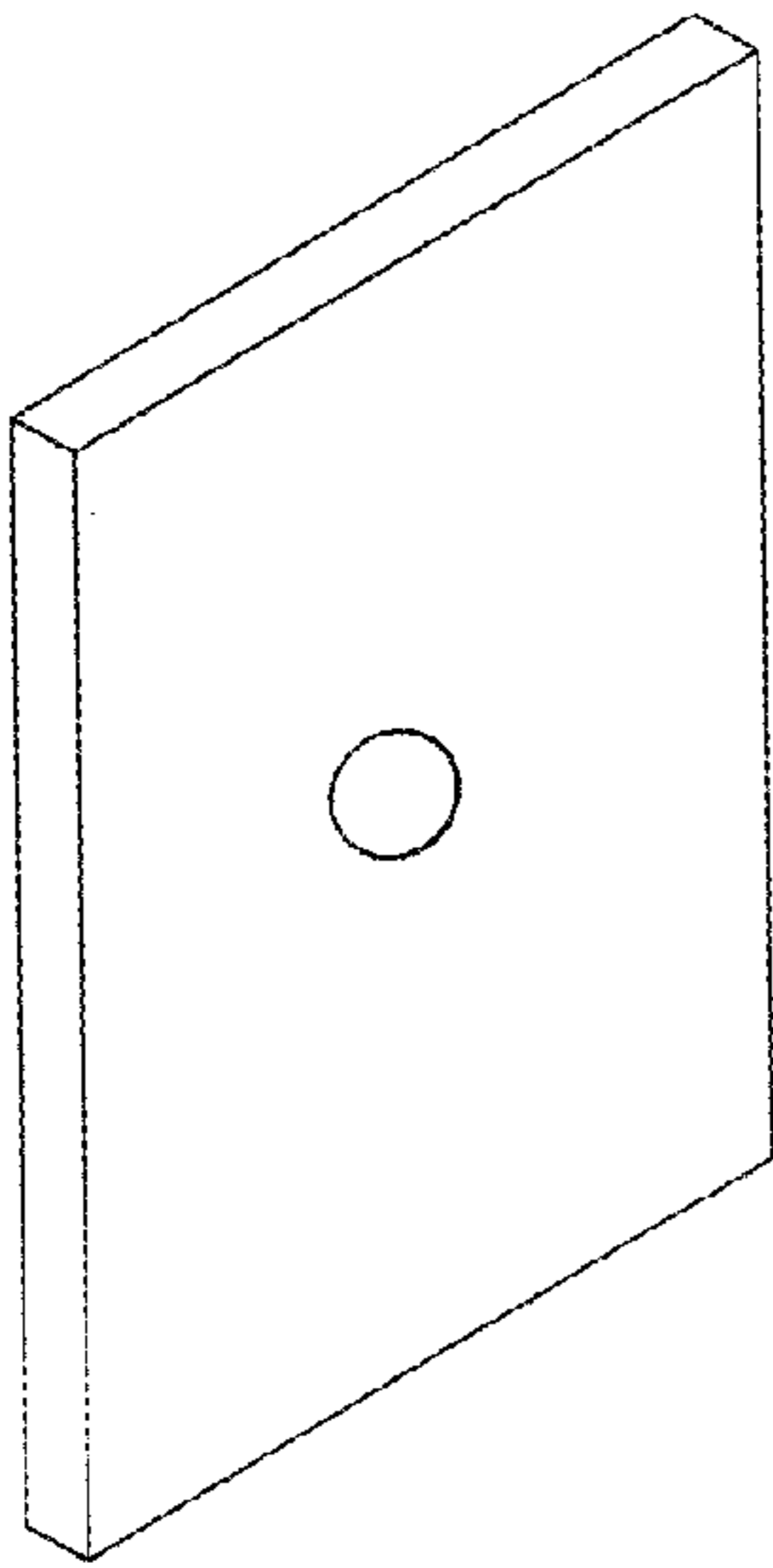

Fig. 1

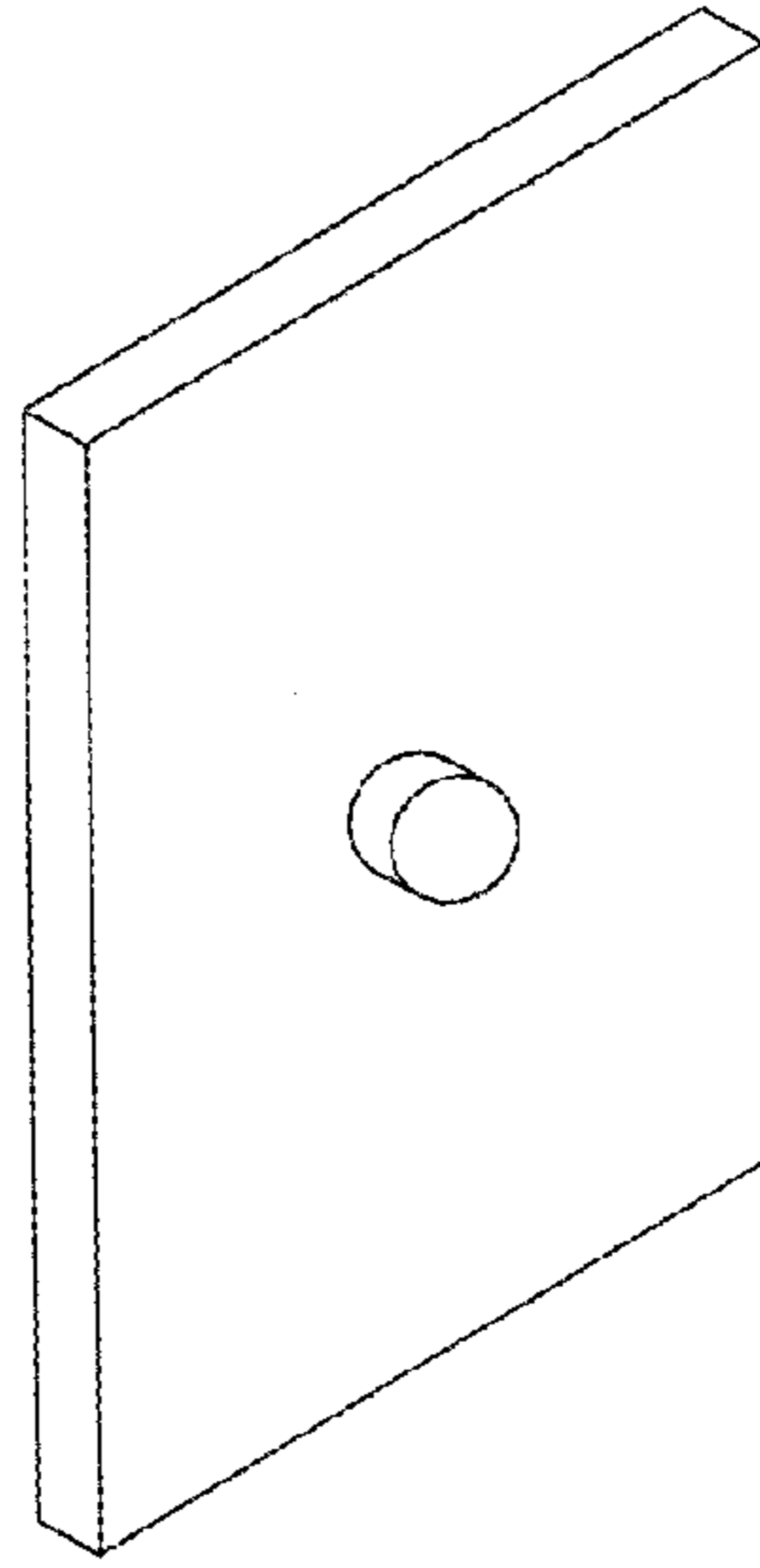

Fig. 2

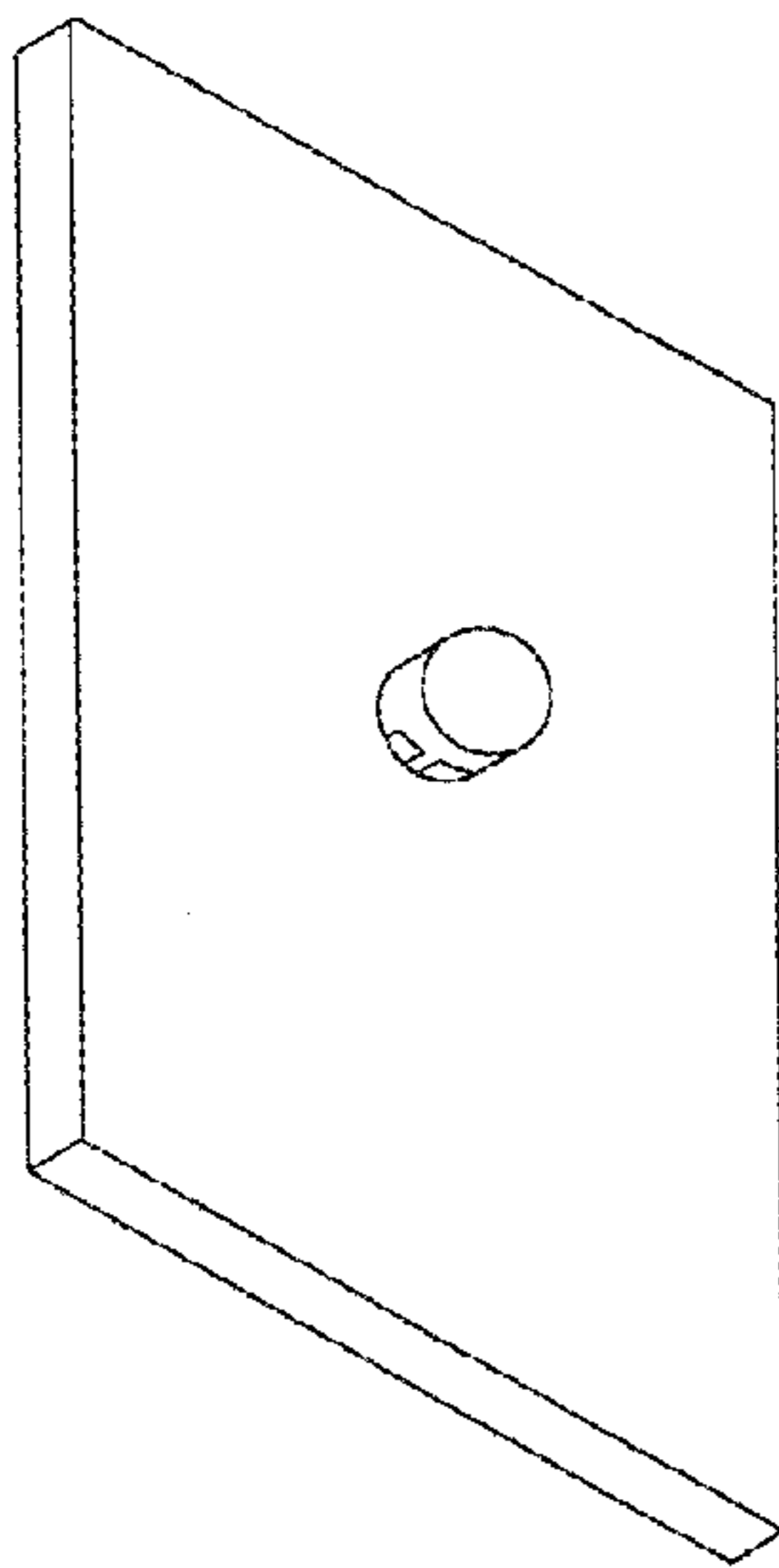

Fig. 3

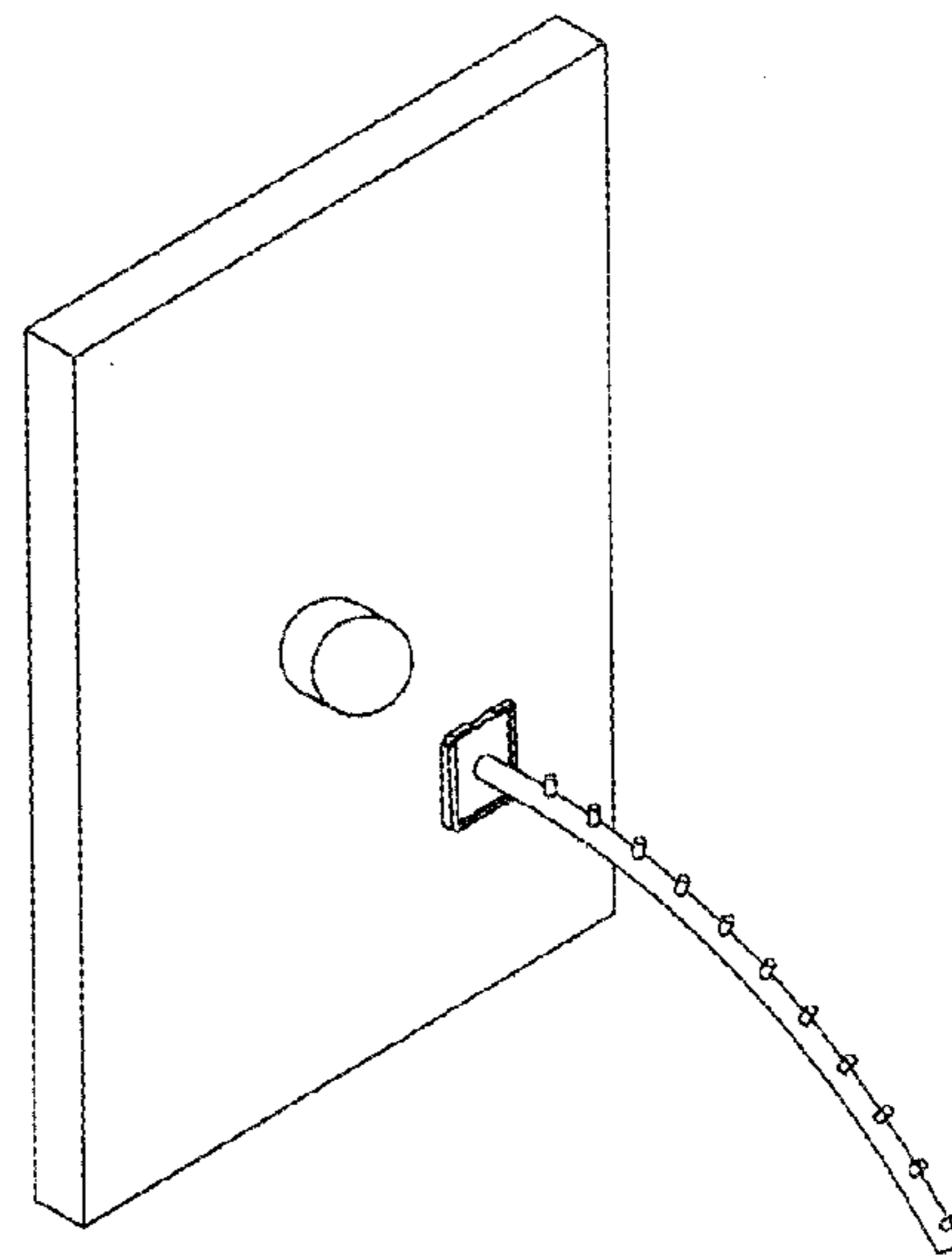

Fig. 4

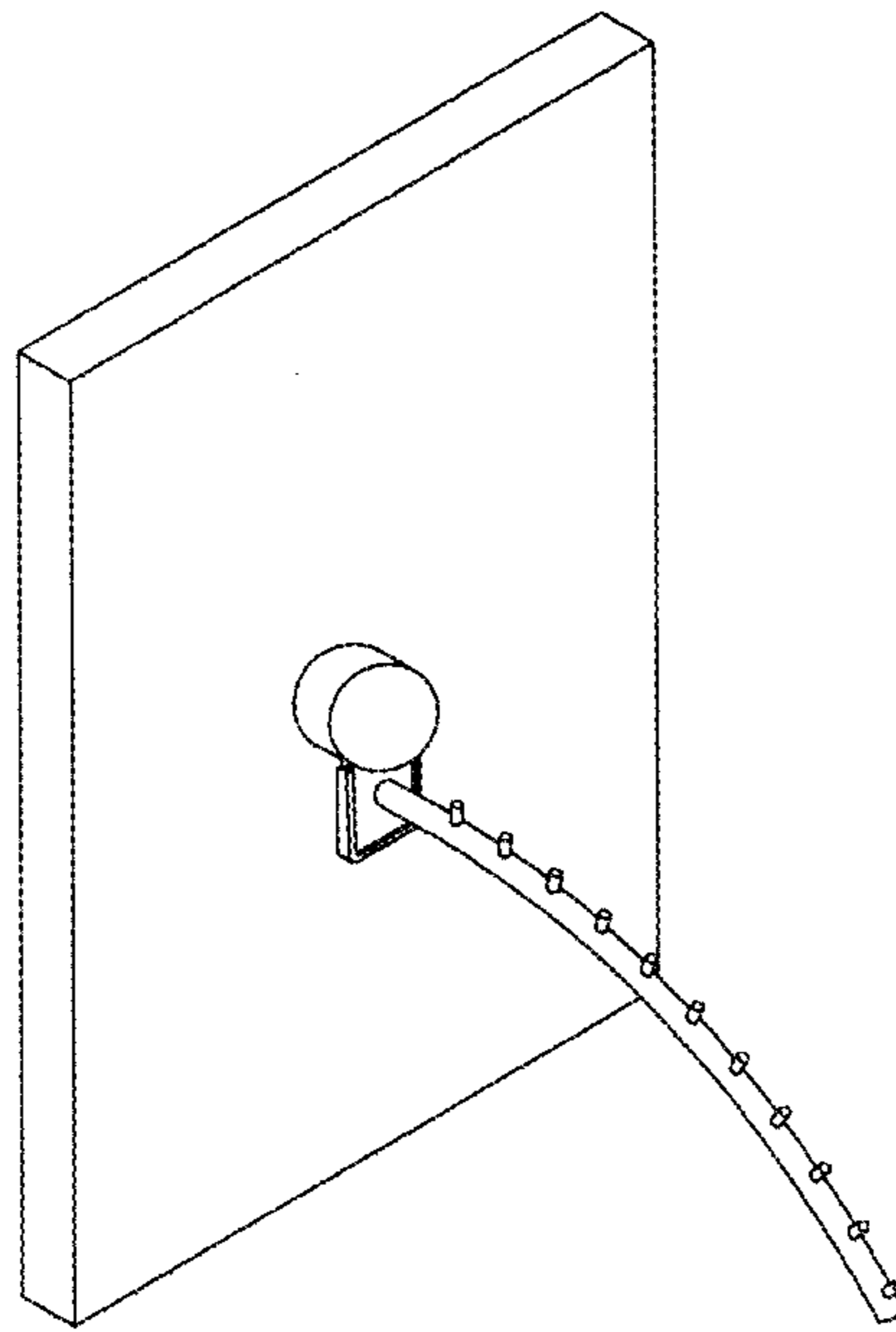

Fig. 5