



US00D762939S

(12) **United States Design Patent**
Johnson et al.

(10) **Patent No.:** **US D762,939 S**
(45) **Date of Patent:** **** Aug. 2, 2016**

(54) **TRANSPORT STRUCTURE**

(71) Applicant: **Ebert Composite Corporation**, Chula Vista, CA (US)

(72) Inventors: **David W. Johnson**, San Diego, CA (US); **Scott A. Garrett**, San Diego, CA (US); **Stephen G. Moyers**, Jamul, CA (US)

(73) Assignee: **Ebert Composite Corporation**, Chula Vista, CA (US)

(**) Term: **15 Years**

(21) Appl. No.: **29/527,122**

(22) Filed: **May 15, 2015**

Related U.S. Application Data

(63) Continuation-in-part of application No. 29/523,453, filed on Apr. 9, 2015.

(51) **LOC (10) Cl.** **09-08**

(52) **U.S. Cl.**
USPC **D34/38**

(58) **Field of Classification Search**
USPC D34/38; 108/51.11, 52.1, 53.1, 55.1, 108/55.3, 55.5, 57.13
CPC B65D 2519/00323; B65D 2519/00293; B65D 2519/00333; B65D 19/385; B65D 19/36

See application file for complete search history.

(56) **References Cited**

U.S. PATENT DOCUMENTS

3,581,681	A *	6/1971	Newton	B65D 19/0018	108/57.28
3,707,929	A *	1/1973	Lauffer	B65D 19/0073	108/57.15
4,838,178	A *	6/1989	Chriske	B65D 19/0026	108/55.1
D419,275	S *	1/2000	Carter	D34/38	
D419,744	S *	1/2000	Carter	D34/38	
D612,567	S *	3/2010	Carter	D34/38	
2001/0050034	A1 *	12/2001	Gross	B65D 19/0081	108/51.11
2006/0288914	A1 *	12/2006	Lee	B65D 19/0038	108/51.11
2008/0250986	A1 *	10/2008	Boon	B65D 88/005	108/53.1
2011/0239910	A1 *	10/2011	Chambless	B32B 38/0004	108/57.16

* cited by examiner

Primary Examiner — Cynthia Ramirez

(74) *Attorney, Agent, or Firm* — Procopio Cory Hargreaves and Savitch LLP

(57) **CLAIM**

The ornamental design for a transport structure, as shown and described.

DESCRIPTION

FIG. 1 is a perspective view of the transport structure showing our new design;
FIG. 2 is a front elevational view of the transport structure, the rear elevational view being a mirror image thereof;
FIG. 3 is a left side elevational view of the transport structure, the right side elevational view being a mirror image thereof;
FIG. 4 is a top plan view of the transport structure; and,
FIG. 5 is a bottom plan view of the transport structure.

1 Claim, 3 Drawing Sheets

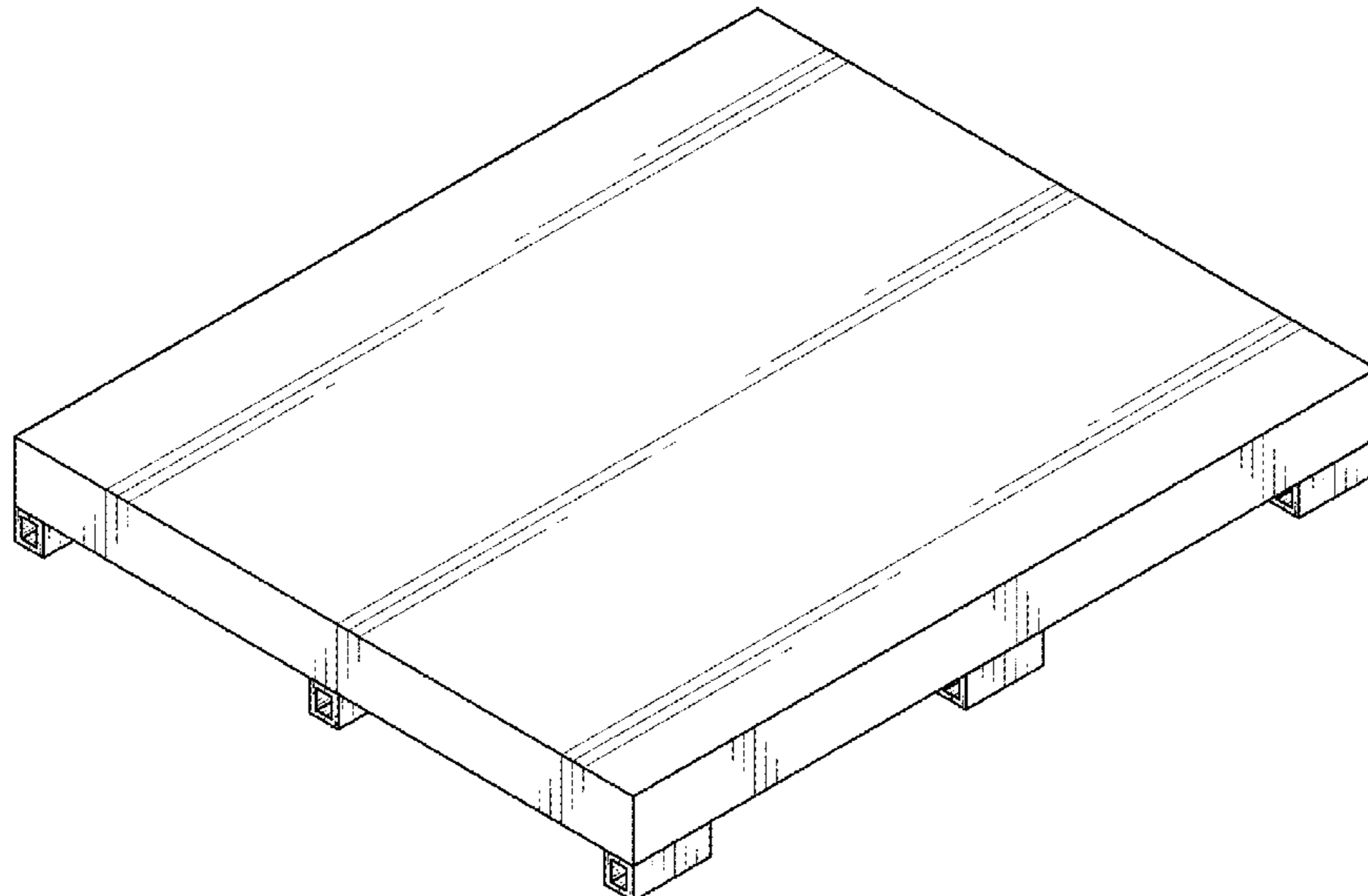

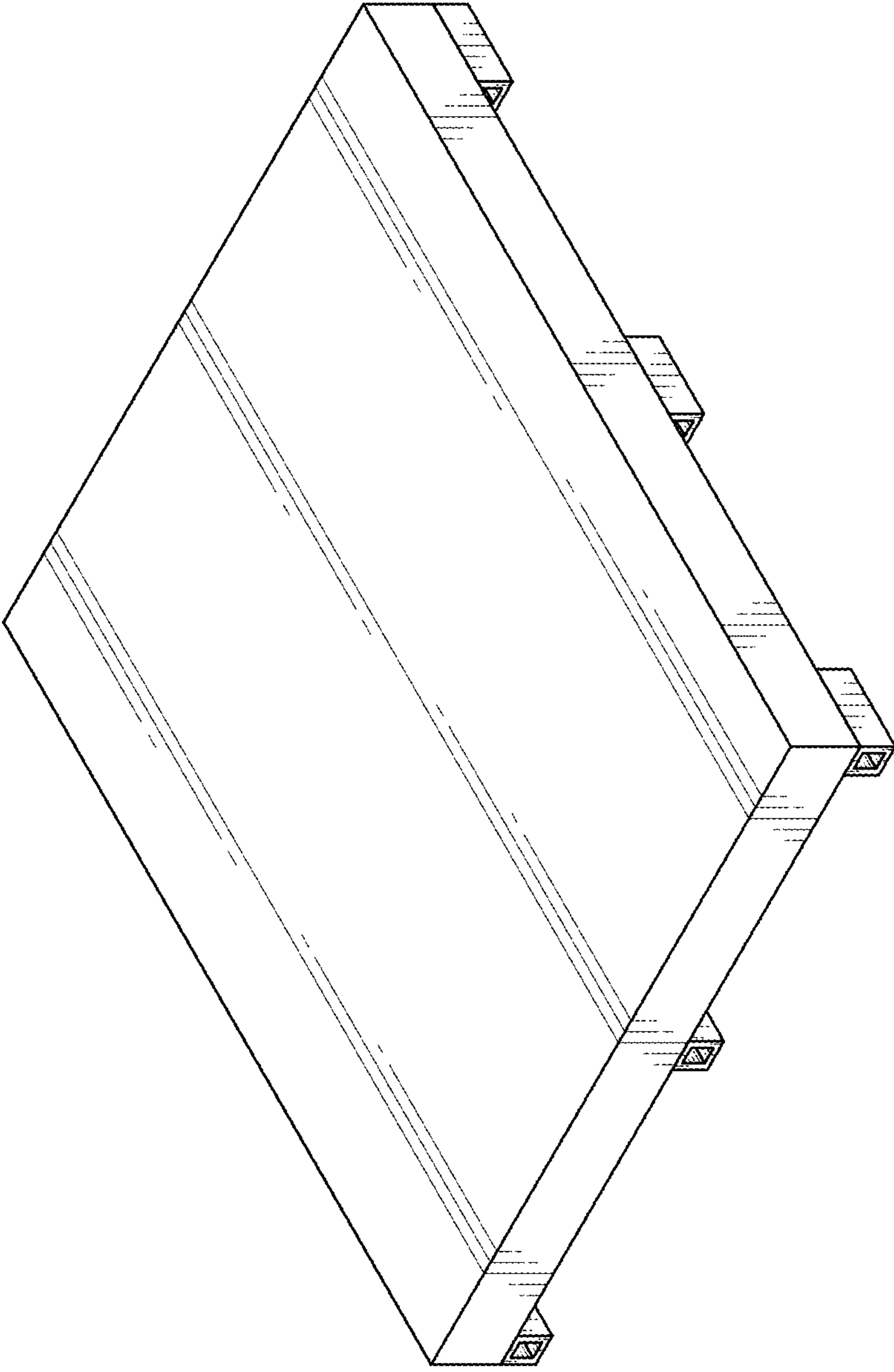

FIG. 1

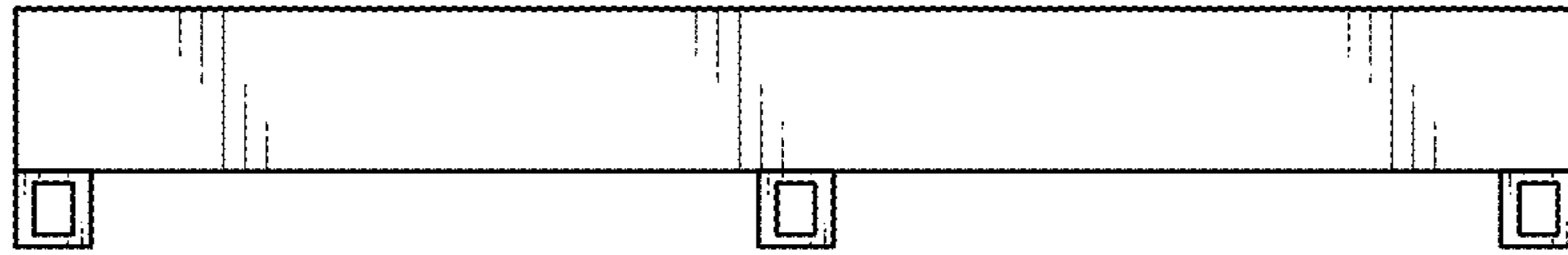

FIG. 2

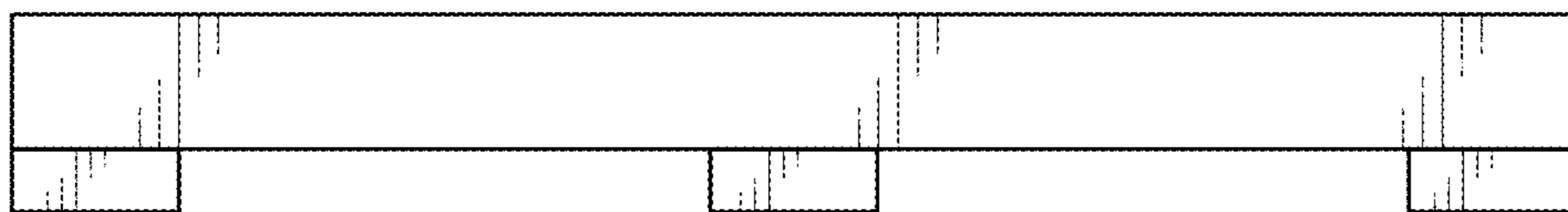

FIG. 3

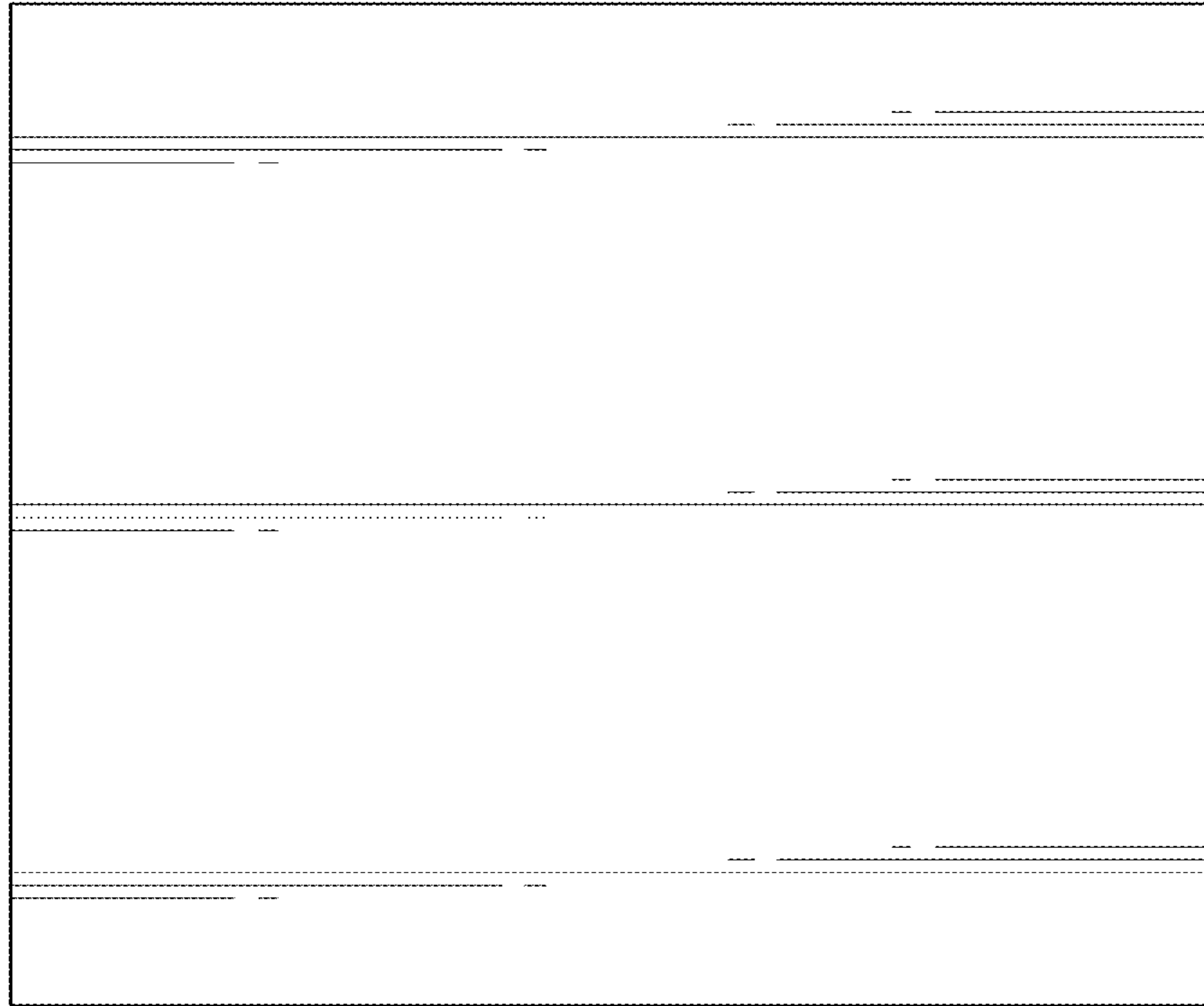

FIG. 4

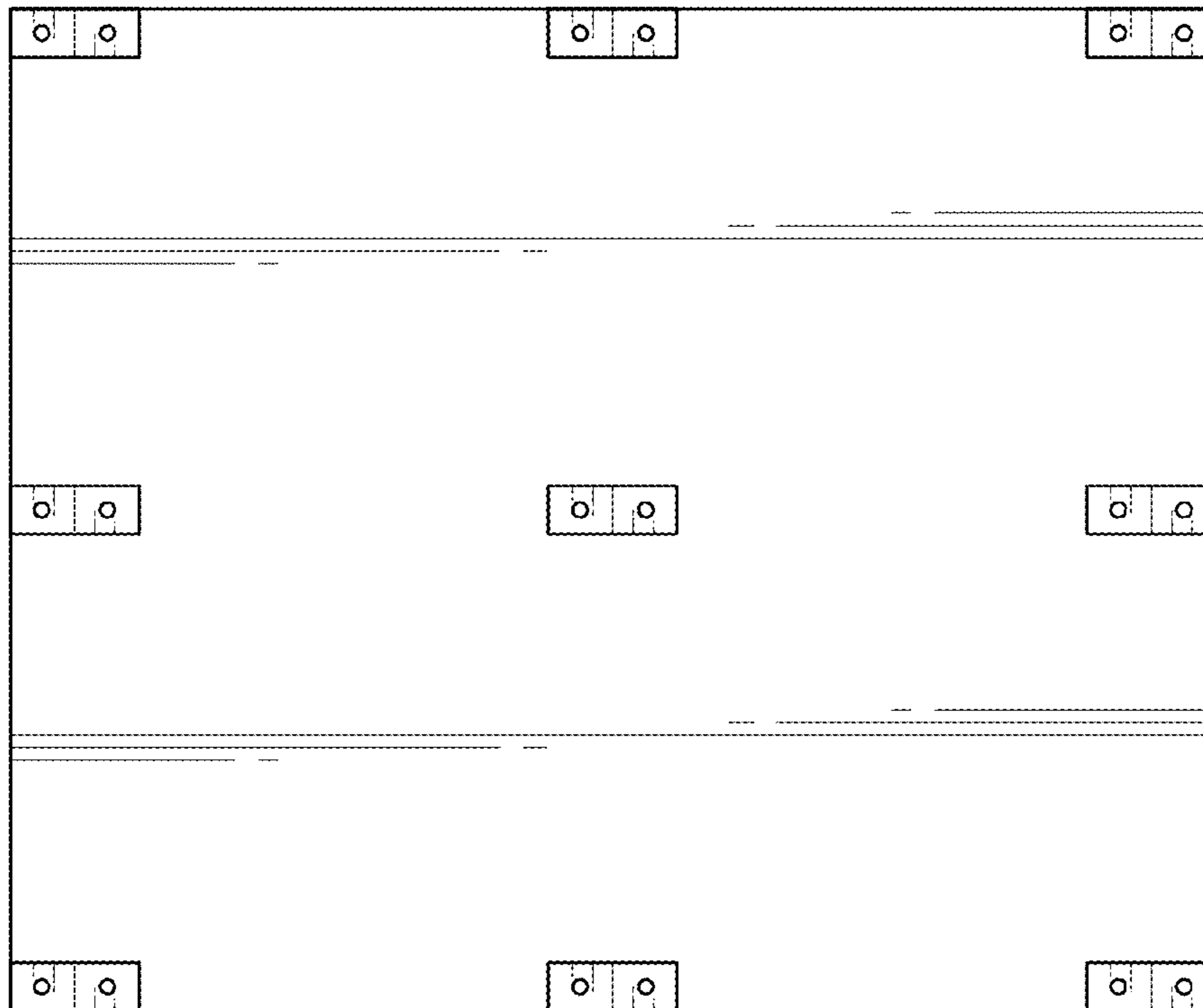

FIG. 5