

US00D762779S

(12) **United States Design Patent**
Gibson et al.

(10) **Patent No.:** **US D762,779 S**
(45) **Date of Patent:** **** Aug. 2, 2016**

(54) **VIDEO GAME PORTAL**

(56) **References Cited**

(71) Applicants: **Brent Gibson**, Mechanicville, NY (US);
Jin Young Han, Hacienda Heights, CA (US)

U.S. PATENT DOCUMENTS

(72) Inventors: **Brent Gibson**, Mechanicville, NY (US);
Jin Young Han, Hacienda Heights, CA (US)

5,672,108	A *	9/1997	Lam	F41G 3/2655
					463/2
6,120,379	A *	9/2000	Tanaka	A63F 13/08
					273/148 B
6,227,966	B1 *	5/2001	Yokoi	A63F 13/005
					446/143
D449,655	S *	10/2001	Yamanaka	D21/329
D487,116	S *	2/2004	Bedford	D21/329
D522,587	S *	6/2006	Yokoi	D21/324
D526,025	S *	8/2006	Watanabe	D21/324
D594,909	S *	6/2009	Tam	D21/324
D742,972	S *	11/2015	Corrigan	D21/324
D749,679	S *	2/2016	Bala	D14/496

(73) Assignee: **Activision Publishing, Inc.**, Santa Monica, CA (US)

(**) Term: **14 Years**

* cited by examiner

(21) Appl. No.: **29/526,293**

Primary Examiner — Prabhakar Deshmukh

(22) Filed: **May 7, 2015**

(74) *Attorney, Agent, or Firm* — Klein, O'Neill & Singh, LLP

(51) **LOC (10) Cl.** **21-01**

(57) **CLAIM**

The ornamental design for a video game portal, as shown and described.

(52) **U.S. Cl.**

DESCRIPTION

USPC **D21/329**

(58) **Field of Classification Search**

USPC D14/496, 401, 435, 474, 483, 217, 137,
D14/138, 160, 168, 356, 203.1–203.8, 507;
345/156, 169, 173–179, 905;
715/727–729, 864, 700, 706, 719;
710/1, 5, 8; 713/1, 600; 455/1.1, 1.7,
455/73, 344–347, 93, 95, 3.01–3.06, 550.1,
455/573.1; 370/342–344; 369/1, 2, 6–12;
463/51–57, 40–47, 1, 29–35; D21/324,
D21/328, 333; 273/148 B
CPC A63F 13/00; A63F 13/02; A63F 9/00;
G06F 17/00; G06F 19/00

FIG. 1 is a perspective view of a video game portal embodying our new design;
FIG. 2 is a top view of the video game portal of FIG. 1;
FIG. 3 is a bottom view of the video game portal of FIG. 1;
FIG. 4 is a left side view of the video game portal of FIG. 1;
FIG. 5 is a right side view of the video game portal of FIG. 1;
FIG. 6 is a rear view of the video game portal of FIG. 1;
and,
FIG. 7 is a front view of the video game portal of FIG. 1.
The broken lines environment is for illustrative purpose only and forms no part of the claimed design.

See application file for complete search history.

1 Claim, 5 Drawing Sheets

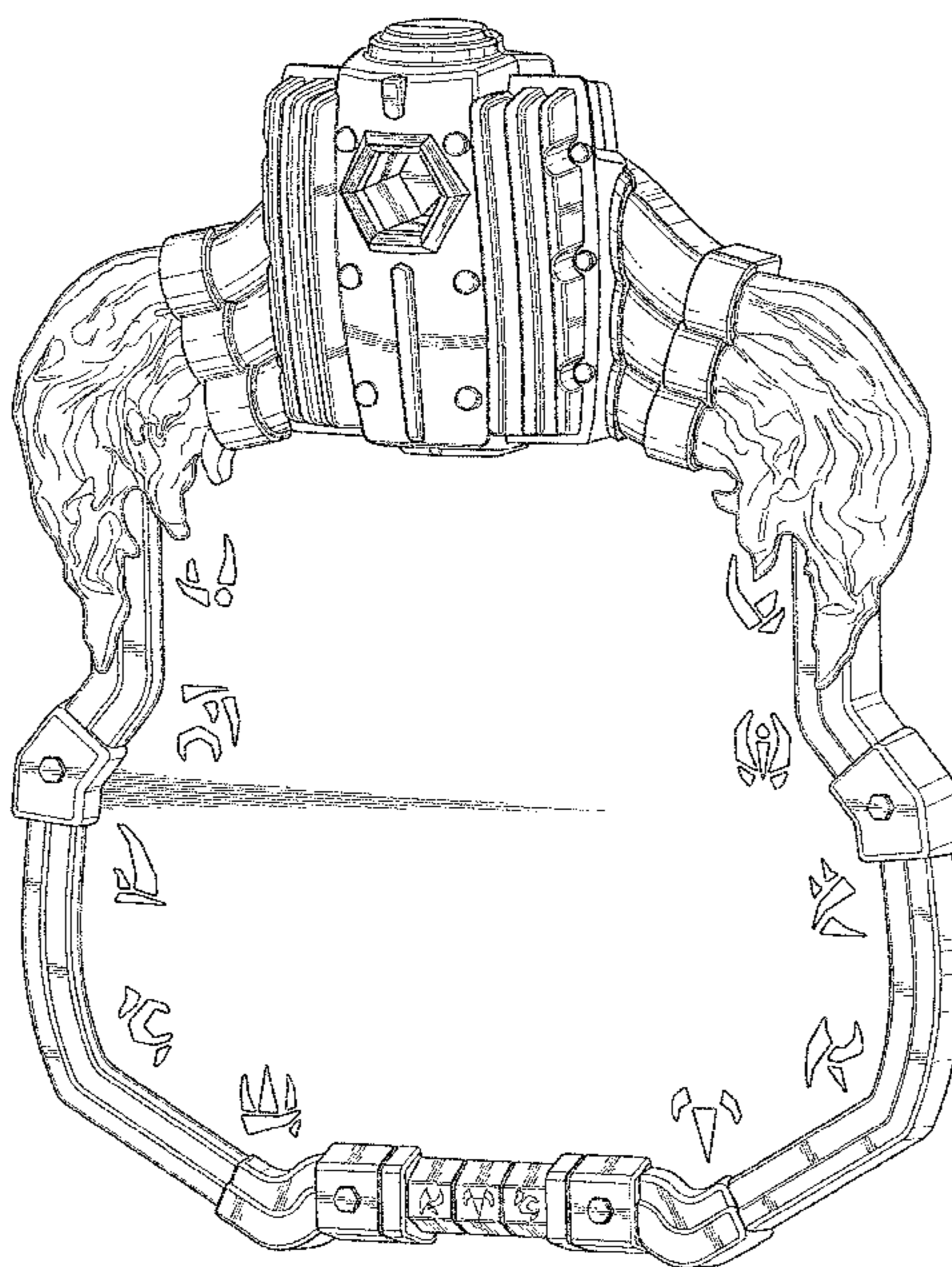

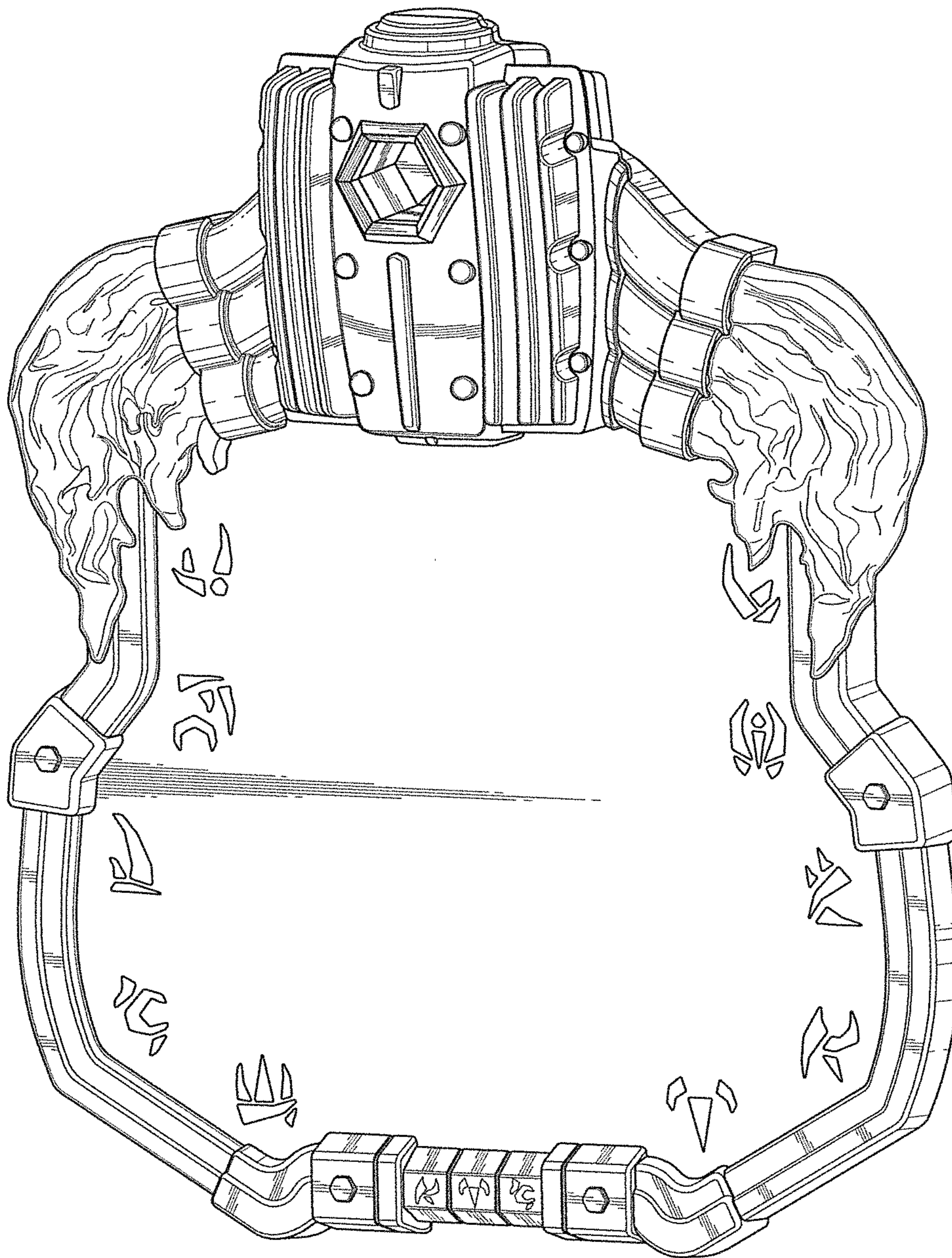

FIG. 1

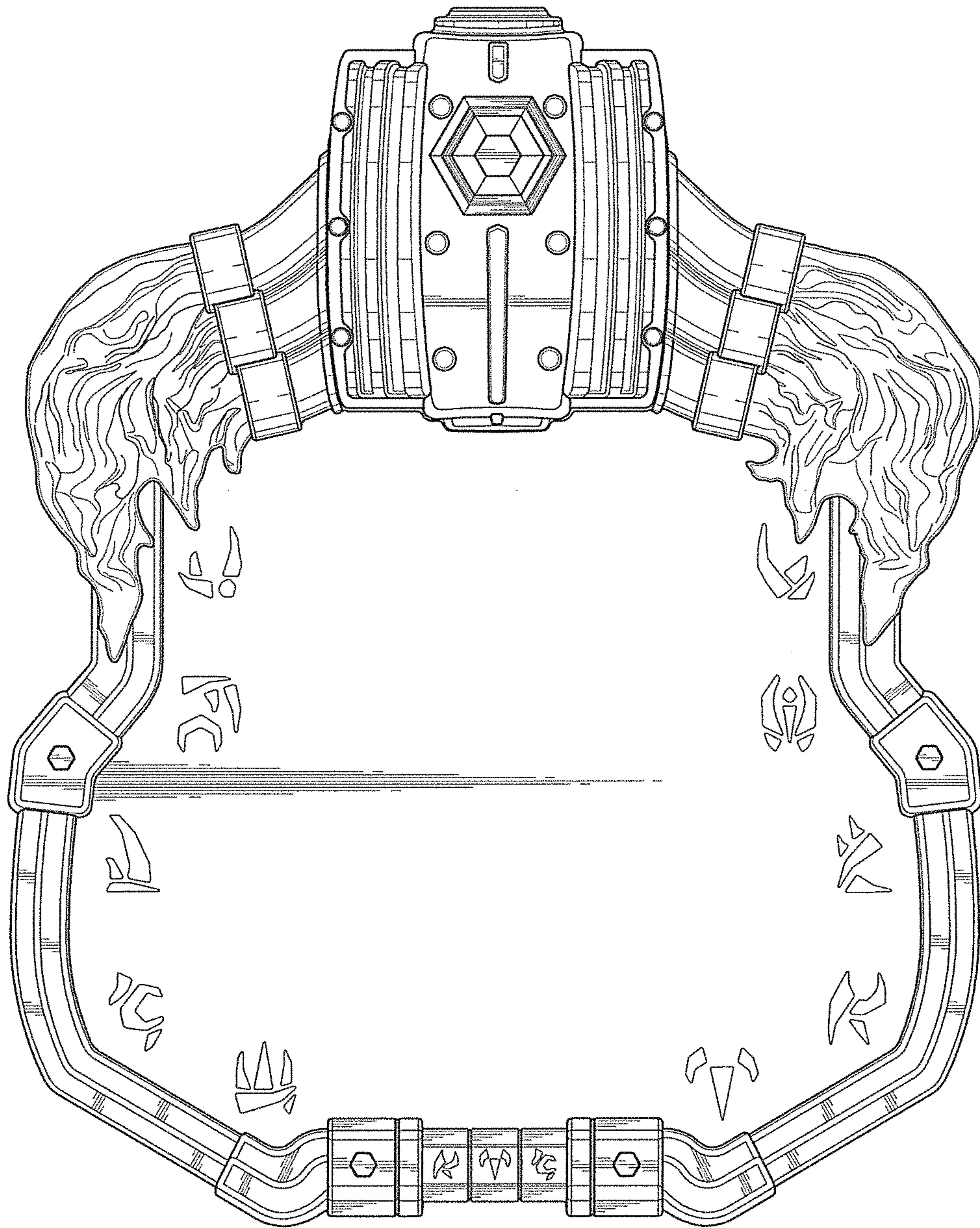

FIG. 2

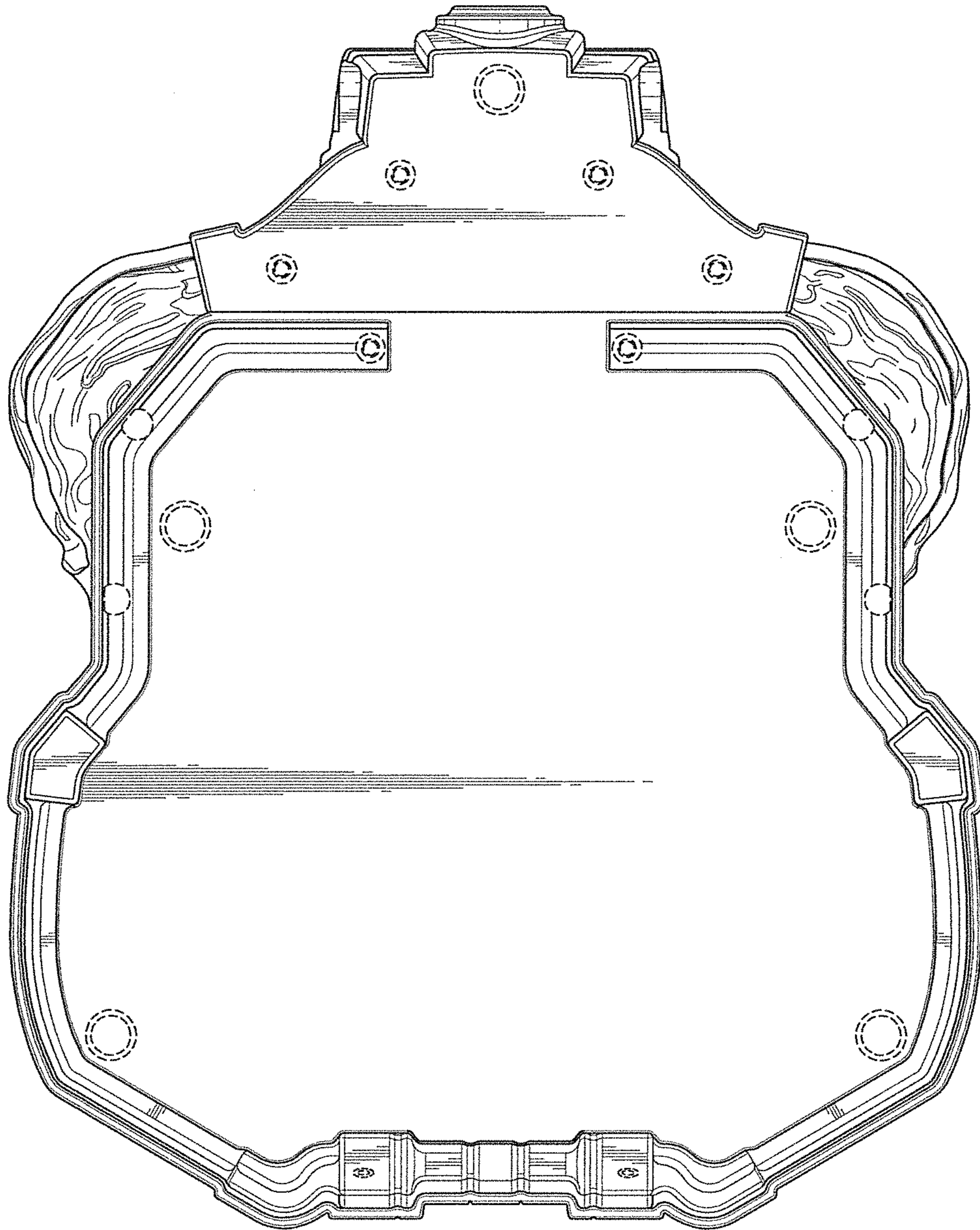

FIG. 3

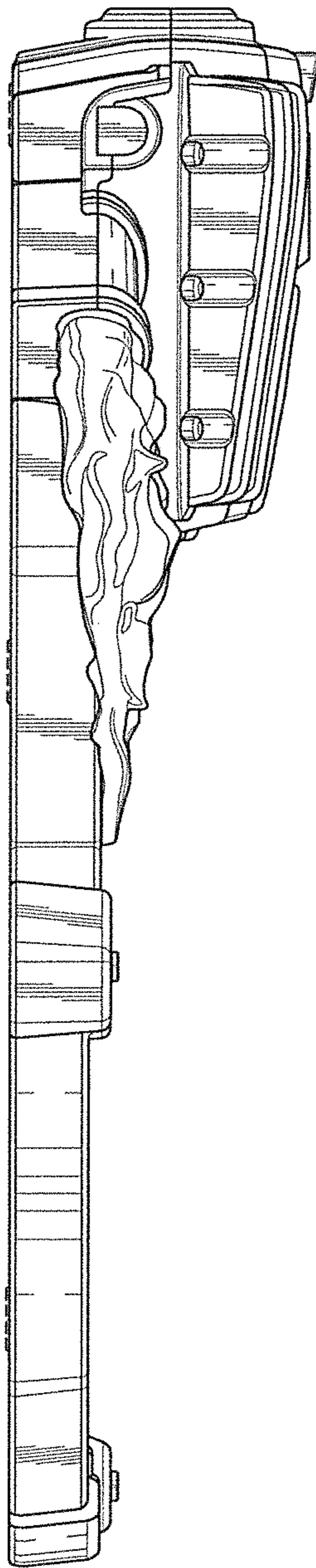

FIG. 4

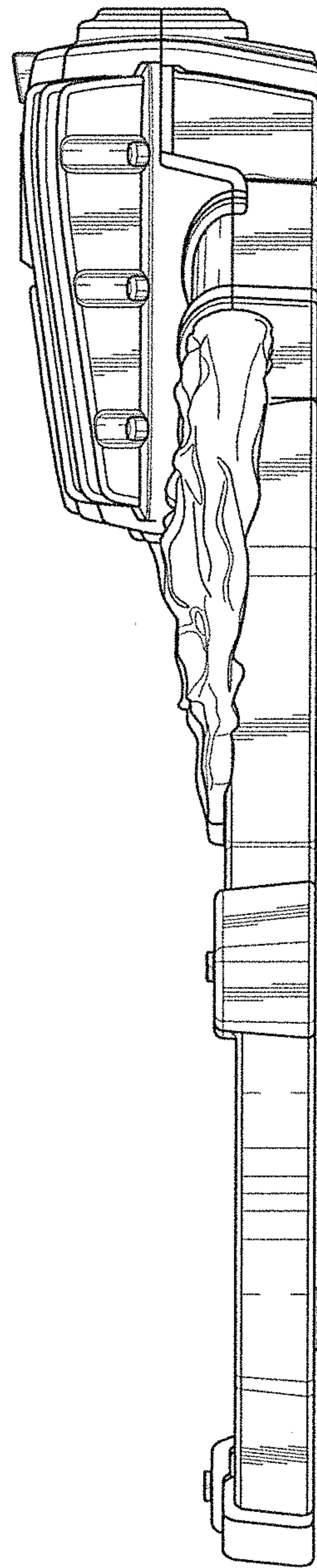

FIG. 5

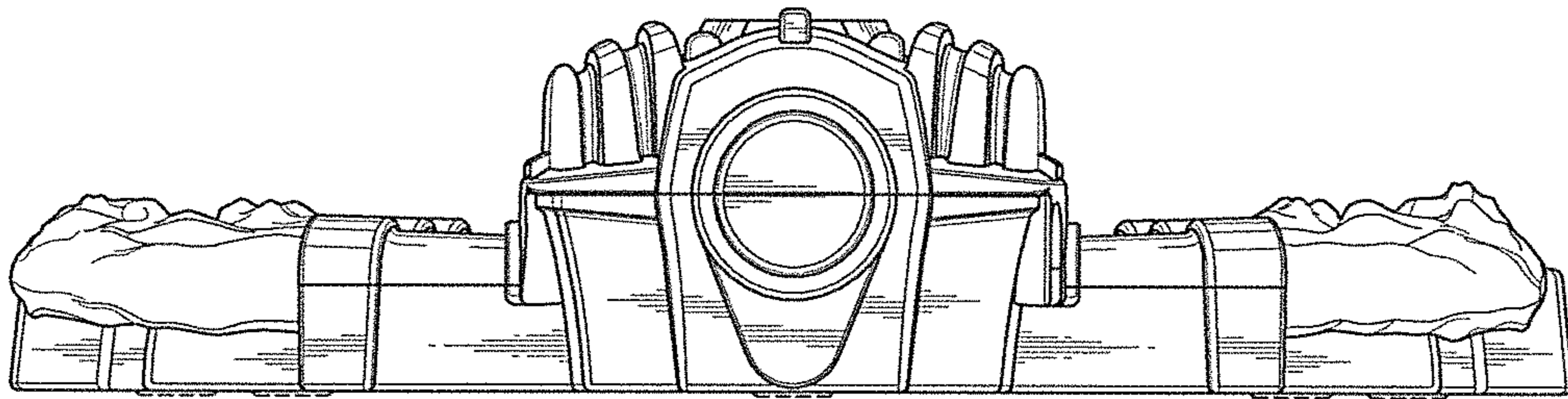

FIG. 6

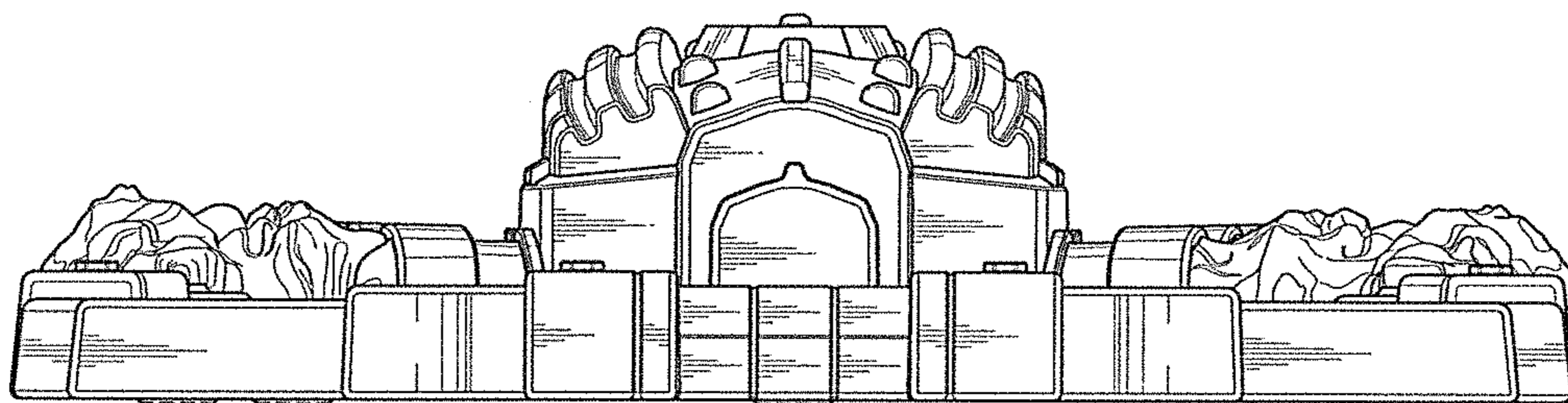

FIG. 7