



US00D762549S

(12) **United States Design Patent**
Paulino et al.

(10) **Patent No.:** **US D762,549 S**

(45) **Date of Patent:** **** Aug. 2, 2016**

(54) **COMBINED AIRCRAFT PASSENGER SERVICE UNIT**

(71) Applicant: **EMBRAER S.A.**, São José dos Campos, SP (BR)

(72) Inventors: **Amauri Paulino**, São José dos Campos (BR); **Sergio Luiz Abdalla Gomide**, São José dos Campos (BR); **Gustavo Selofite De Arruda**, São José dos Campos (BR); **Nilmar César Ferreira**, São José dos Campos (BR); **Luciano Dos Santos Ribeiro**, São José dos Campos (BR); **Demétrio Andrade De Campos**, São José dos Campos (BR); **Sergio Augusto Meireles Filho**, São José dos Campos (BR); **Frederico Lara De Oliveira**, São José dos Campos (BR); **Douglas Gonçalves De Albuquerque**, São José dos Campos (BR); **Helio Albino**, São José dos Campos (BR); **André Duarte Stein**, São José dos Campos (BR); **Paul Priestman**, London (GB); **Daniel Macinnes**, London (GB); **Luciano Ricardo Magalhães Da Silva**, São José dos Campos (BR); **Ricardo Rosa Macedo**, São José dos Campos (BR)

(73) Assignee: **EMBRAER S.A.**, São José dos Campos-SP (BR)

(**) Term: **14 Years**

(21) Appl. No.: **29/469,017**

(22) Filed: **Oct. 4, 2013**

(51) **LOC (10) Cl.** **12-07**

(52) **U.S. Cl.**
USPC **D12/345**

(58) **Field of Classification Search**

USPC D12/319–345, 195, 418

CPC B64D 11/00; B64D 11/0015; B64D

2011/0053; B64D 2013/003; B60Q 3/00;

B60Q 3/02

See application file for complete search history.

(56) **References Cited**

U.S. PATENT DOCUMENTS

3,370,813 A * 2/1968 Albertine et al. 244/118.5

D213,144 S * 1/1969 Kraus et al. D12/195

(Continued)

Primary Examiner — Martie K Holtje

(74) *Attorney, Agent, or Firm* — Nixon & Vanderhye P.C.

(57) **CLAIM**

The ornamental design for combined aircraft passenger service unit, as shown and described.

DESCRIPTION

FIG. 1 is a bottom perspective view of a combined aircraft passenger service unit showing our new design; and,

FIG. 2 is a bottom plan view thereof.

FIGS. 1 and 2 show the combined aircraft passenger service unit as it would appear on the starboard side of the aircraft, the appearance of the combined aircraft passenger service unit on the port side of the aircraft being a mirror image thereof.

The broken lines in FIGS. 1 and 2 have been shown to illustrate environment that forms no part of the claimed design.

The dot-dashed lines in FIG. 2 represent a boundary that does not form part of the claimed design.

1 Claim, 2 Drawing Sheets

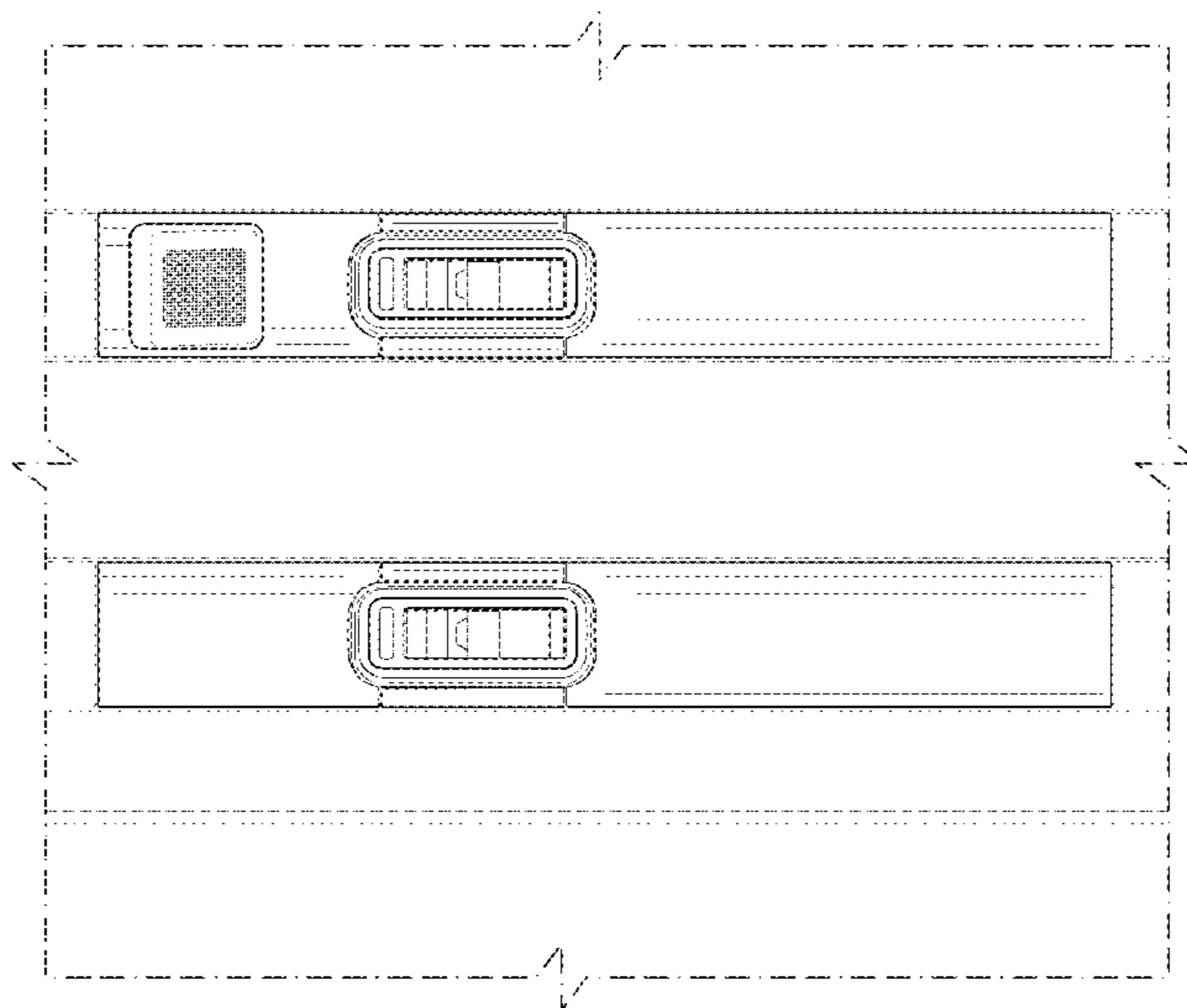

(56)

References Cited

U.S. PATENT DOCUMENTS

D244,018 S * 4/1977 Greiss et al. D12/195
D261,387 S * 10/1981 Weitz et al. D12/192
D281,940 S * 12/1985 Steventon et al. D6/492
D339,780 S * 9/1993 Burdick D12/418

5,707,028 A * 1/1998 Roeper 244/118.5
6,454,209 B1 * 9/2002 Bock et al. 244/118.5
7,567,186 B2 * 7/2009 Endress et al. 340/945
2009/0079705 A1 * 3/2009 Szelove et al. 345/173
2012/0032027 A1 * 2/2012 Gehm et al. 244/118.5

* cited by examiner

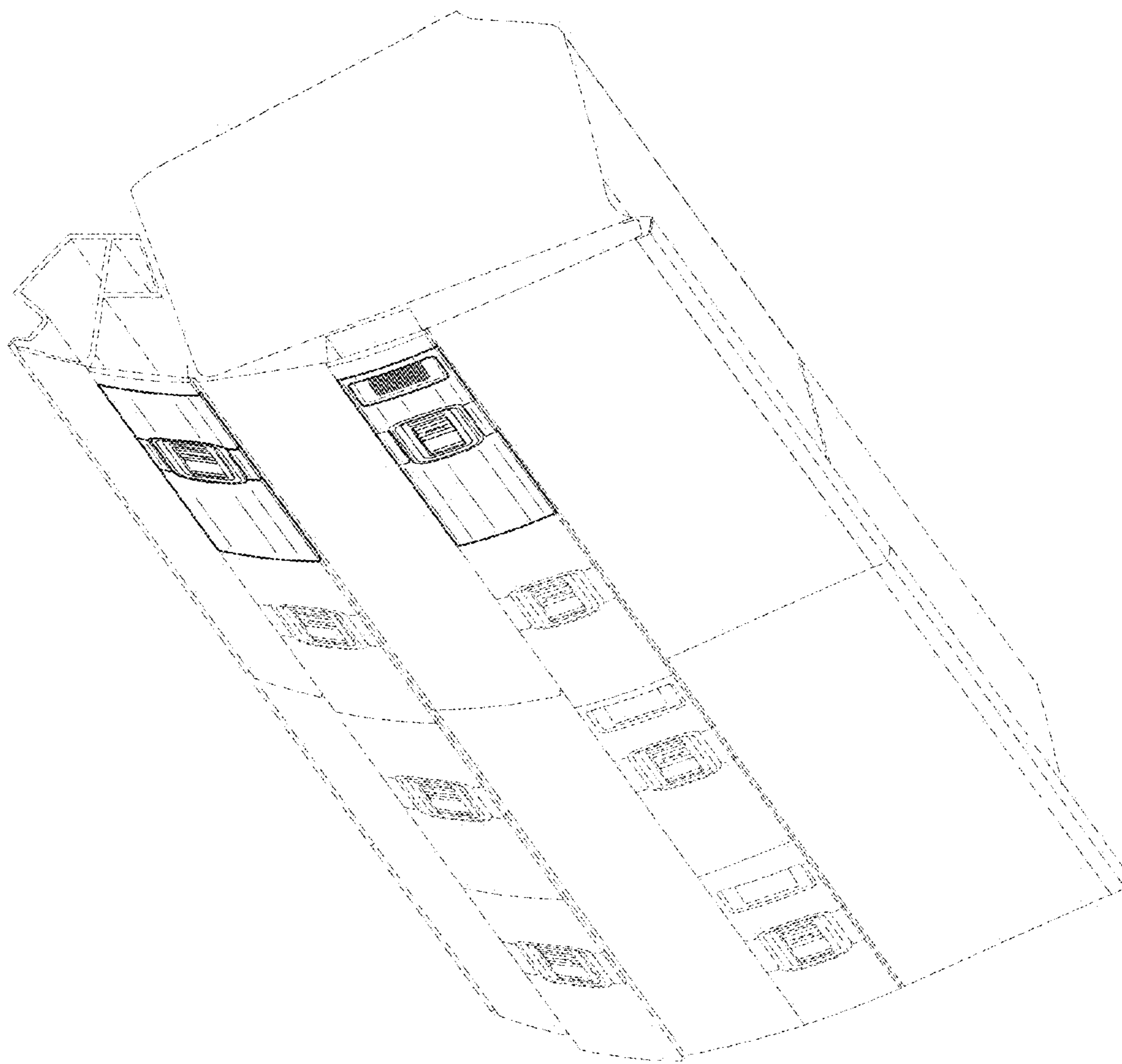

FIG. 1

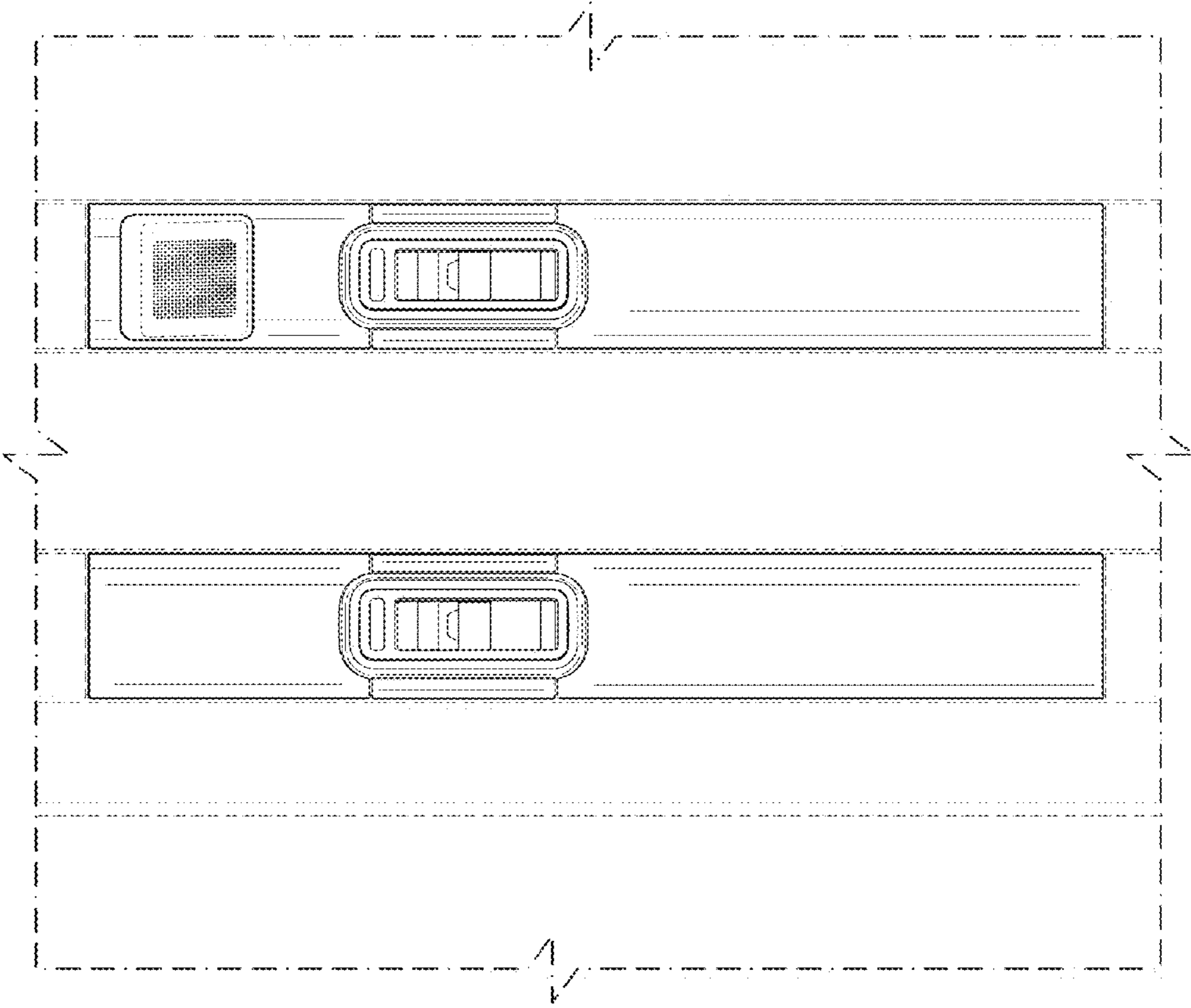

FIG. 2