

US00D762157S

(12) **United States Design Patent**
Faure et al.

(10) **Patent No.:** **US D762,157 S**
(45) **Date of Patent:** **** Jul. 26, 2016**

(54) **AIRPLANE**
(71) Applicant: **Airbus Defence and Space SAS**, Les Mureaux (FR)
(72) Inventors: **Benjamin Faure**, Saint André de Cubzac (FR); **Angélique Santerre**, Listrac-Médoc (FR); **Jean Philippe Dutheil**, Martignas-sur-Jalle (FR); **Christophe Chavagnac**, Paris (FR); **Eugénio Ferreira**, Paris (FR); **Thierry Pichard**, Suresnes (FR)
(73) Assignee: **AIRBUS DEFENCE AND SPACE SAS**, Les Mureaux (FR)

(**) Term: **14 Years**
(21) Appl. No.: **29/498,517**
(22) Filed: **Aug. 5, 2014**

(30) **Foreign Application Priority Data**
Feb. 6, 2014 (EM) 002399592-0002
(51) **LOC (10) Cl.** **12-07**
(52) **U.S. Cl.**
USPC **D12/342**
(58) **Field of Classification Search**
USPC D12/319, 322, 323, 326, 327, 328, 329, D12/330, 339, 341, 342, 343, 344, 345; D21/436, 438, 439, 440, 441, 446, 447, D21/448, 449, 450, 453
CPC B64C 39/00; B64C 30/00; B64C 29/00
See application file for complete search history.

(56) **References Cited**
U.S. PATENT DOCUMENTS
D231,605 S * 5/1974 Frajola D12/337
D259,411 S * 6/1981 Miller et al. D12/341

D326,842 S * 6/1992 Buchsel et al. D12/319
D426,804 S * 6/2000 Birrenbach D12/319
D491,875 S * 6/2004 Eatkins et al. D12/319
D499,688 S * 12/2004 Atkinson et al. D12/319
D500,281 S * 12/2004 Aruga et al. D12/319
D515,012 S * 2/2006 Eatkins et al. D12/319
D515,013 S * 2/2006 Eatkins et al. D12/319
D516,995 S * 3/2006 Eatkins et al. D12/319
D517,467 S * 3/2006 Vigneron et al. D12/319
D529,857 S * 10/2006 Eakins et al. D12/319

(Continued)

Primary Examiner — Robert M Spear
Assistant Examiner — Marissa J Cash
(74) *Attorney, Agent, or Firm* — Pearne & Gordon LLP

(57) **CLAIM**
We claim the ornamental design for an airplane, as shown and described.

DESCRIPTION

FIG. 1 is a rear perspective view of the airplane of the new design, from beneath the airplane.
FIG. 2 is a front perspective view of the airplane, from beneath.
FIG. 3 is a front view of the airplane.
FIG. 4 is a rear view of the airplane.
FIG. 5 is a top view of the airplane.
FIG. 6 is a bottom view of the airplane.
FIG. 7 is a left-side view of the airplane; and,
FIG. 8 is a front perspective view of the airplane and its rocket payload, after that payload has been separated from the airplane, for example via launching the rocket payload.
FIGS. 1-8 illustrate different views of the airplane of the new design, which has left-to-right mirror-image symmetry and in certain embodiments has a rocket payload suspended from beneath the fuselage of the airplane.
The broken lines shown on the drawings illustrate portions of the airplane that form no part of the claimed design.

1 Claim, 7 Drawing Sheets

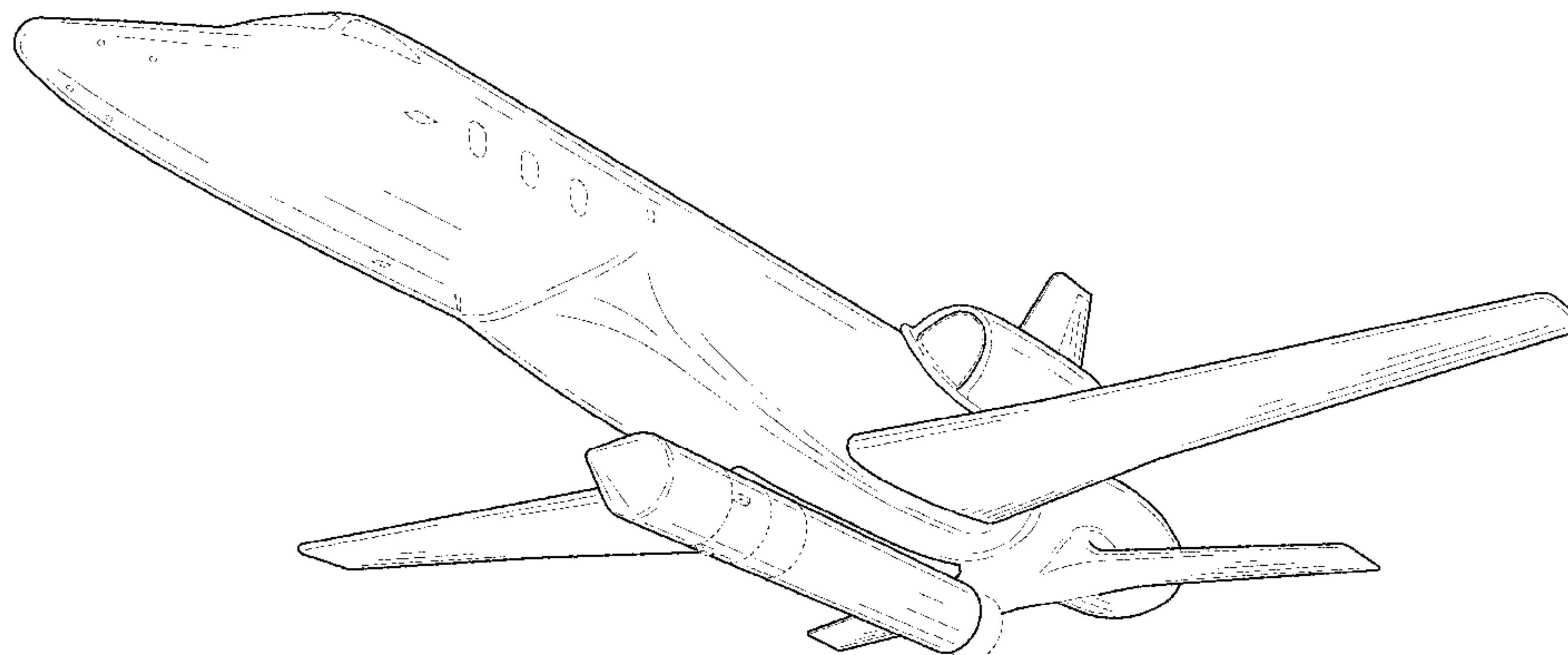

(56)

References Cited

U.S. PATENT DOCUMENTS

D530,658 S *	10/2006	Vigneron et al.	D12/319	D619,076 S *	7/2010	Guering	D12/343
D531,954 S *	11/2006	Eakins et al.	D12/319	D624,479 S *	9/2010	Guering	D12/343
D537,029 S *	2/2007	Eakins et al.	D12/319	D624,480 S *	9/2010	Guering	D12/343
D576,938 S *	9/2008	Moon	D12/343	D629,349 S *	12/2010	Hwang	D12/319
D589,867 S *	4/2009	Chesne et al.	D12/343	D634,696 S *	3/2011	Saint-Jalmes et al.	D12/345
D589,868 S *	4/2009	Matharan et al.	D12/343	D674,734 S *	1/2013	Fujino et al.	D12/345
D598,361 S *	8/2009	Beaunis et al.	D12/343	D702,622 S *	4/2014	Klimov et al.	D12/319
D612,792 S *	3/2010	Guering	D12/343	D731,949 S *	6/2015	Matsuo	D12/319
D617,724 S *	6/2010	Saint-Jalmes et al.	D12/343	D732,458 S *	6/2015	Dutertre	D12/319
				D733,029 S *	6/2015	Dutertre	D12/319
				D733,031 S *	6/2015	Horlin et al.	D12/345
				2010/0276545 A1 *	11/2010	Chavagnac et al.	244/158.9

* cited by examiner

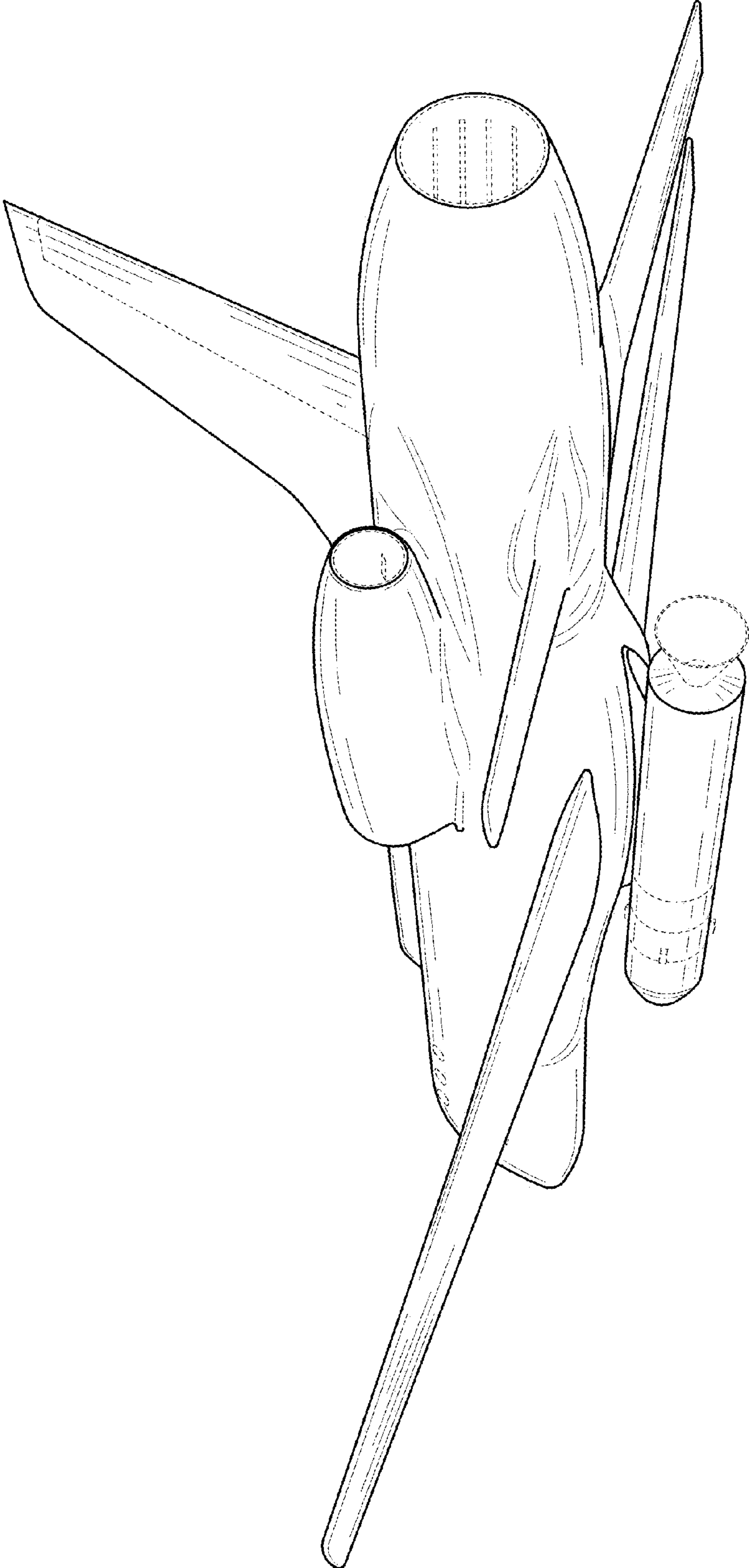

Fig. 1

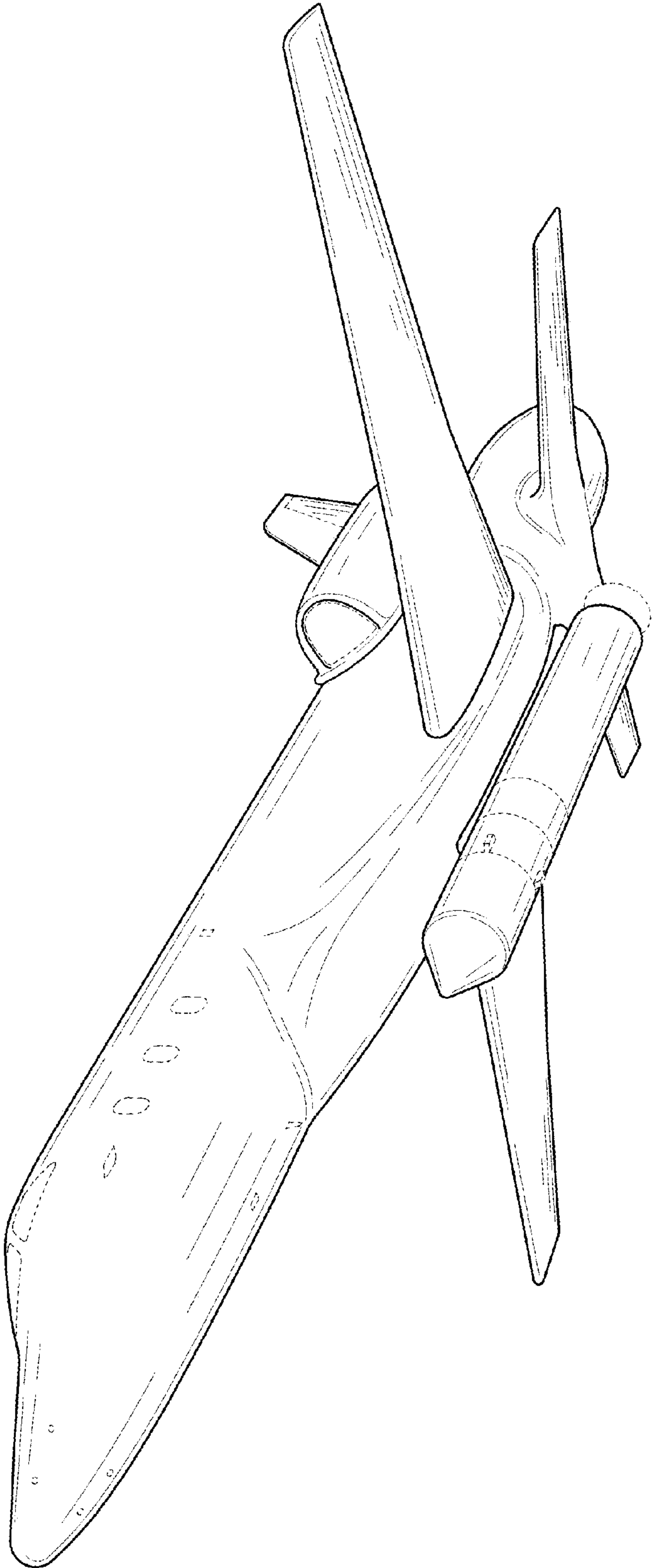

Fig. 2

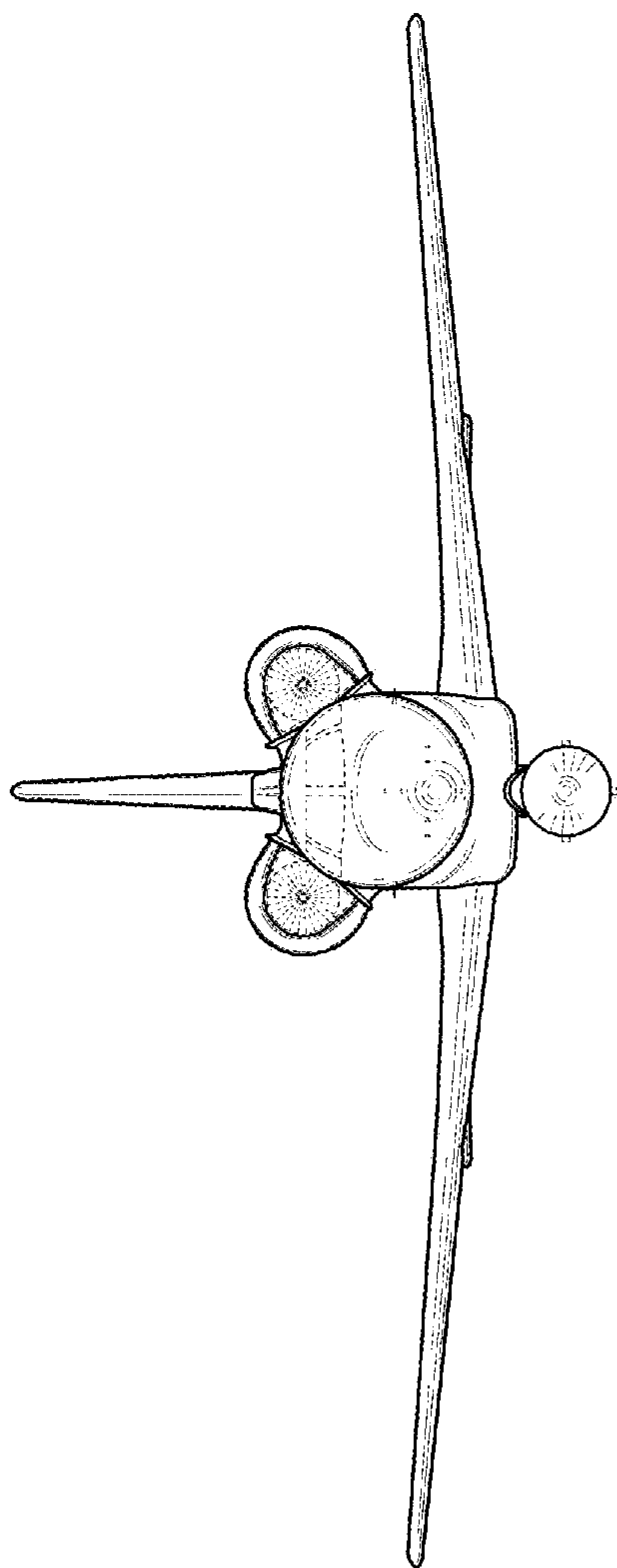

Fig. 3

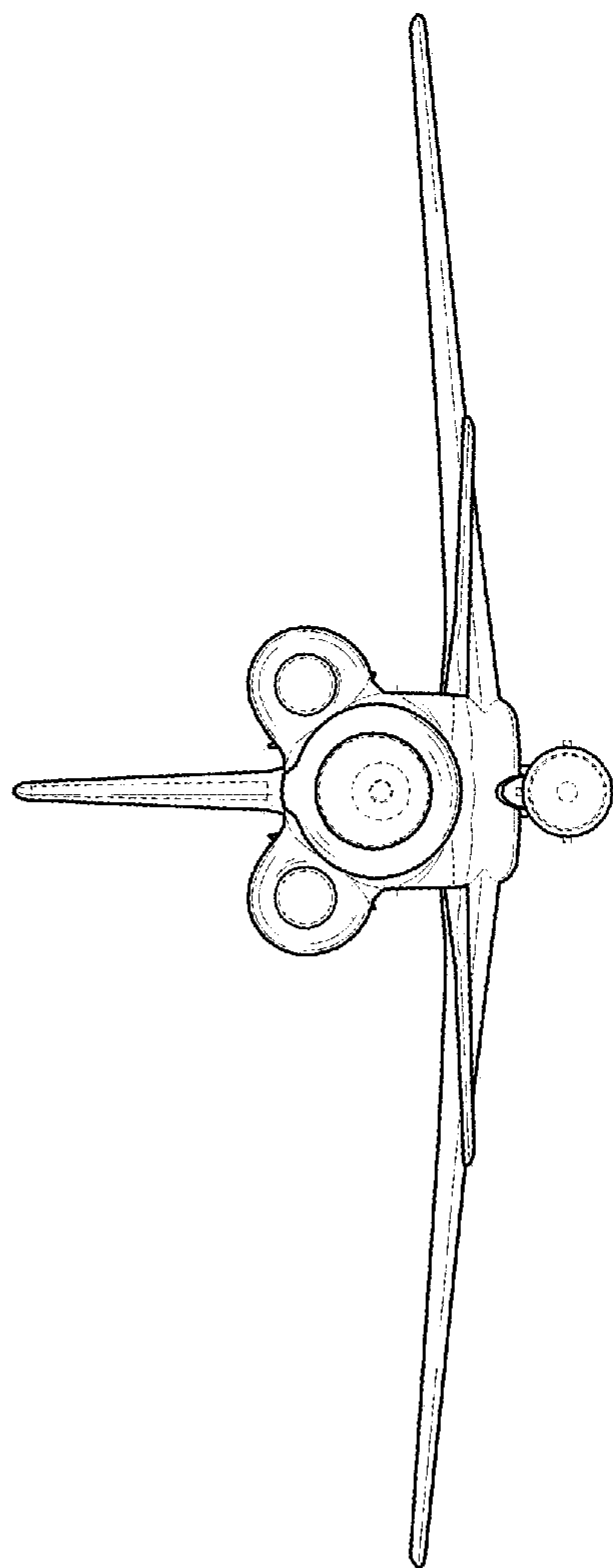

Fig. 4

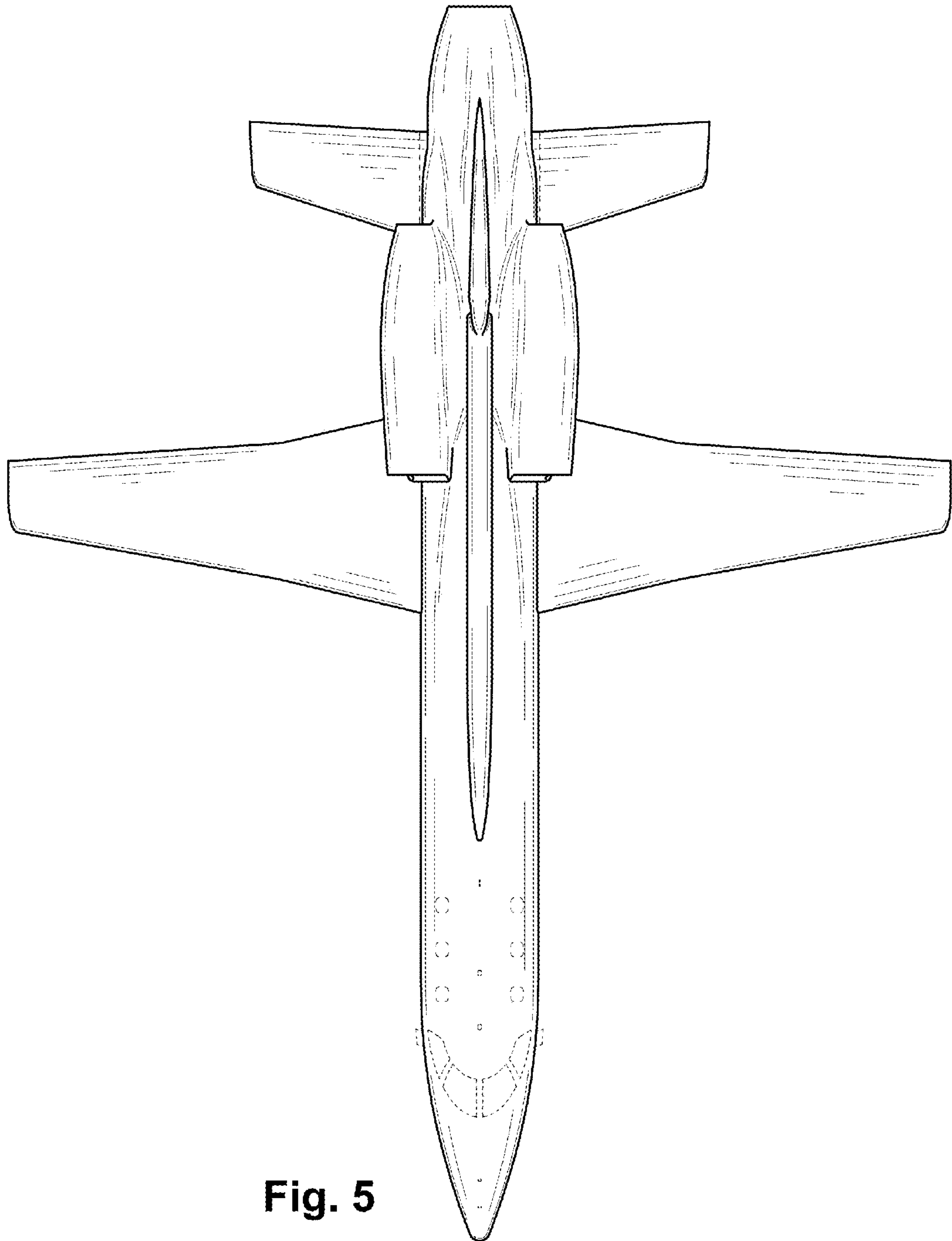

Fig. 5

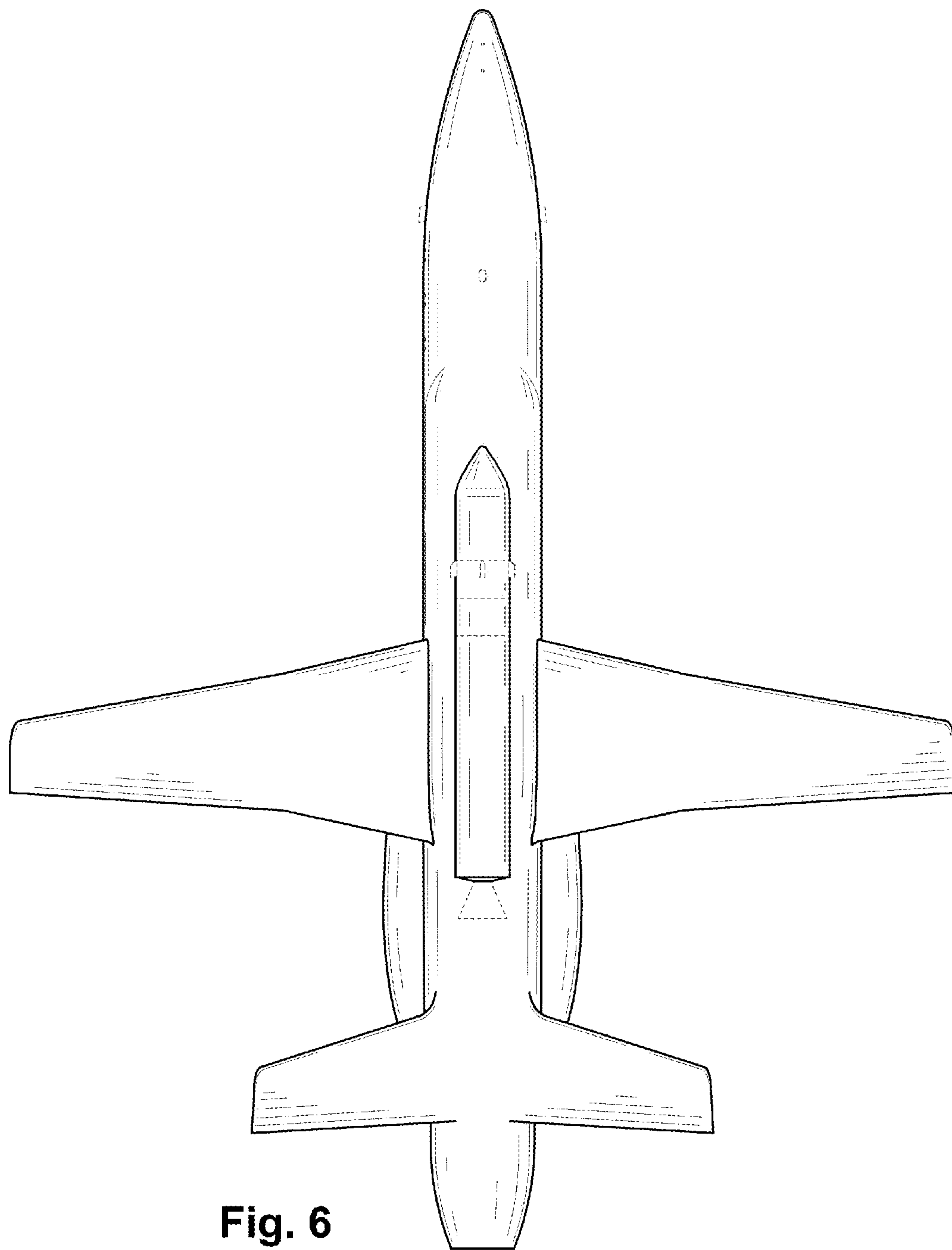

Fig. 6

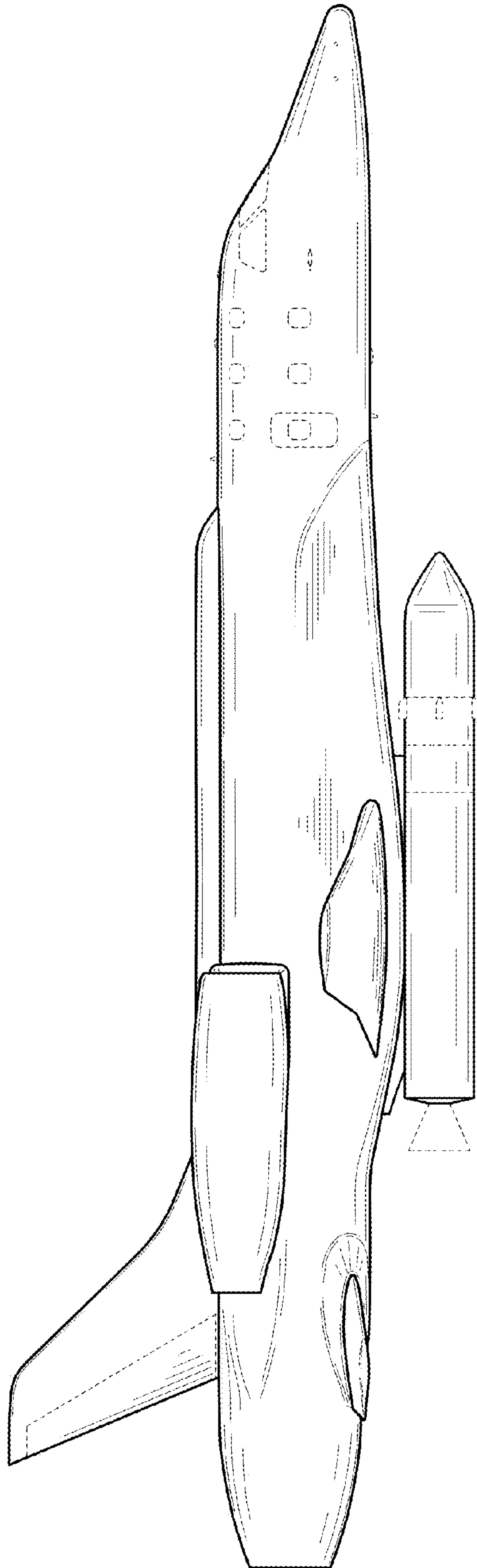

Fig. 7

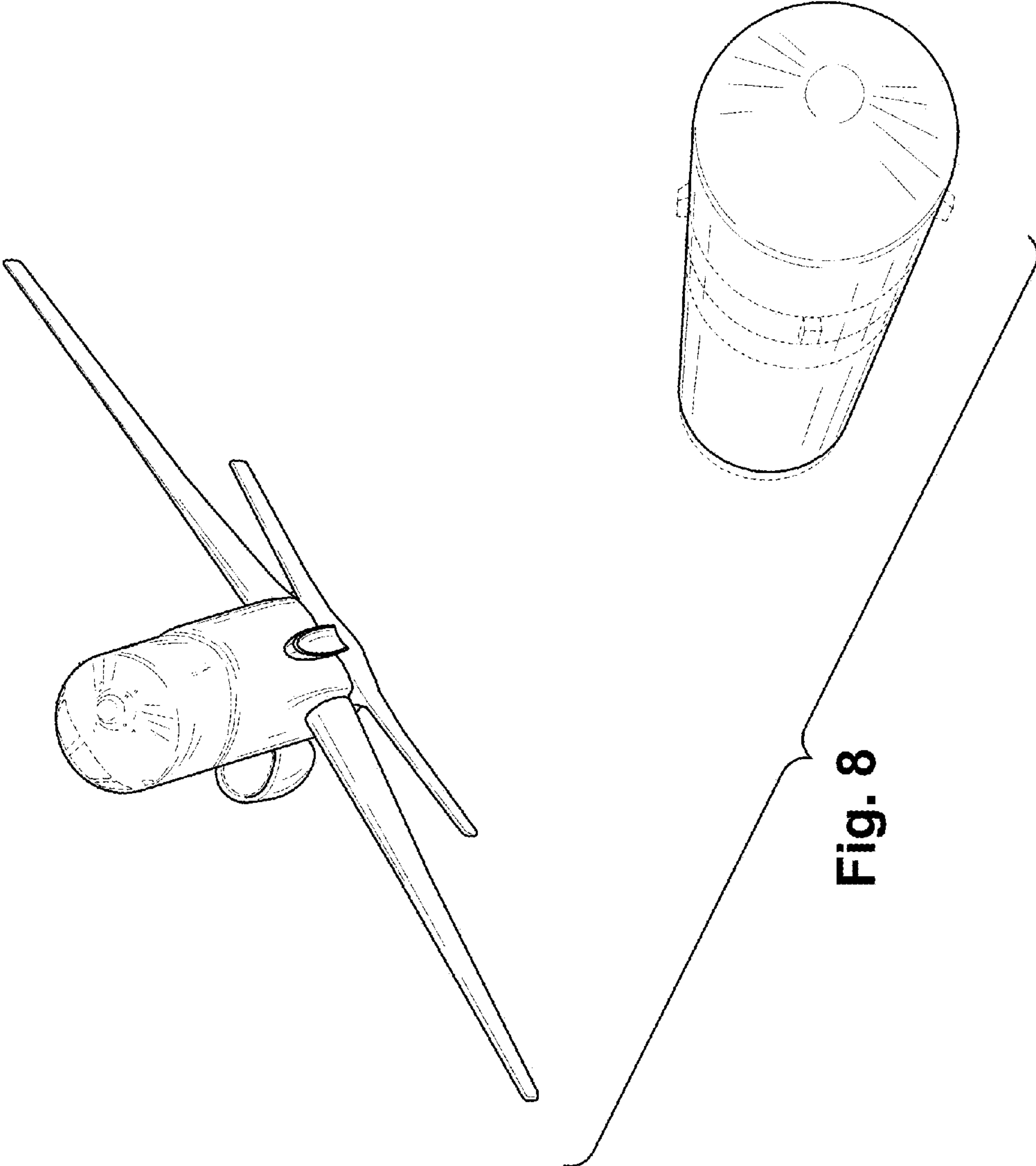

Fig. 8