

US00D762120S

(12) **United States Design Patent**  
**Valentine**

(10) **Patent No.:** **US D762,120 S**

(45) **Date of Patent:** **\*\* Jul. 26, 2016**

(54) **OIL CAN**

(71) Applicant: **Michael Valentine**, Centerville, MA  
(US)

(72) Inventor: **Michael Valentine**, Centerville, MA  
(US)

(\*\*) Term: **14 Years**

(21) Appl. No.: **29/520,147**

(22) Filed: **Mar. 11, 2015**

(51) **LOC (10) Cl.** ..... **09-01**

(52) **U.S. Cl.**  
USPC ..... **D9/525**; D9/575; D9/560

(58) **Field of Classification Search**  
USPC ..... D9/516, 523, 525, 530, 531, 533, 572,  
D9/575, 715, 719; D23/211.1  
CPC ..... B65D 85/00; B65D 1/02; B65D 1/12;  
B65D 1/18; B65D 1/20; B65D 21/0237;  
F16N 3/00; F16N 3/02; F16N 3/04  
See application file for complete search history.

(56) **References Cited**

U.S. PATENT DOCUMENTS

- 4,583,668 A \* 4/1986 Maynard, Jr. .... B65D 25/48  
141/367
- 4,901,878 A \* 2/1990 Humphries ..... B65D 1/14  
215/383
- D322,561 S \* 12/1991 Girouard ..... D9/524
- D328,431 S \* 8/1992 Skidmore ..... D9/417
- D376,664 S \* 12/1996 Petruzzi ..... D26/47

- 5,647,516 A \* 7/1997 Young ..... B65D 25/465  
222/529
- 5,934,522 A \* 8/1999 Canela ..... B65D 25/44  
141/337
- D416,803 S \* 11/1999 Voight ..... D9/523
- D439,519 S \* 3/2001 Ruble ..... D9/523
- D499,647 S \* 12/2004 Wills ..... D9/447
- D508,855 S \* 8/2005 Hasler ..... D9/523
- D548,094 S \* 8/2007 Salas ..... D9/524
- D571,216 S \* 6/2008 Christian ..... D9/523
- D586,221 S \* 2/2009 Shaikh ..... D9/523
- 7,624,899 B1 \* 12/2009 Barksdale ..... B65D 51/18  
215/43
- D661,592 S \* 6/2012 McIntire ..... D9/523
- 9,090,442 B2 \* 7/2015 Abell ..... B67D 7/005

\* cited by examiner

*Primary Examiner* — Ian Simmons

*Assistant Examiner* — Keith Frank

(74) *Attorney, Agent, or Firm* — Gary E. Lambert; David J. Connaughton, Jr.

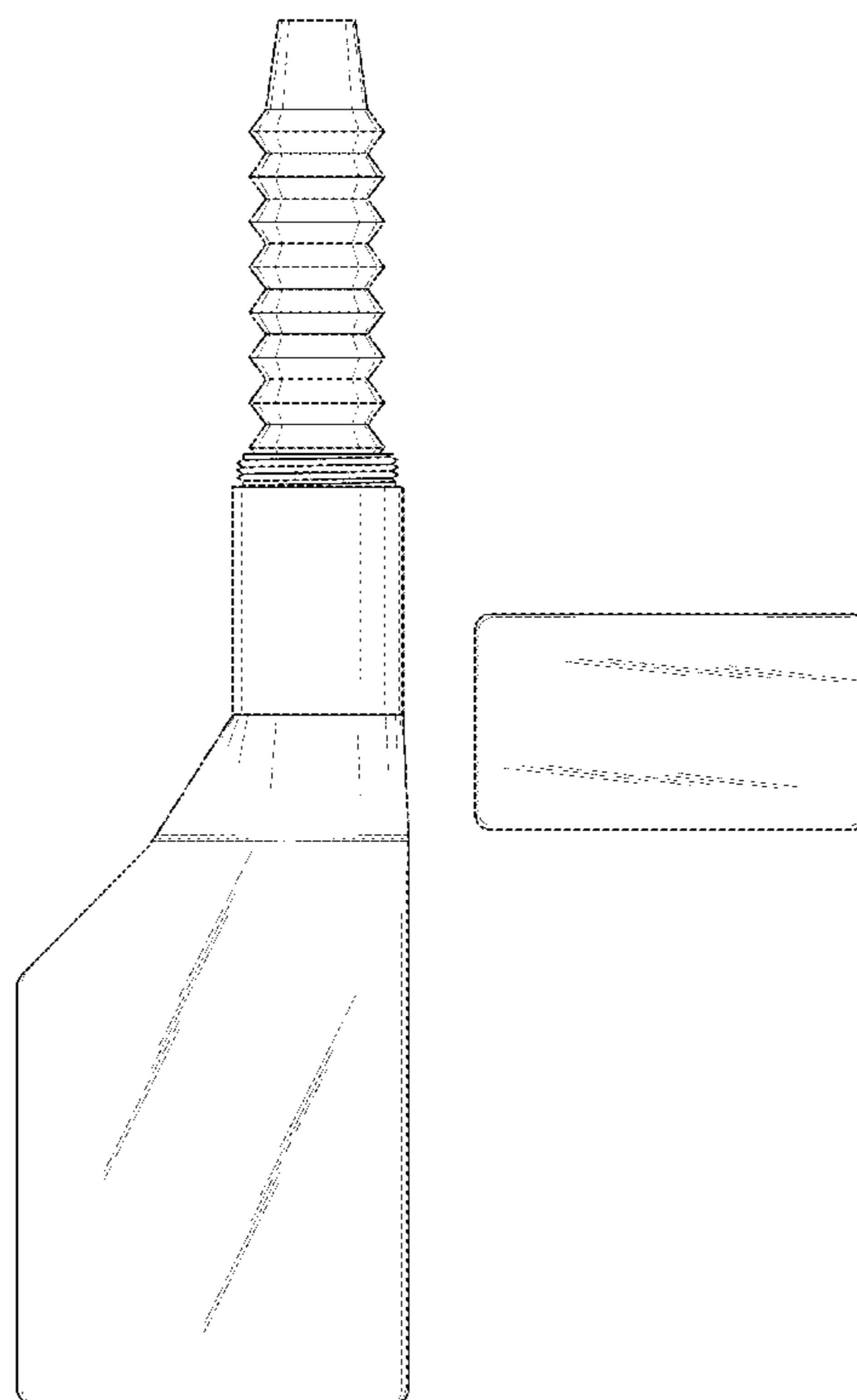
(57) **CLAIM**

The ornamental design for an oil can, as shown and described.

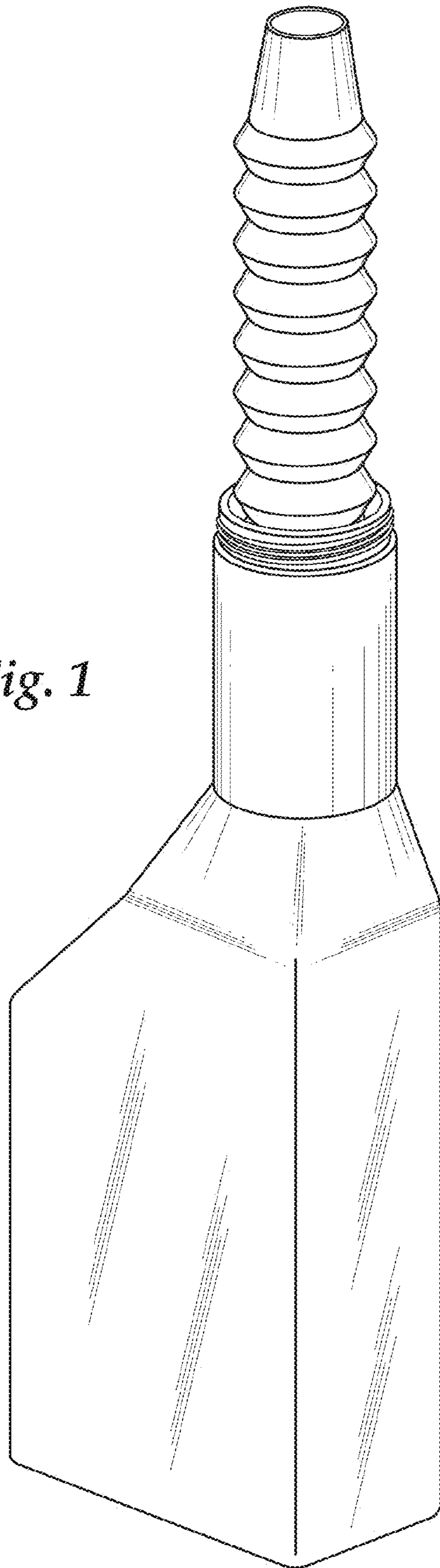
**DESCRIPTION**

FIG. 1 is a front perspective view of the oil can showing my new design;  
 FIG. 2 is a front elevation view thereof;  
 FIG. 3 is a left side elevation view thereof;  
 FIG. 4 is a right side elevation view thereof;  
 FIG. 5 is a top plan view thereof; and,  
 FIG. 6 is a bottom plan view thereof.

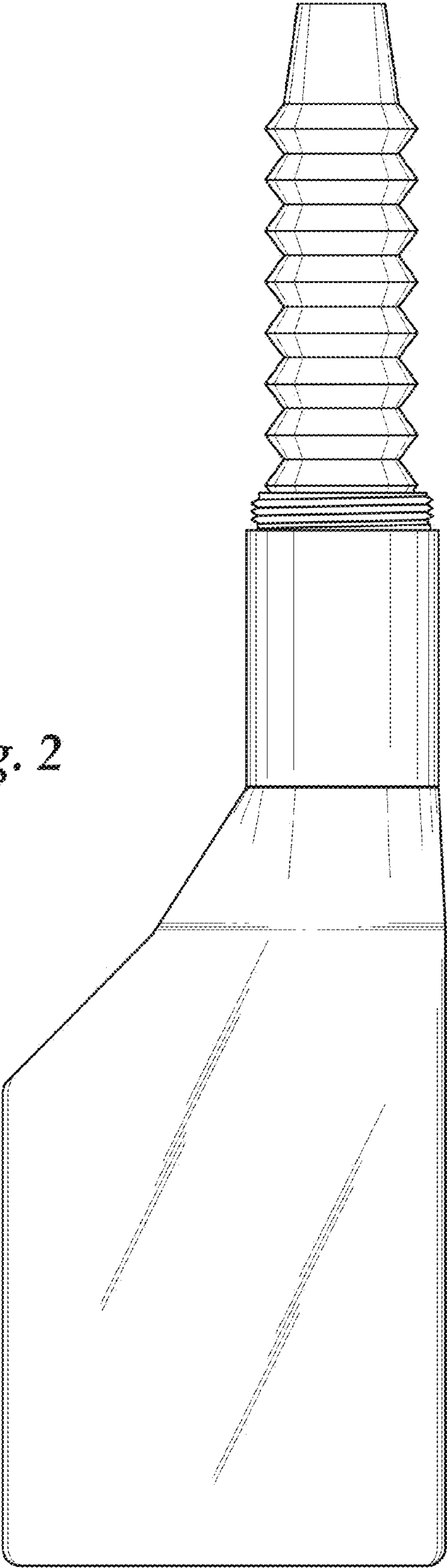
**1 Claim, 4 Drawing Sheets**

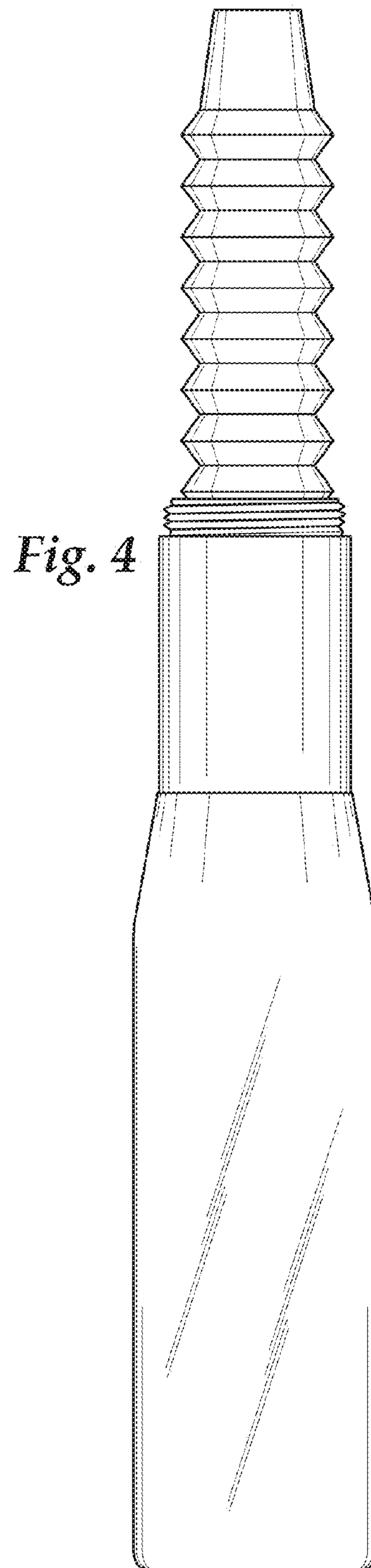
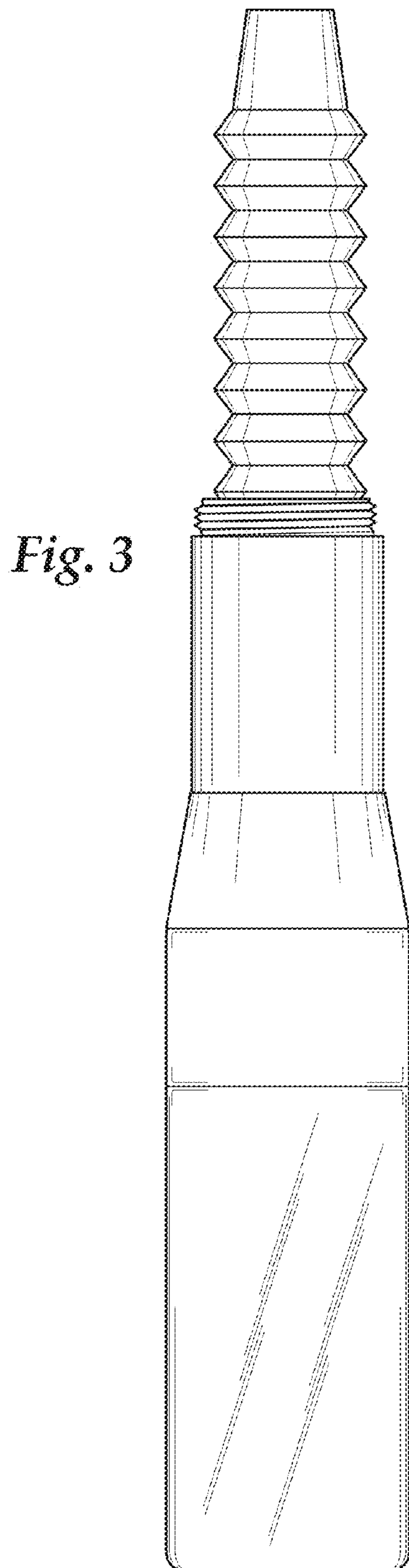


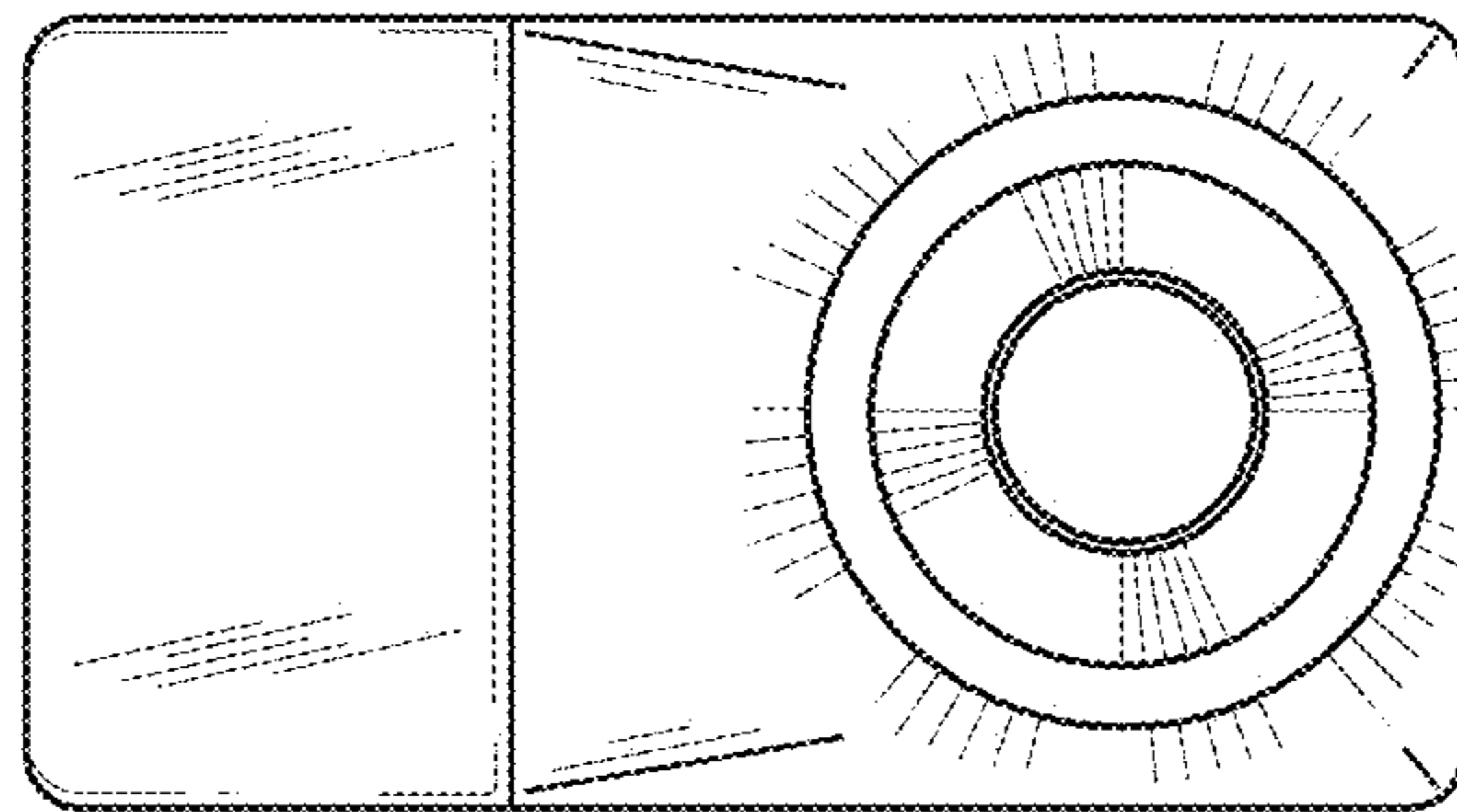
*Fig. 1*



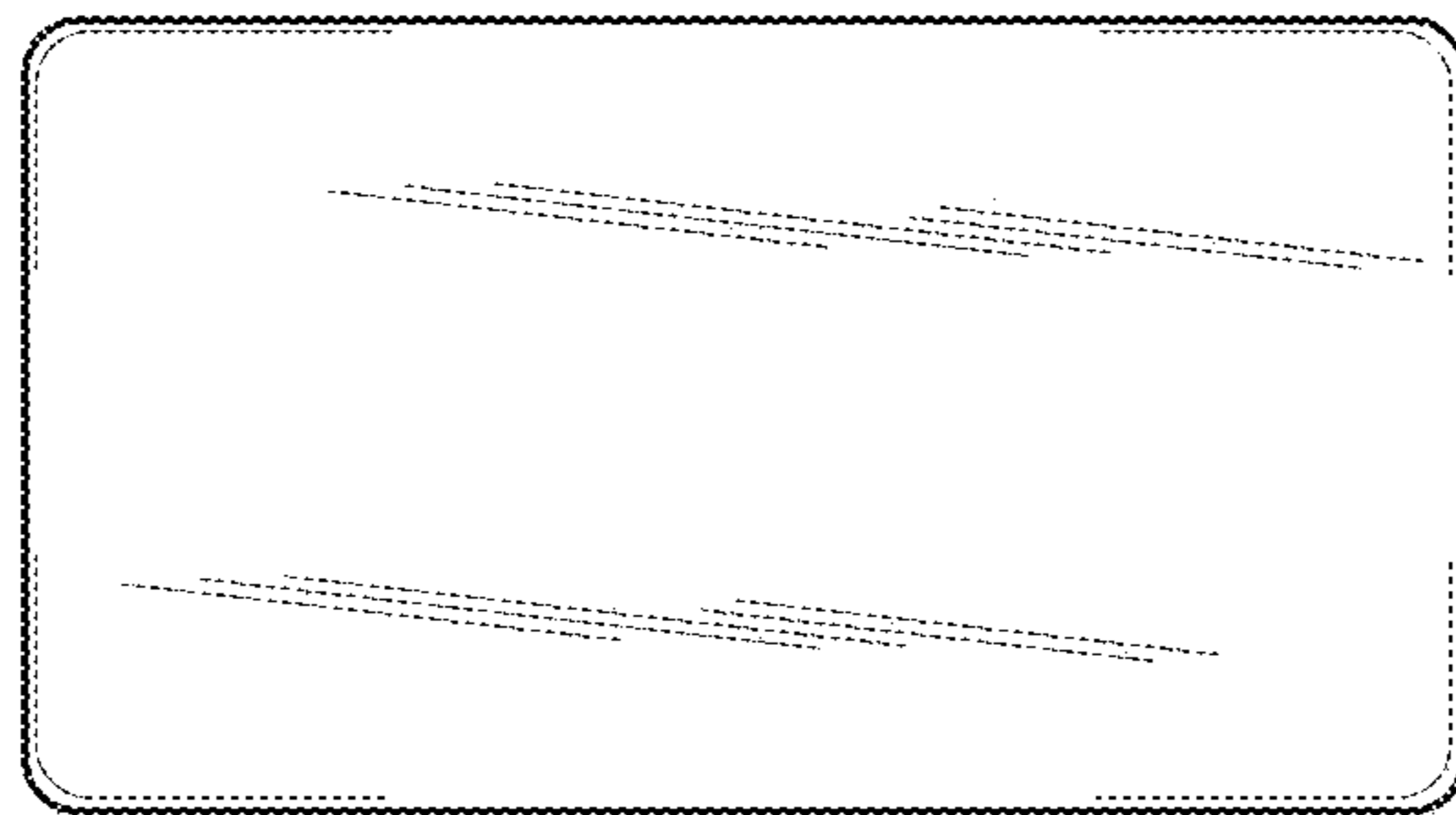
*Fig. 2*







*Fig. 5*



*Fig. 6*