



US00D762085S

(12) **United States Design Patent**
McDonald et al.

(10) **Patent No.:** **US D762,085 S**
(45) **Date of Patent:** **** Jul. 26, 2016**

- (54) **PORTION OF A WATER PITCHER LID**
- (71) Applicant: **Brita LP**, Oakland, CA (US)
- (72) Inventors: **Jonathan McDonald**, Danville, CA (US); **David Deacon**, Causeway Bay (HK)
- (73) Assignee: **Brita LP**, Oakland, CA (US)
- (**) Term: **15 Years**
- (21) Appl. No.: **29/536,100**
- (22) Filed: **Aug. 13, 2015**
- (51) **LOC (10) Cl.** **07-99**
- (52) **U.S. Cl.**
USPC **D7/392; D7/392.1; D7/400; D7/397**
- (58) **Field of Classification Search**
USPC D7/300.1, 510, 511, 598, 599, 600, 608, D7/515, 523, 312, 306, 300, 316-319, 400, D7/398, 397, 399, 401, 392.1, 392; 169/71; D9/680; D22/112; 102/486; D29/125, 126; 220/713, 715, 739; D23/209; D10/46.2; 210/264, 321.6; 62/457.3
CPC A47G 19/22; A47G 21/18; A47G 19/00; A47G 19/12; A47G 19/127; A62C 13/003; A47J 43/044; F25D 2303/0831; B01D 29/05; B01D 29/085; B01D 2201/4084; C02F 1/003
See application file for complete search history.

- (56) **References Cited**
U.S. PATENT DOCUMENTS
D340,382 S * 10/1993 Bannigan D7/400
5,503,740 A * 4/1996 Callaghan B01D 29/05
210/232
5,609,194 A * 3/1997 Link A47G 19/12
141/331
D386,944 S * 12/1997 Demore D23/209

5,800,707 A *	9/1998	Mehnert	C02F 1/003
				210/232
D415,922 S *	11/1999	Kawasaki	D7/317
D437,027 S *	1/2001	Flagler	D23/209
D459,941 S *	7/2002	Miller	D23/207
D520,597 S *	5/2006	Witte	D23/209
D558,516 S	1/2008	Bulala et al.		
D584,913 S *	1/2009	Green	D7/317
D585,231 S *	1/2009	Bulala	D7/317
D586,605 S *	2/2009	Ma	D7/317
D600,498 S *	9/2009	Ma	D7/397
D604,088 S *	11/2009	Bursztein	D7/317
D618,032 S	6/2010	Kulikov et al.		
D626,777 S *	11/2010	Bell	D7/317
D626,779 S *	11/2010	Bell	D7/317
D640,769 S	6/2011	Sheppard et al.		
D640,770 S	6/2011	Sheppard et al.		
D675,861 S *	2/2013	Gray	D7/317
D680,789 S *	4/2013	Bell	D7/317
D680,790 S *	4/2013	Bell	D7/317
D680,791 S *	4/2013	Bell	D7/317

(Continued)

Primary Examiner — Marianne Pandozzi
(74) *Attorney, Agent, or Firm* — Thomas C. Feix; Stacy H. Combs

(57) **CLAIM**
The ornamental design for a portion of a water pitcher lid, as shown and described.

DESCRIPTION

FIG. 1 is an exploded perspective view of a portion of a water pitcher lid and showing our new design; FIG. 2 is a front perspective view thereof; FIG. 3 is a top plan view of FIG. 2; FIG. 4 is bottom plan view of FIG. 2; FIG. 5 is a left side elevational view of FIG. 2; FIG. 6 is a right side elevational view of FIG. 2; FIG. 7 is back view of FIG. 2; and, FIG. 8 is a front view of FIG. 2. The broken lines in the drawing depict environmental subject matter only and form no part of the claimed design.

1 Claim, 3 Drawing Sheets

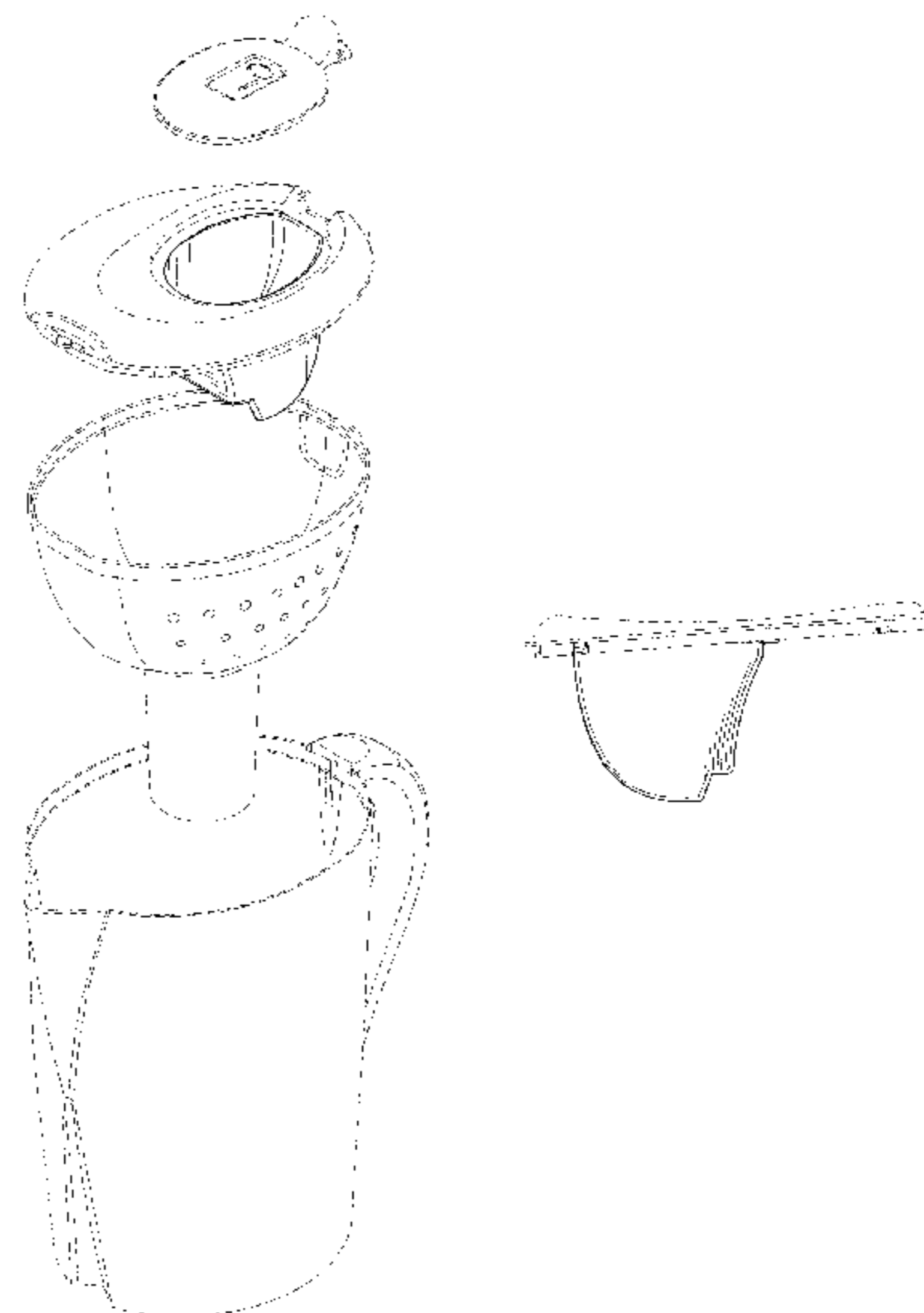

US D762,085 S

Page 2

(56)

References Cited

U.S. PATENT DOCUMENTS

D707,490 S *	6/2014	Hertaus	D7/397
9,090,483 B2 *	7/2015	Rajan	C02F 1/003
D753,954 S *	4/2016	Schreiber	D7/400
D688,095 S *	8/2013	DeMiglio	D7/400

* cited by examiner

FIG. 1

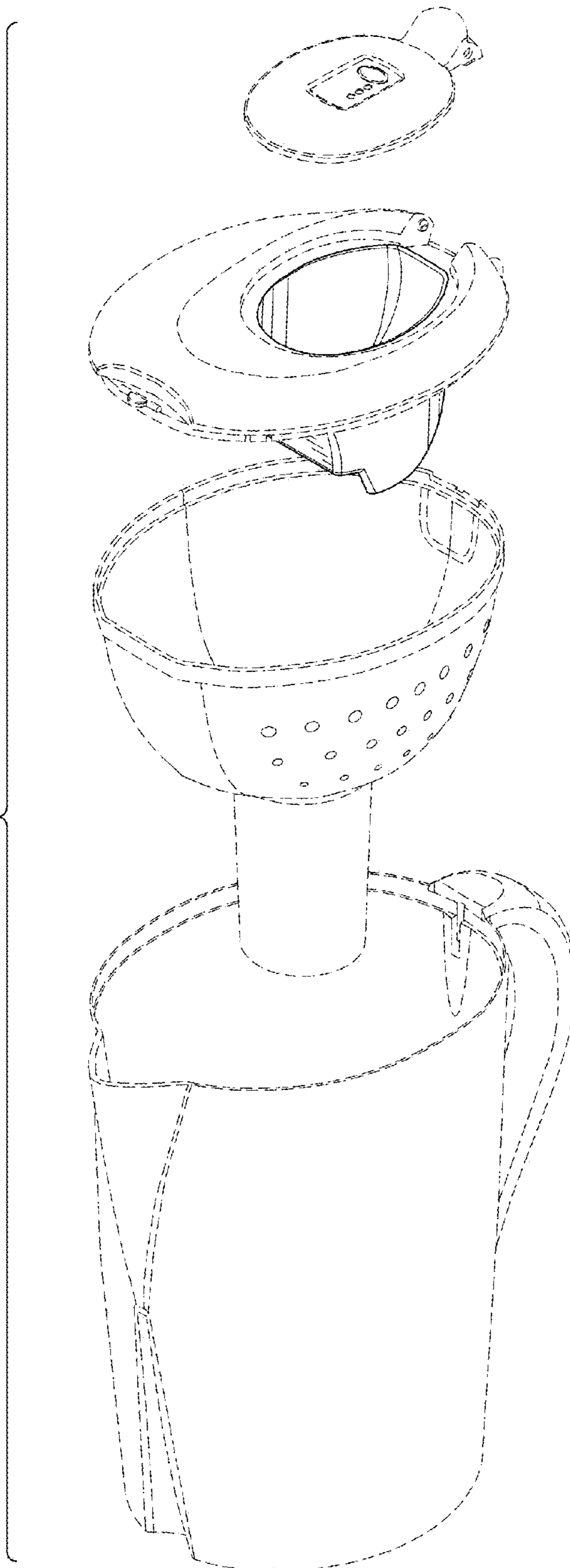

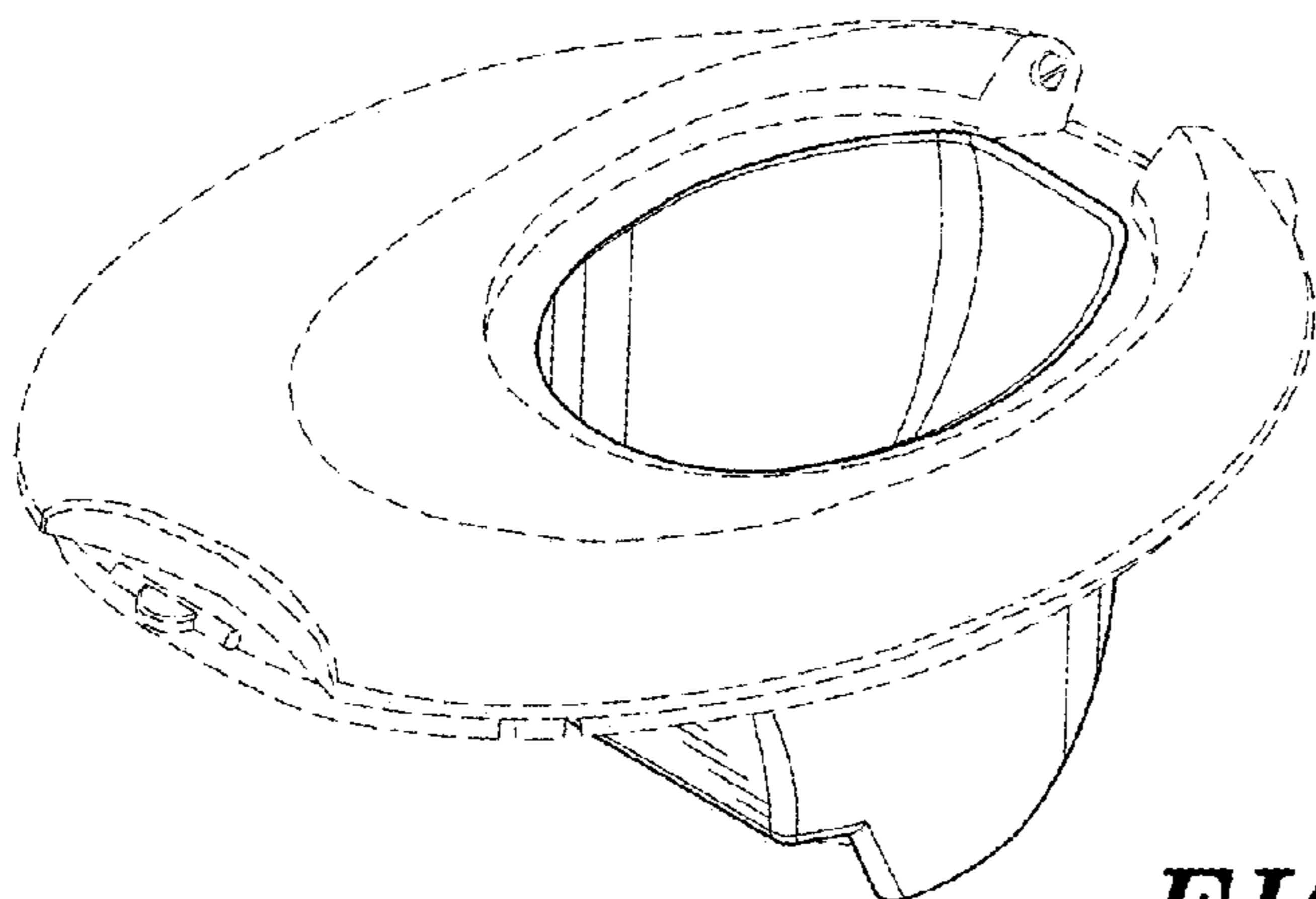

FIG. 2

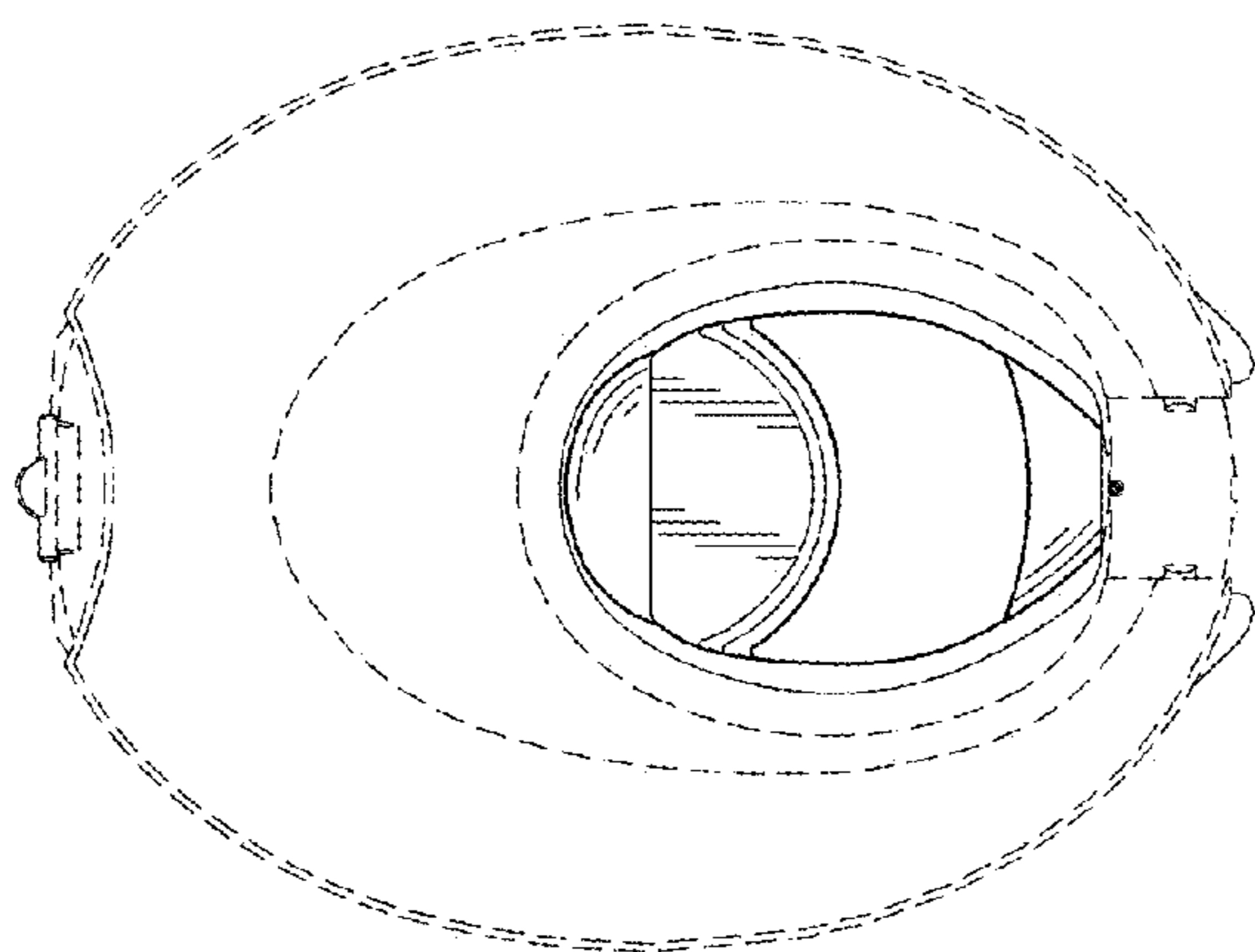

FIG. 3

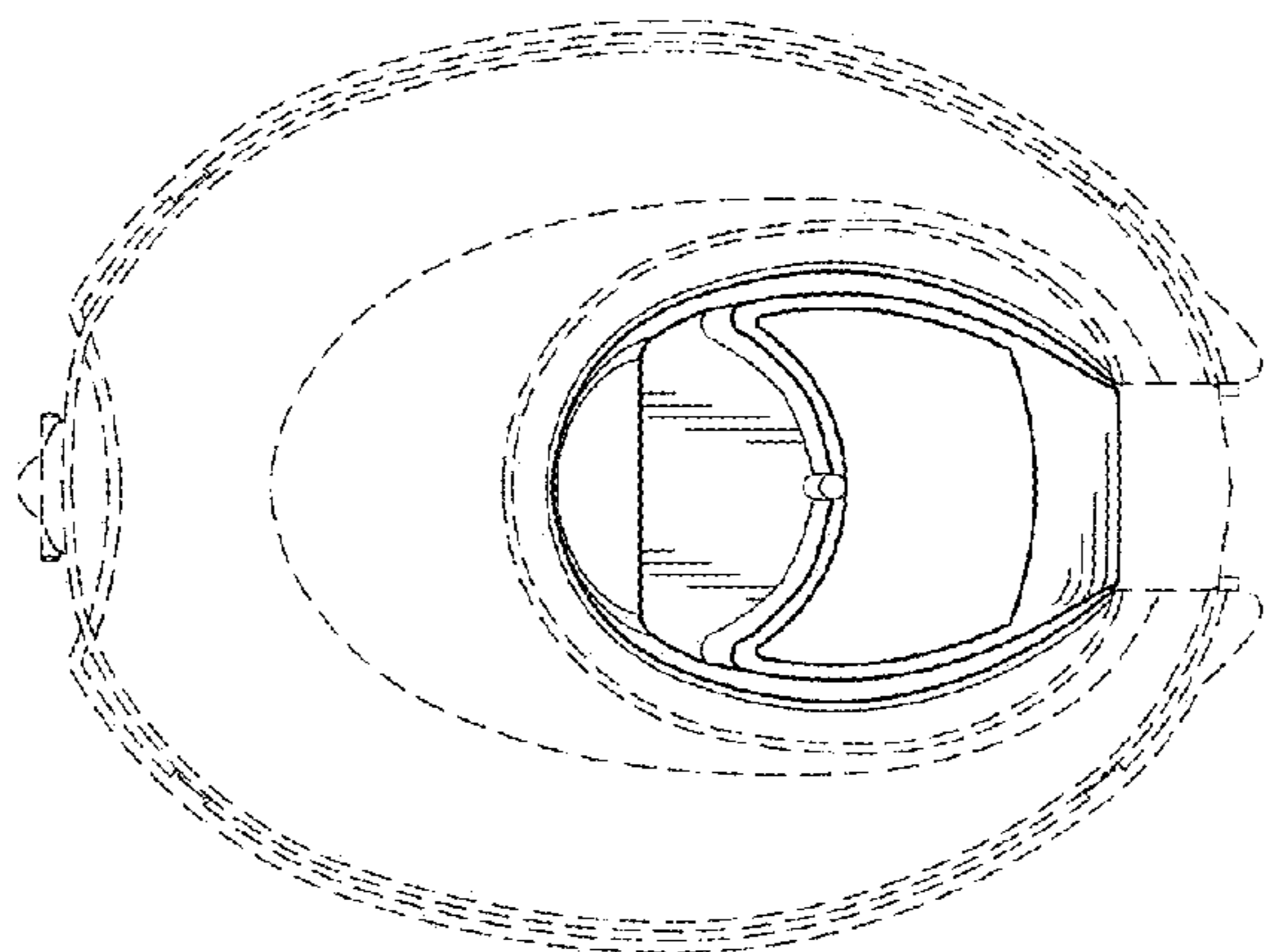

FIG. 4

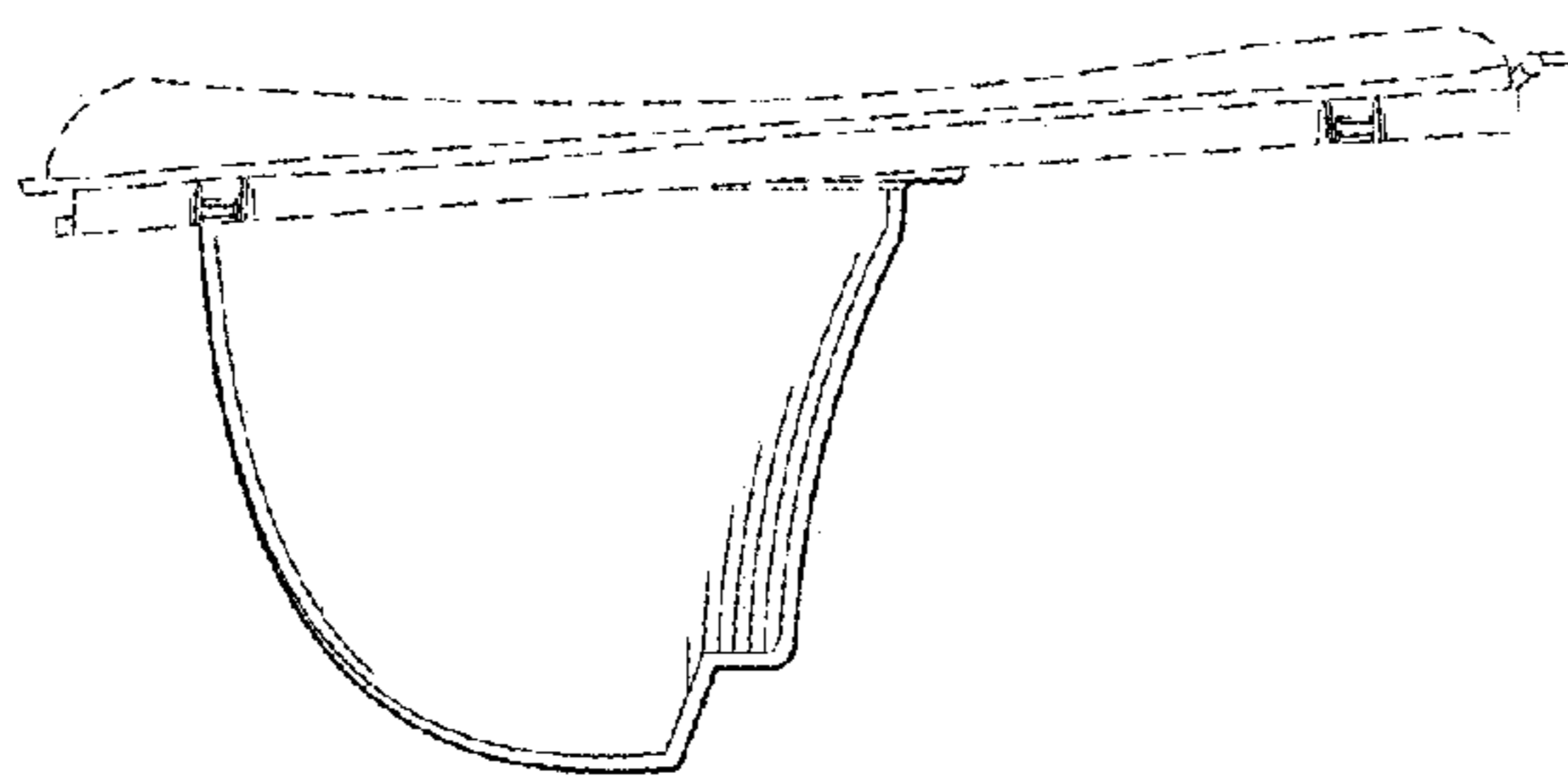

FIG. 5

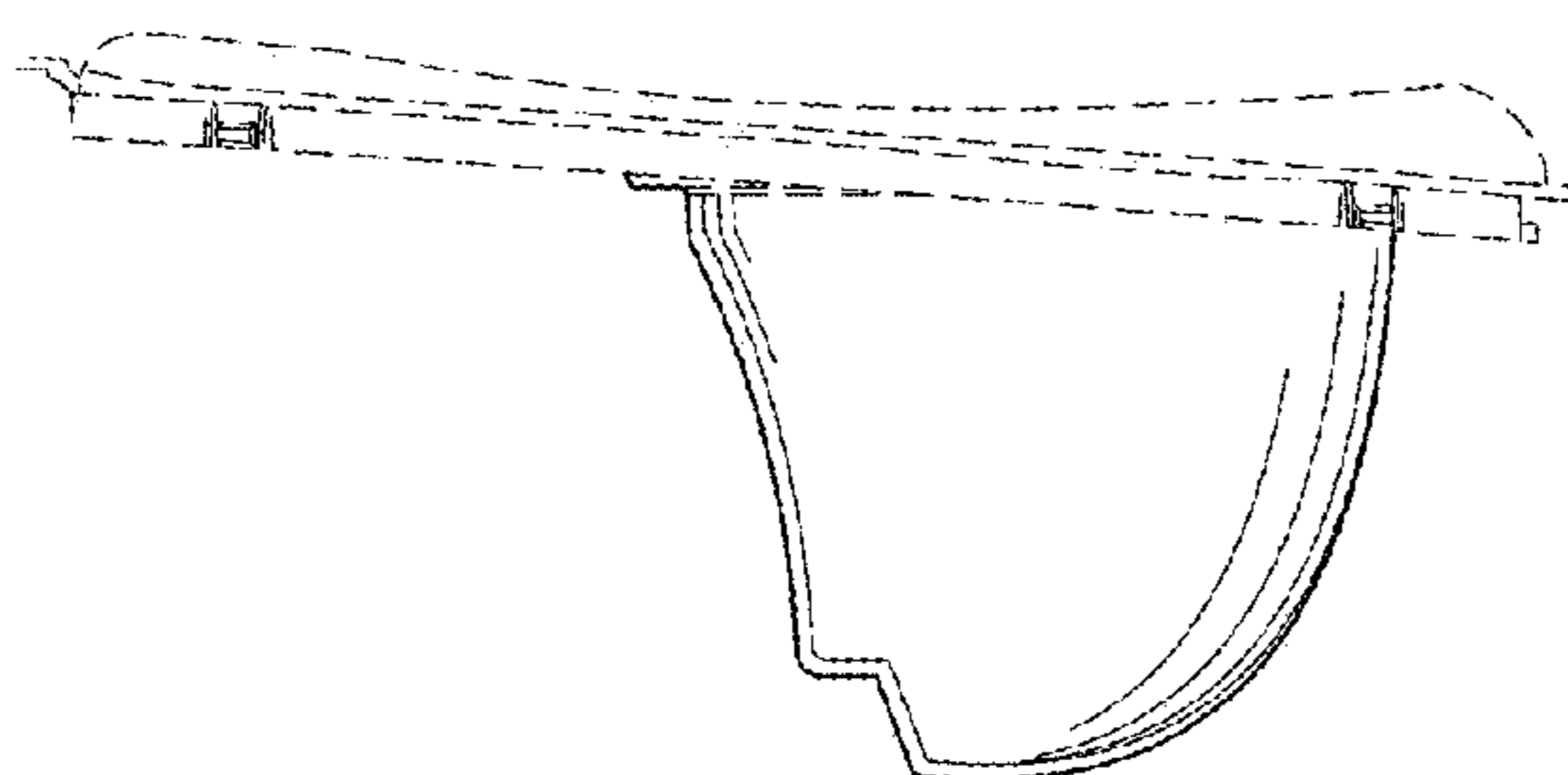

FIG. 6

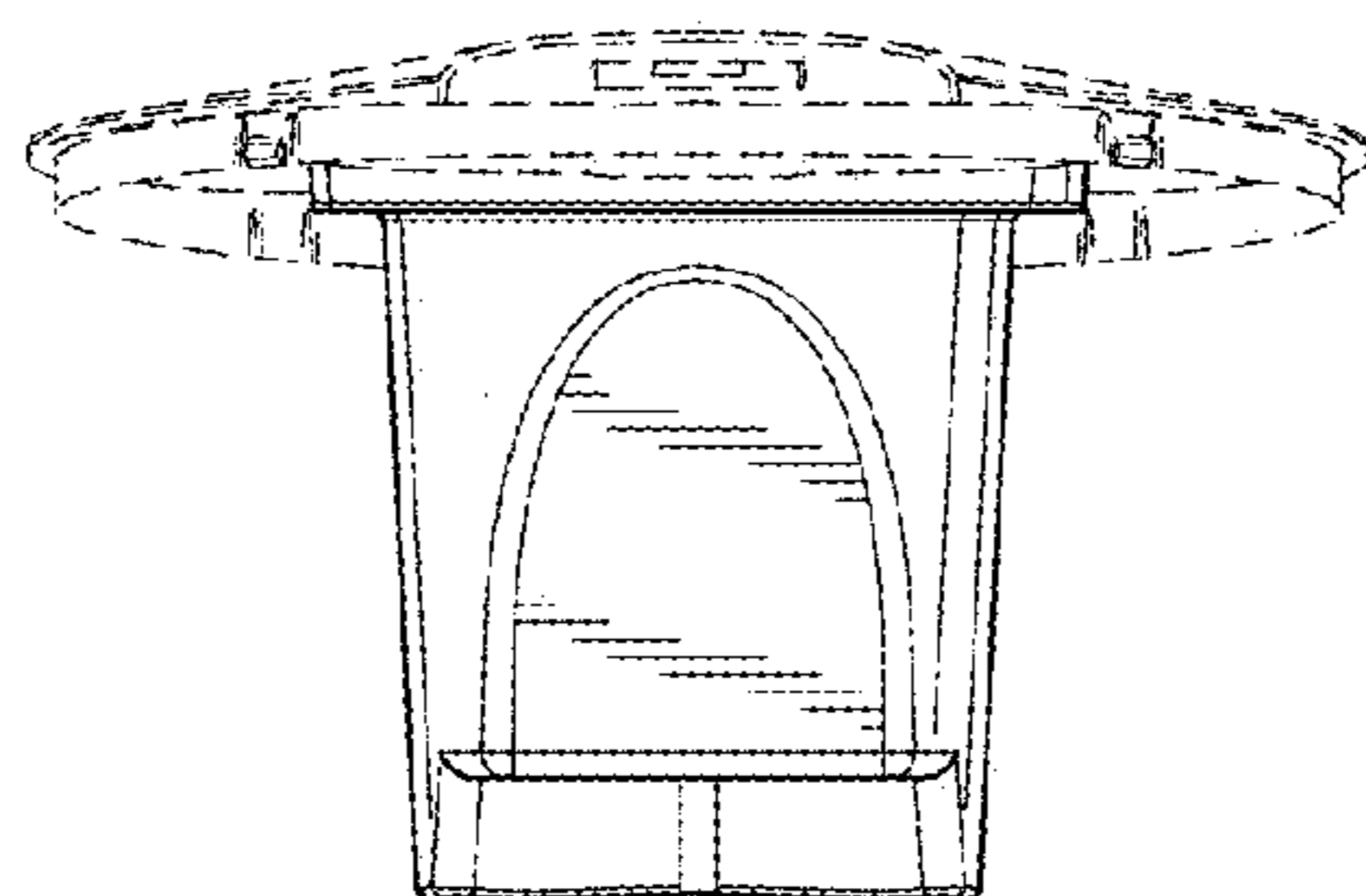

FIG. 7

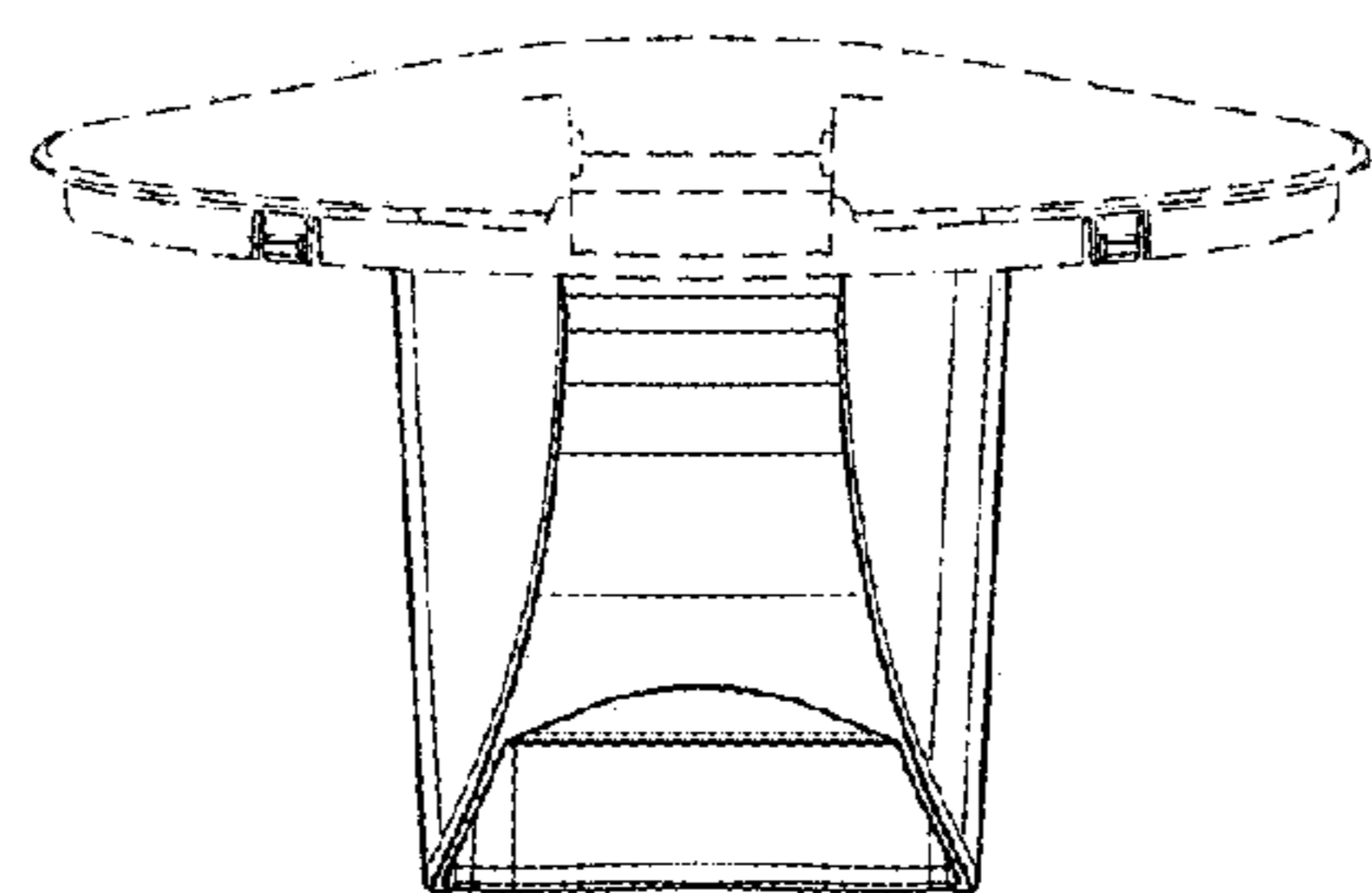

FIG. 8