



US00D761934S

(12) **United States Design Patent**
Branscomb et al.

(10) **Patent No.:** **US D761,934 S**
(45) **Date of Patent:** **** Jul. 19, 2016**

(54) FILTER CARTRIDGE	7,000,782 B2 * 2/2006 Walton B01D 29/15 210/232
(71) Applicant: 3M INNOVATIVE PROPERTIES COMPANY , St. Paul, MN (US)	D546,412 S * 7/2007 Kennedy D23/209 D547,821 S * 7/2007 Kennedy D23/207 D547,822 S * 7/2007 Kennedy D23/207 D547,823 S * 7/2007 Kennedy D23/207
(72) Inventors: Matt R. Branscomb , Lakeville, MN (US); Jeffrey M. Maki , Inver Grove Heights, MN (US); Jeremy A. Schmoll , Pine Island, MN (US); Jon P. Kragness , Farmington, MN (US)	7,481,928 B2 1/2009 Fritze 7,799,220 B2 9/2010 Fritze 8,177,976 B2 * 5/2012 Formica B01D 29/21 184/6.24 8,182,699 B2 5/2012 Fritze 8,354,024 B2 * 1/2013 Ihle 210/238 8,916,044 B2 * 12/2014 Rapin B01D 35/153 210/232
(73) Assignee: 3M Innovative Properties Company , St. Paul, MN (US)	9,067,154 B1 * 6/2015 Branscomb B01D 35/306 D750,739 S * 3/2016 Baird D23/209

(**) Term: **15 Years**

(21) Appl. No.: **29/527,417**

(22) Filed: **May 19, 2015**

(51) **LOC (10) Cl.** **23-01**

(52) **U.S. Cl.**
USPC **D23/209**

(58) **Field of Classification Search**
USPC D23/207, 209; D7/400; 210/232, 282,
210/244, 238, 493.2; 285/360, 361
CPC C02F 1/003; B01D 35/30; B01D 35/153;
B01D 35/157

See application file for complete search history.

(56) **References Cited**

U.S. PATENT DOCUMENTS

2,165,163 A * 7/1939 Waters F16L 37/113 285/361
2,170,010 A * 8/1939 Conner B21D 51/38 222/400.7
4,871,455 A * 10/1989 Terhune B01D 29/15 210/232
D472,299 S * 3/2003 Fritze D23/209

OTHER PUBLICATIONS

Branscomb, Design U.S. Appl. No. 29/527,411, entitled "Filter Cartridge", filed May 19, 2015.

* cited by examiner

Primary Examiner — Robin V Webster

(74) *Attorney, Agent, or Firm* — Scott A. Baum

(57) **CLAIM**

The ornamental design for a filter cartridge, as shown and described.

DESCRIPTION

FIG. 1 is a perspective view of the new design for a filter cartridge;

FIG. 2 is a front view thereof;

FIG. 3 is a side view thereof;

FIG. 4 is a top view thereof; and,

FIG. 5 is a bottom view thereof.

The broken lines in the Figures form no part of the claimed design.

1 Claim, 2 Drawing Sheets

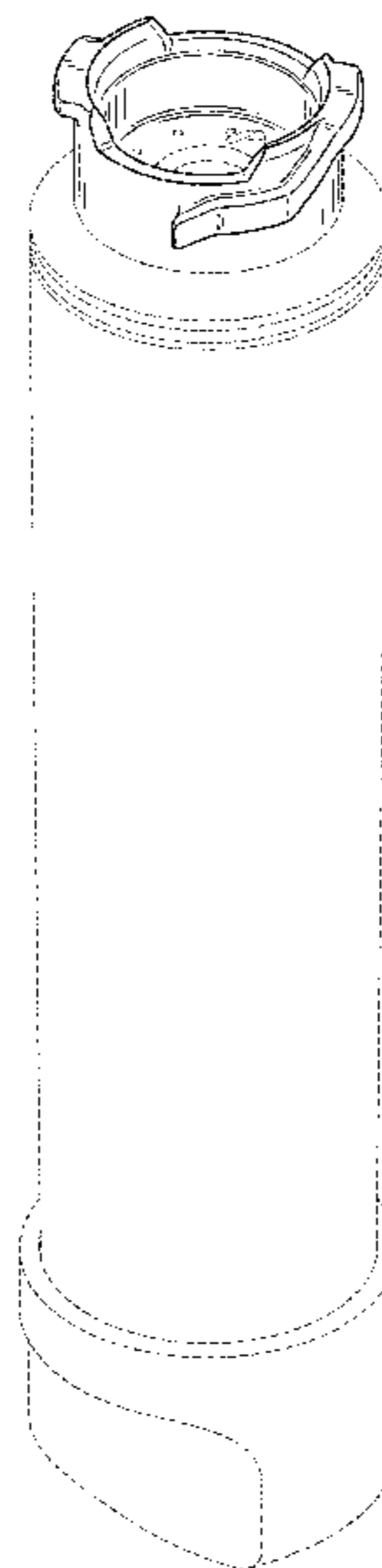

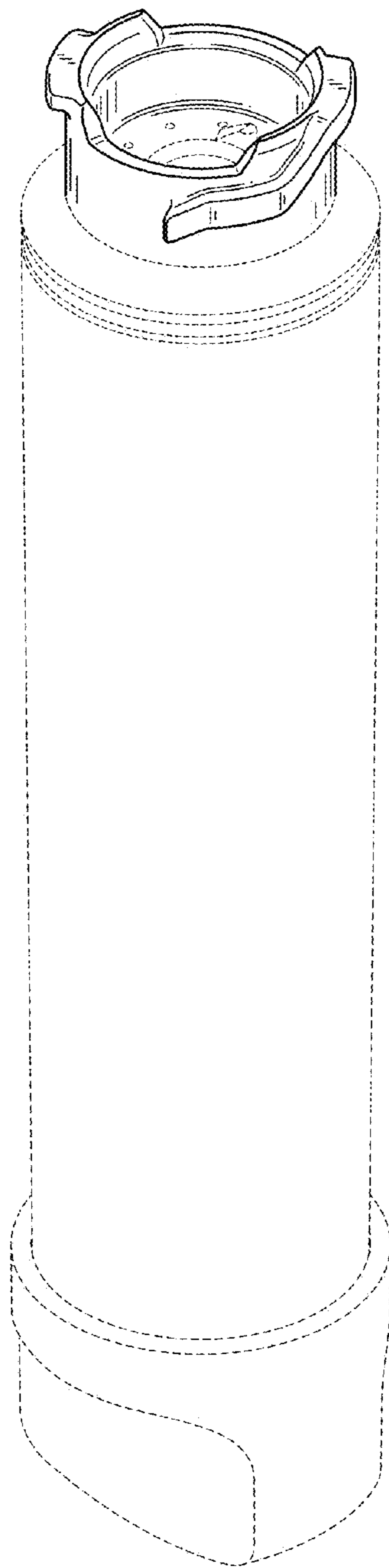

FIG. 1

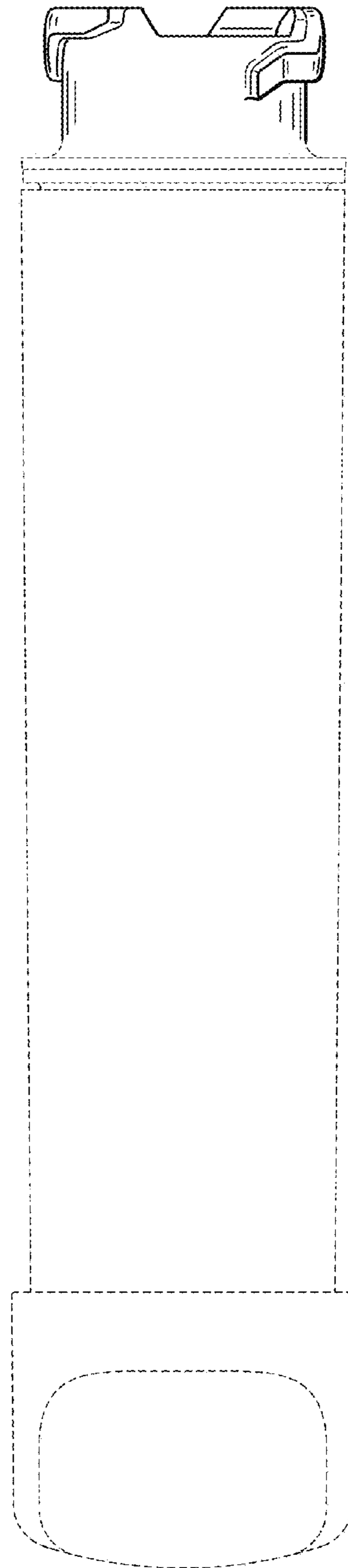

FIG. 2

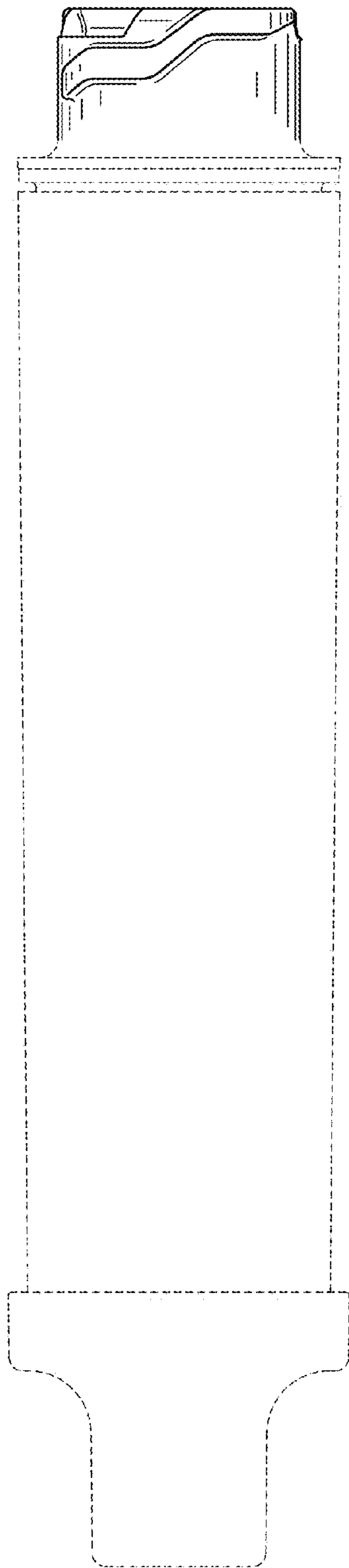

FIG. 3

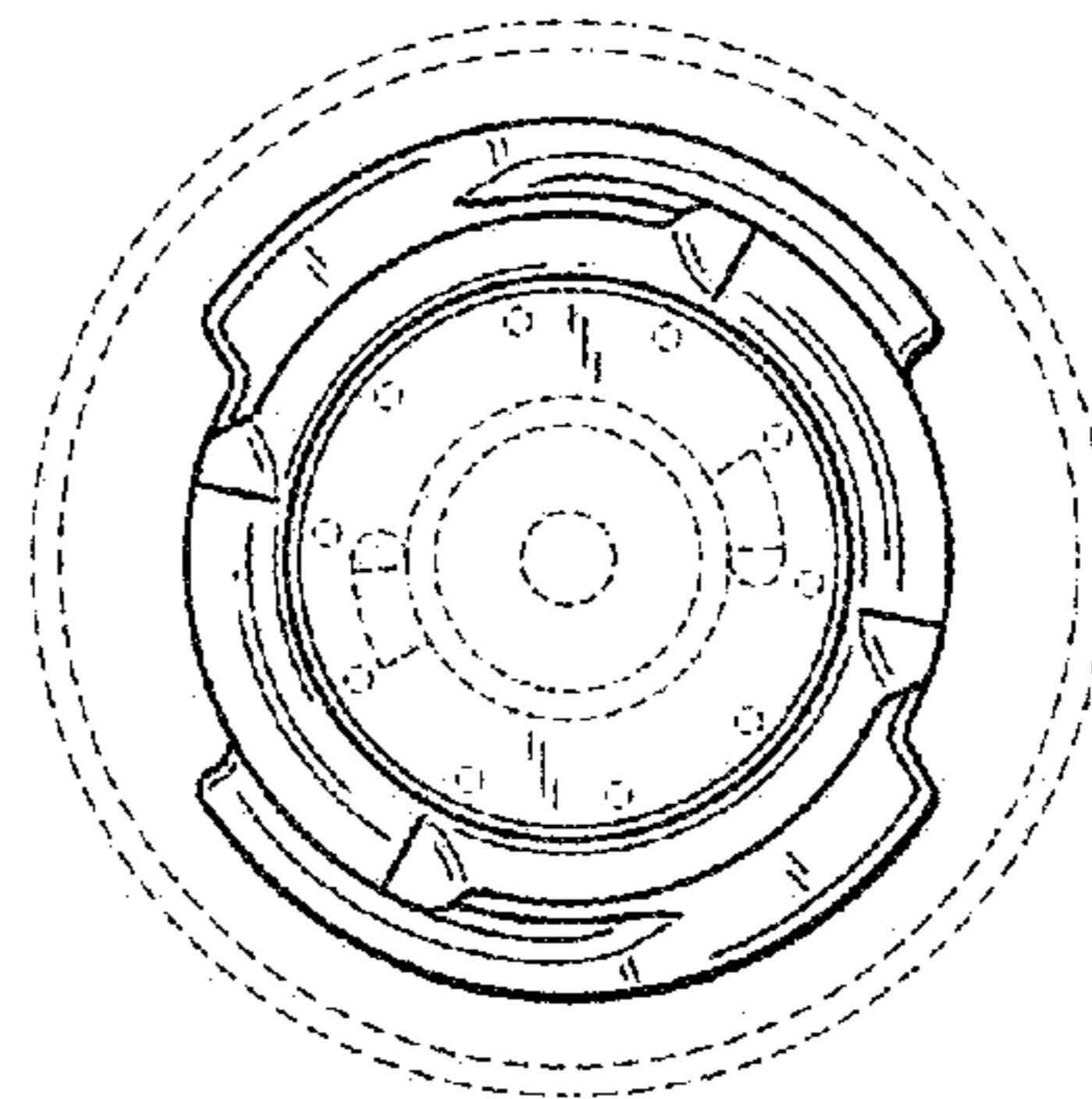

FIG. 4

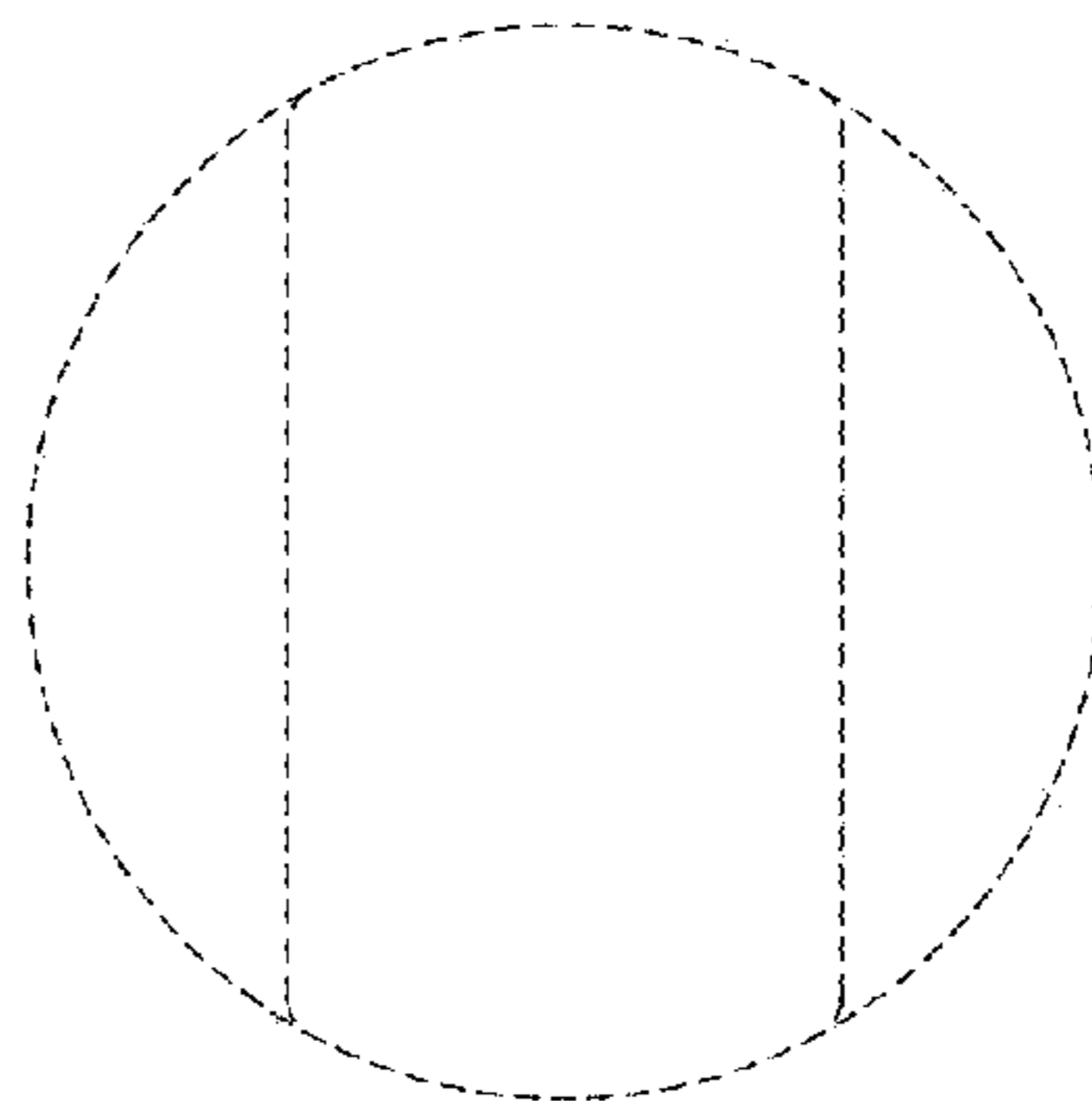

FIG. 5