



US00D761555S

(12) **United States Design Patent**
Philo

(10) **Patent No.:** **US D761,555 S**
(45) **Date of Patent:** **** Jul. 19, 2016**

- (54) **HANDBAG**
- (71) Applicant: **CELINE**, Paris (FR)
- (72) Inventor: **Phoebe Philo**, London (GB)
- (73) Assignee: **Celine**, Paris (FR)
- (**) Term: **14 Years**
- (21) Appl. No.: **29/513,976**
- (22) Filed: **Jan. 7, 2015**

(30) **Foreign Application Priority Data**

Jul. 24, 2014 (EM) 002508796-0001

- (51) **LOC (10) Cl.** **03-01**
- (52) **U.S. Cl.**
USPC **D3/232**
- (58) **Field of Classification Search**
USPC D3/232–238, 240–243, 245–246, 318;
150/100, 103–110, 113–114, 117–119
CPC A45C 3/06; A45C 3/08
See application file for complete search history.

(56) **References Cited**

U.S. PATENT DOCUMENTS

- 3,117,607 A * 1/1964 Siegel A45C 9/00
150/108
- D598,648 S * 8/2009 Stulman D3/232
- D618,909 S * 7/2010 Gaultier D3/243
- D631,656 S * 2/2011 Della Valle D3/243
- D656,313 S * 3/2012 Dumas D3/243

- D684,766 S * 6/2013 Gerbi D3/243
- D698,146 S * 1/2014 Deneve D3/245
- D711,100 S * 8/2014 Dingizian D3/245
- D714,049 S * 9/2014 Wang D3/245
- D745,268 S * 12/2015 Slimane D3/232

* cited by examiner

Primary Examiner — Derrick Holland

Assistant Examiner — Jennifer O King

(74) *Attorney, Agent, or Firm* — Finnegan, Henderson, Farabow, Garrett & Dunner, L.L.P.

(57) **CLAIM**

The ornamented design for a handbag, as shown and described.

DESCRIPTION

FIG. 1 is a front perspective view of a handbag, showing my new design;
 FIG. 2 is a front elevation view thereof;
 FIG. 3 is a rear elevation view thereof;
 FIG. 4 is a right side view thereof;
 FIG. 5 is a left side view thereof;
 FIG. 6 is a top plan view thereof;
 FIG. 7 is a bottom view thereof; and,
 FIG. 8 is a top plan view in an alternate configuration, where the bag is open.

The dash-dash broken lines shown represent unclaimed subject matter and form no part of the claimed design. The dot-dash broken lines shown in the drawings represent an unclaimed boundary between claimed and unclaimed surfaces.

1 Claim, 8 Drawing Sheets

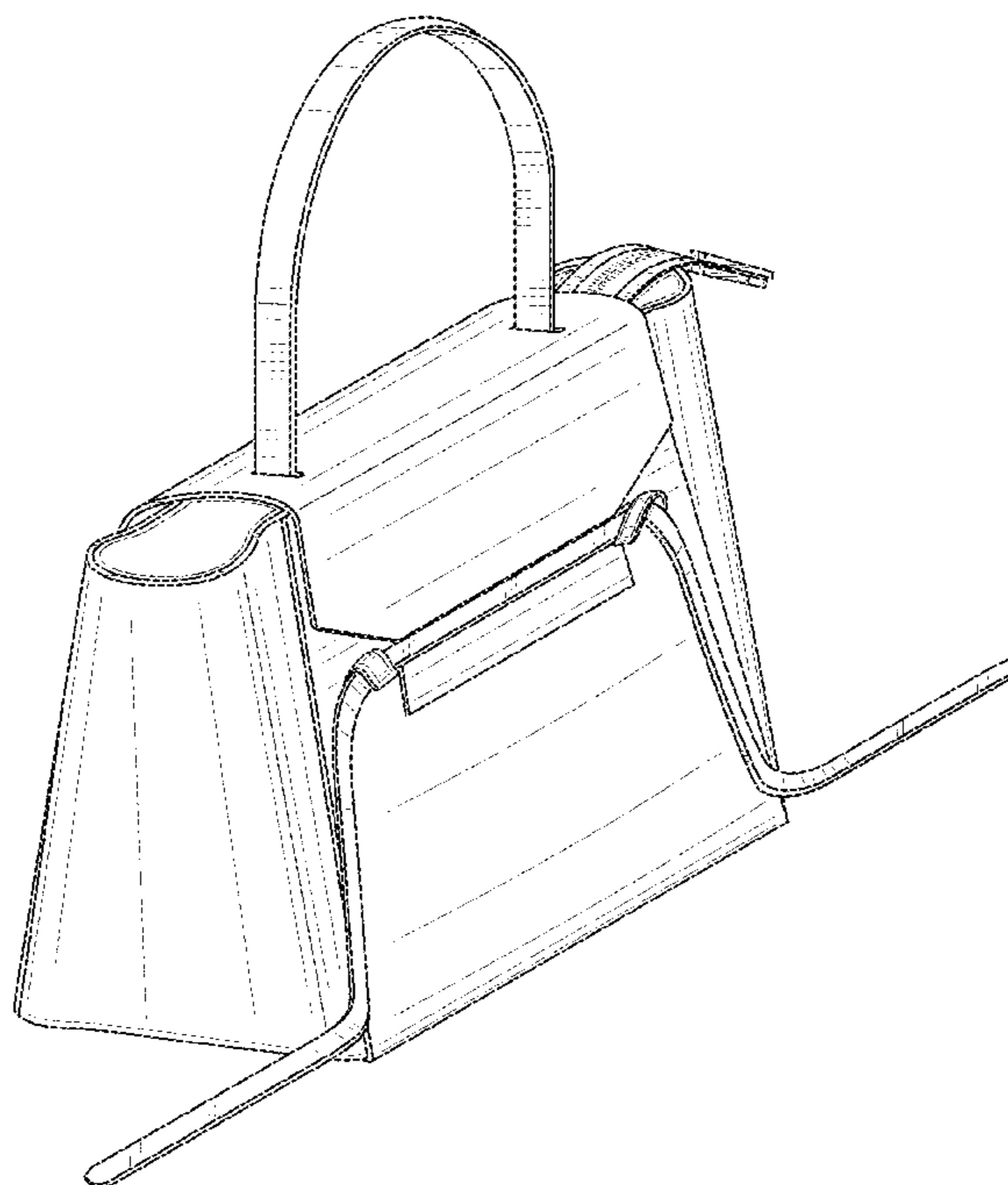

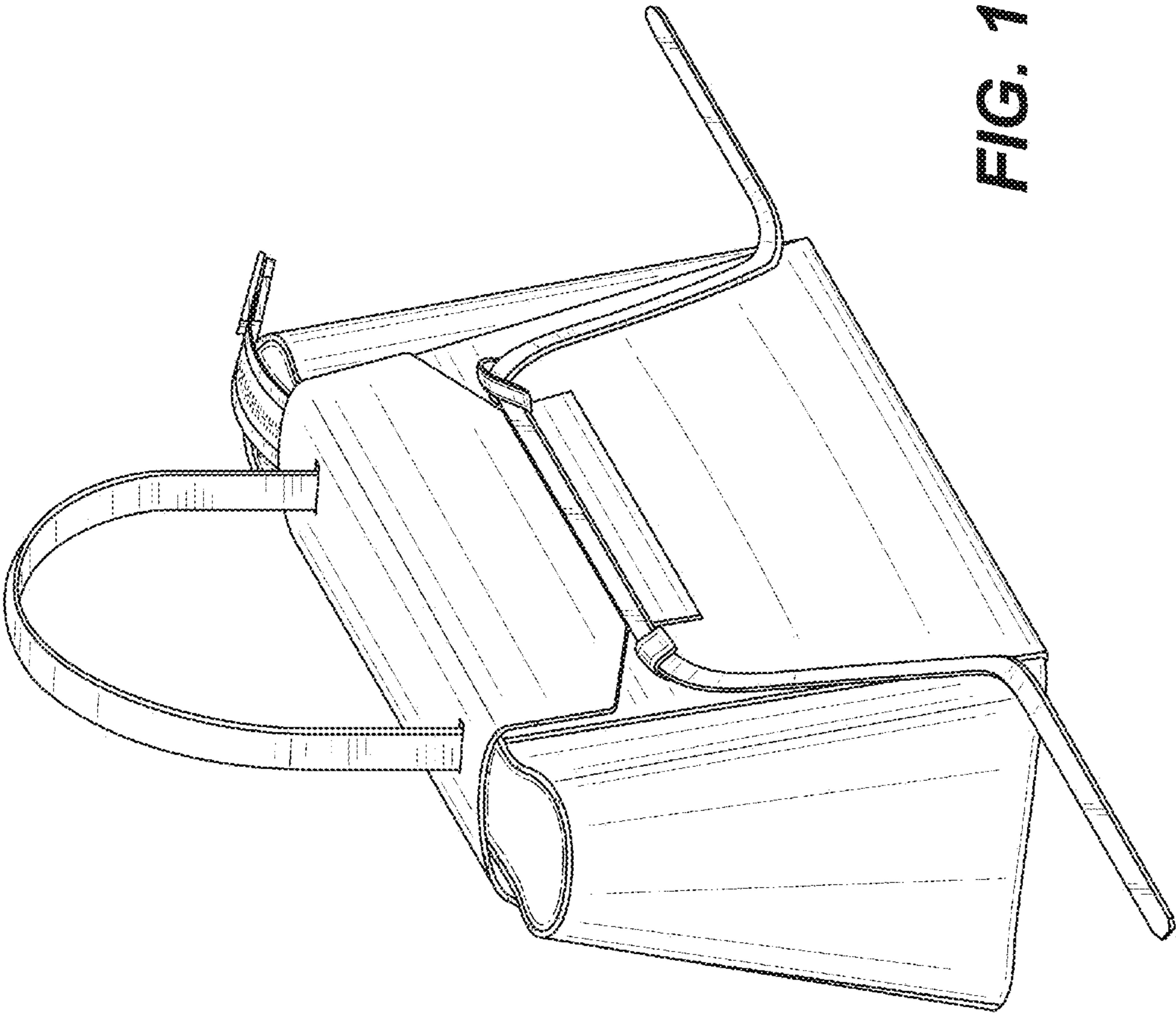

FIG. 1

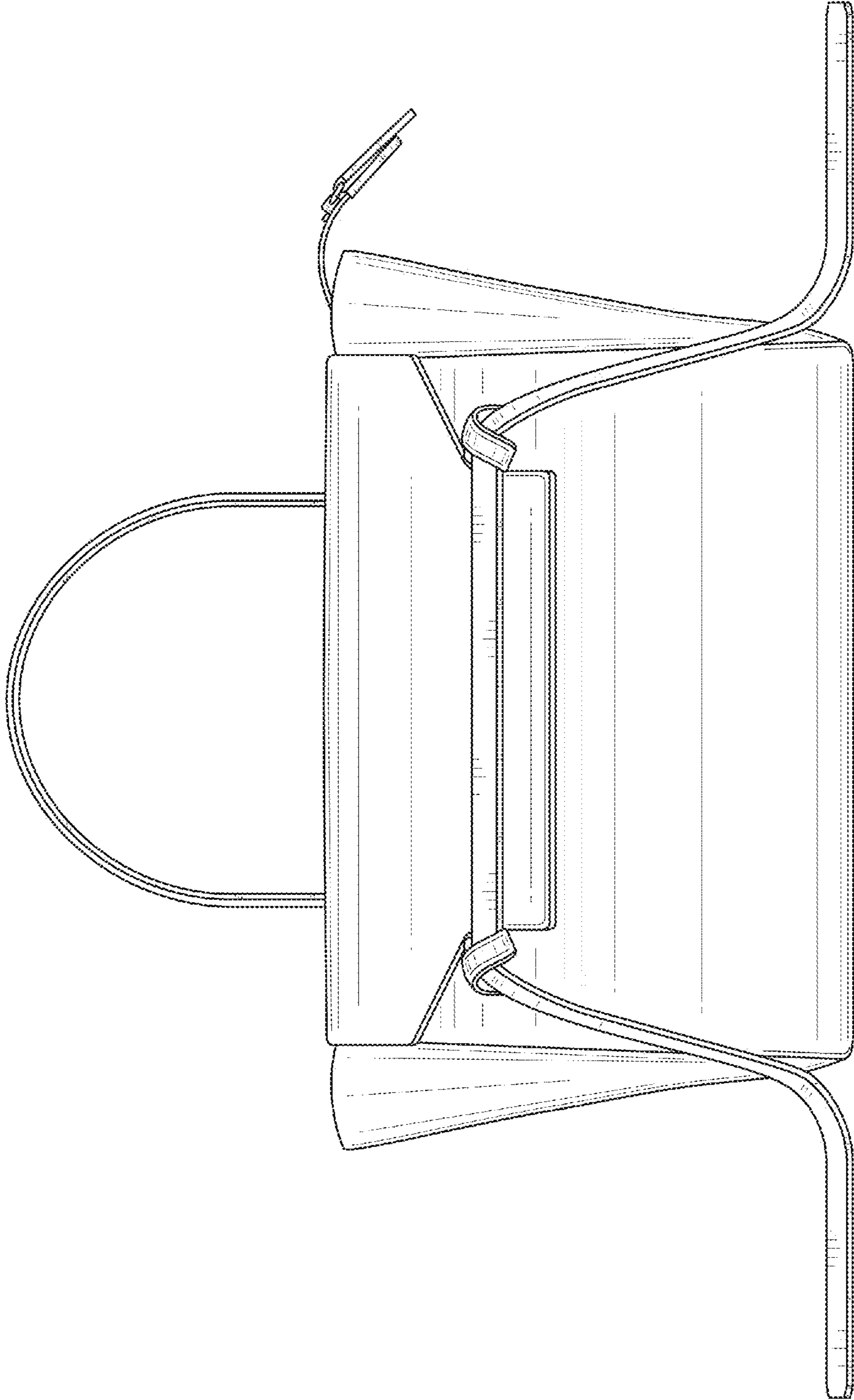

FIG. 2

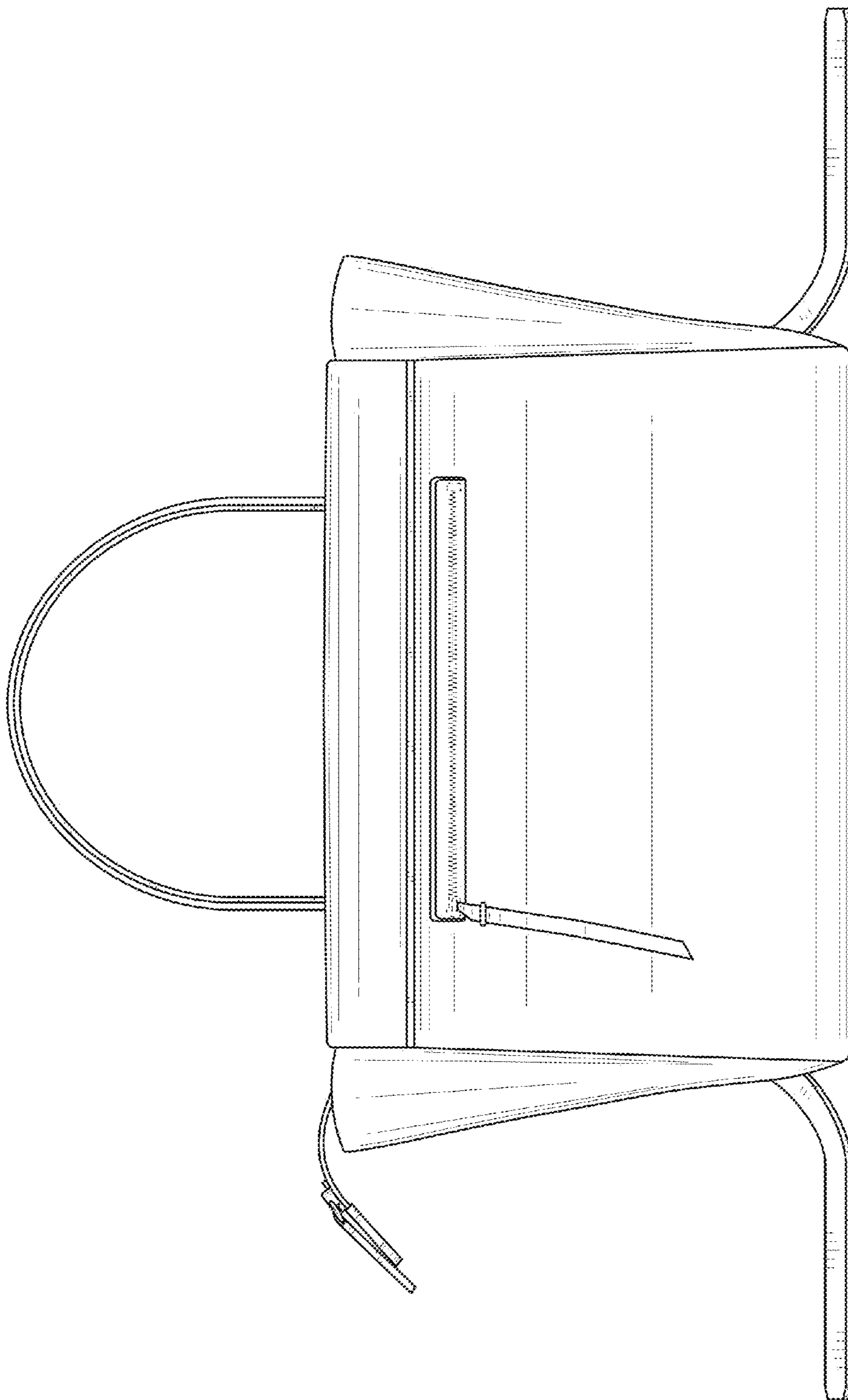

FIG. 3

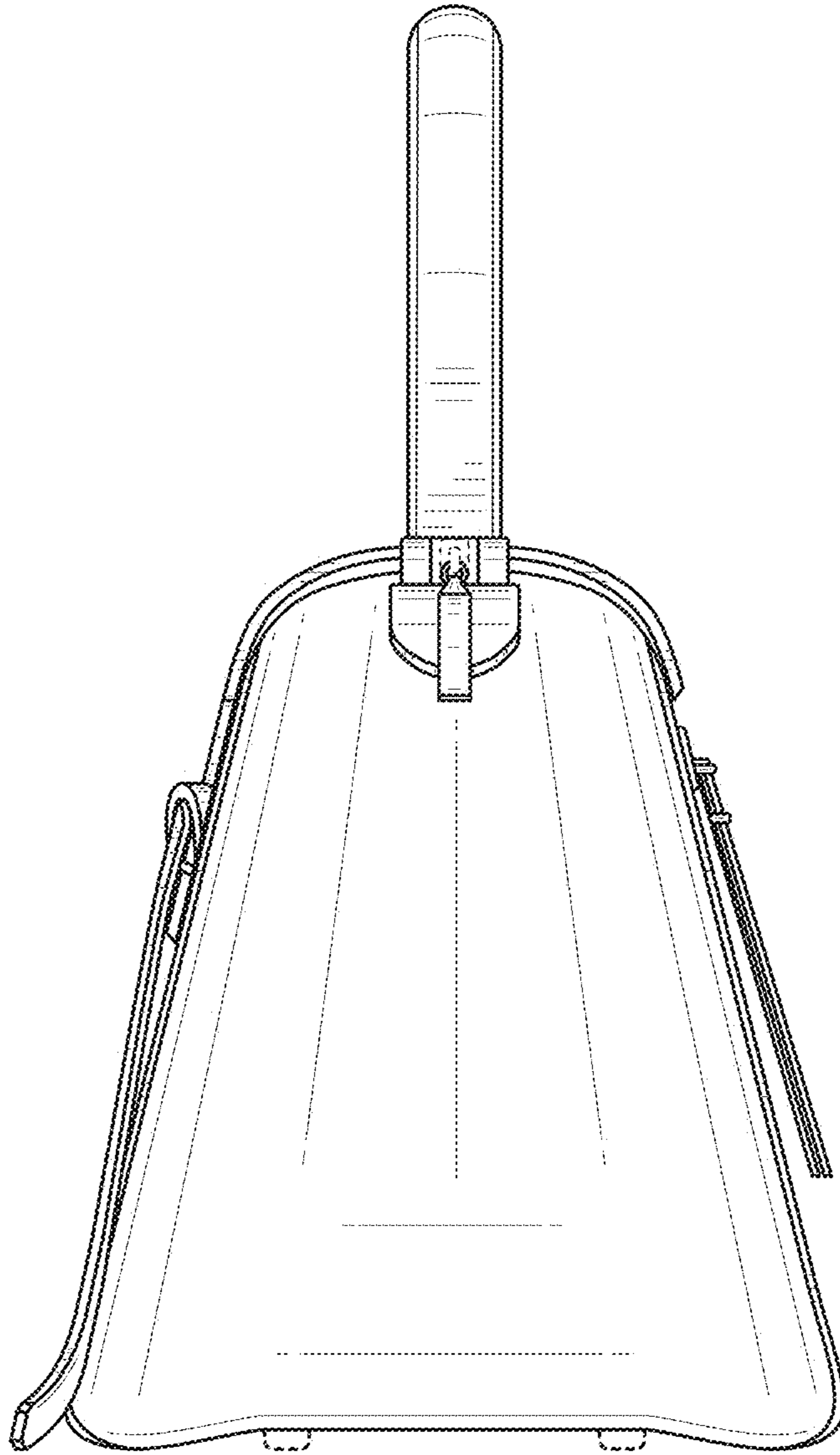

FIG. 4

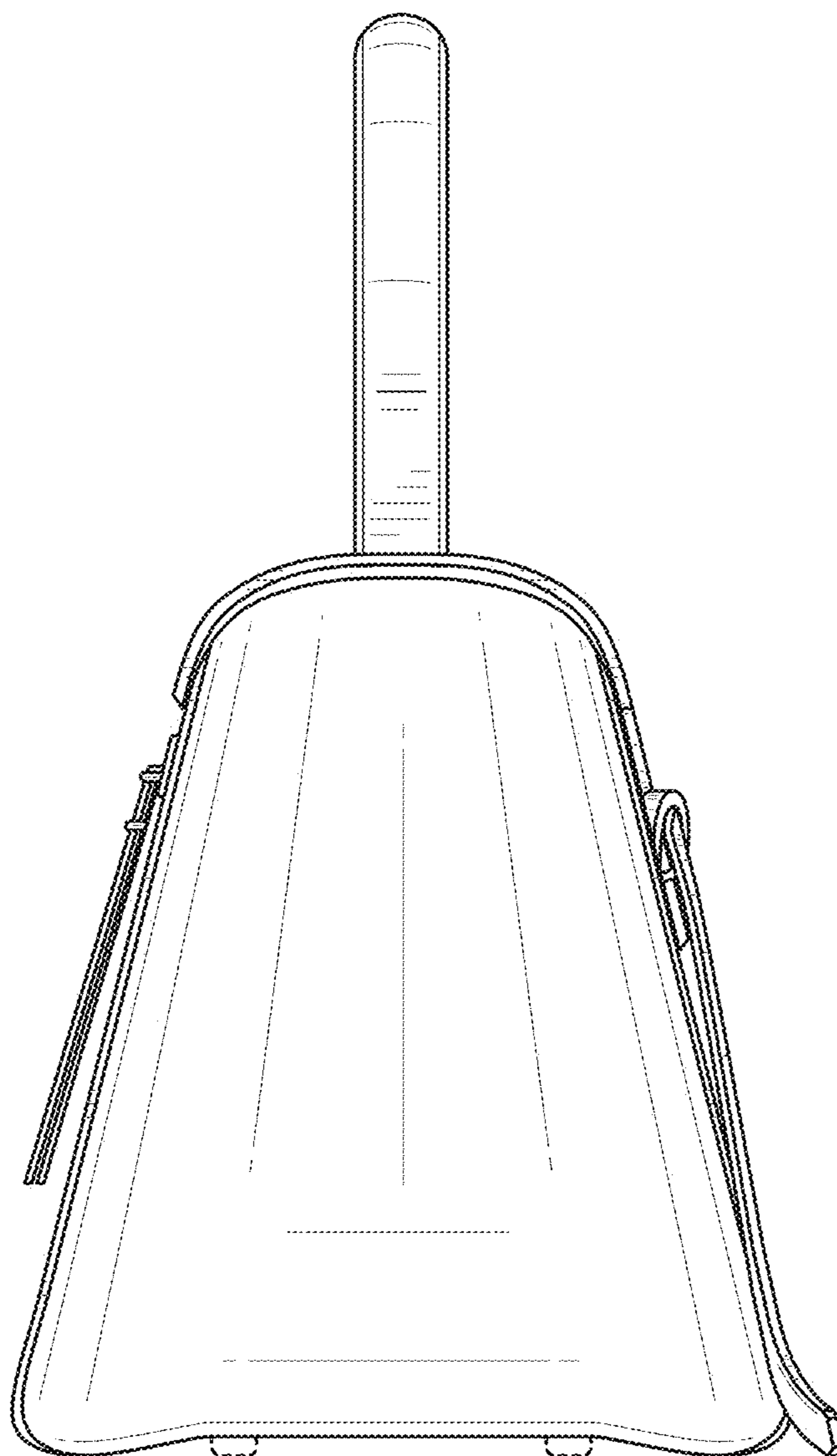

FIG. 5

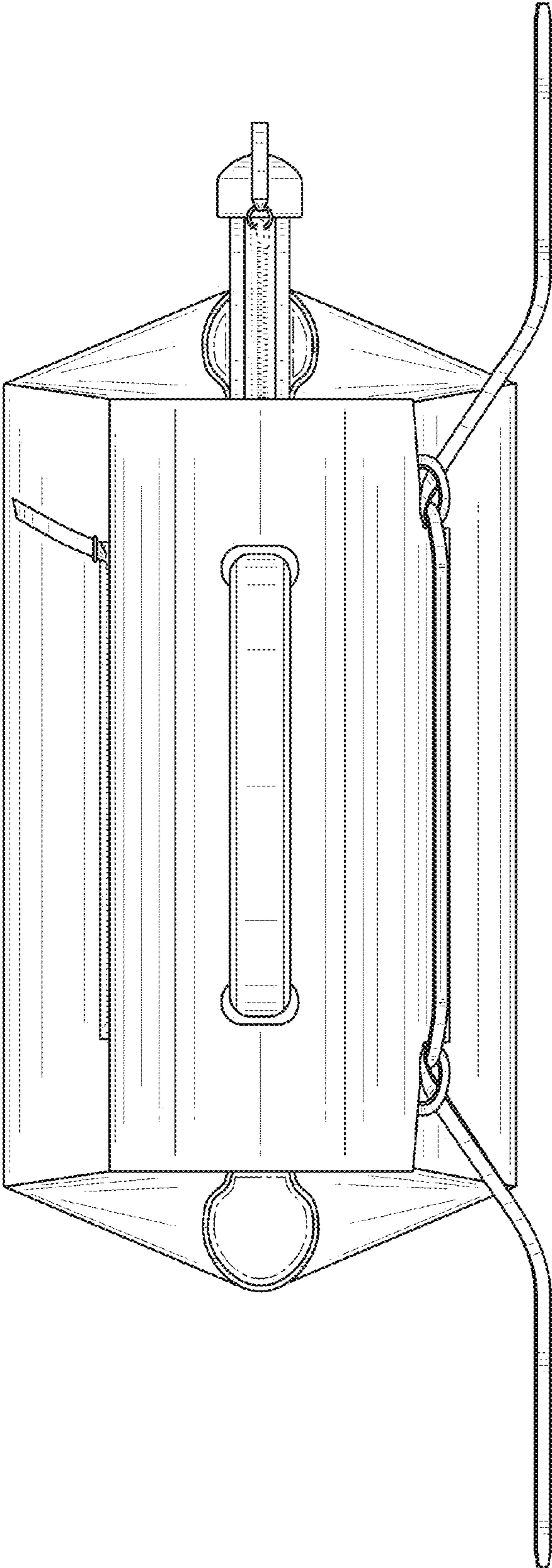

FIG. 6

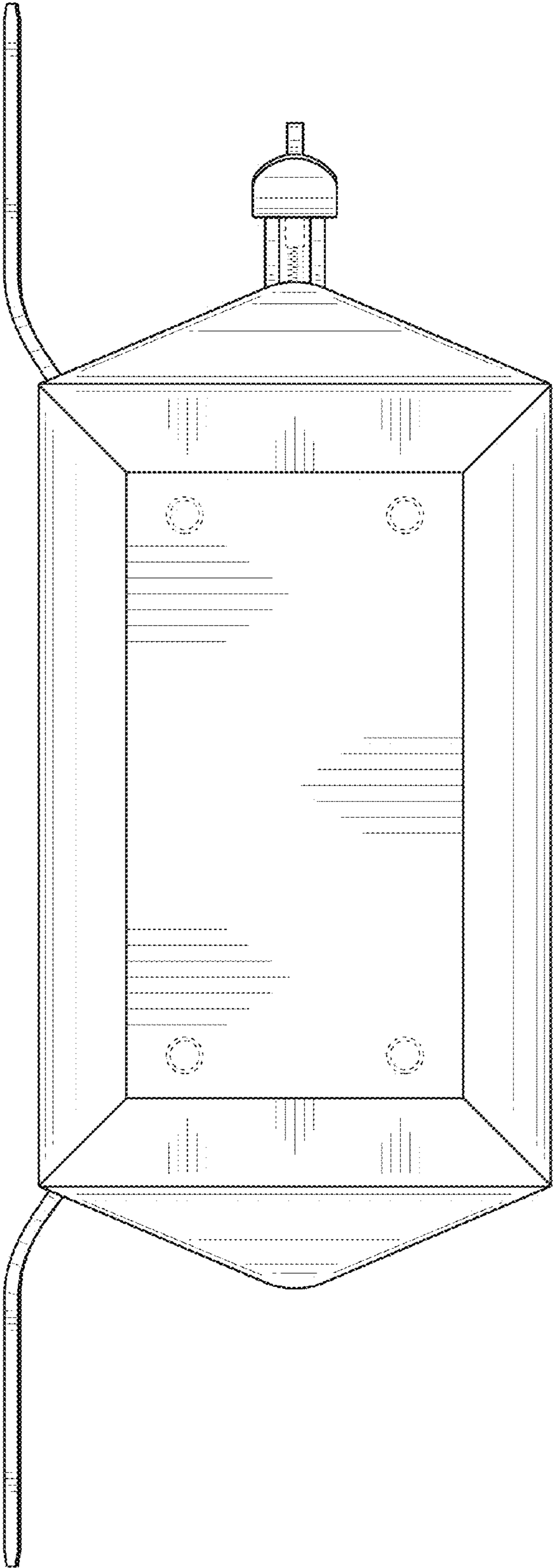

FIG. 7

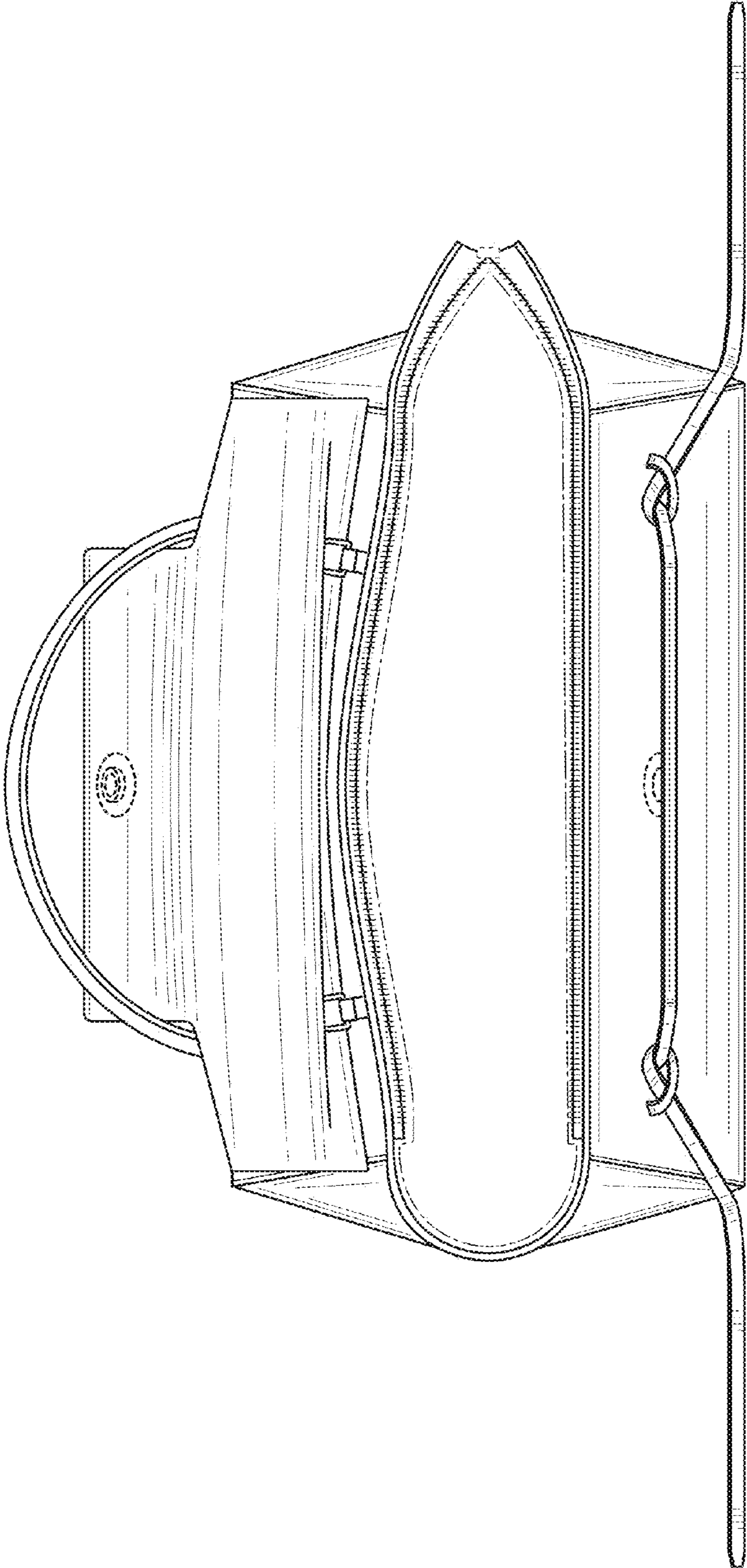

FIG. 8