



US00D761368S

(12) **United States Design Patent**
Holland et al.

(10) **Patent No.:** **US D761,368 S**
(45) **Date of Patent:** **** Jul. 12, 2016**

- (54) **GOLF CLUB GRIP TRAINER**
- (71) Applicant: **Pro Performance Sports, L.L.C.**,
Carlsbad, CA (US)
- (72) Inventors: **Allen Keith Holland**, Carlsbad, CA
(US); **Kash Oris Bell**, Carlsbad, CA
(US)
- (73) Assignee: **PRO PERFORMANCE SPORTS,**
L.L.C., Carlsbad, CA (US)
- (**) Term: **14 Years**
- (21) Appl. No.: **29/521,086**
- (22) Filed: **Mar. 19, 2015**
- (51) **LOC (10) Cl.** **21-02**
- (52) **U.S. Cl.**
USPC **D21/758; D21/791**
- (58) **Field of Classification Search**
USPC **D21/756-758, 791**
CPC **A63B 53/14; A63B 69/3632; A63B 60/46**
See application file for complete search history.

- 5,984,795 A * 11/1999 Stafford A63B 53/14
473/206
- D449,360 S * 10/2001 Kallassy D21/758
- 6,540,621 B1 * 4/2003 Robinson A63B 69/3632
473/201
- D520,091 S * 5/2006 Leadbetter D21/758
- 7,537,525 B2 * 5/2009 Wang A63B 69/3632
473/206
- D598,513 S * 8/2009 Bleecker D21/758
- D629,858 S * 12/2010 Wilson D21/758
- D643,898 S * 8/2011 Astrella D21/758
- D682,967 S * 5/2013 Shealy D21/791
- D736,332 S * 8/2015 Daniel D21/756
- 2002/0151373 A1 * 10/2002 Beauregard A63B 69/3632
473/206
- 2004/0242341 A1 * 12/2004 McDonald A63B 53/14
473/303

* cited by examiner

Primary Examiner — Mitchell Siegel

(74) *Attorney, Agent, or Firm* — Kevin Buckley

(57) **CLAIM**

The ornamental design for a golf club grip trainer, as shown and described.

DESCRIPTION

FIG. 1 is a top, front and left side perspective view showing our new design.

FIG. 2 is a left side view.

FIG. 3 is a bottom view.

FIG. 4 is a top view.

FIG. 5 is a right side view.

FIG. 6 is a front end view; and,

FIG. 7 is a back end view.

1 Claim, 3 Drawing Sheets

(56) **References Cited**
U.S. PATENT DOCUMENTS

- D125,602 S * 3/1941 Wheeler et al. 473/203
- 2,628,100 A * 2/1953 Beebe A63B 60/22
473/203
- D341,178 S * 11/1993 Rice D21/756
- 5,299,802 A * 4/1994 Bouchet-Lassale ... A63B 49/08
273/DIG. 30
- 5,398,930 A * 3/1995 Gibson A63B 53/14
473/201

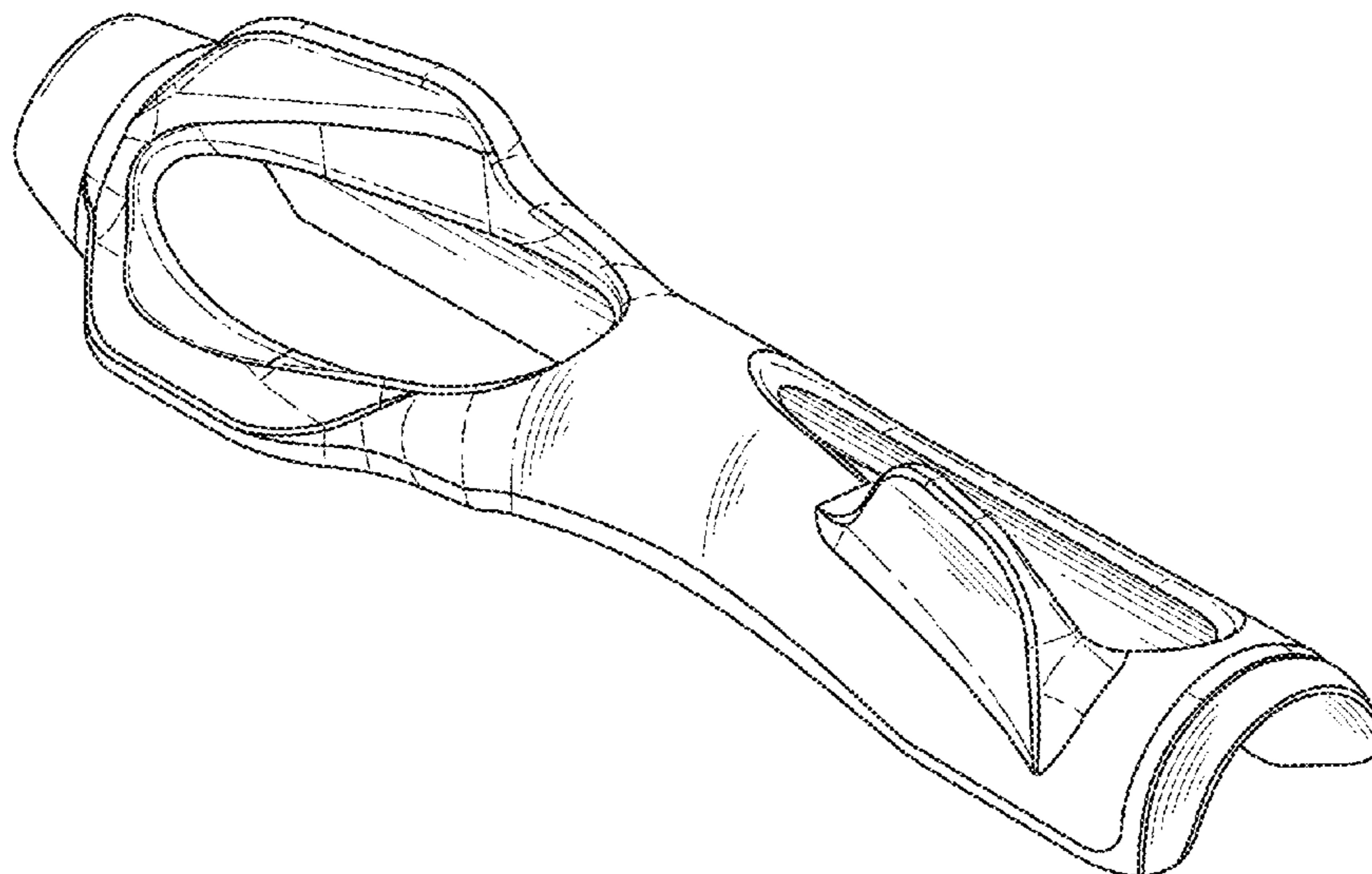

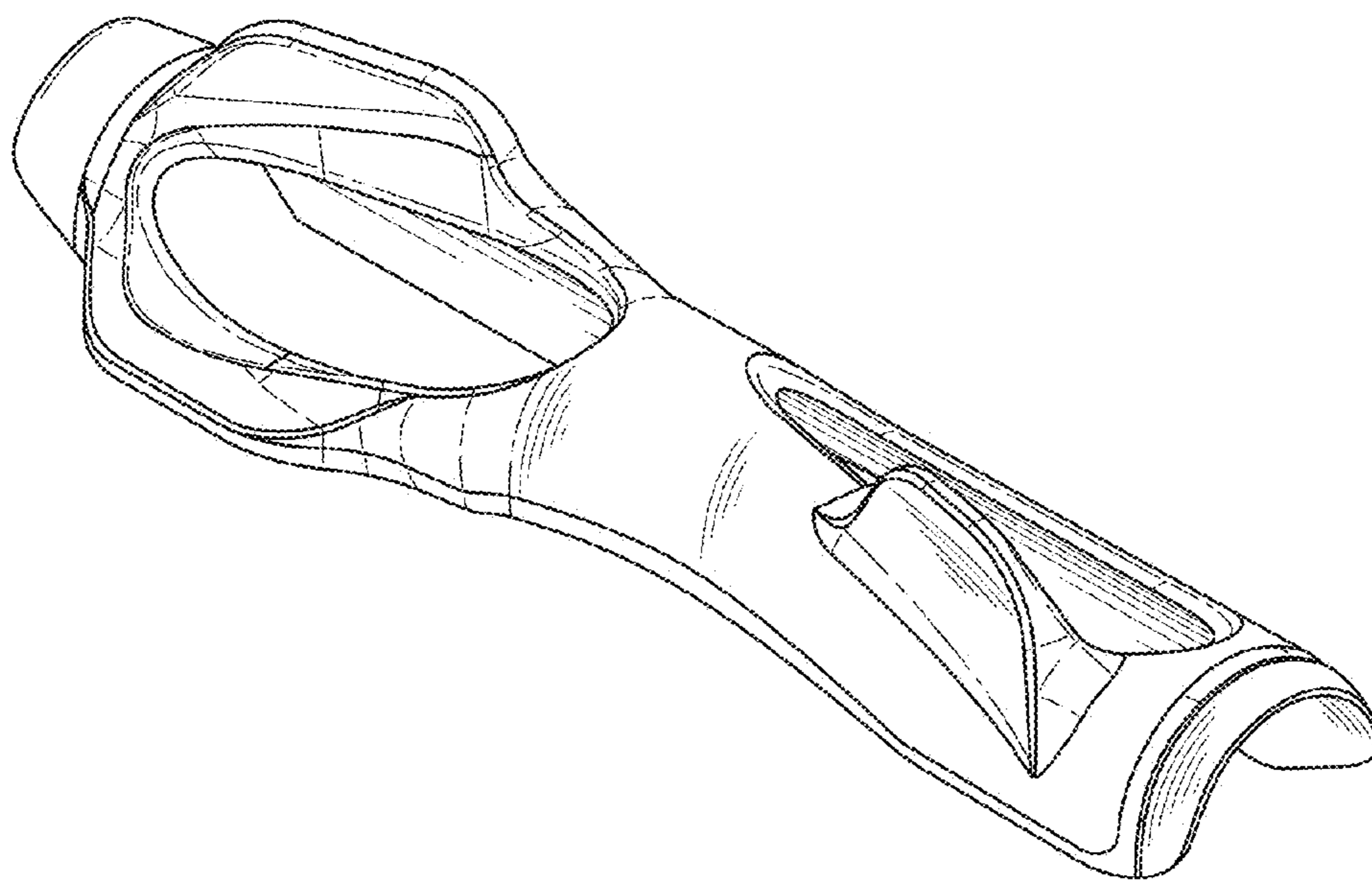

FIG. 1

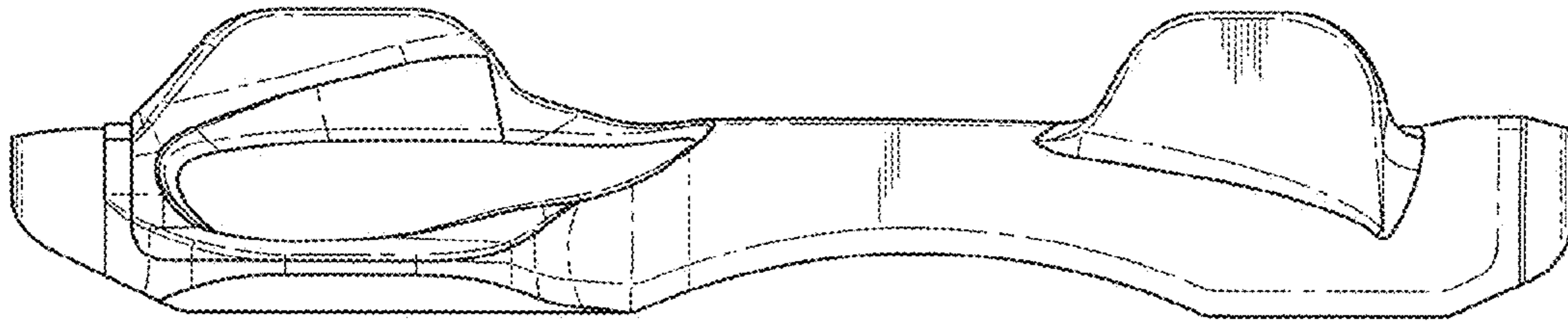

FIG. 2

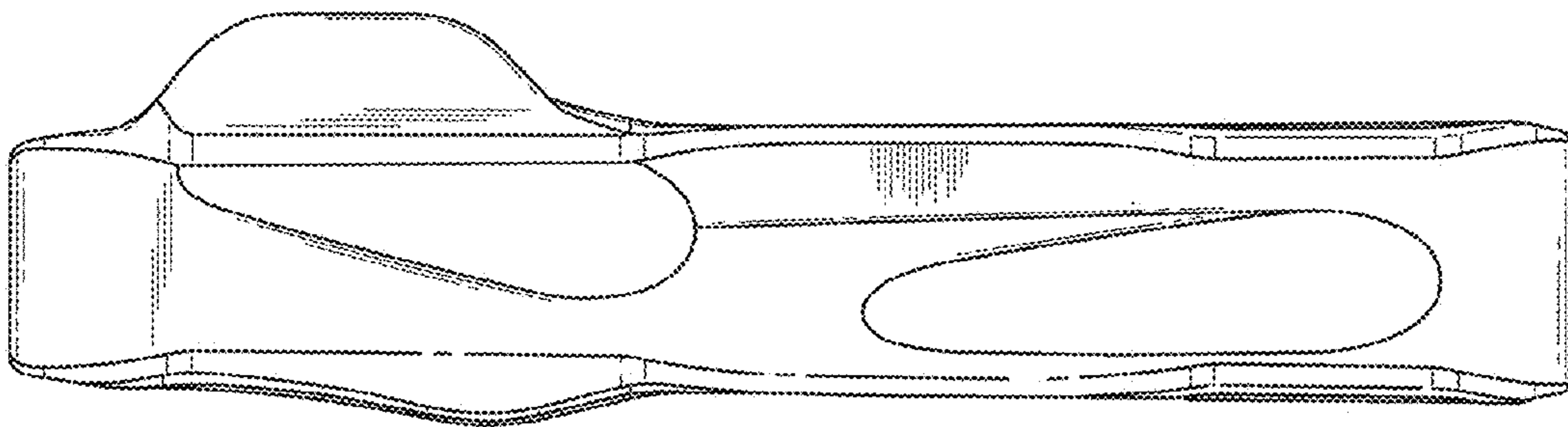

FIG. 3

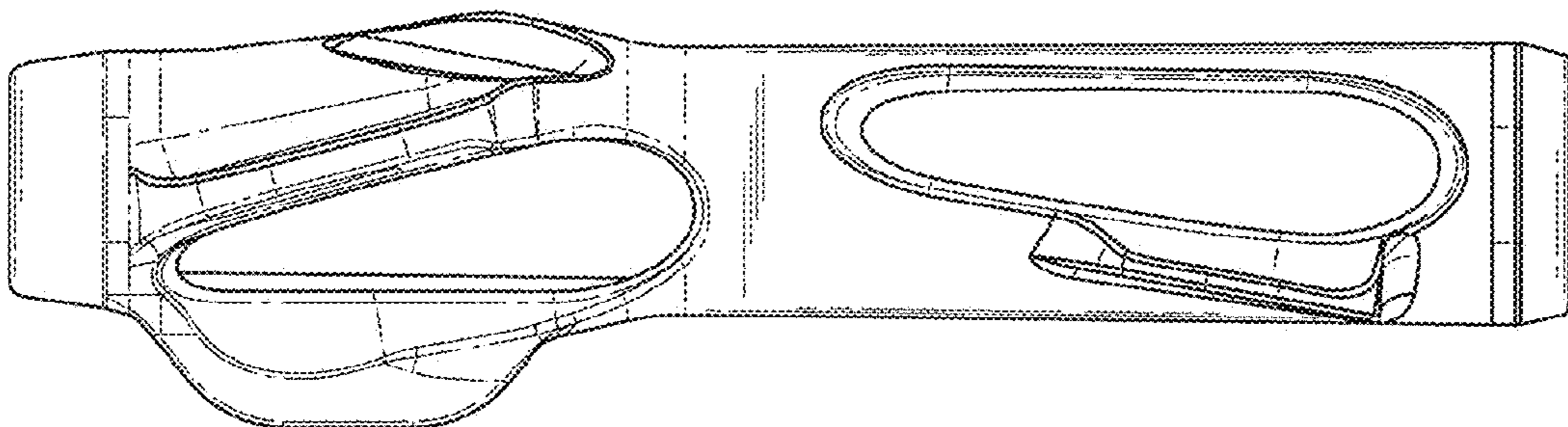

FIG. 4

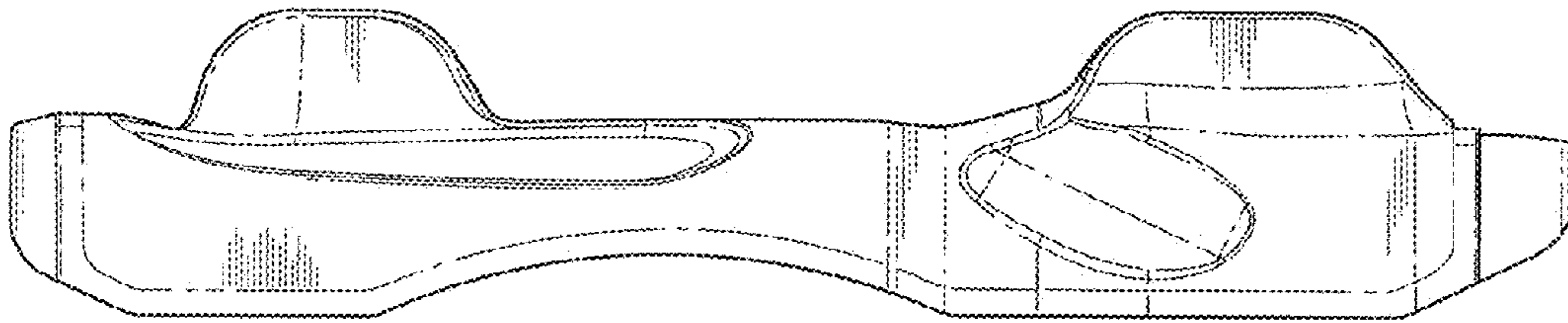

FIG. 5

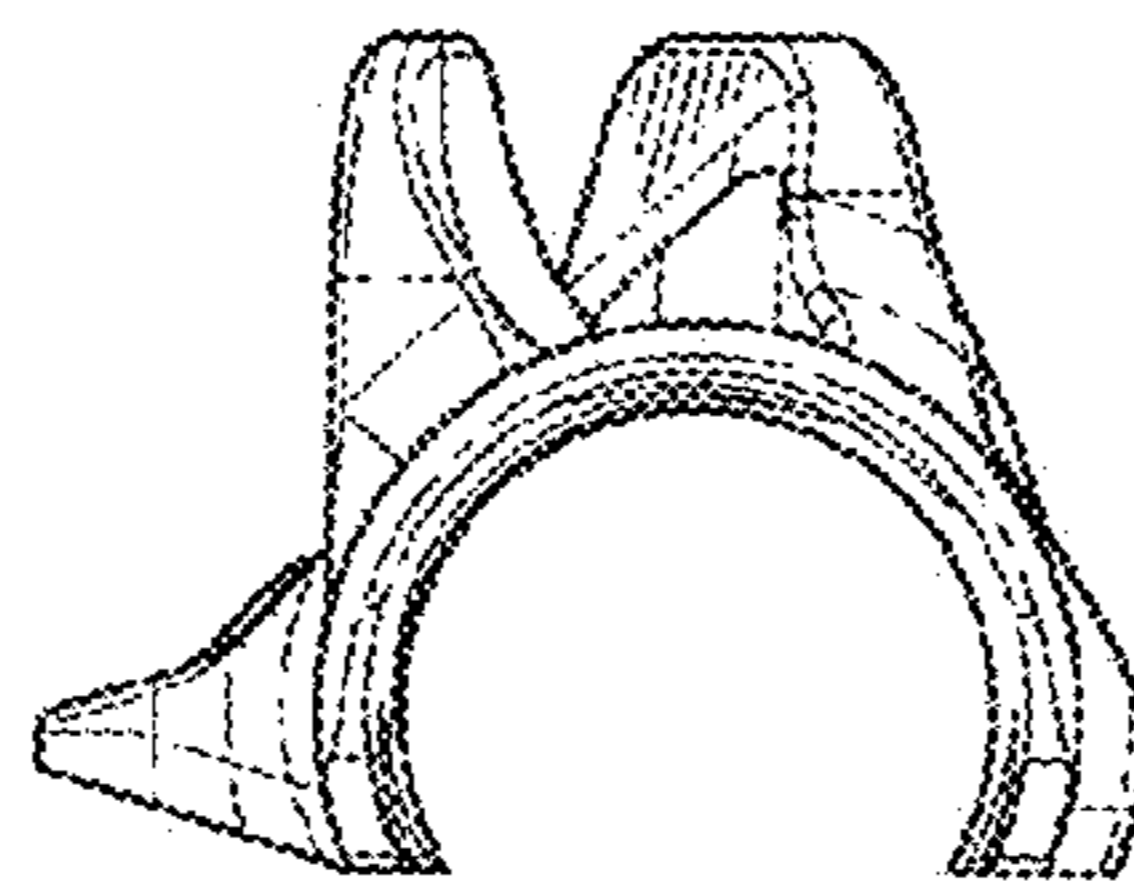

FIG. 6

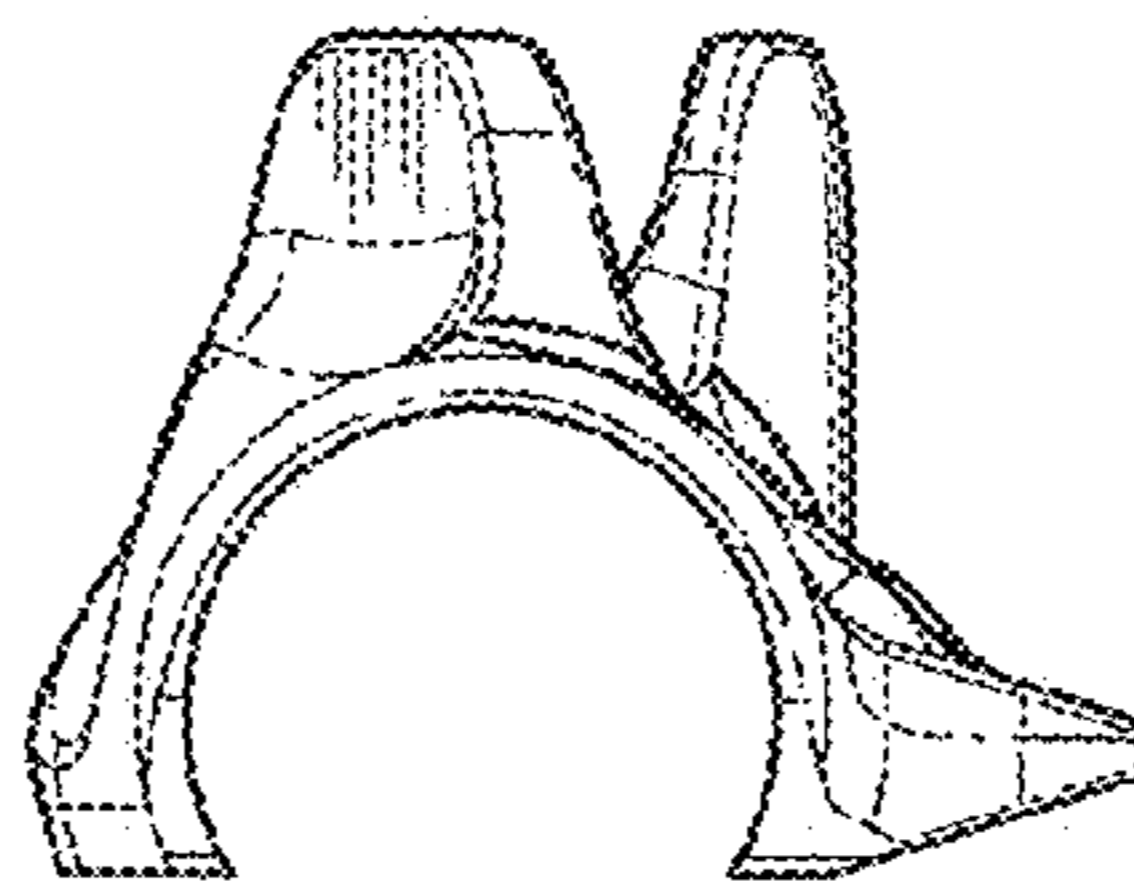

FIG. 7