

US00D761242S

(12) **United States Design Patent**
Voron et al.

(10) **Patent No.:** **US D761,242 S**
(45) **Date of Patent:** **** Jul. 12, 2016**

- (54) **DISPLAY**
- (71) Applicant: **Dolby Laboratories Licensing Corporation**, San Francisco, CA (US)
- (72) Inventors: **Vincent Voron**, Menlo Park, CA (US); **Peter Michaelian**, Tappan, NY (US); **Lucas E. Saule**, San Francisco, CA (US); **Donald Burlock**, San Bruno, CA (US)
- (73) Assignee: **Dolby Laboratories Licensing Corporation**, San Francisco, CA (US)
- (**) Term: **14 Years**
- (21) Appl. No.: **29/517,146**
- (22) Filed: **Feb. 10, 2015**
- (51) **LOC (10) Cl.** **14-02**
- (52) **U.S. Cl.**
USPC **D14/302**
- (58) **Field of Classification Search**
USPC D14/300, 304-308, 126, 496; D13/163; D12/319; D6/641, 642, 664
CPC A47B 21/00; A47B 21/06; A47B 13/08; A47B 35/00; A47B 21/0314; A47B 17/003; A47B 83/001; G06Q 20/10; G06Q 20/18; G06Q 20/20; G06Q 20/123; A47F 9/047; A47G 5/00; E04B 2/7433; E04H 3/24
See application file for complete search history.

- D566,703 S * 4/2008 Malone D14/307
- D651,784 S * 1/2012 Rohan D14/307
- D681,612 S * 5/2013 Palacios D14/172
- D707,674 S * 6/2014 Daniel D14/307
- 8,783,328 B2 7/2014 Melhart
- 2014/0126753 A1 5/2014 Takumai et al.

FOREIGN PATENT DOCUMENTS

- JP 60259086 A 12/1985
- JP 6078392 A 3/1994

OTHER PUBLICATIONS

Video Stands and Workstations, Goodfrey Group at <<http://www.goodfreygroup.com/products/pedestals-kiosks-workstations/video-stands-workstations-pedestals.html>>, available at least as early as Sep. 8, 2014.
The Exhibition—Inspiration, Evolution of Listening at <<http://kayontheradio.wordpress.com/209/05/05/the-exhibition-inspiration/>>, available at least as early as May 5, 2013.

(Continued)

Primary Examiner — Freda S Nunn

(57) **CLAIM**
The ornamental design for a display, as shown and described.

DESCRIPTION

FIG. 1 is a front perspective view of a display showing our new design;
FIG. 2 is a front view thereof;
FIG. 3 is a right side view thereof, the left side being a mirror image thereof;
FIG. 4 is a rear view thereof;
FIG. 5 is a top view thereof; and,
FIG. 6 is a bottom view thereof.
The dotted broken lines illustrate structure or features that form no part of the claimed design.
The dot-dash broken lines illustrate boundaries of the claimed design; the boundaries themselves form no part of the claimed design.
The drawings include surface shading which represents contour, not surface ornamentation.

1 Claim, 4 Drawing Sheets

(56) **References Cited**

U.S. PATENT DOCUMENTS

- 4,241,777 A * 12/1980 Wenger A47G 5/00 160/135
- 5,646,378 A * 7/1997 Van Haaff H04R 5/02 181/144
- 5,651,405 A * 7/1997 Boeddeker E04H 3/24 160/135
- D519,115 S * 4/2006 Lee D14/307

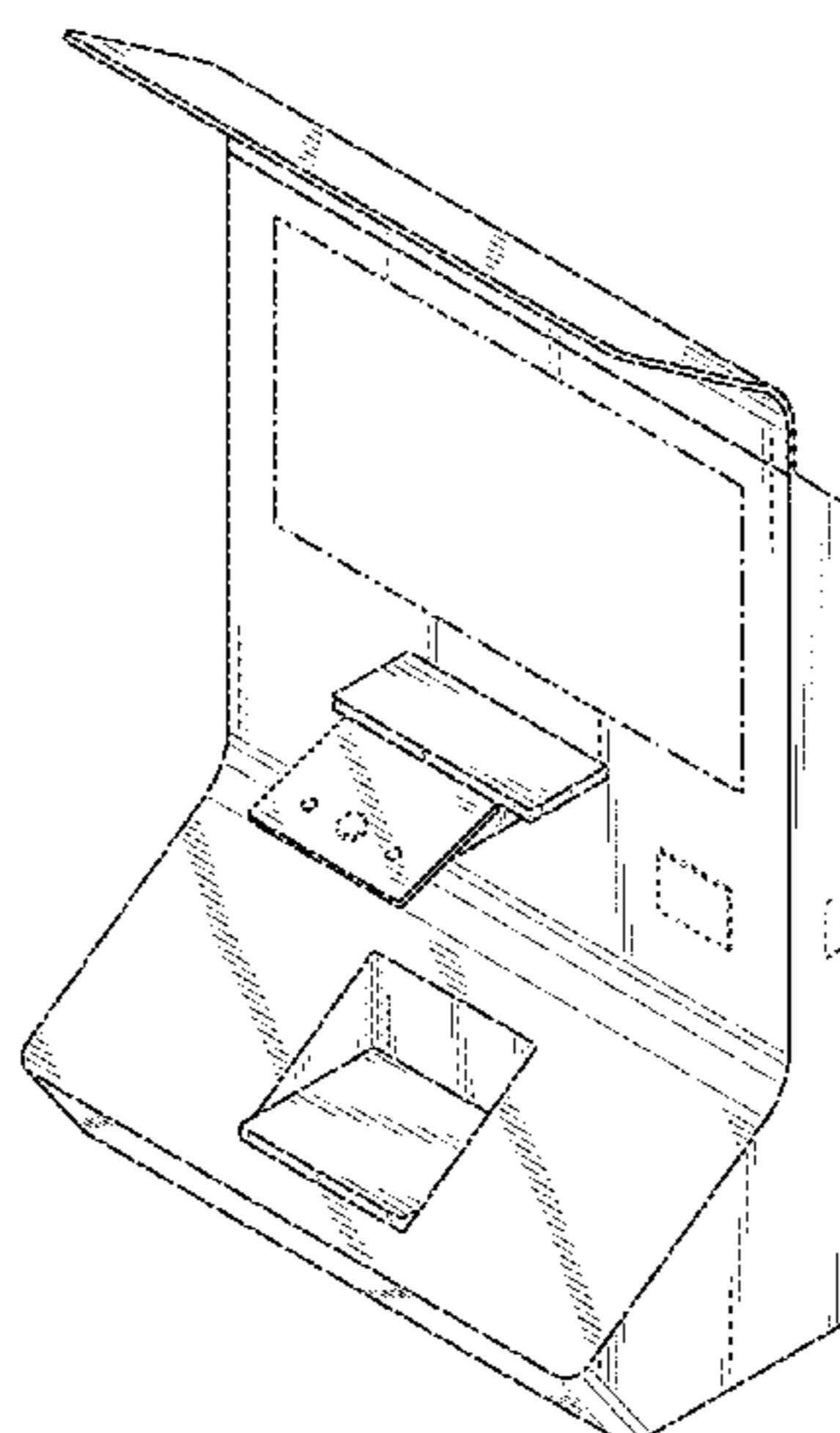

(56)

References Cited

OTHER PUBLICATIONS

Elipson revives a classic design to celebrate its 60th anniversary, What Hi Fi at <<http://www.whathifi.com/news/elipson-revives-classic-de->

sign-to-celebrate-its-60th-anniversary>, available at least as early as Jan. 19, 2012.

U.S. Appl. No. 29/517,152 of Alan J. Seefeldt et al. titled "Display" filed Feb. 10, 2015. (Unpublished).

* cited by examiner

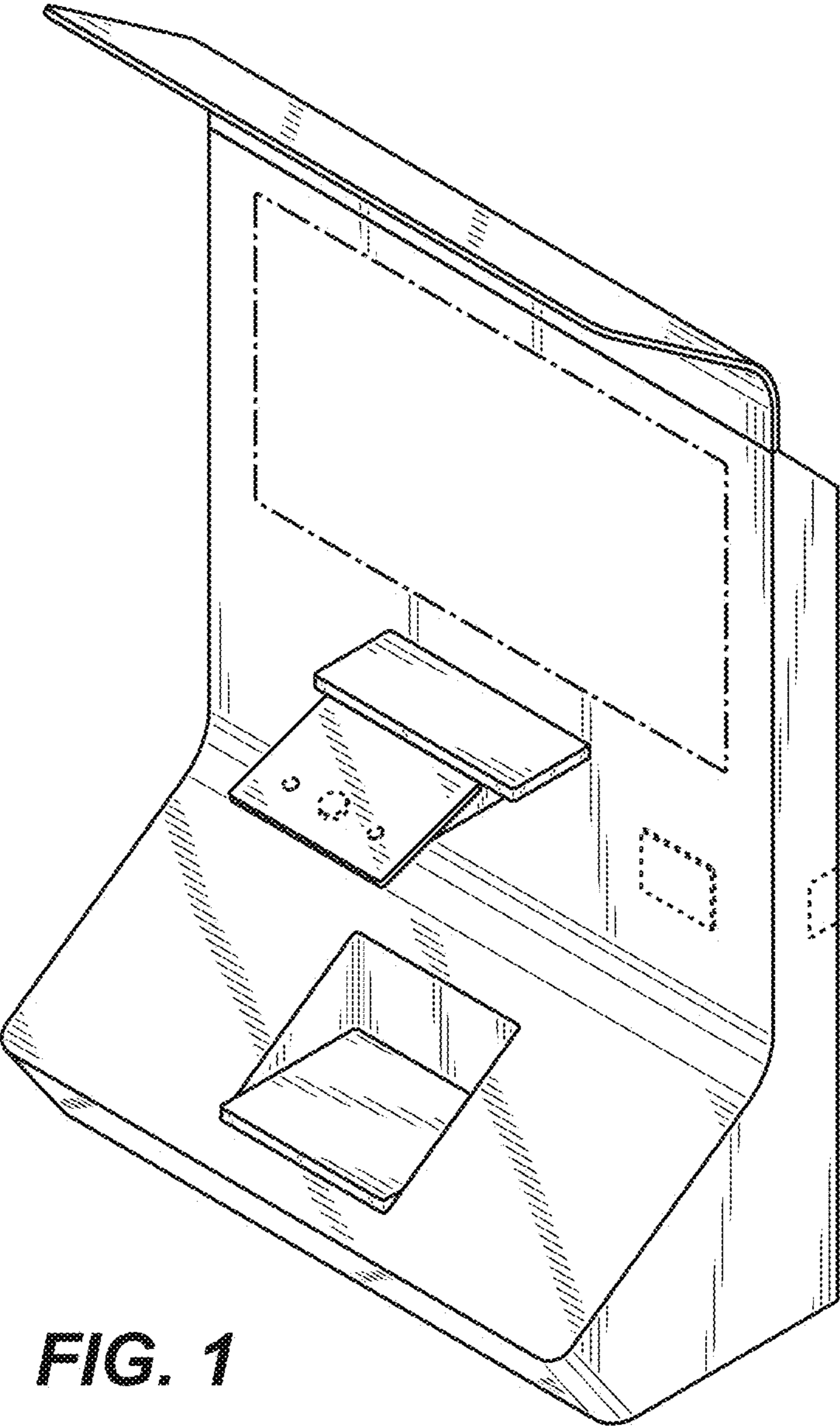

FIG. 1

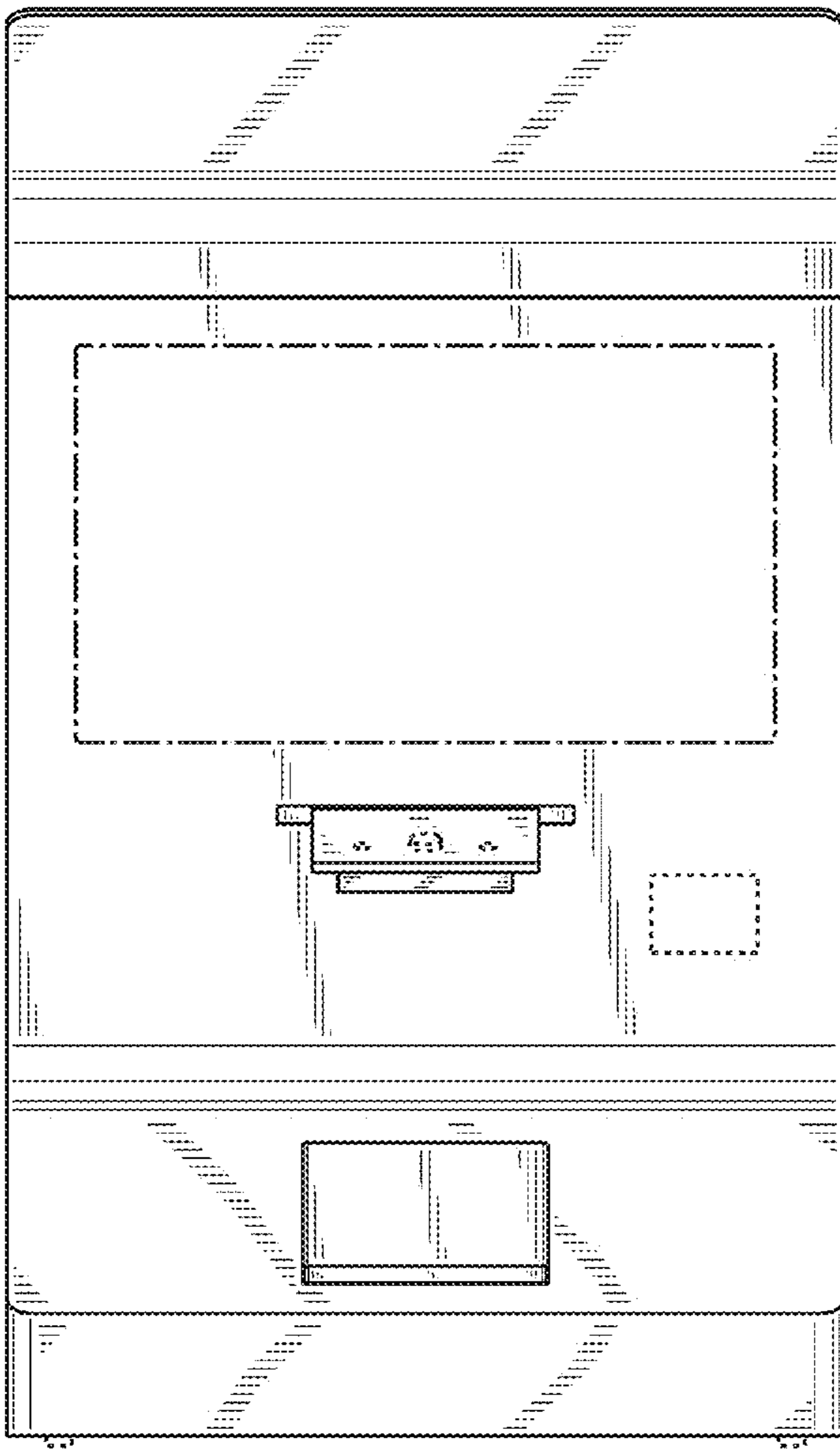

FIG. 2

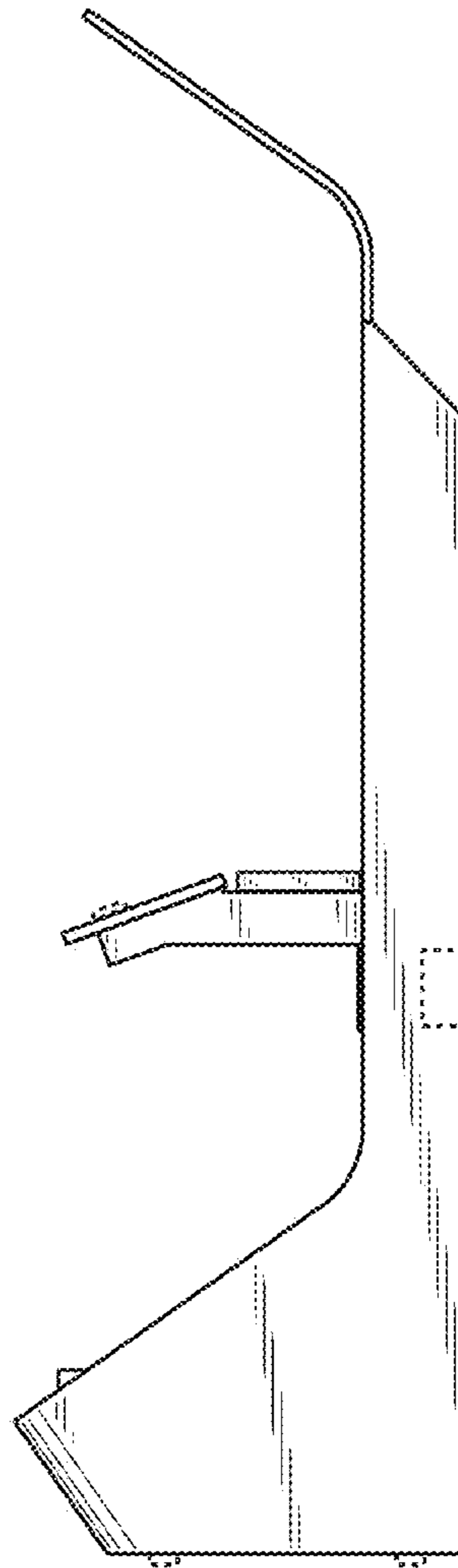

FIG. 3

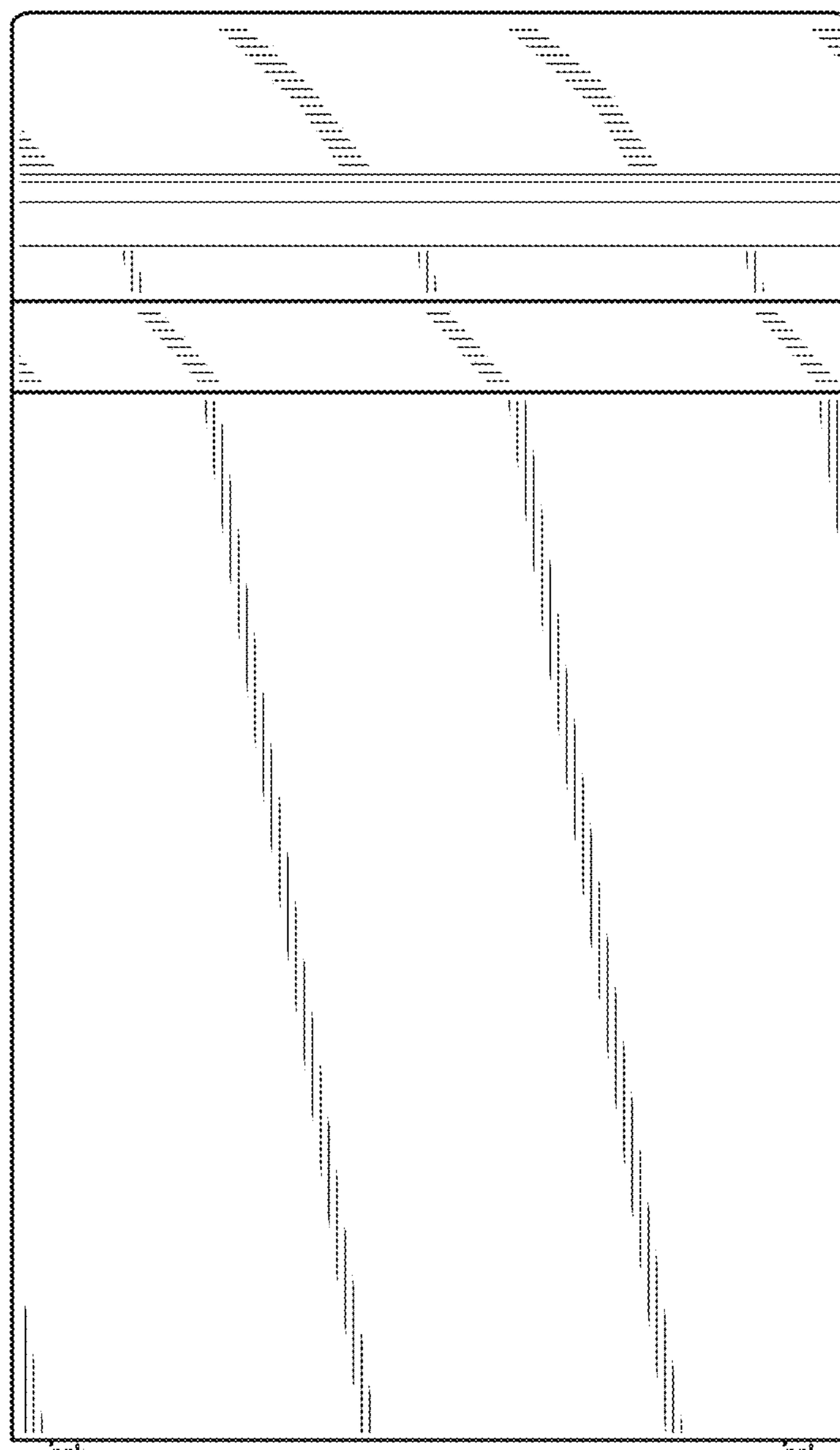

FIG. 4

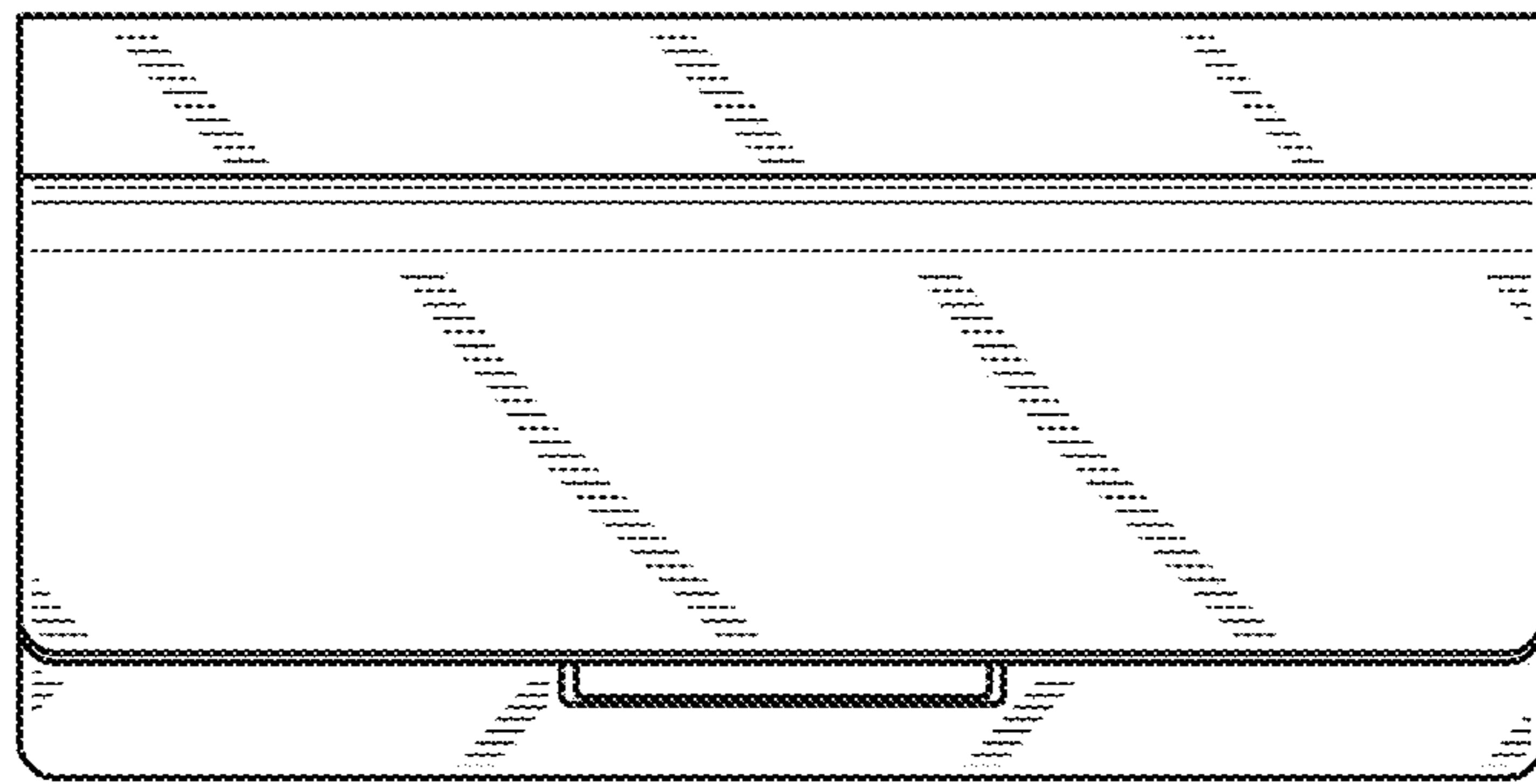

FIG. 5

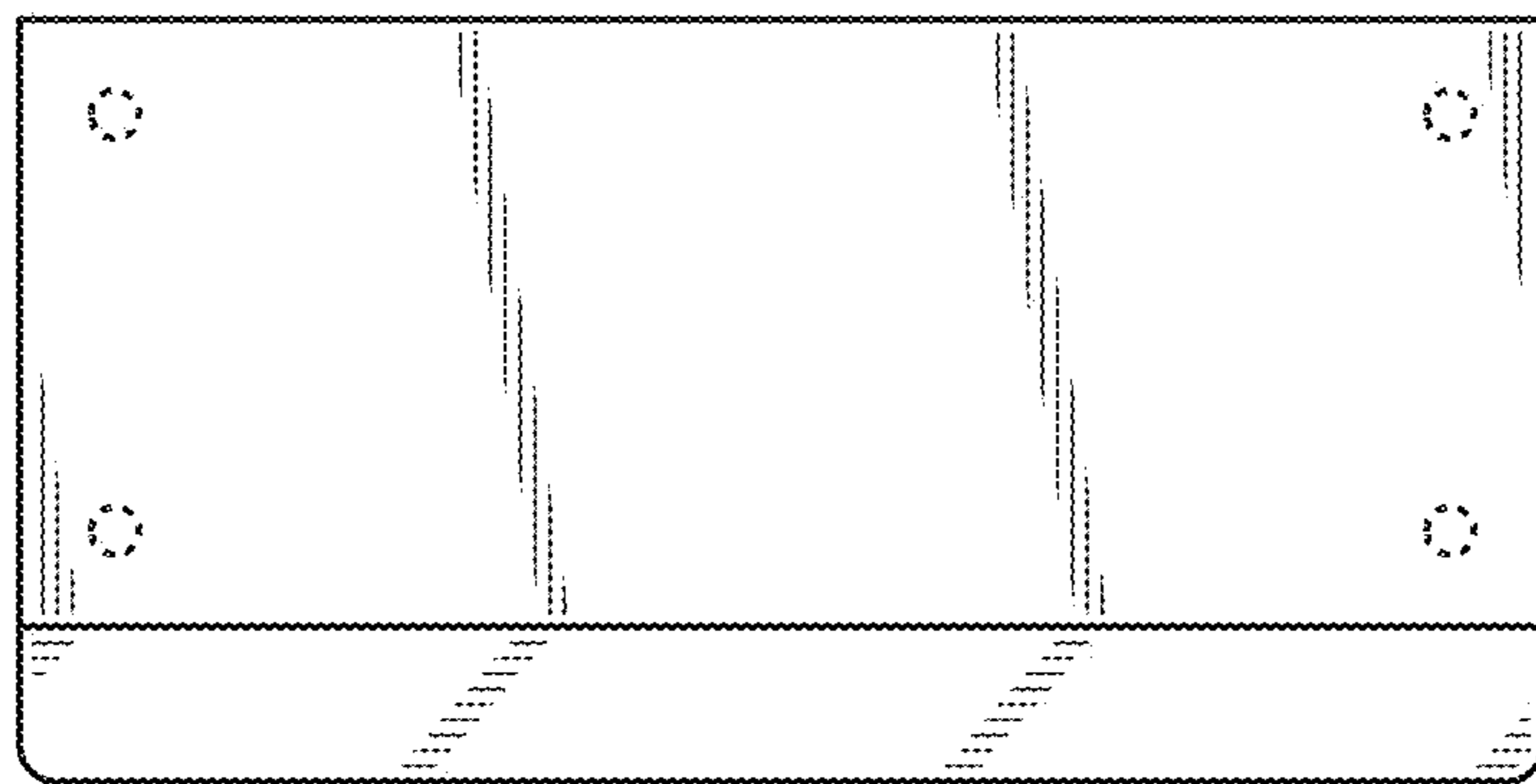

FIG. 6