



US00D761160S

(12) **United States Design Patent**
Gilles Duros et al.

(10) **Patent No.:** **US D761,160 S**
(45) **Date of Patent:** **** Jul. 12, 2016**

- (54) **MODULAR UTILITY TRAILER**
- (71) Applicants: **Jacqueline M. Gilles Duros**, Lake Geneva, WI (US); **Jeffrey C. Duros**, Lake Geneva, WI (US)
- (72) Inventors: **Jacqueline M. Gilles Duros**, Lake Geneva, WI (US); **Jeffrey C. Duros**, Lake Geneva, WI (US)
- (**) Term: **14 Years**
- (21) Appl. No.: **29/518,698**
- (22) Filed: **Feb. 26, 2015**
- (51) **LOC (10) Cl.** **12-10**
- (52) **U.S. Cl.**
USPC **D12/101**
- (58) **Field of Classification Search**
USPC D12/100–106, 19, 129, 111–112;
D21/425, 435; D34/21–26, 12, 16–19
CPC B62D 35/02; B62D 35/00; A62D 35/005;
B60P 3/10; B60P 3/1033; E01F 15/14
See application file for complete search history.

(56) **References Cited**

U.S. PATENT DOCUMENTS

2,879,072	A	3/1959	Rear et al.	
3,403,924	A	10/1968	Oliveira	
D219,860	S *	2/1971	Jones et al.	D12/101
3,798,814	A *	3/1974	Harmon	B60R 13/00 116/63 P
4,511,181	A	4/1985	Schantz	
4,813,841	A	3/1989	Eischen	
5,544,944	A	8/1996	Keech	
5,647,489	A	7/1997	Bellis, Jr.	
5,964,358	A	10/1999	Hafendorfer et al.	
6,409,029	B1	6/2002	Bermes	
6,619,485	B1	9/2003	Jenkins	
6,733,219	B1	5/2004	Floe	
6,846,003	B2	1/2005	Thompson	
7,229,090	B2	6/2007	Cumbie	
7,390,065	B2	6/2008	Pieschel et al.	
7,617,626	B2 *	11/2009	Balscheit	G09F 21/04 40/590
7,644,846	B2	1/2010	Hafendorfer et al.	

- D616,030 S * 5/2010 Mallard D12/101
- 7,891,697 B1 2/2011 Fahrback
- D648,656 S * 11/2011 Crane D12/101
- D667,757 S * 9/2012 Cooper D12/101
- D710,262 S * 8/2014 Faye D12/101

(Continued)

Primary Examiner — Katrina A Betton

(74) *Attorney, Agent, or Firm* — Whyte Hirschboeck Dudek S.C.

(57) **CLAIM**

An ornamental design for a modular utility trailer, as shown and described.

DESCRIPTION

FIG. 1 is a perspective view for a modular utility trailer in accordance with a first embodiment of the design;
 FIG. 2 is a perspective exploded view thereof;
 FIG. 3 is a front perspective view thereof;
 FIG. 4 is a rear perspective view thereof;
 FIG. 5 is a top view thereof;
 FIG. 6 is a bottom view thereof;
 FIG. 7 is a right view thereof;
 FIG. 8 is a left view thereof;
 FIG. 9 is a front view thereof;
 FIG. 10 is a back view thereof;
 FIG. 11 is a perspective view of the modular utility trailer including a leaf bag;
 FIG. 12 is a front perspective view for a modular utility trailer in accordance with a second embodiment of the design;
 FIG. 13 is a rear perspective view thereof;
 FIG. 14 is a top view thereof;
 FIG. 15 is a bottom view thereof;
 FIG. 16 is a right view thereof;
 FIG. 17 is a left view thereof;
 FIG. 18 is a front view thereof;
 FIG. 19 is a back view thereof;
 FIG. 20 shows the first embodiment of the design configured for shipping; and,
 FIG. 21 is an exploded view thereof.
 The broken lines form no part of the claimed design.

1 Claim, 12 Drawing Sheets

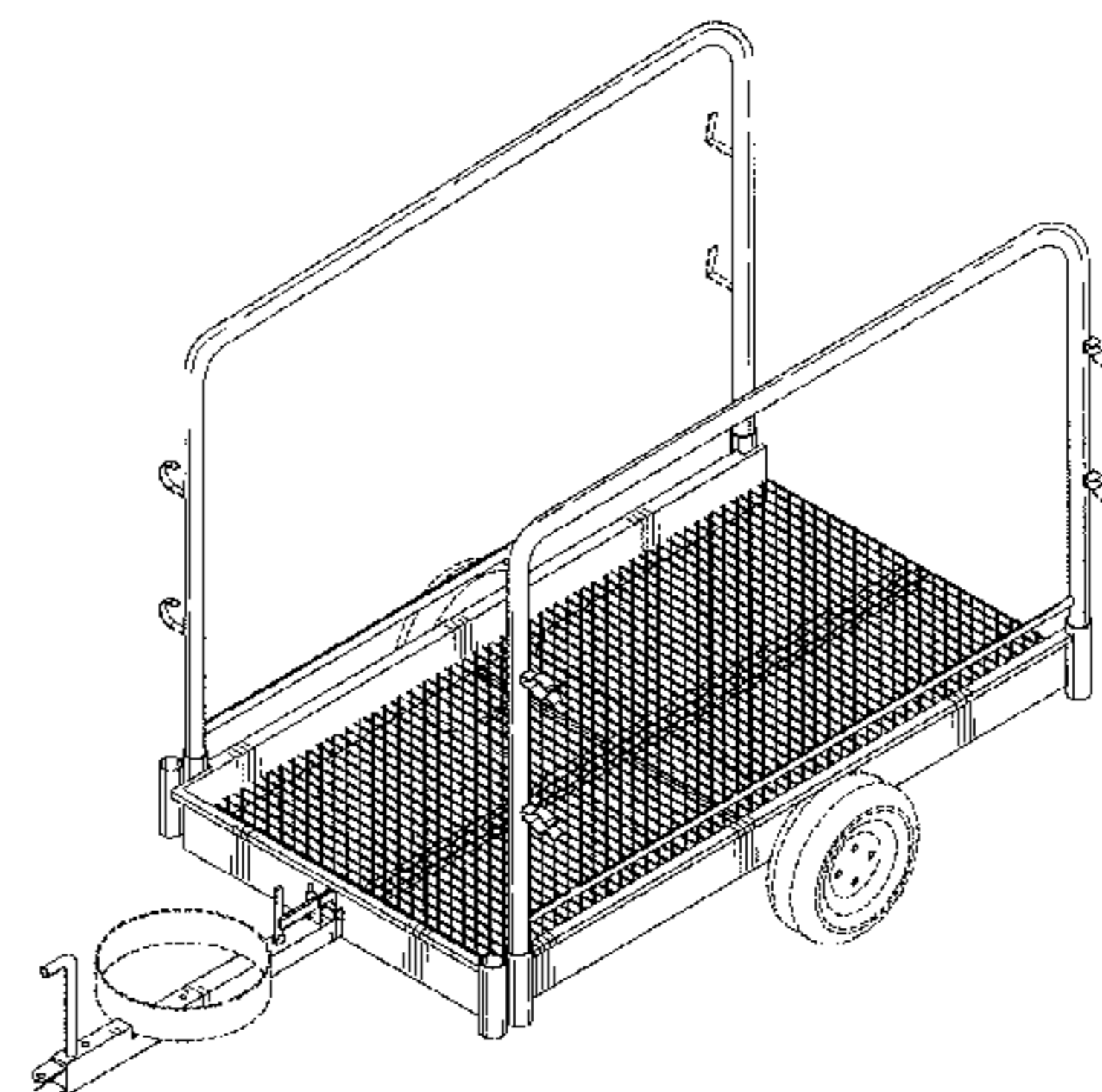
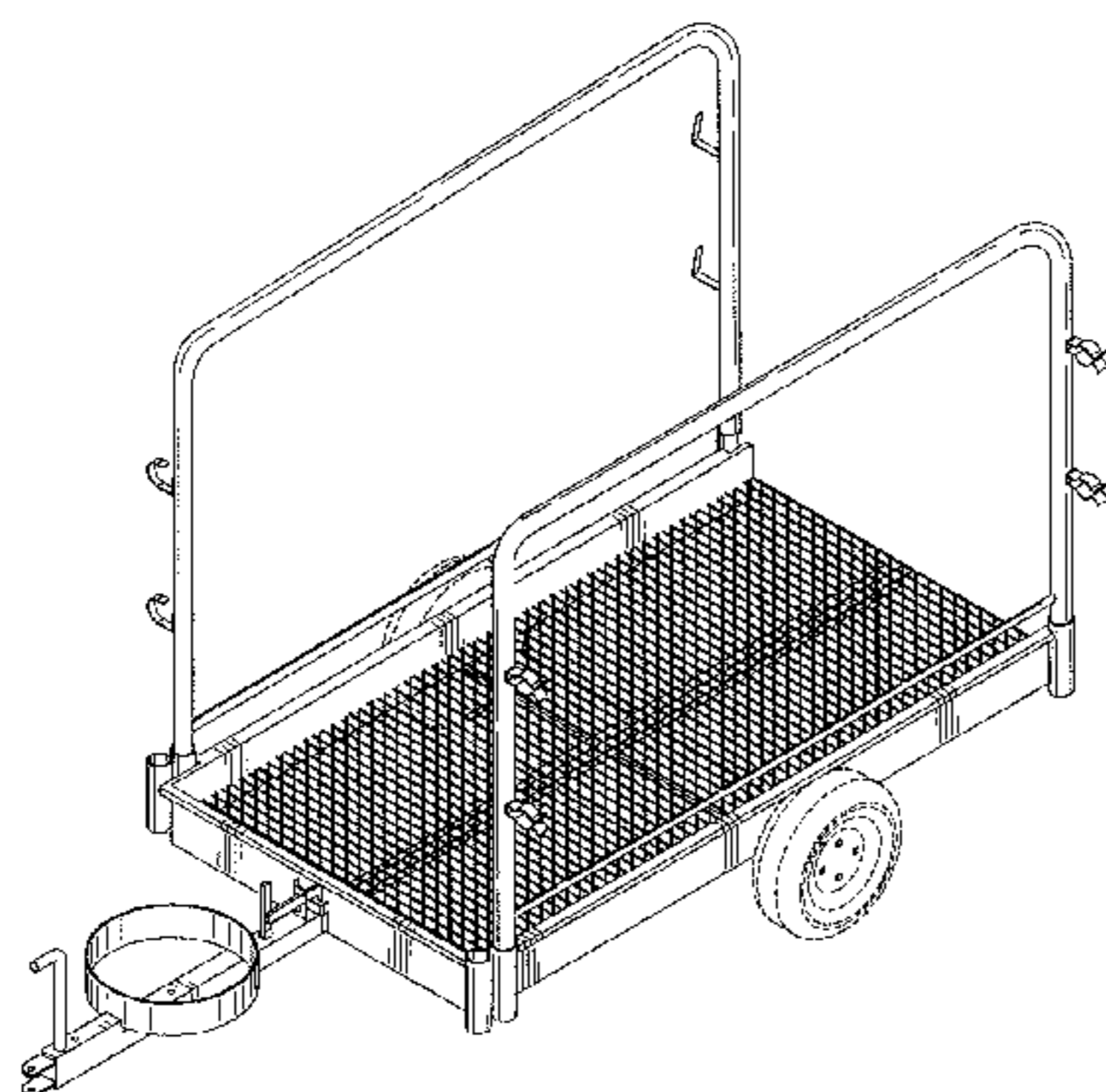

US D761,160 S

Page 2

(56)

References Cited

U.S. PATENT DOCUMENTS

D733,005 S * 6/2015 Erwin D12/101
D751,466 S * 3/2016 Freitag D12/101

2003/0222431 A1 12/2003 Crosby et al.
2004/0049960 A1* 3/2004 Percy G06Q 30/0242
40/590
2009/0212515 A1 8/2009 Oyasaeter

* cited by examiner

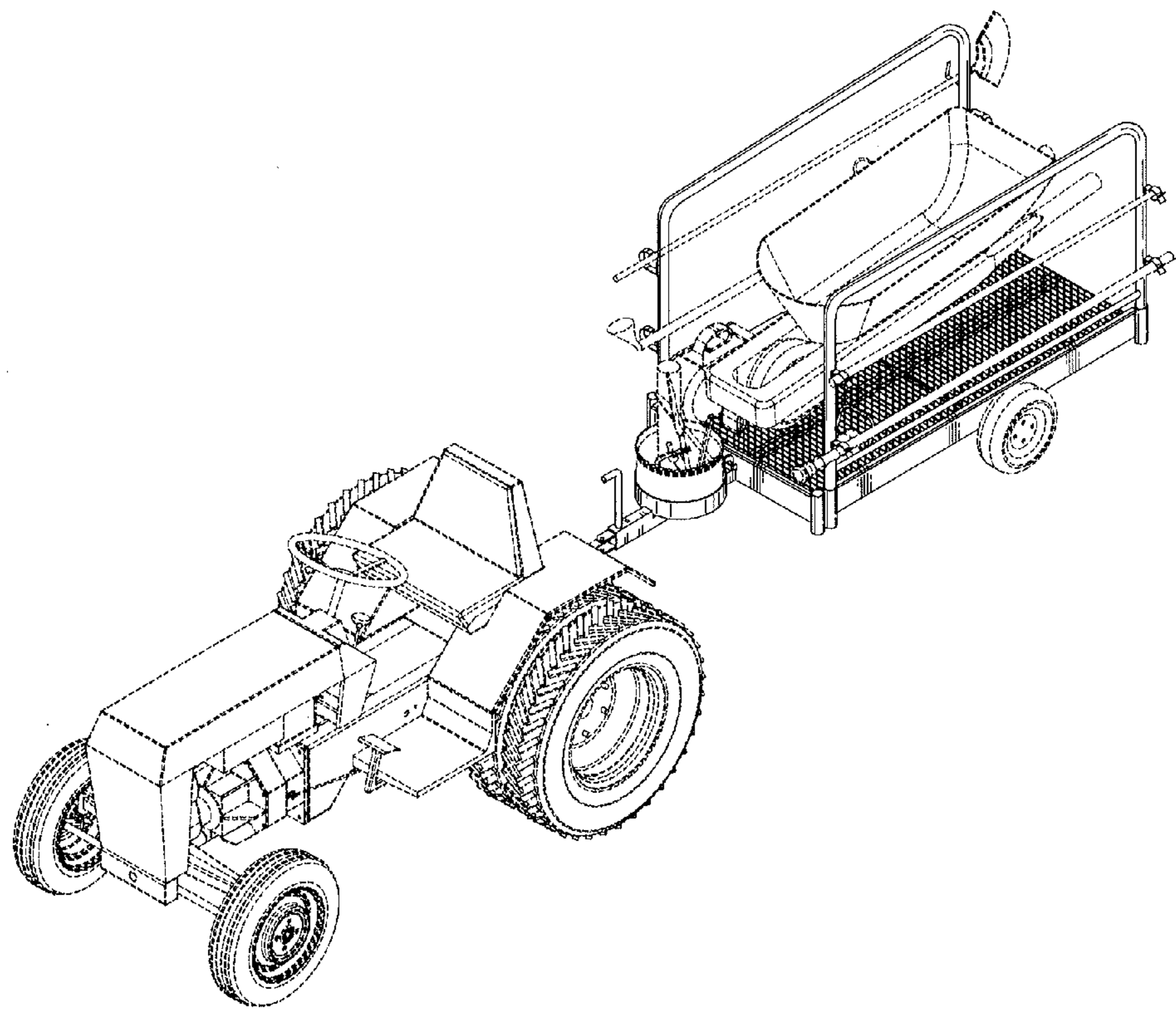

FIG. 1

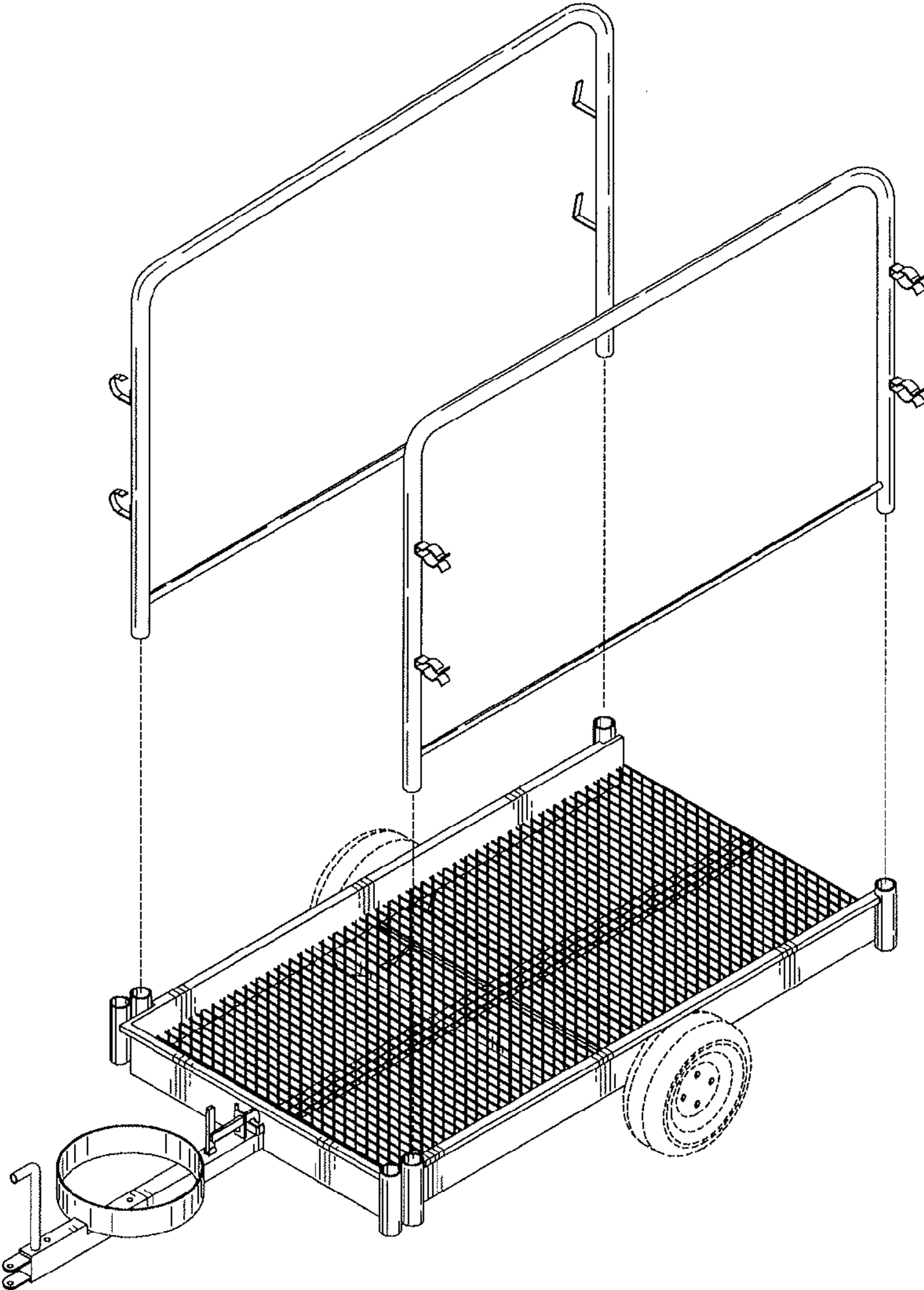

FIG. 2

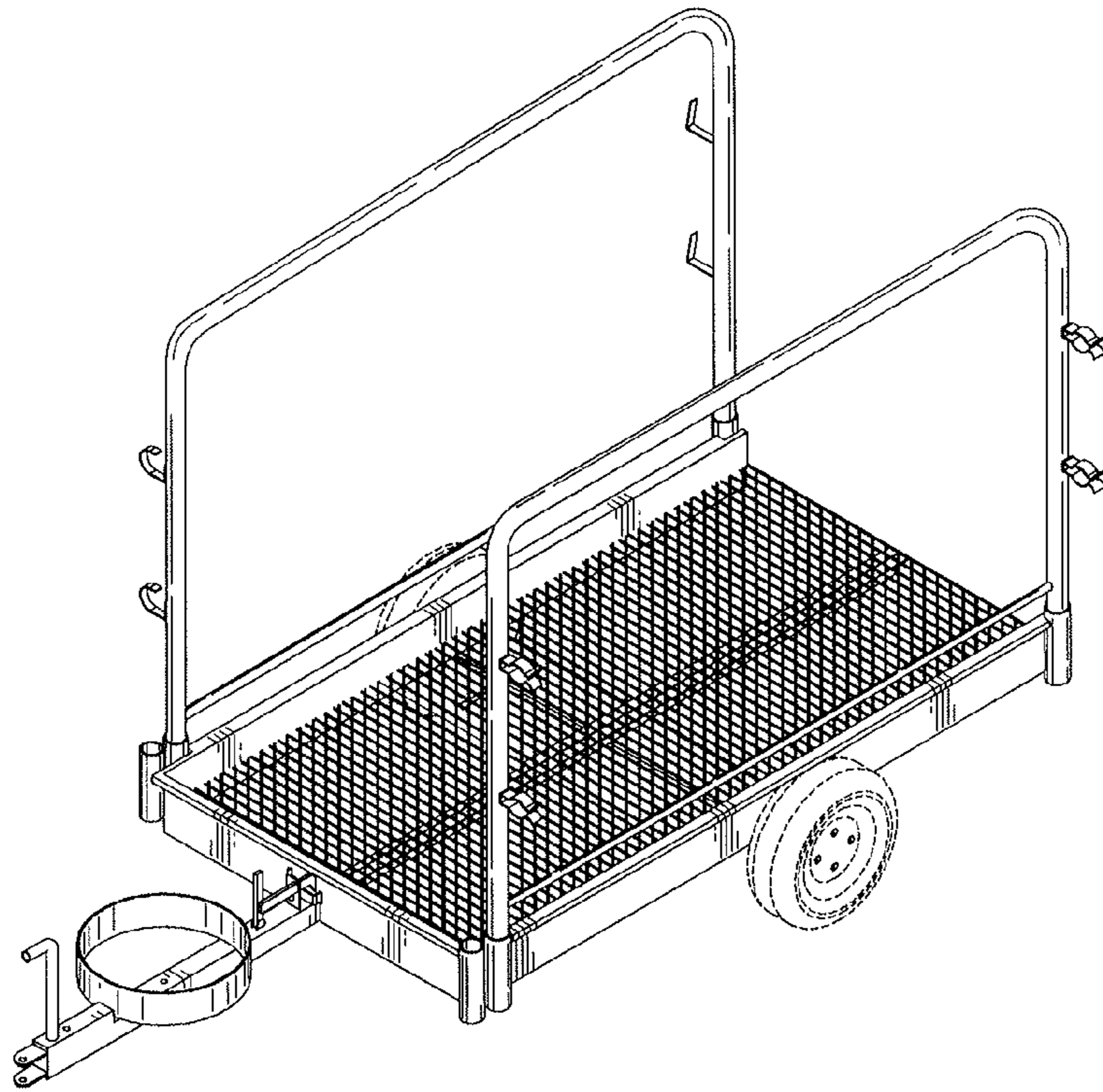

FIG. 3

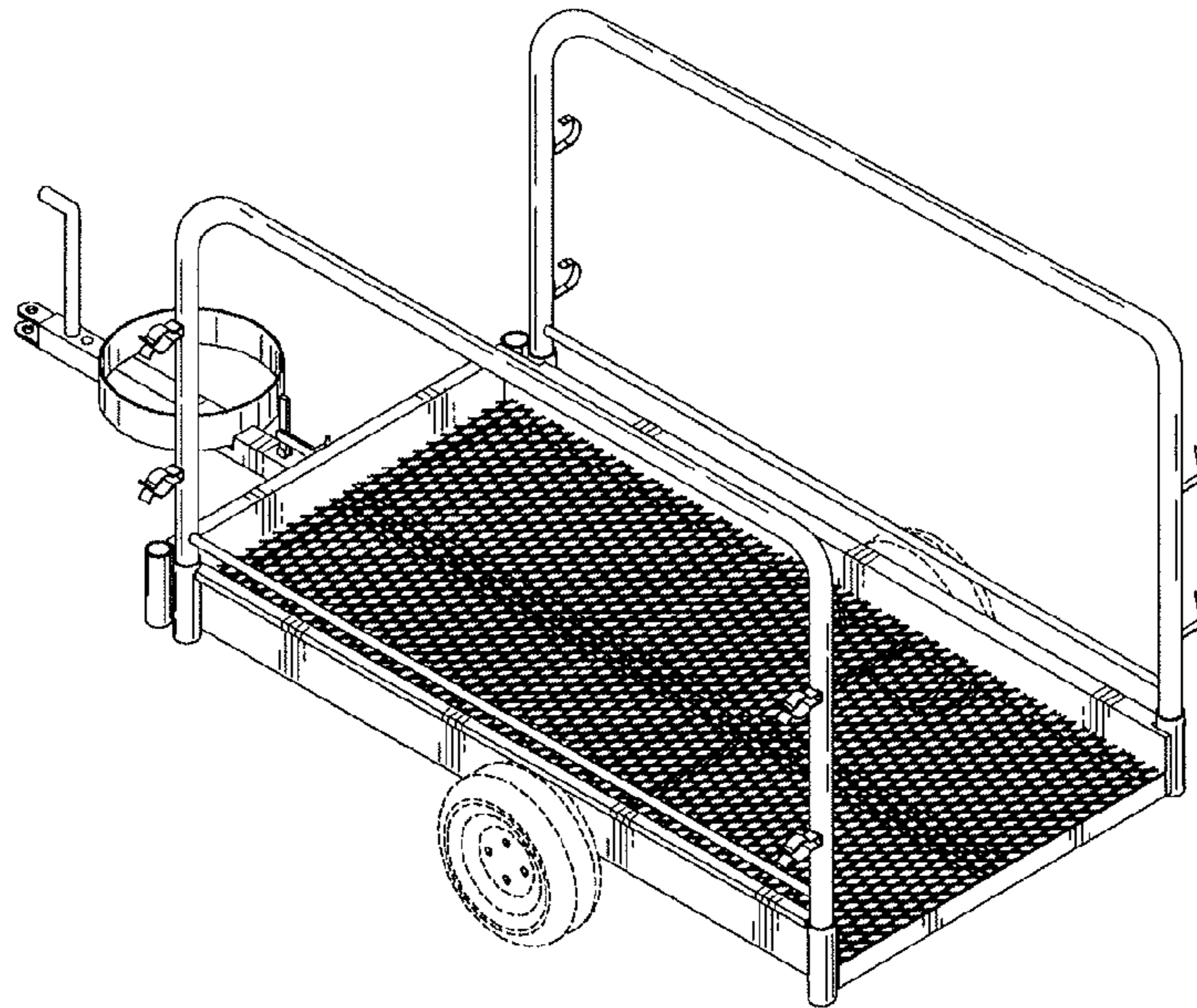

FIG. 4

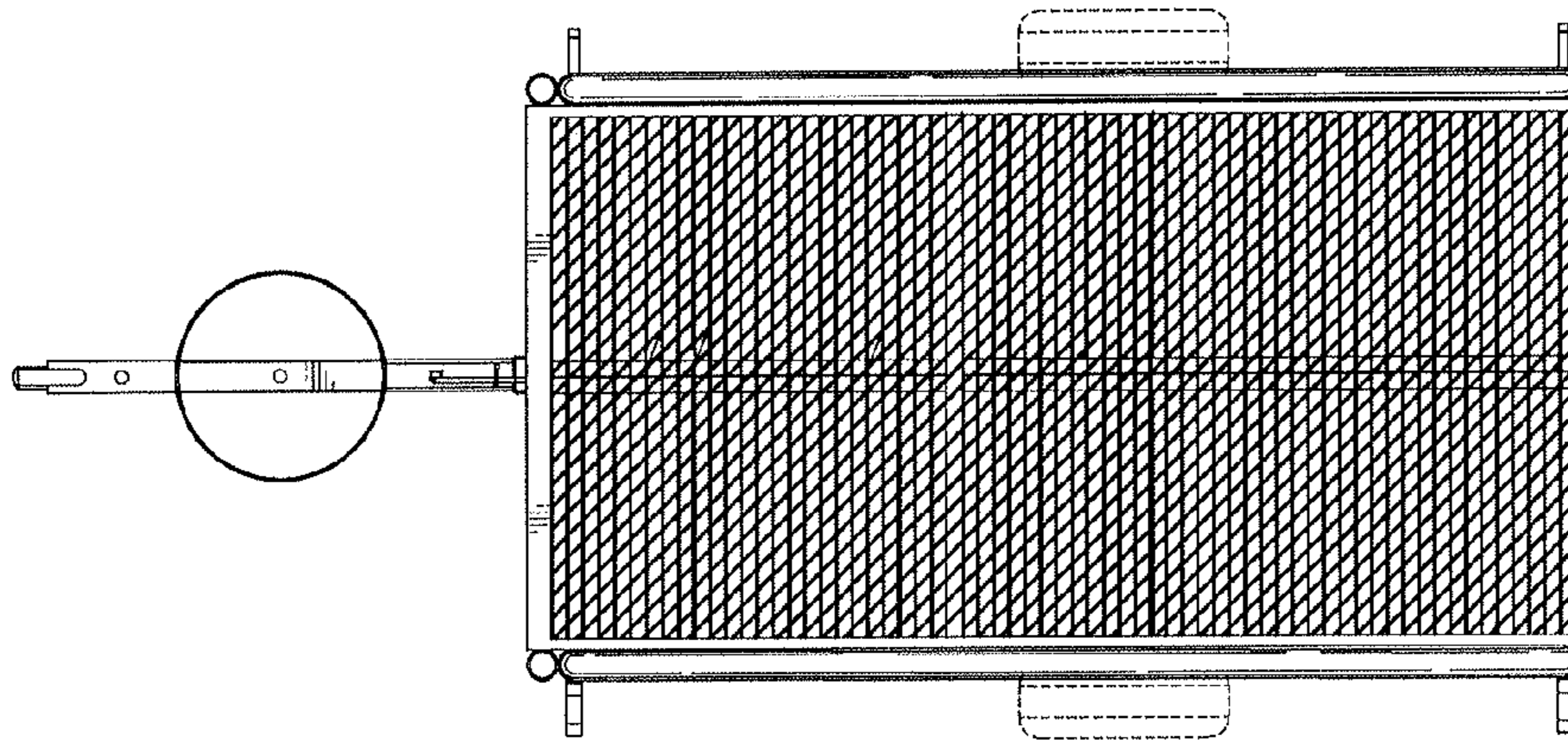

FIG. 5

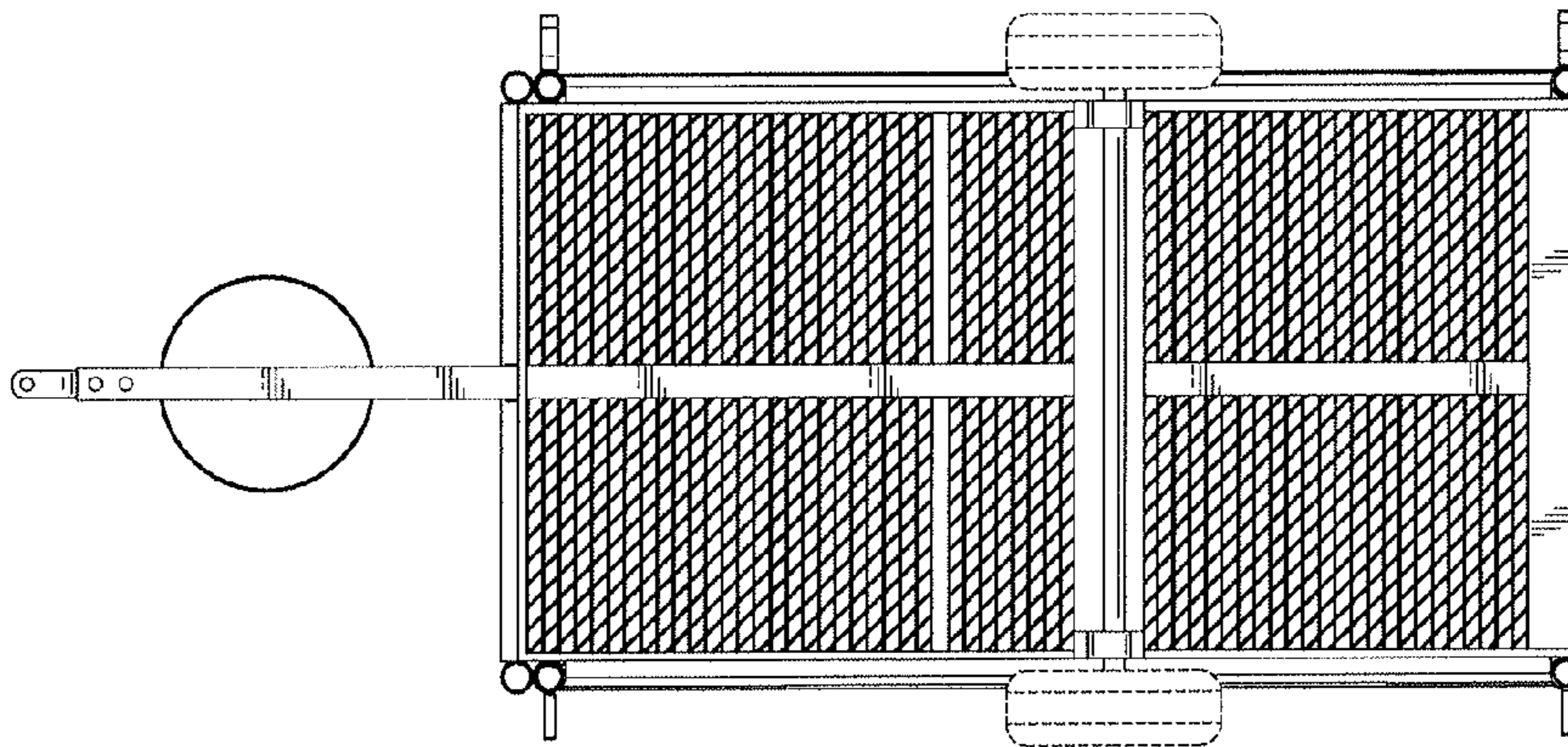

FIG. 6

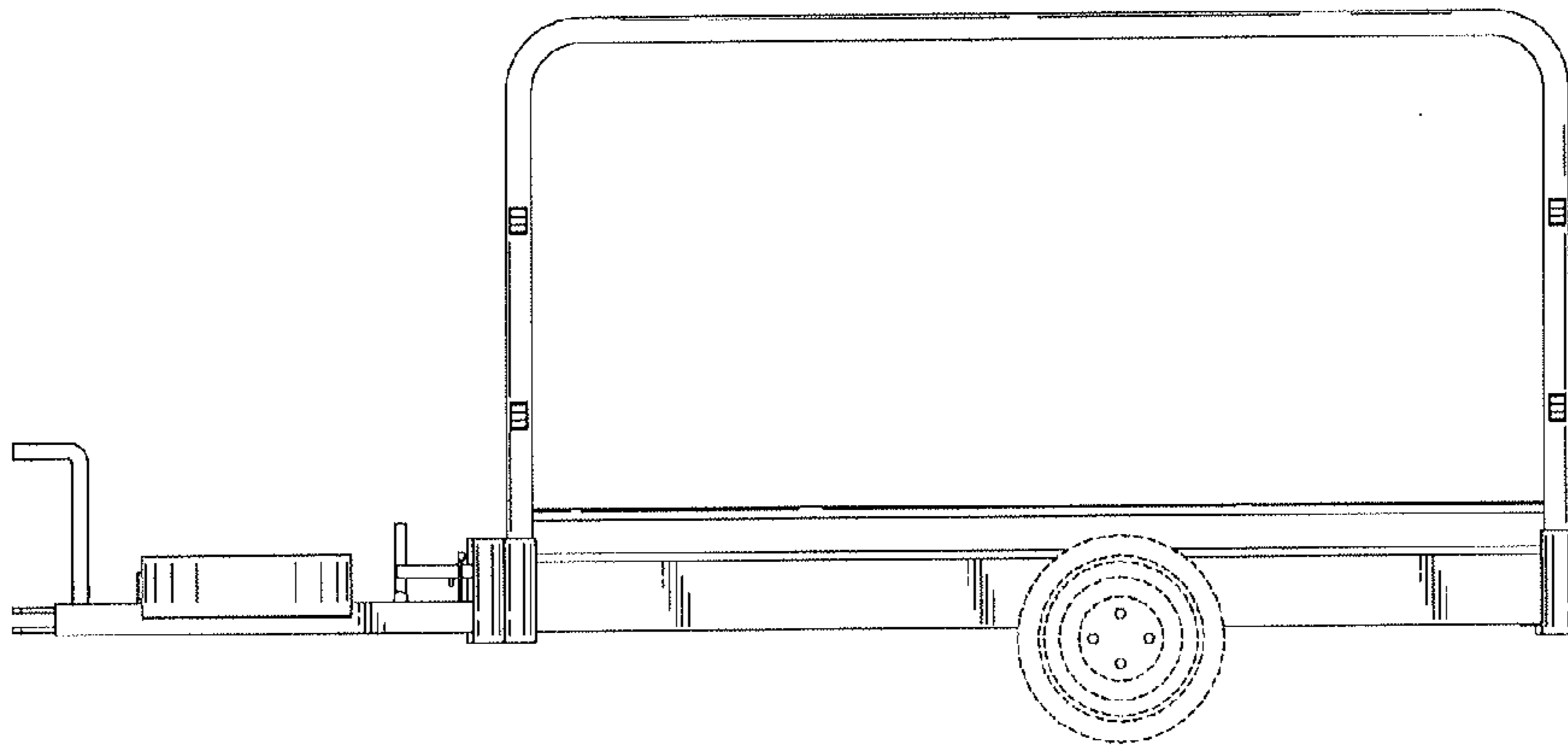

FIG. 7

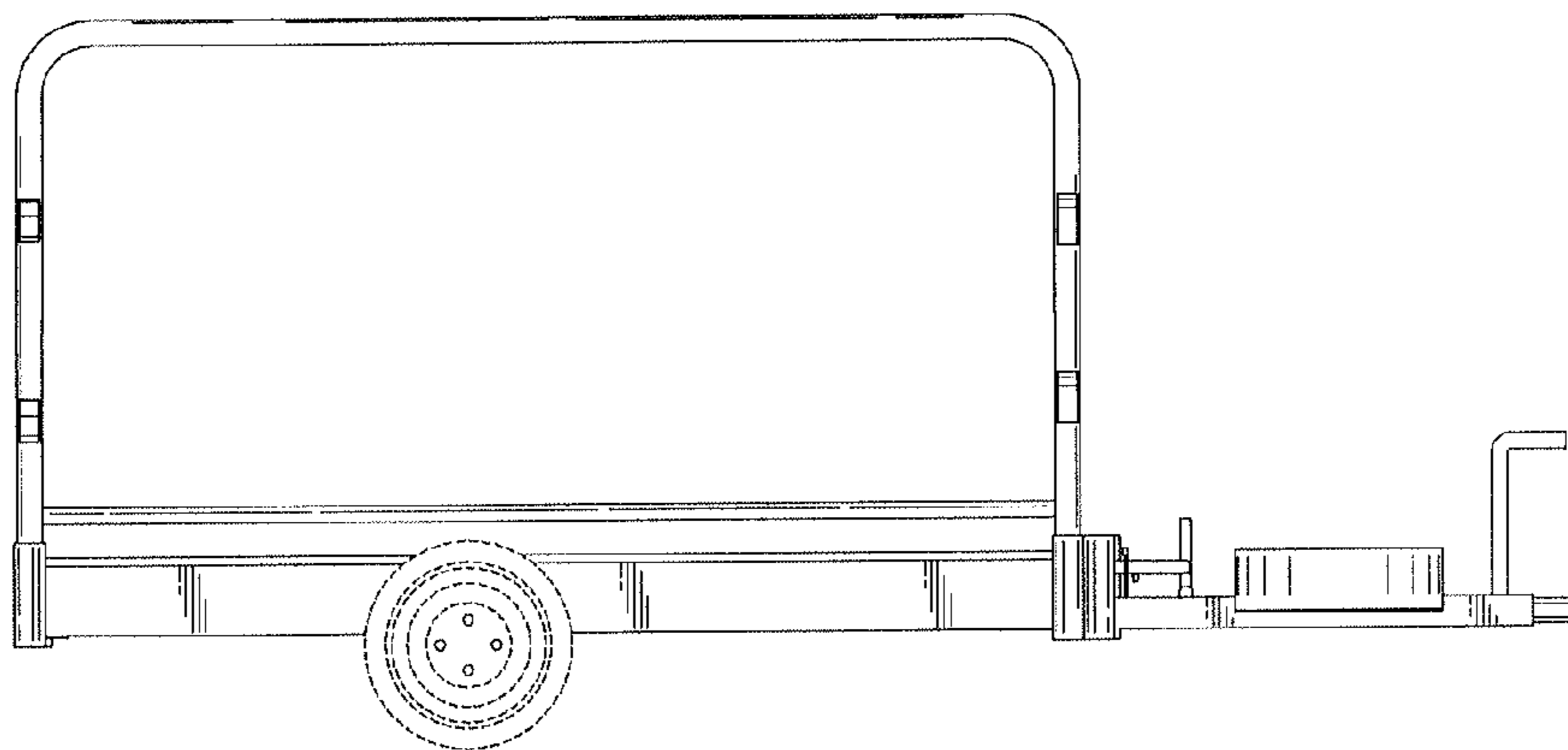

FIG. 8

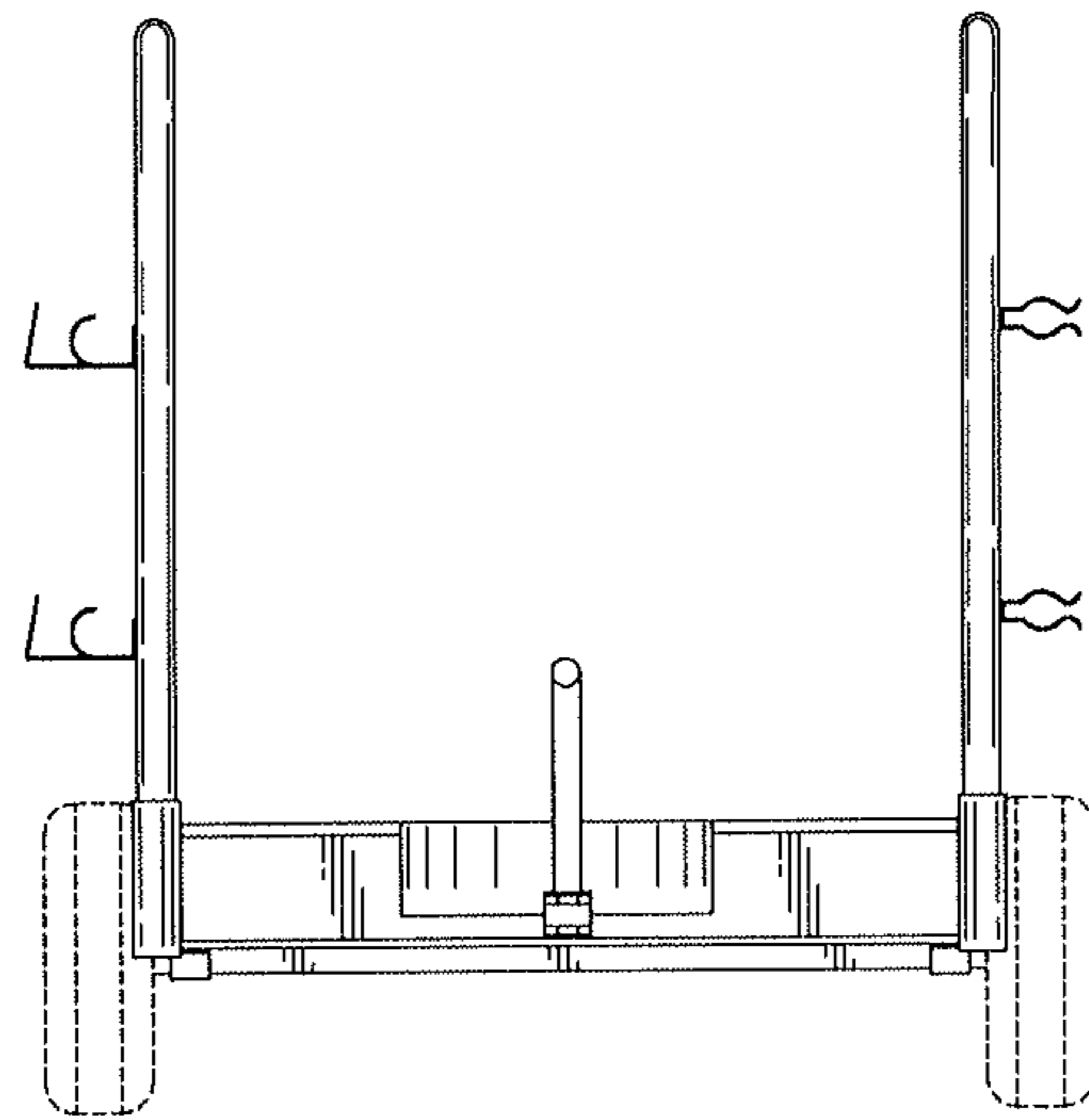

FIG. 9

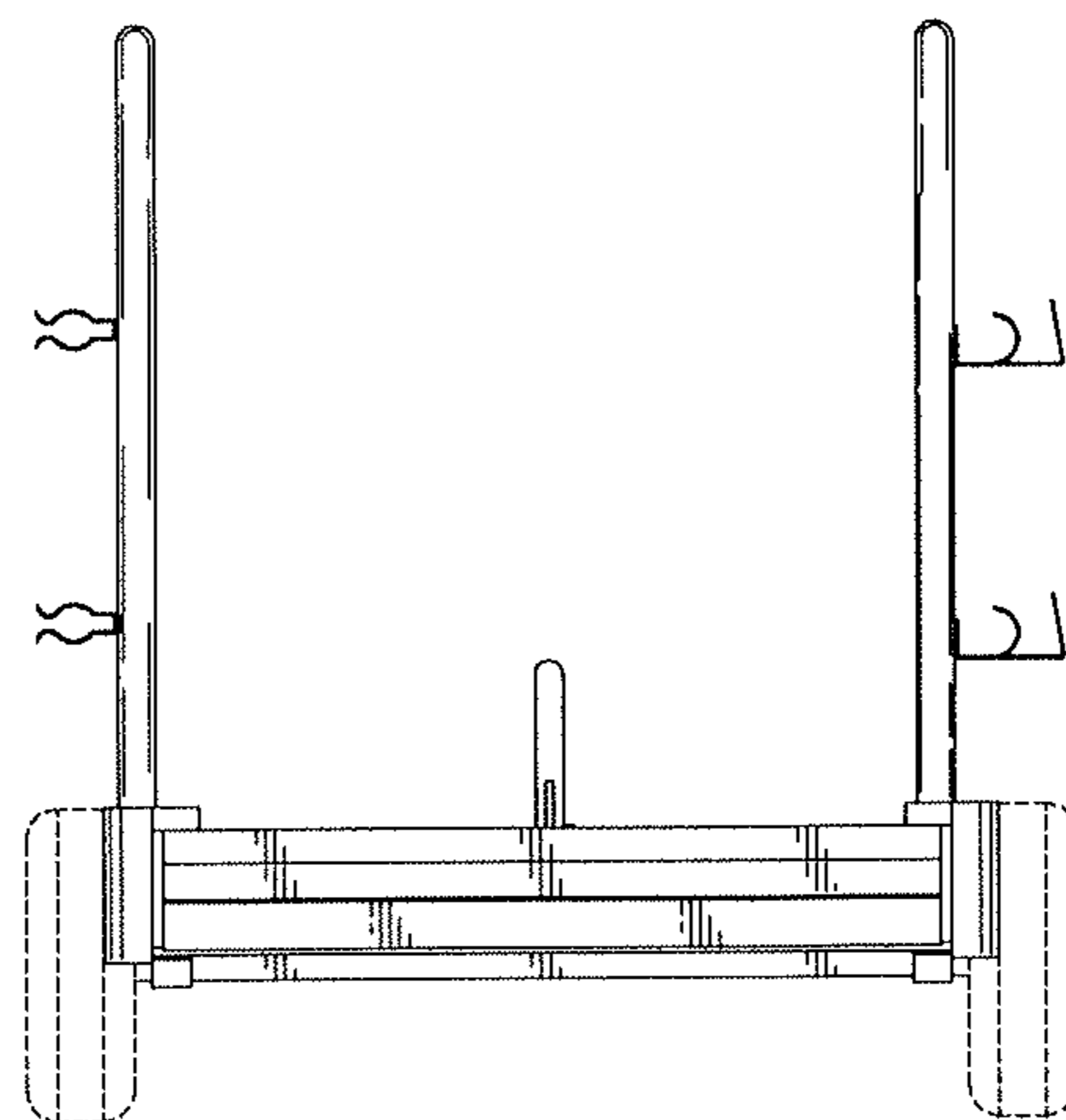

FIG. 10

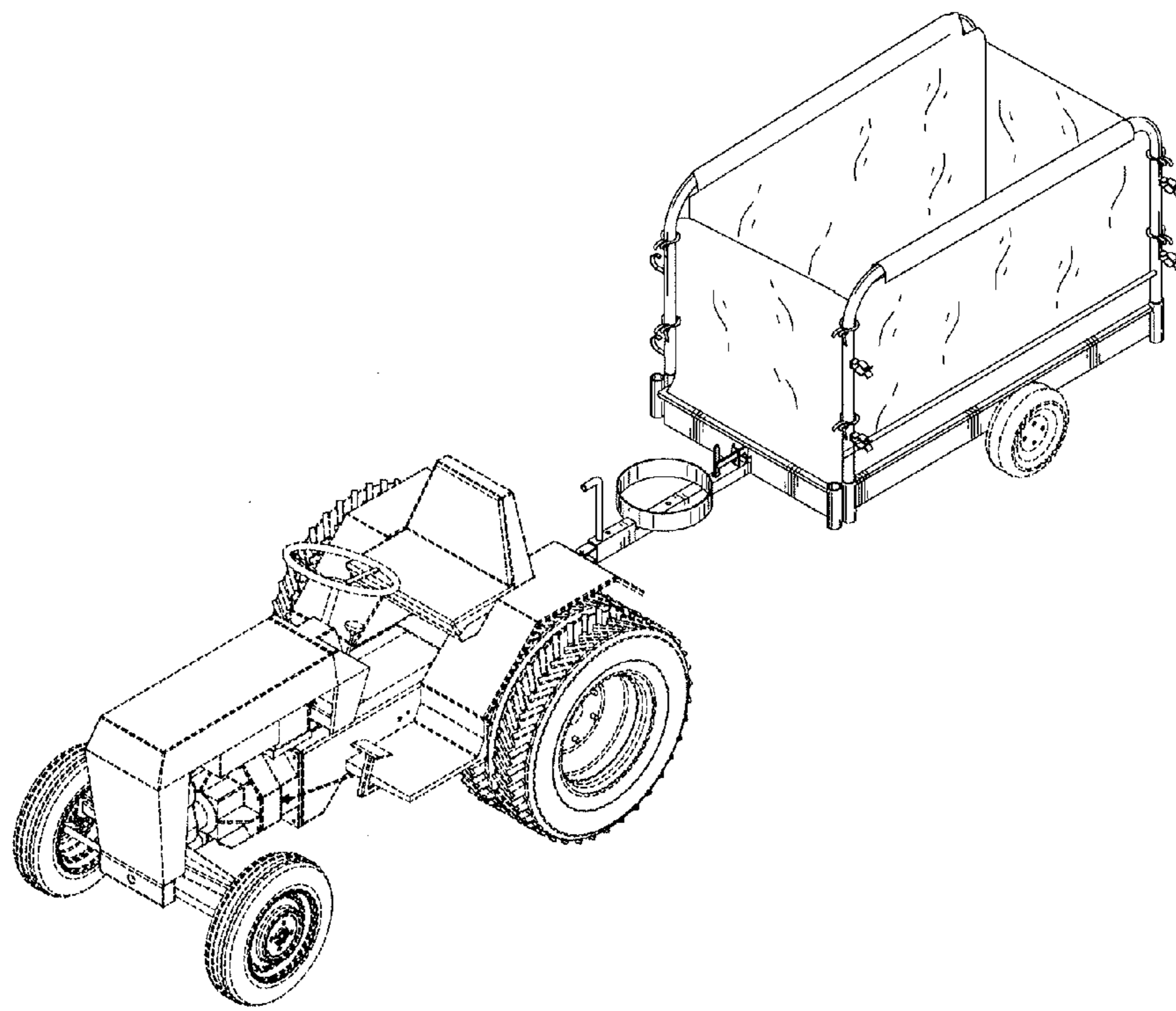

FIG. 11

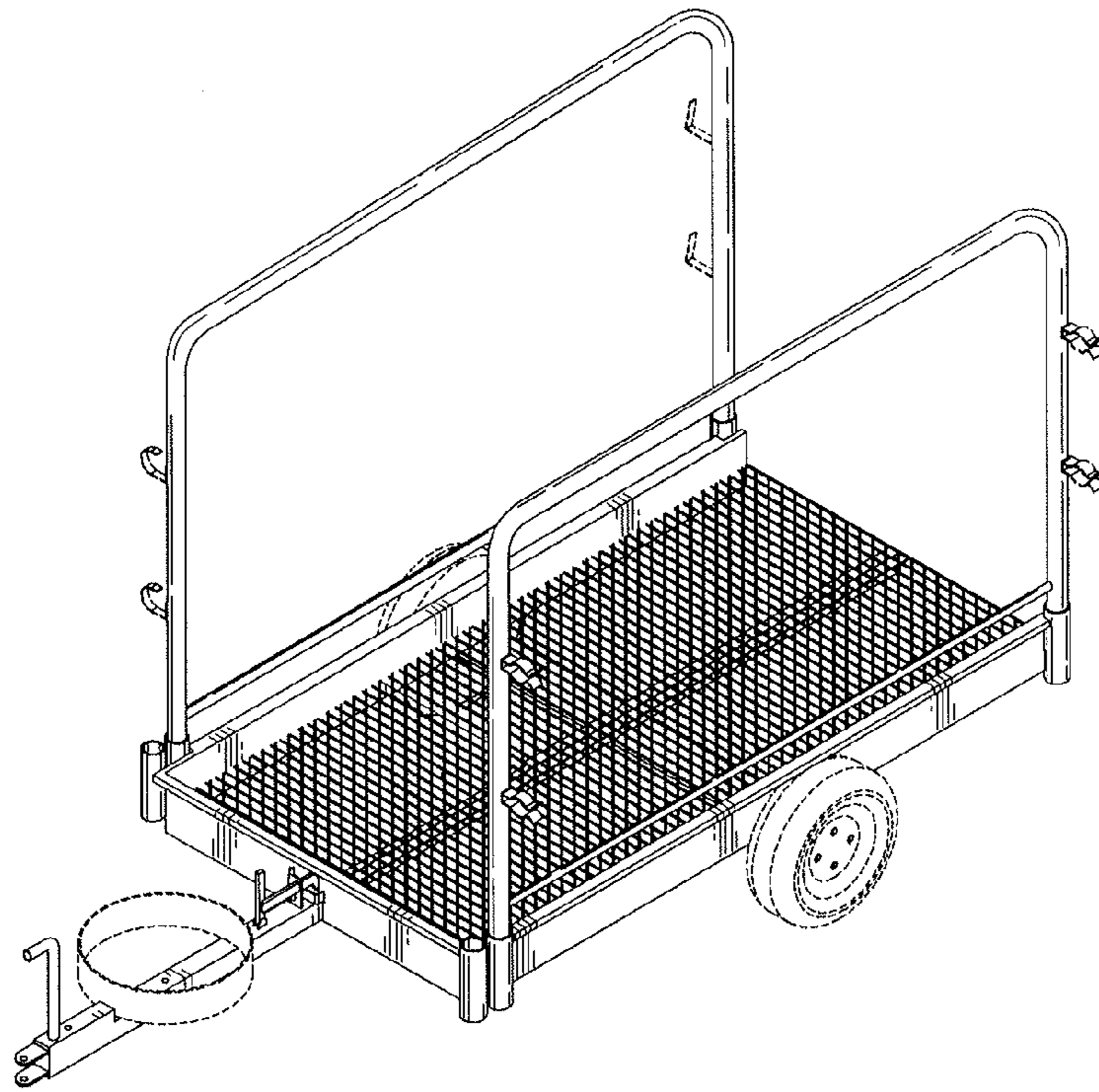

FIG. 12

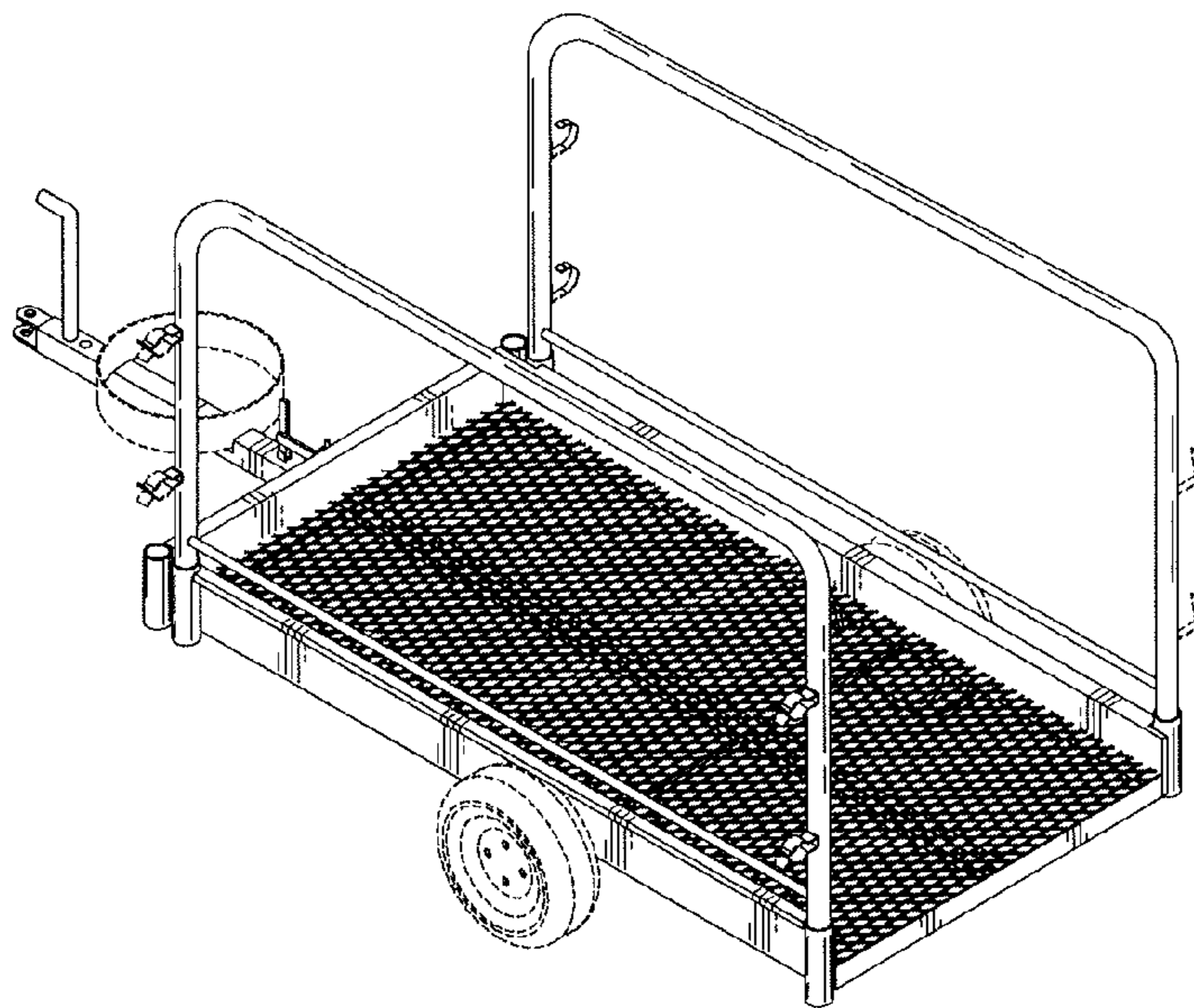

FIG. 13

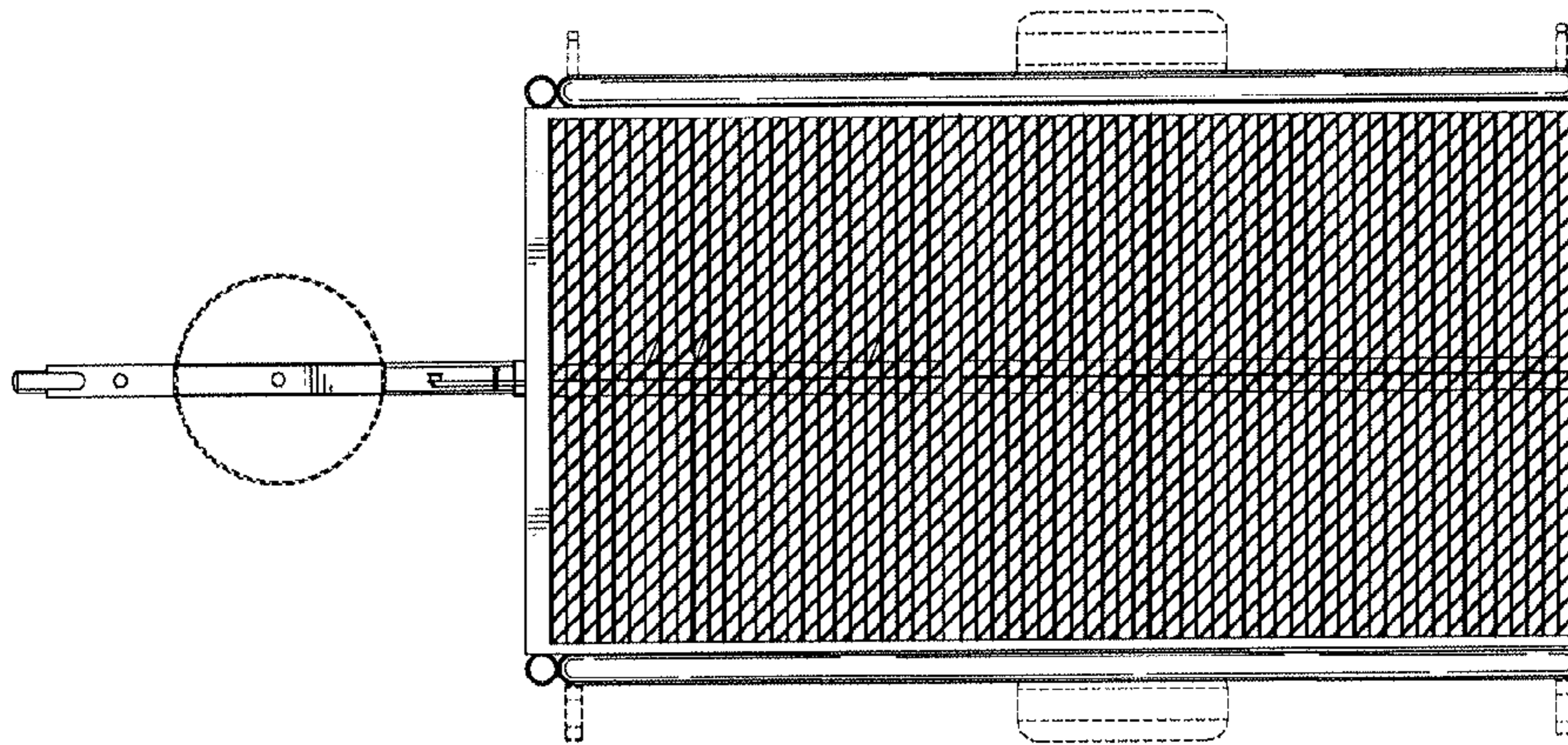

FIG. 14

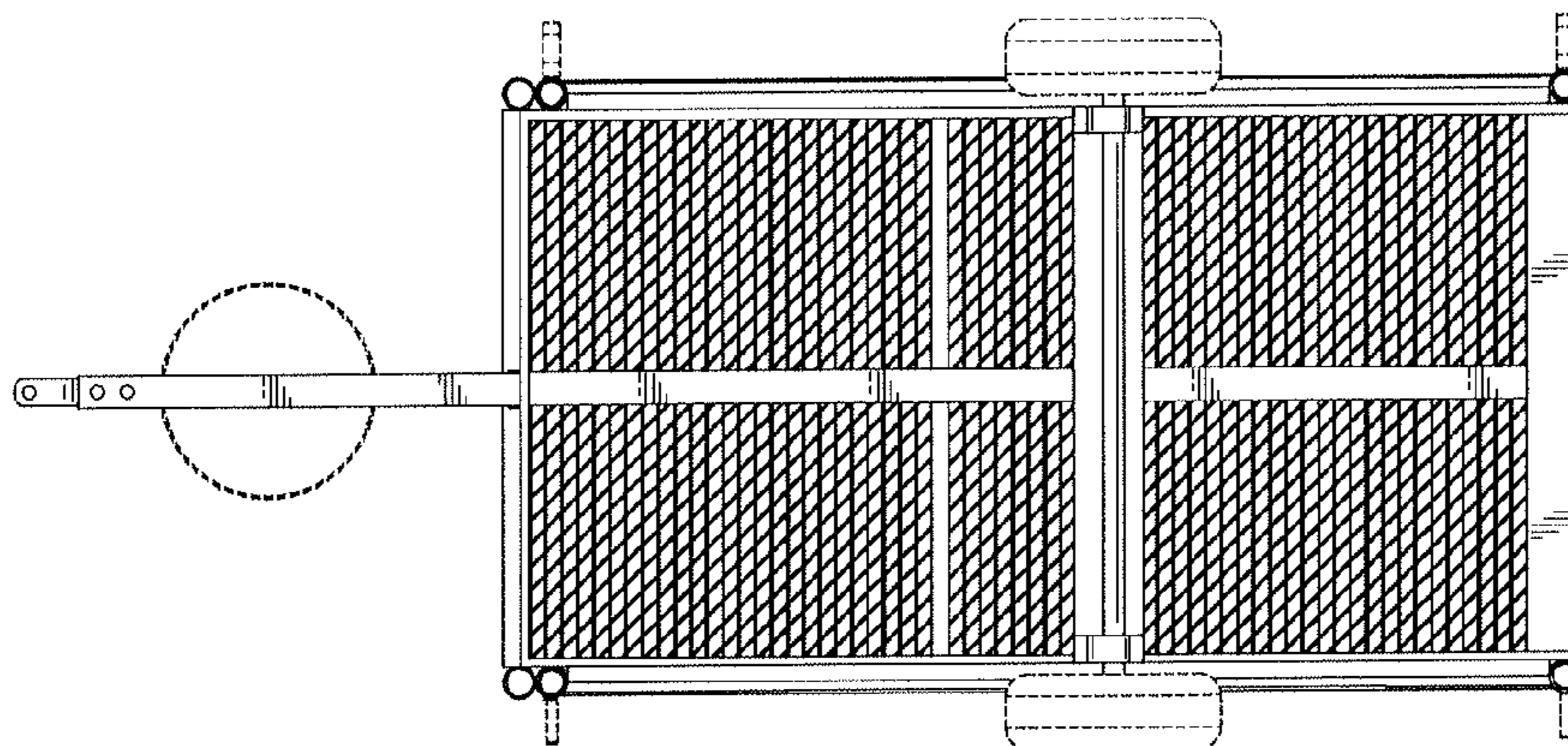

FIG. 15

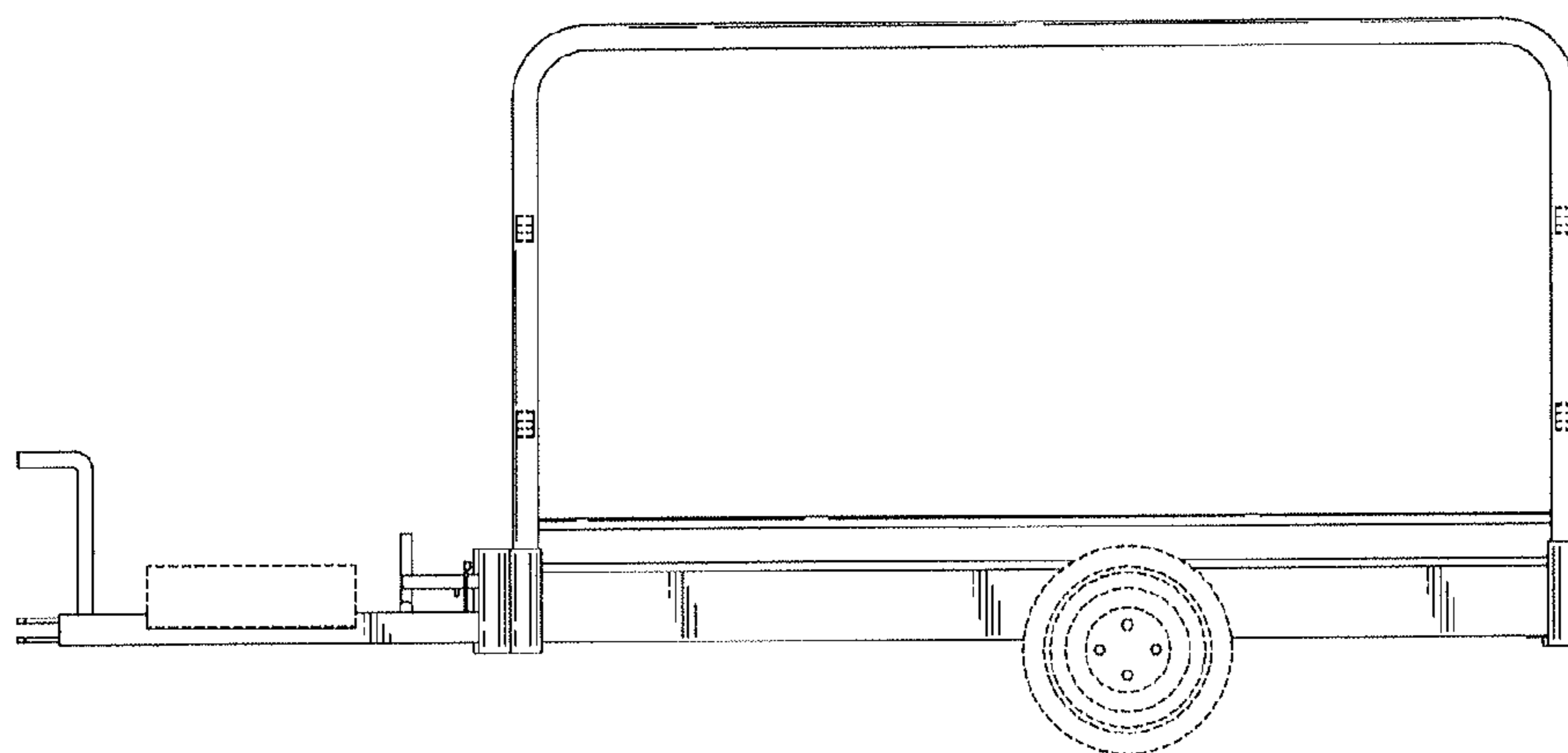

FIG. 16

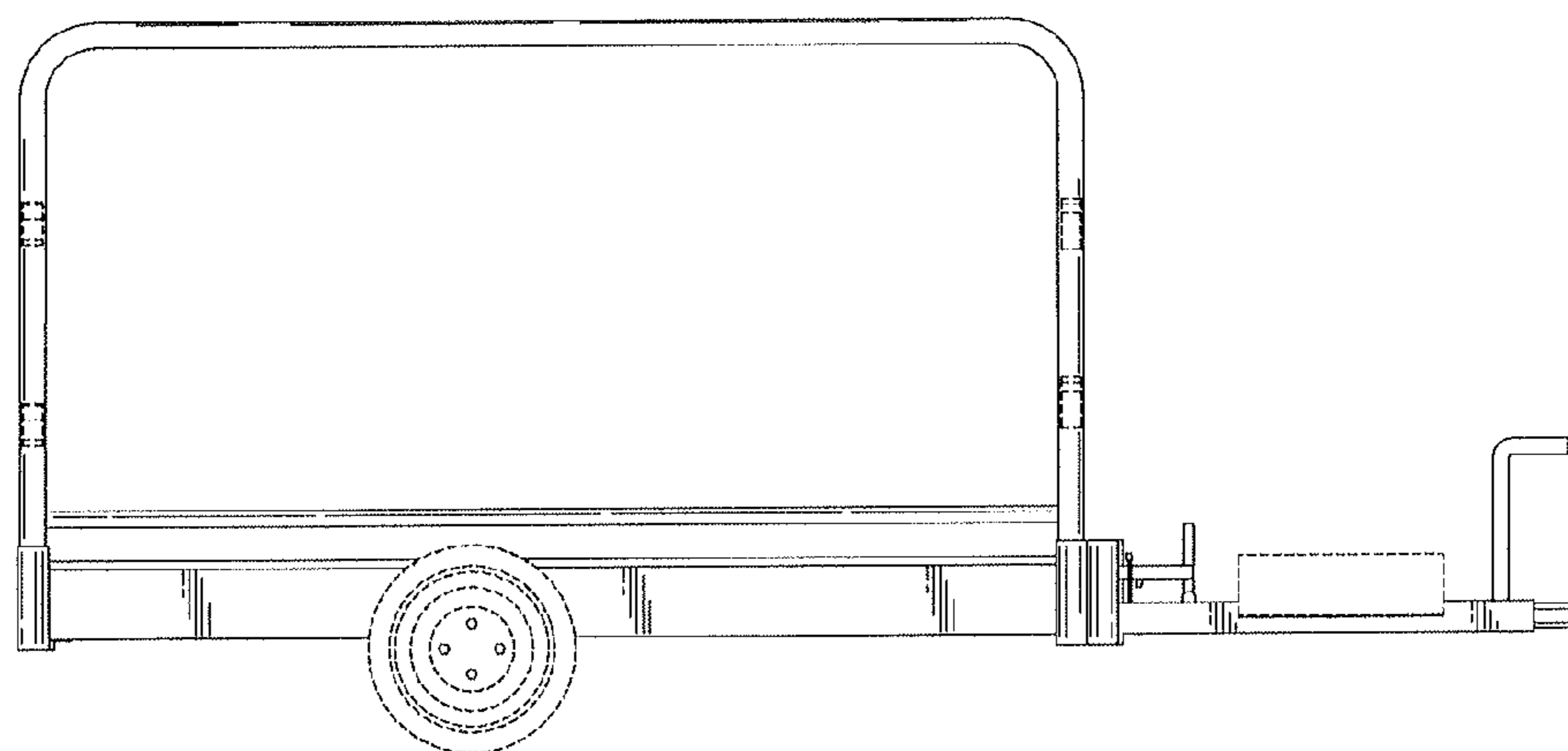

FIG. 17

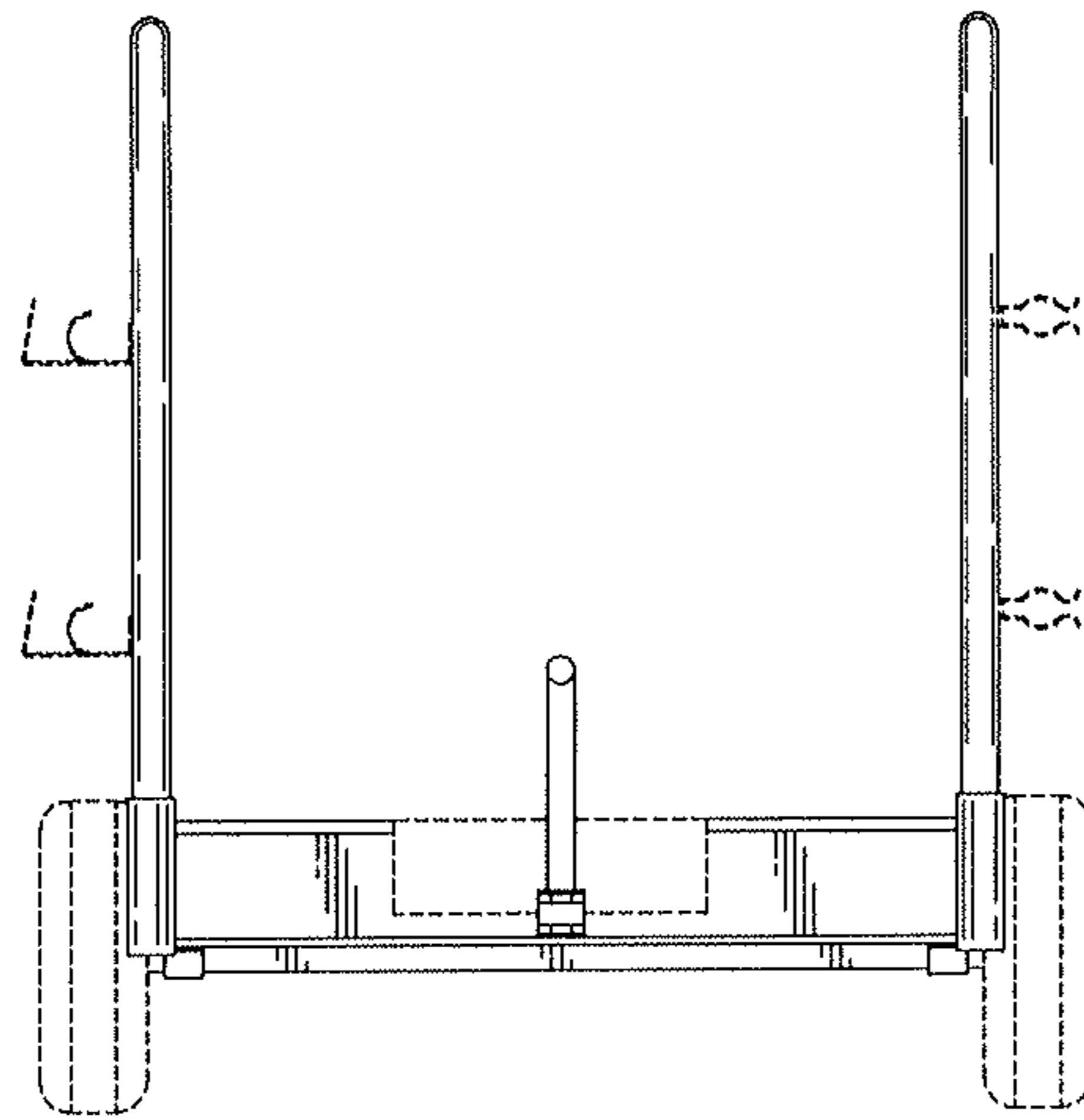

FIG. 18

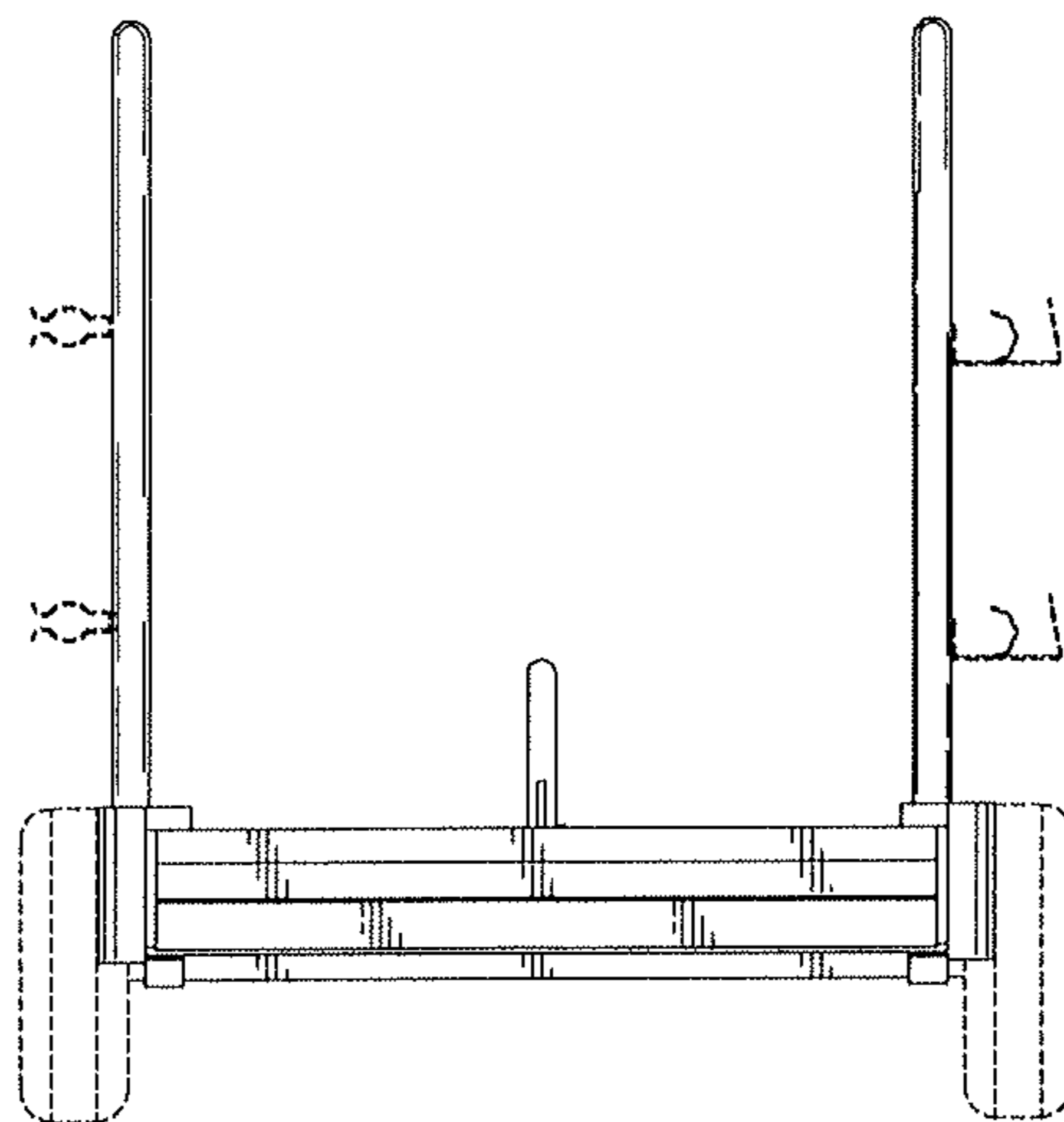

FIG. 19

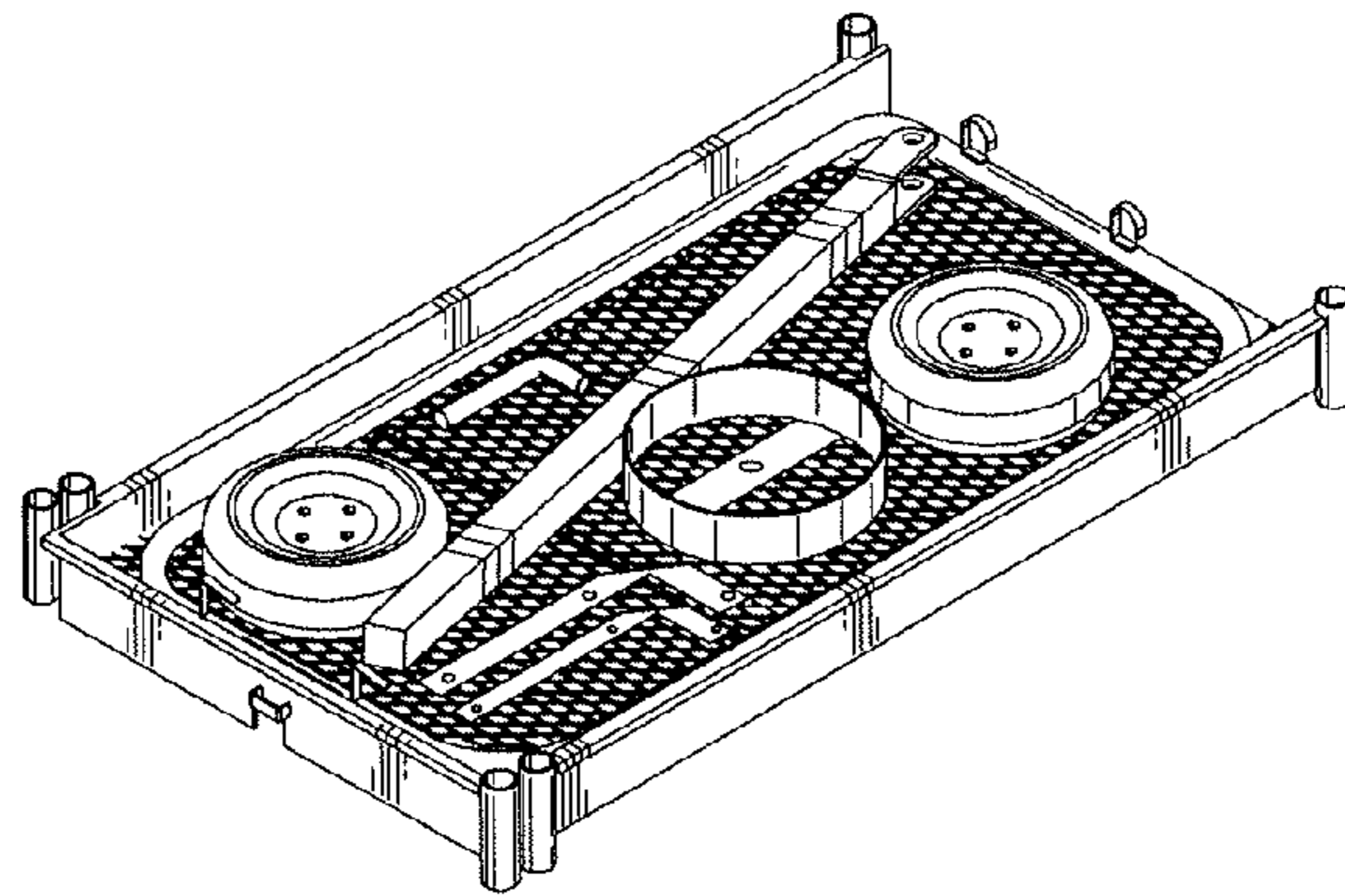

FIG. 20

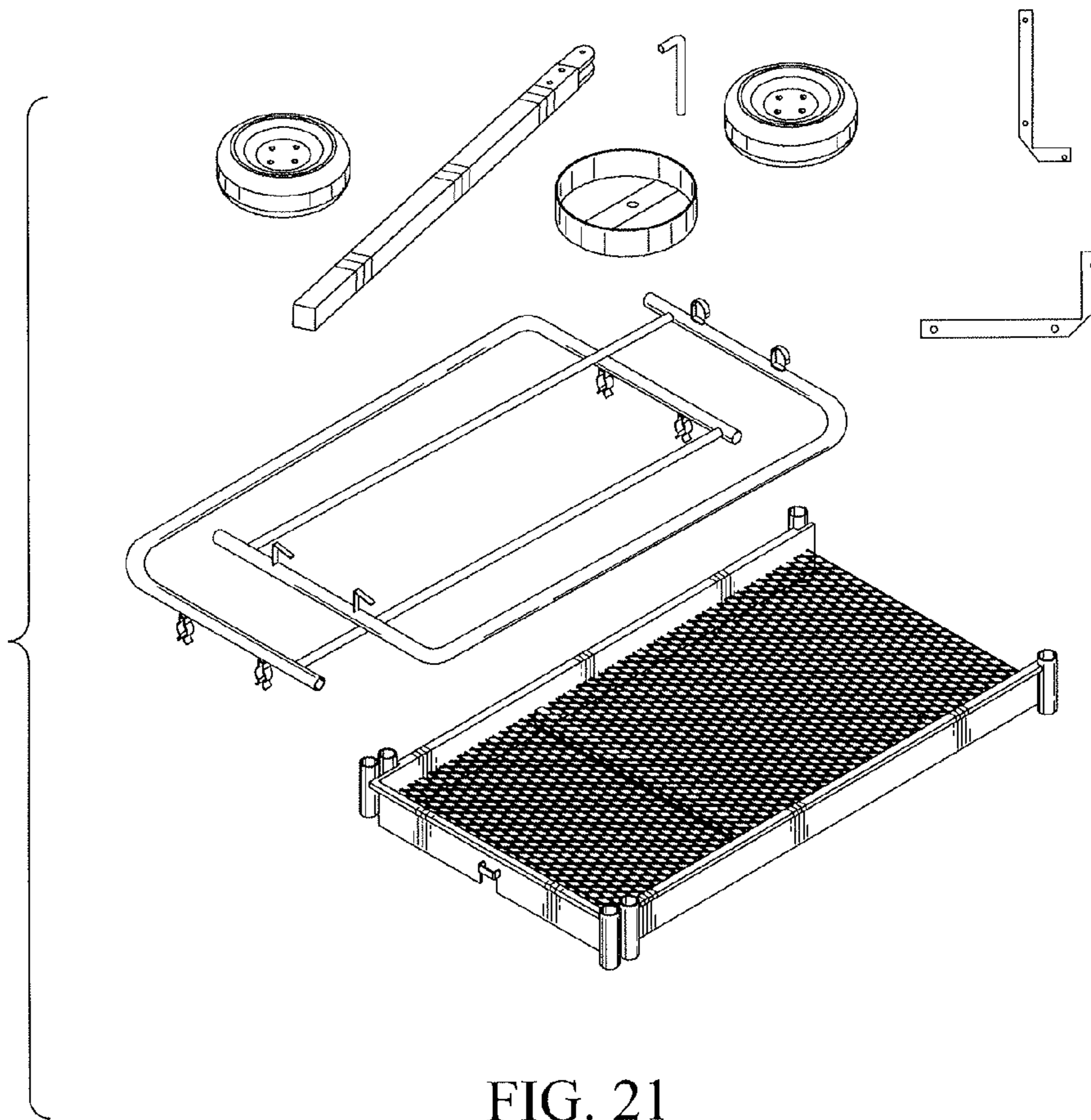

FIG. 21