



US00D760948S

(12) **United States Design Patent**  
**Eksouzian**

(10) **Patent No.:** **US D760,948 S**

(45) **Date of Patent:** **\*\* Jul. 5, 2016**

(54) **VAPORIZER**

(71) Applicant: **Vahan Eksouzian**, Glendale, CA (US)

(72) Inventor: **Vahan Eksouzian**, Glendale, CA (US)

(73) Assignee: **Cloud V Enterprises**, Glendale, CA (US)

(\*\*) Term: **14 Years**

(21) Appl. No.: **29/516,947**

(22) Filed: **Feb. 7, 2015**

(51) **LOC (10) Cl.** ..... **27-01**

(52) **U.S. Cl.**  
USPC ..... **D27/101; D27/163**

(58) **Field of Classification Search**  
USPC ..... D27/101, 162, 163-169, 171; D24/110,  
D24/113; D23/360; 131/329  
CPC ..... A24F 47/00; A24F 47/002; A24F 47/004;  
A24F 47/006; A24F 47/008; F23Q 2/28  
See application file for complete search history.

(56) **References Cited**

**U.S. PATENT DOCUMENTS**

D653,803 S *	2/2012	Timmermans	.....	D27/163
D720,095 S *	12/2014	Alima	.....	D27/101
D720,881 S *	1/2015	Liu	.....	D27/101
D721,202 S *	1/2015	Liu	.....	D27/101
D725,310 S *	3/2015	Eksouzian	.....	D27/101
D727,566 S *	4/2015	Xiao	.....	D27/101
D748,853 S *	2/2016	Seibel	.....	D27/101
2010/0031968 A1 *	2/2010	Sheikh	.....	A24F 47/008 131/347
2013/0068239 A1 *	3/2013	Youn	.....	A24F 47/008 131/273
2014/0041655 A1 *	2/2014	Barron	.....	A61M 11/042 128/202.21

\* cited by examiner

*Primary Examiner* — Susan Bennett Hattan

*Assistant Examiner* — Janice Hallmark

(57) **CLAIM**

The ornamental design for a vaporizer, shown and described.

**DESCRIPTION**

FIG. 1 is a perspective view of a vaporizer;  
 FIG. 2 is a front view of the vaporizer;  
 FIG. 3 is a side view of the vaporizer;  
 FIG. 4 is a rear view of the vaporizer;  
 FIG. 5 is a front view of the vaporizer shown for clarity of disclosure with the mouthpiece of the vaporizer shown for clarity of disclosure separated from the body of the vaporizer shown for clarity of disclosure;  
 FIG. 6 is a side view of the vaporizer shown for clarity of disclosure with the mouthpiece of the vaporizer shown for clarity of disclosure separated from the body of the vaporizer shown for clarity of disclosure;  
 FIGS. 7 and 8 are perspective views of the vaporizer shown for clarity of disclosure with the mouthpiece of the vaporizer shown for clarity of disclosure separated from the body of the vaporizer shown for clarity of disclosure;  
 FIG. 9 is a top view of the mouthpiece of the vaporizer shown for clarity of disclosure;  
 FIG. 10 is a front view of the mouthpiece of the vaporizer shown for clarity of disclosure;  
 FIG. 11 is a side view of the mouthpiece of the vaporizer shown for clarity of disclosure; and,  
 FIG. 12 is a perspective view of the mouthpiece of the vaporizer shown for clarity of disclosure.

**1 Claim, 12 Drawing Sheets**

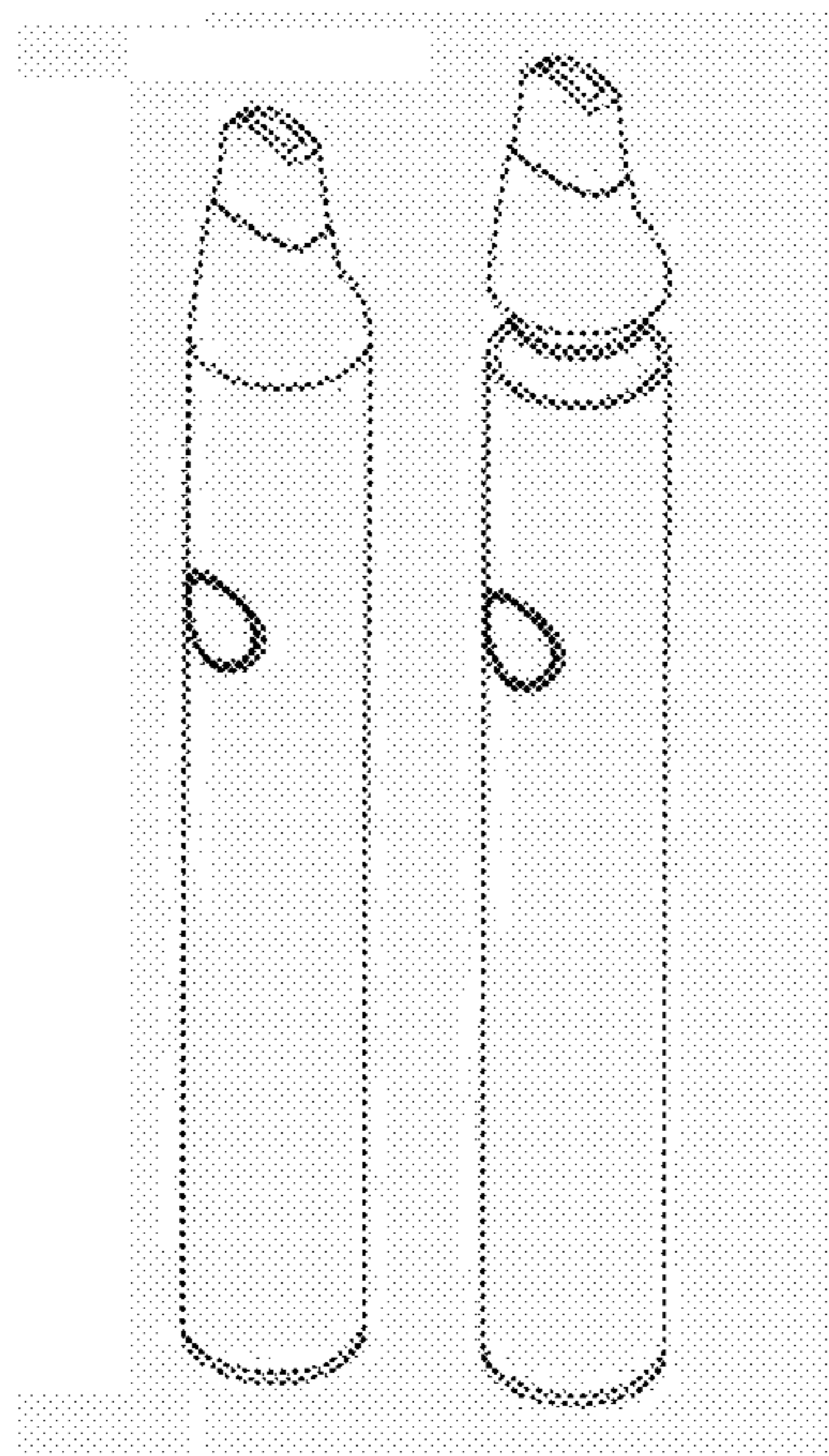

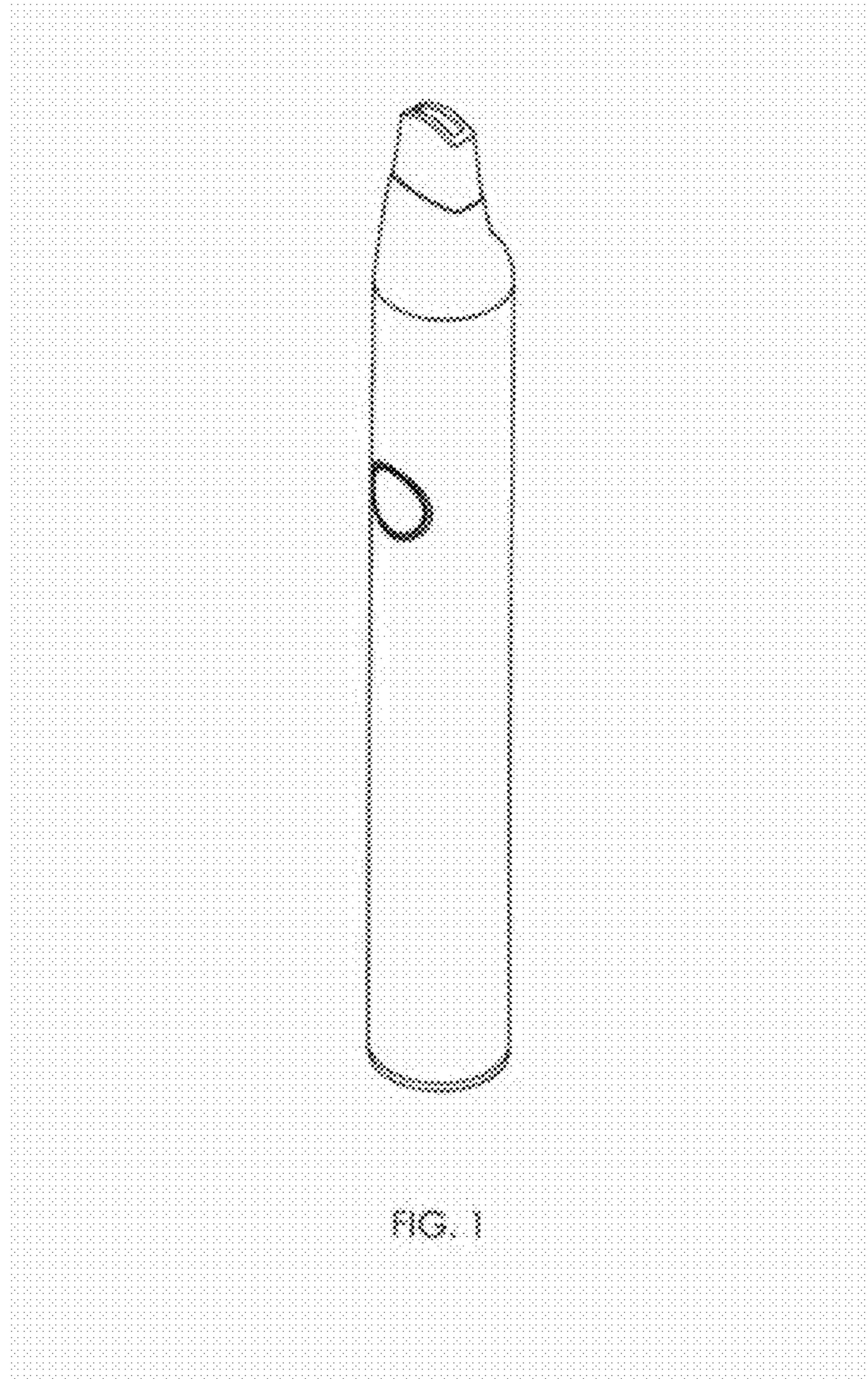
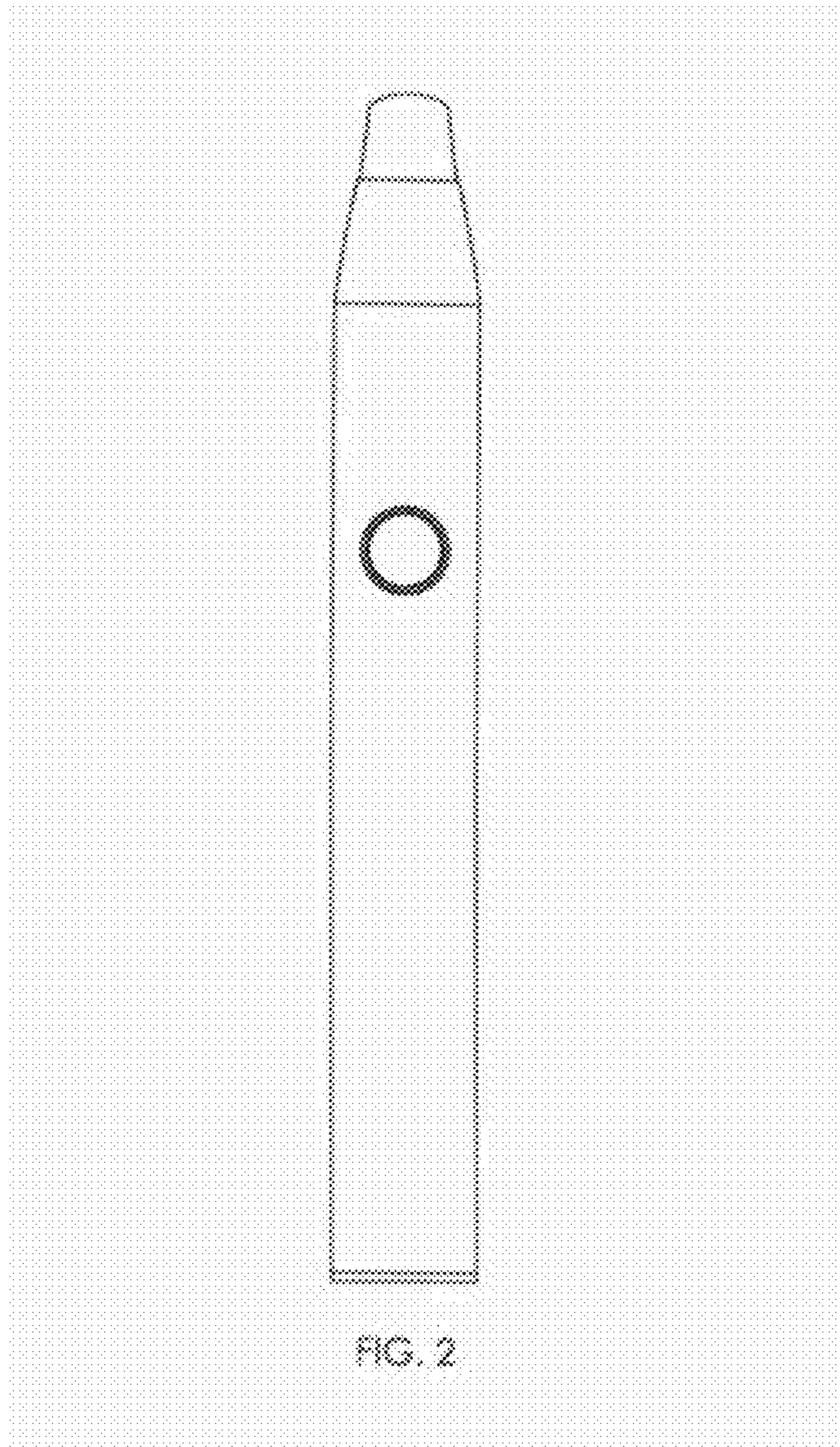
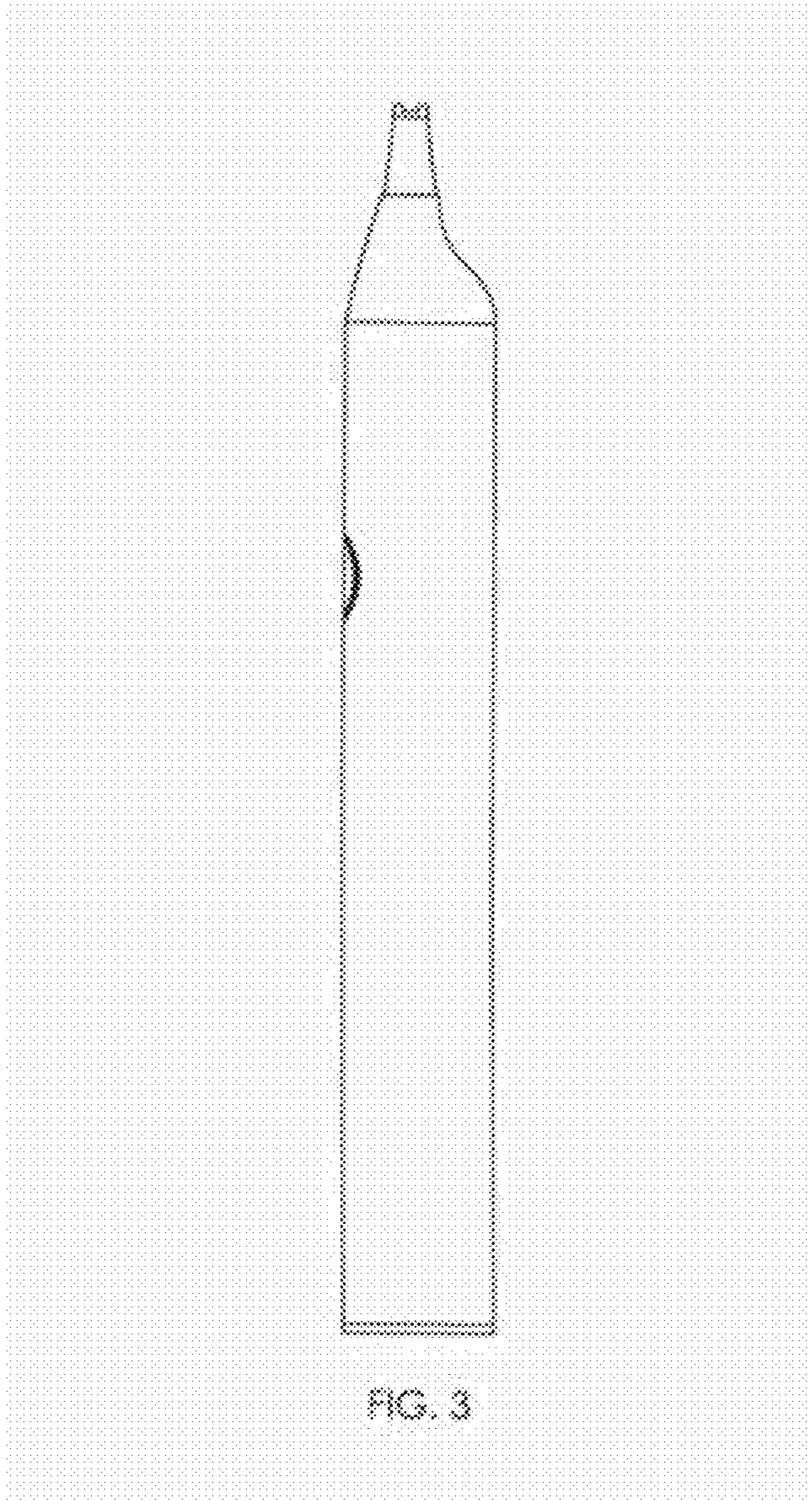

FIG. 1





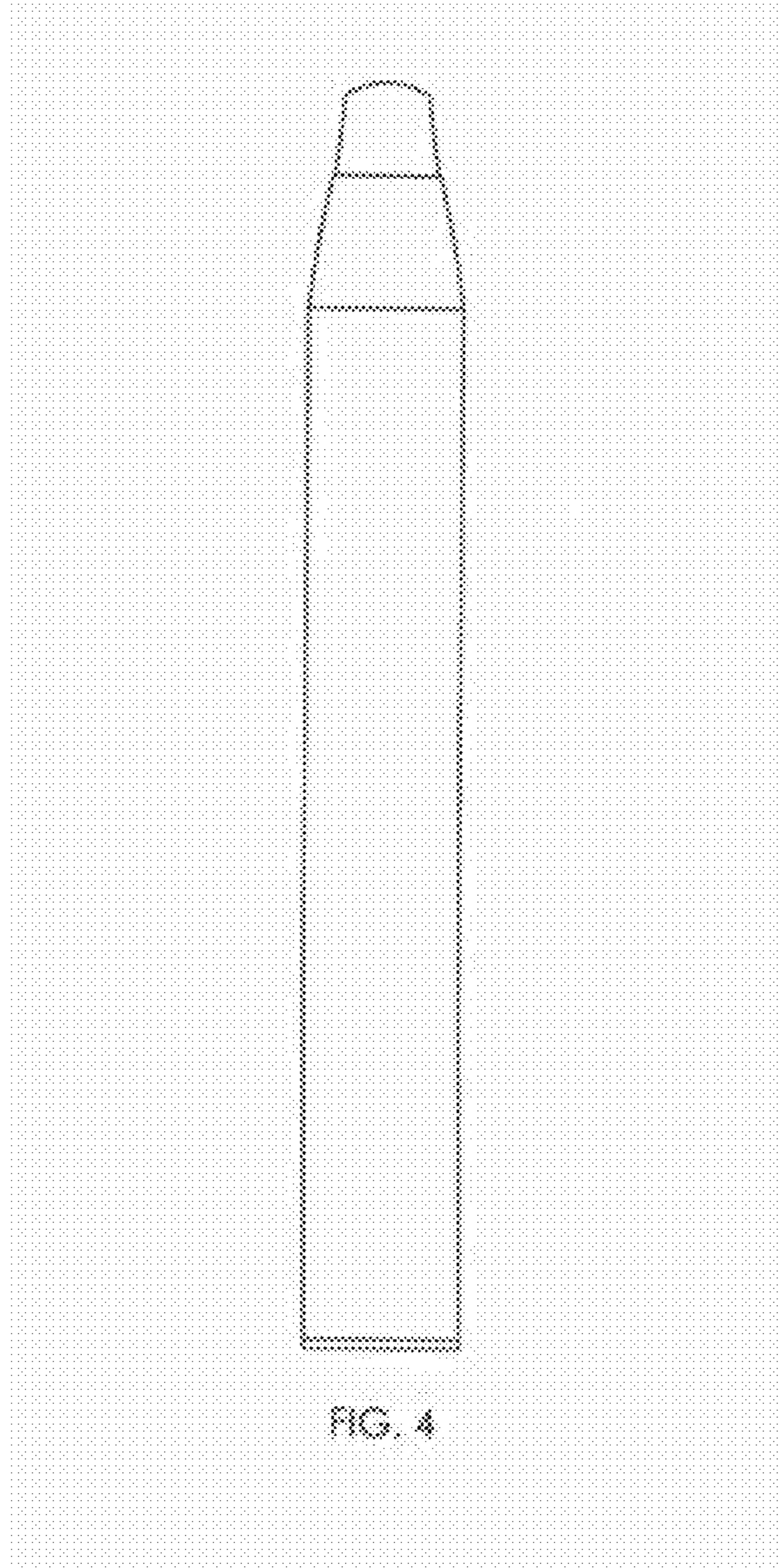

FIG. 4

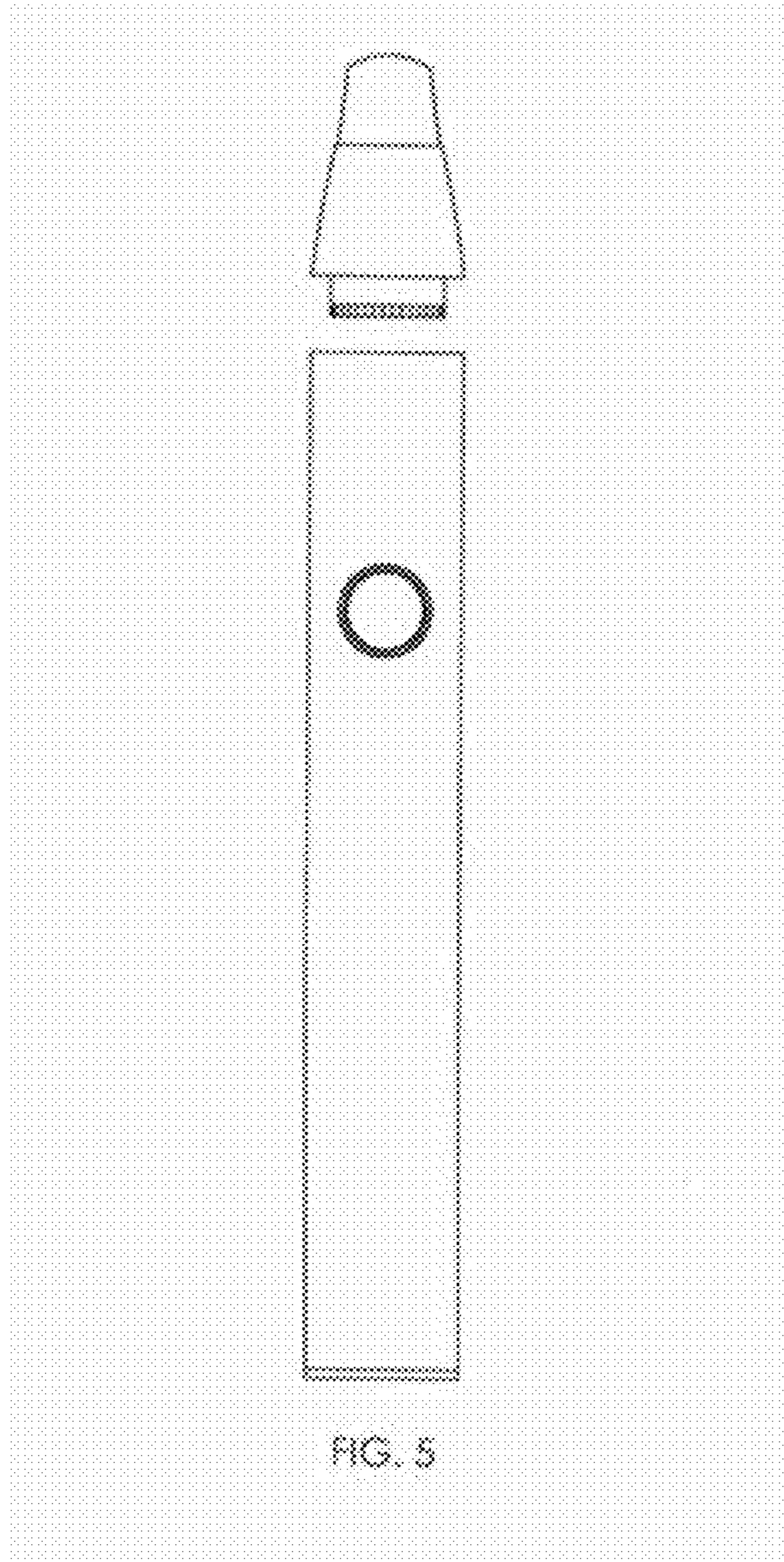
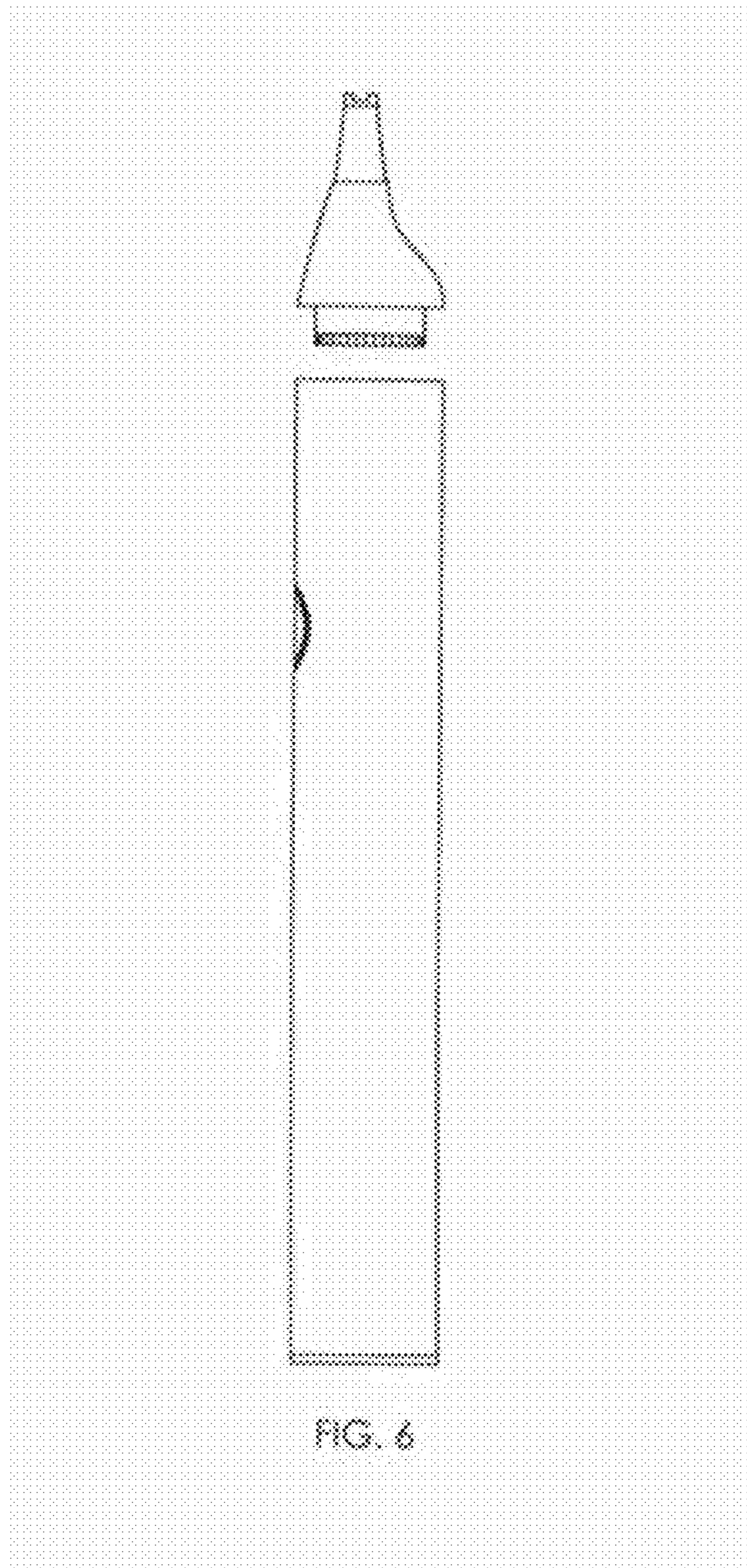
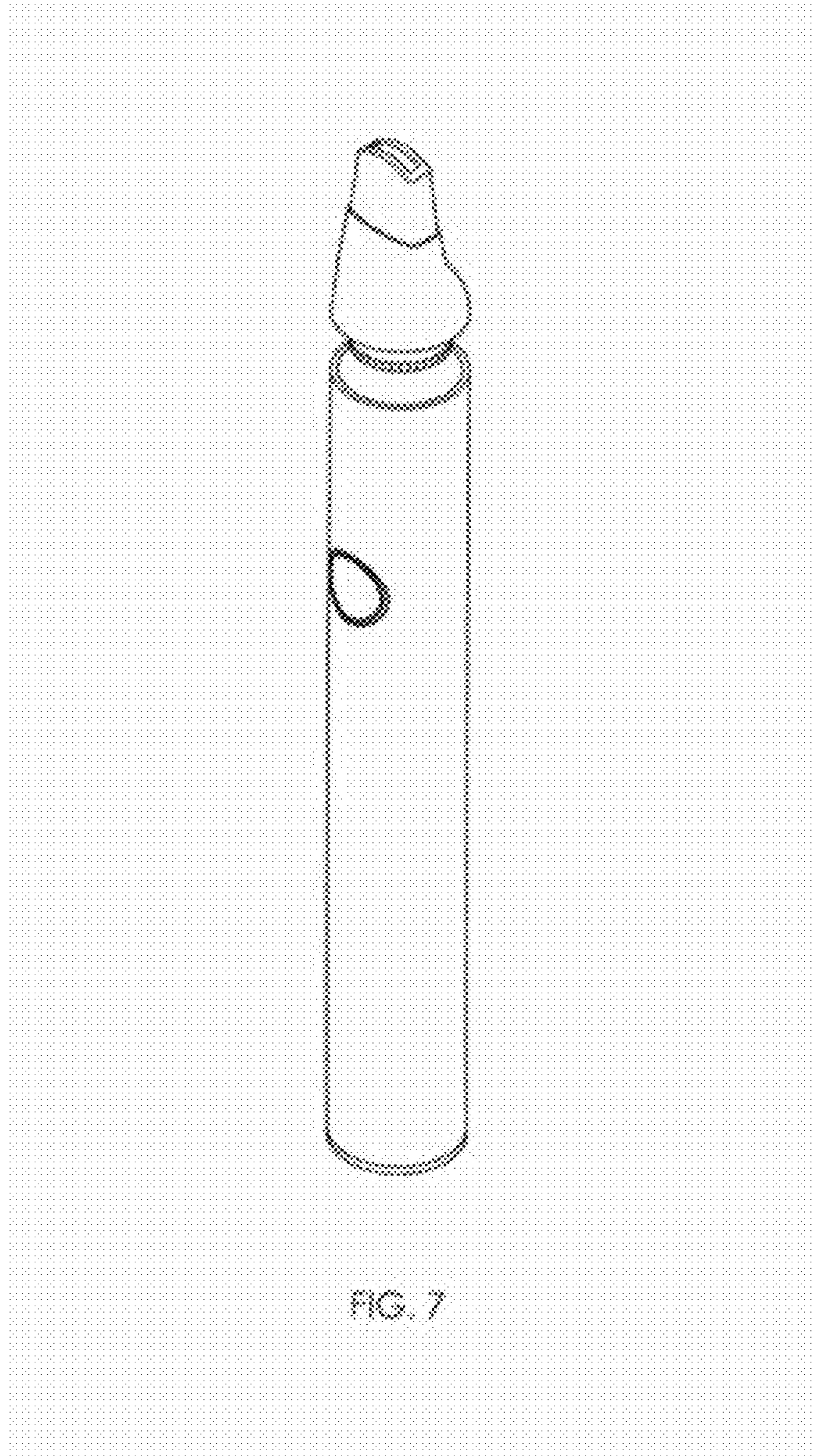

FIG. 5







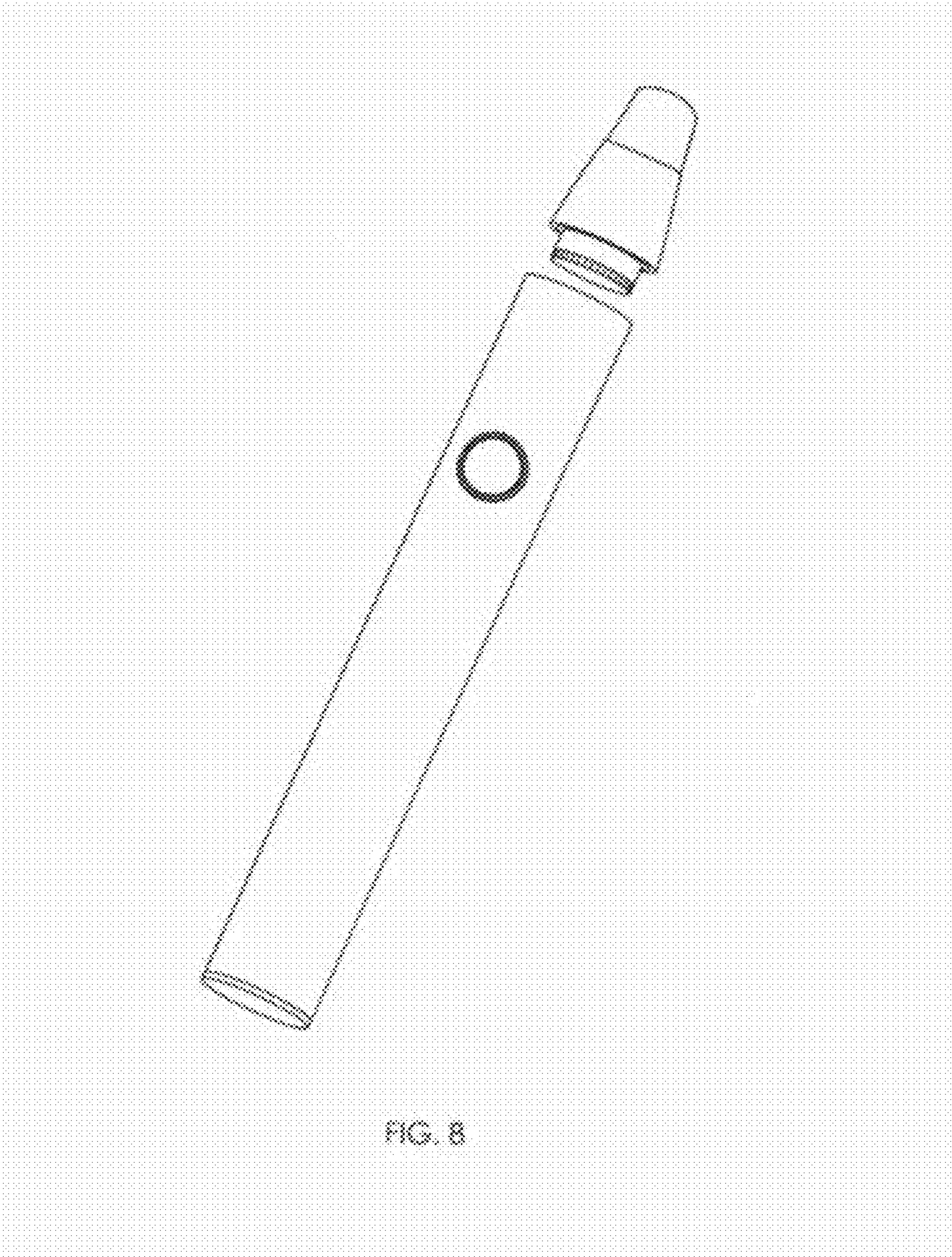

FIG. 8

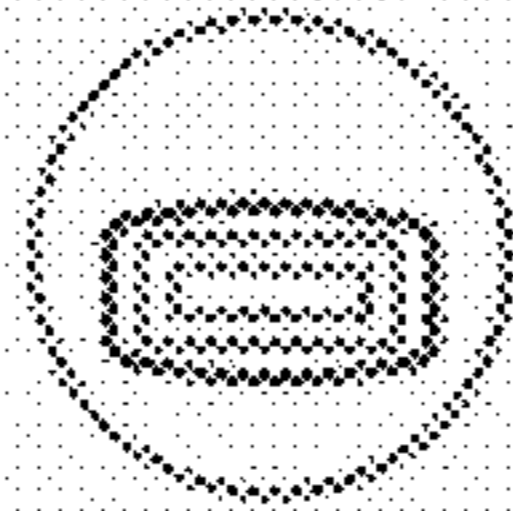

FIG. 9

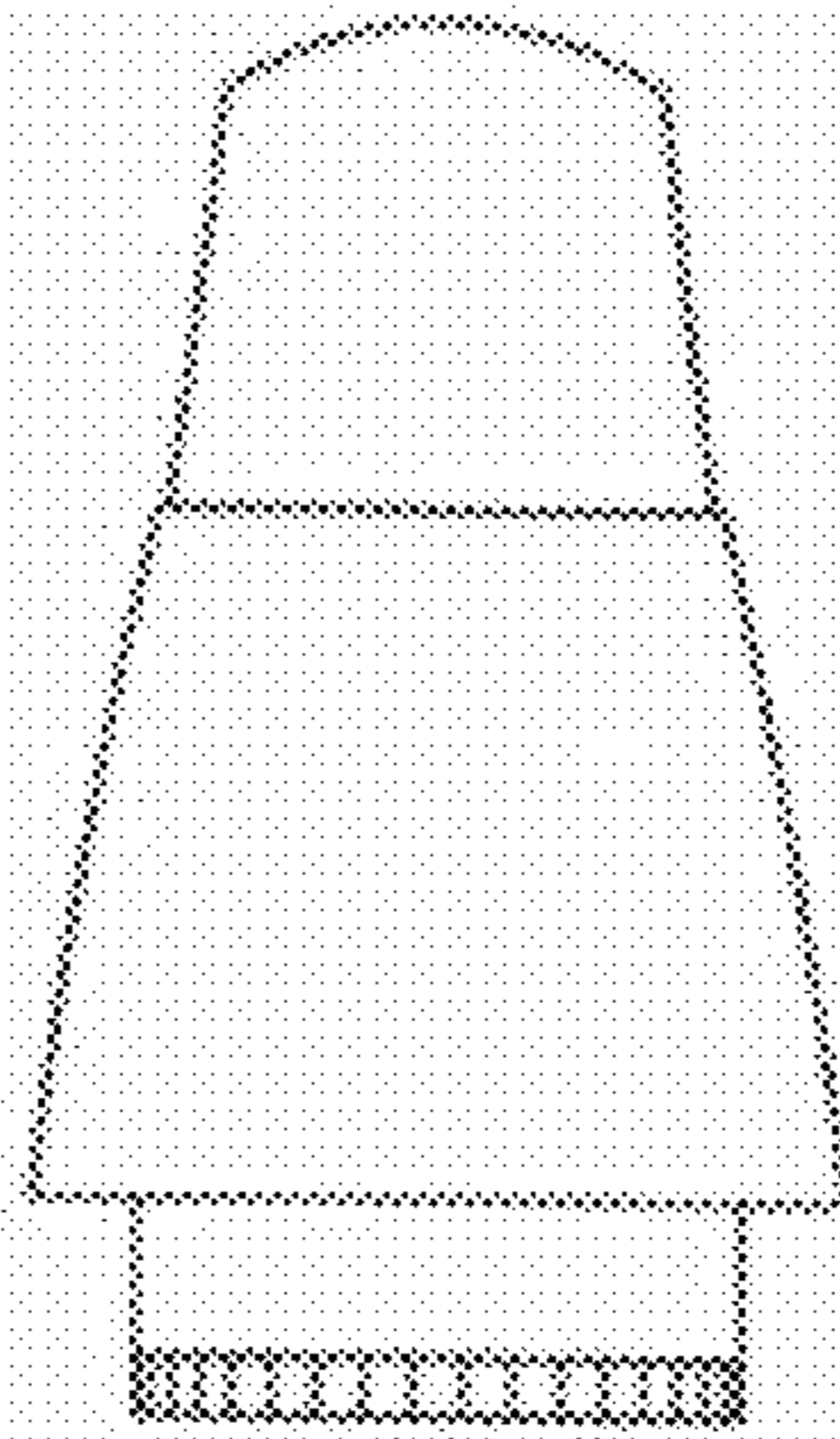

FIG. 10

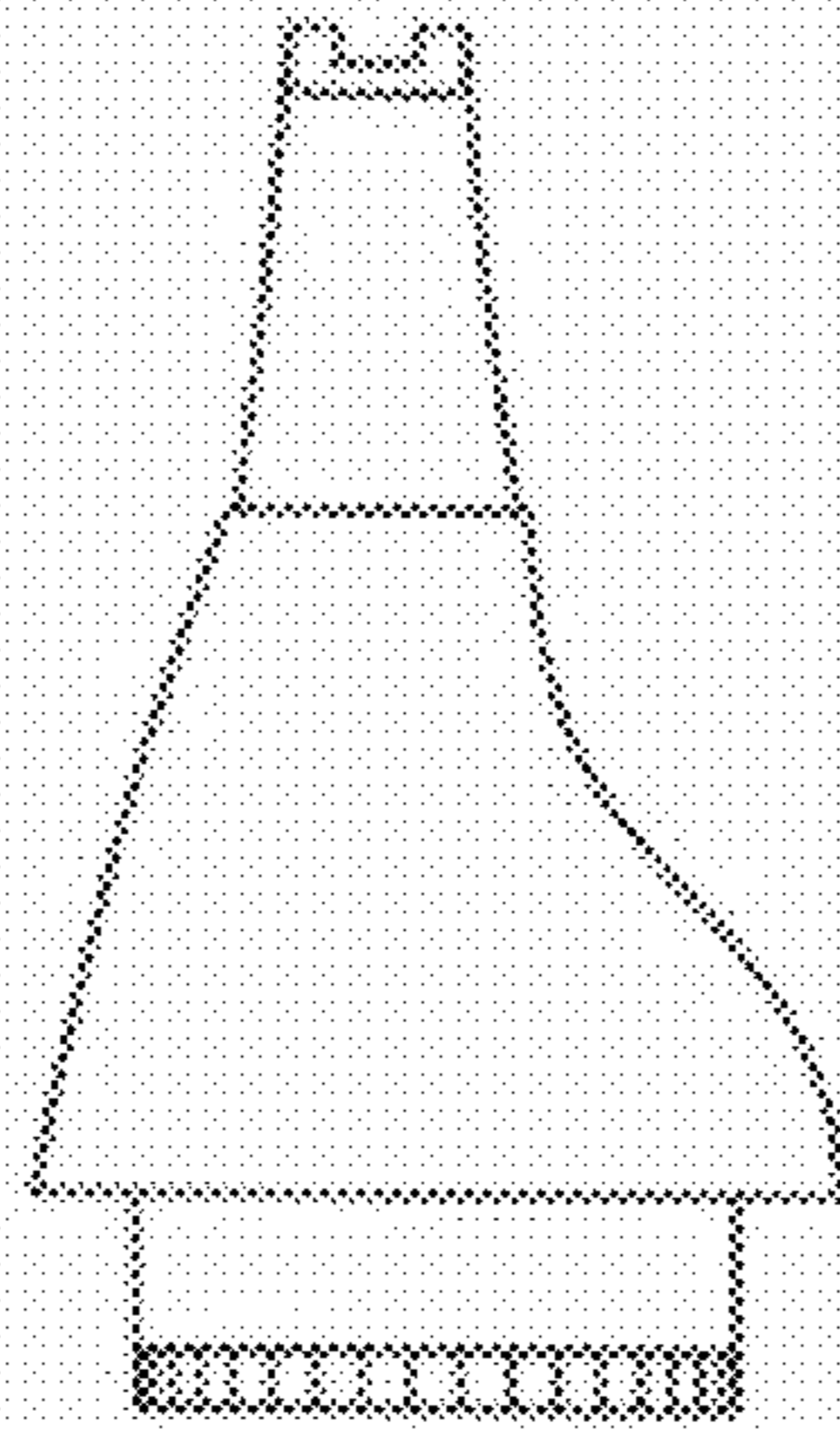

FIG. 11

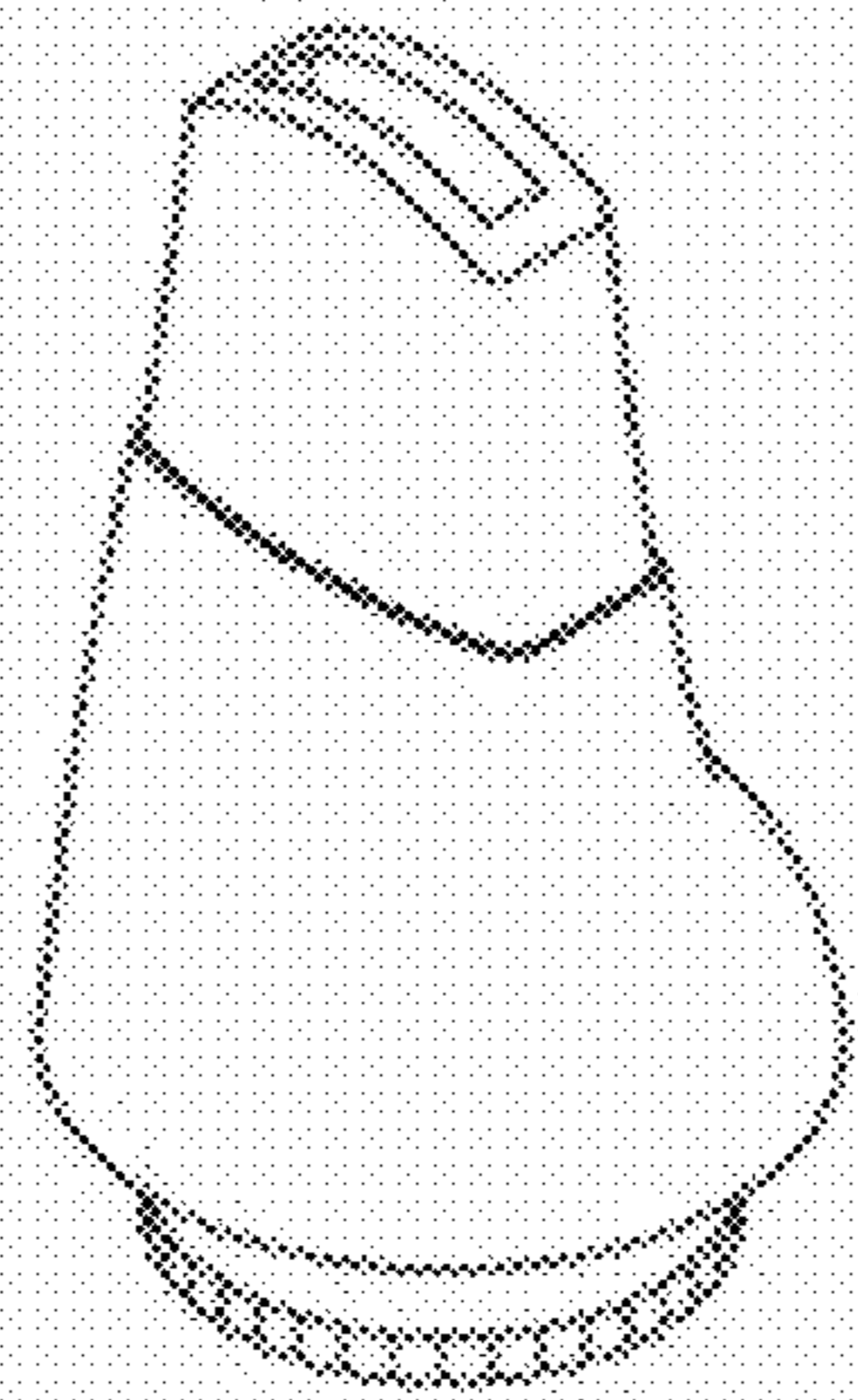

FIG. 12