



US00D760125S

(12) **United States Design Patent**
Vena et al.

(10) **Patent No.:** **US D760,125 S**
(45) **Date of Patent:** **** Jun. 28, 2016**

(54) **AIR INTAKE FOR A VEHICLE**

FOREIGN PATENT DOCUMENTS

(71) Applicant: **Daimler AG**, Stuttgart (DE)

GB 2513202 A 10/2014

(72) Inventors: **Donald Vena**, Vancouver, WA (US);
Paul Shead, Beaverton, OR (US)

OTHER PUBLICATIONS

(73) Assignee: **Daimler AG**, Stuttgart (DE)

“Transformers 4’: Meet the upgraded Optimus Prime, new Autobots,” Hero Complex, Los Angeles Times, May 30, 2013.
“Western Star Introduces the All-New 5700XE,” Western Star Trucks Press Releases, Daimler Trucks North America, Sep. 11, 2014.

(**) Term: **14 Years**

* cited by examiner

(21) Appl. No.: **29/510,235**

Primary Examiner — Melody N. Brown

(22) Filed: **Nov. 26, 2014**

(74) *Attorney, Agent, or Firm* — Crowell & Moring LLP

(30) **Foreign Application Priority Data**

May 27, 2014 (EM) 002471250-0006

(51) **LOC (10) Cl.** **12-16**

(52) **U.S. Cl.**
USPC **D12/163**

(58) **Field of Classification Search**
USPC D12/163, 196, 86, 90–92, 171, 169,
D12/216; 180/68.1, 68.6; 293/193.11
CPC B62D 25/08; B62B 9/16; B60K 11/08;
B60R 19/52
See application file for complete search history.

(57) **CLAIM**

The ornamental design for an air intake for a vehicle, as shown and described.

DESCRIPTION

FIG. 1 is a left perspective view of a first embodiment of an air intake for a vehicle according to the design;
FIG. 2 is a front view thereof;
FIG. 3 is a left side view thereof;
FIG. 4 is a top view thereof; and
FIG. 5 is a bottom view thereof.
FIG. 6 is a right perspective view of a second embodiment of the air intake for a vehicle according to the design;
FIG. 7 is a front view thereof;
FIG. 8 is a right side view thereof;
FIG. 9 is a top view thereof; and
FIG. 10 is a bottom view thereof.
The broken lines are for illustrative purposes only and form no part of the claimed design.

(56) **References Cited**

U.S. PATENT DOCUMENTS

D526,942 S * 8/2006 Delashaw D12/163
D545,729 S * 7/2007 Lee D12/163
D647,829 S * 11/2011 Medina D12/163
D647,830 S * 11/2011 Medina D12/163
D686,543 S * 7/2013 Weil D12/163
D708,990 S * 7/2014 Conway D12/163
D714,195 S * 9/2014 Conway D12/163

1 Claim, 4 Drawing Sheets

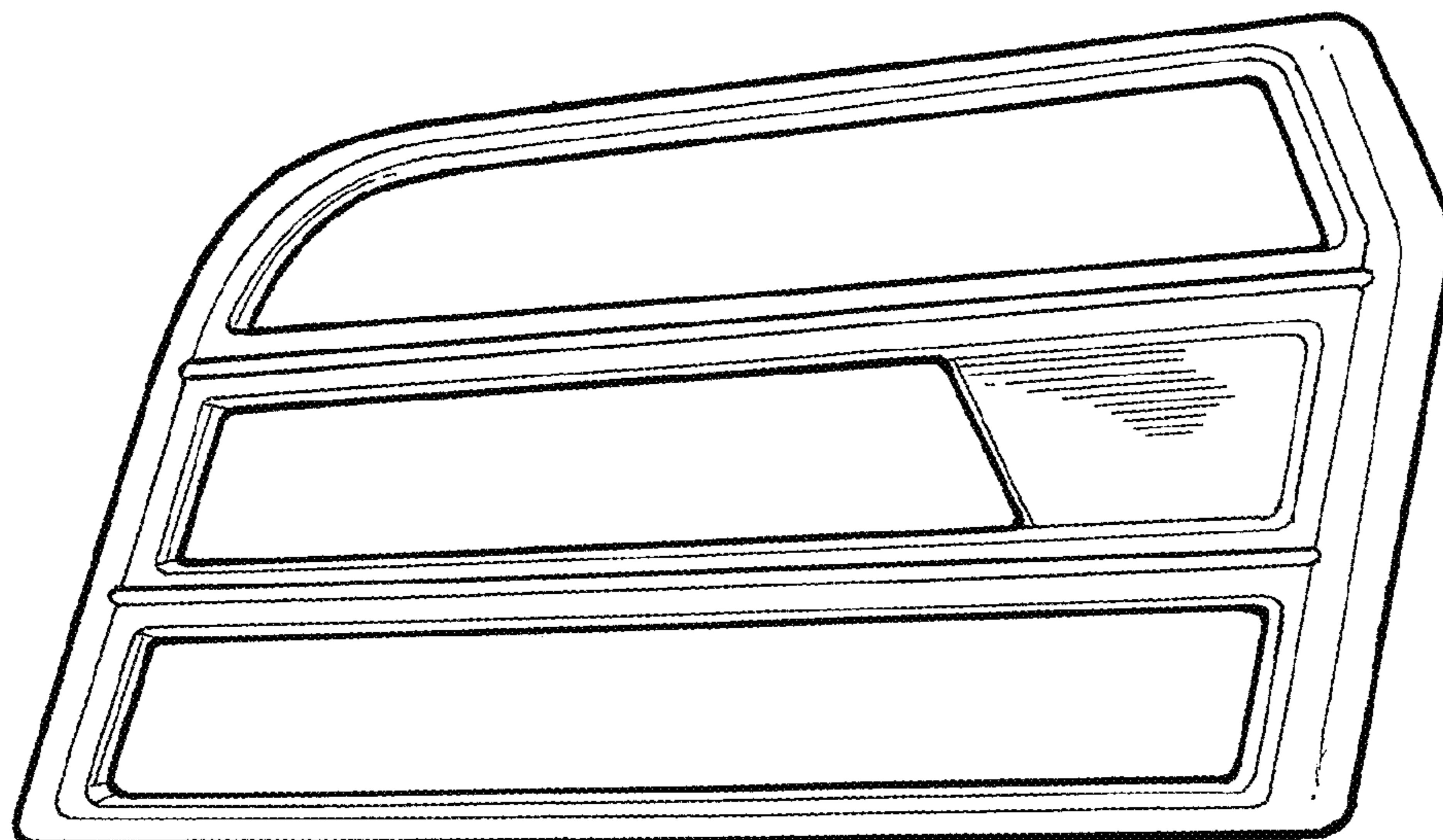

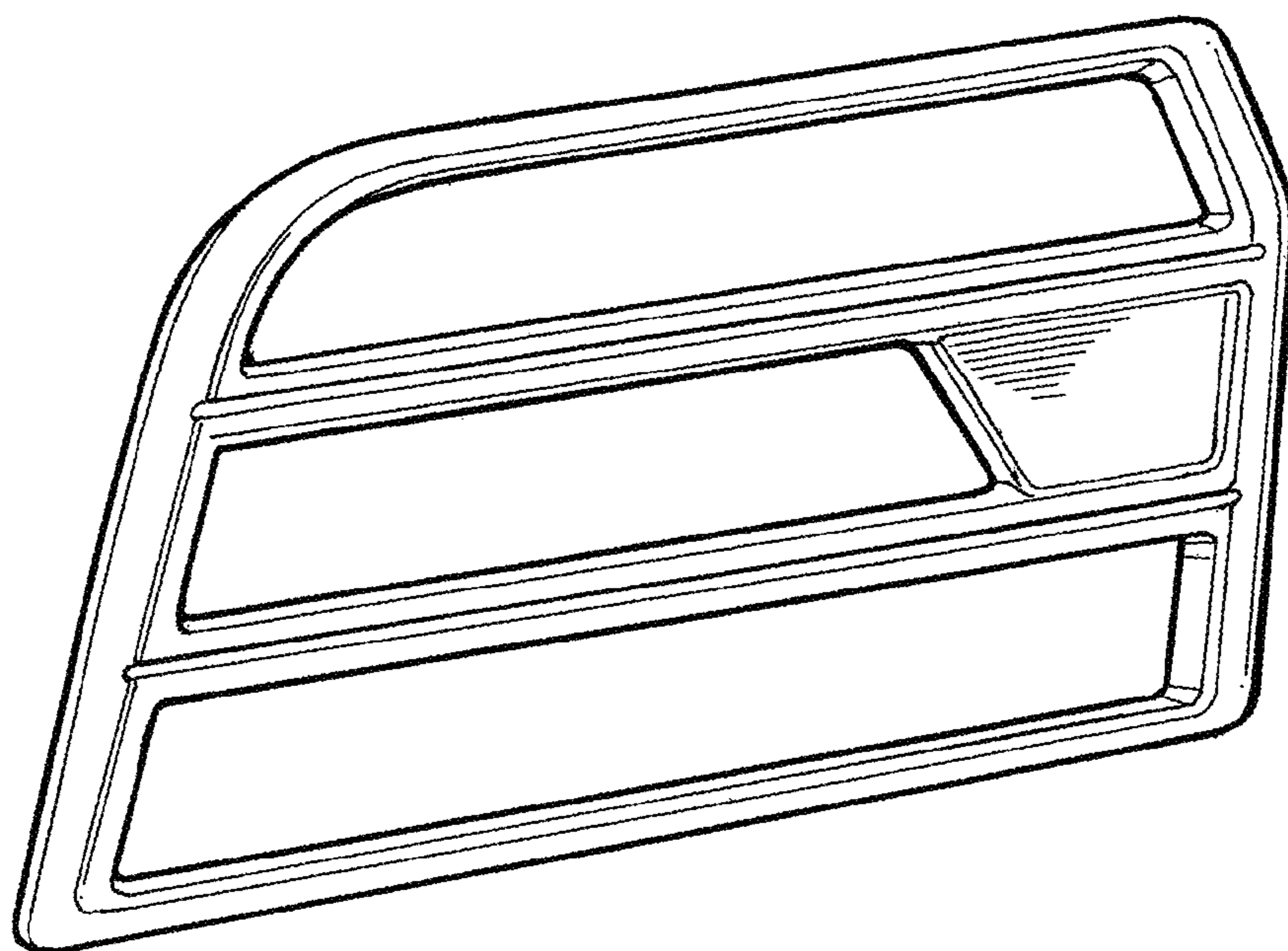

FIG. 1

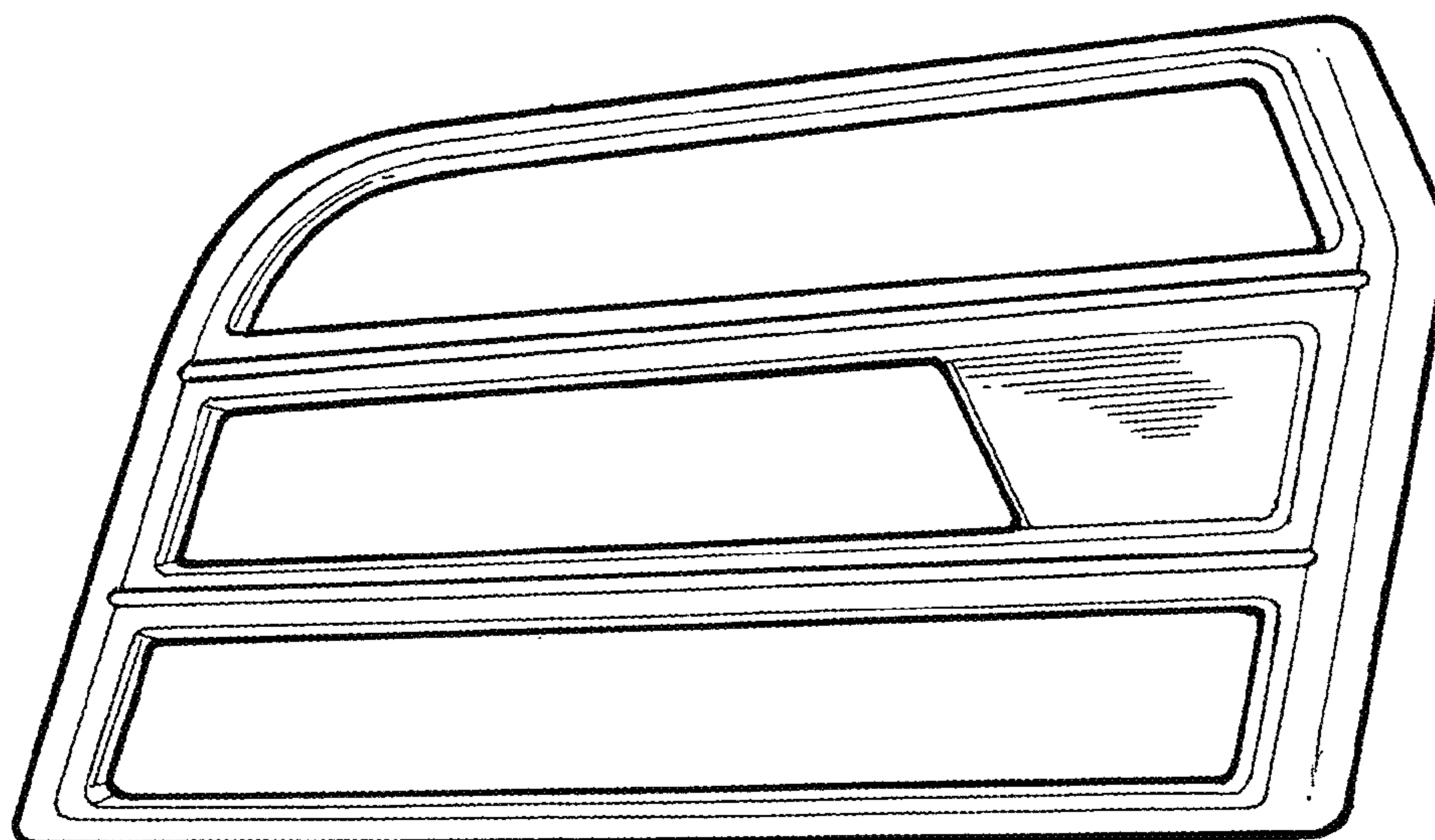

FIG. 2



FIG. 3

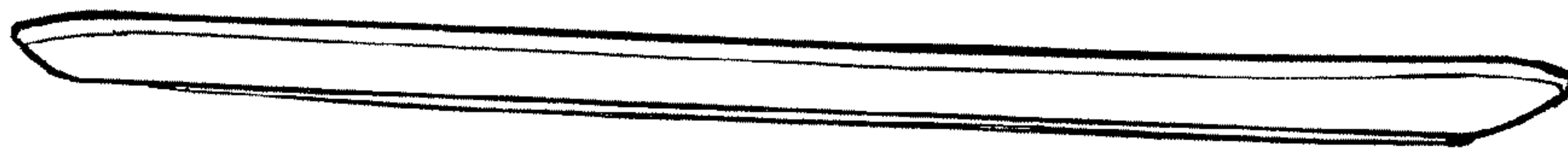

FIG. 4



FIG. 5

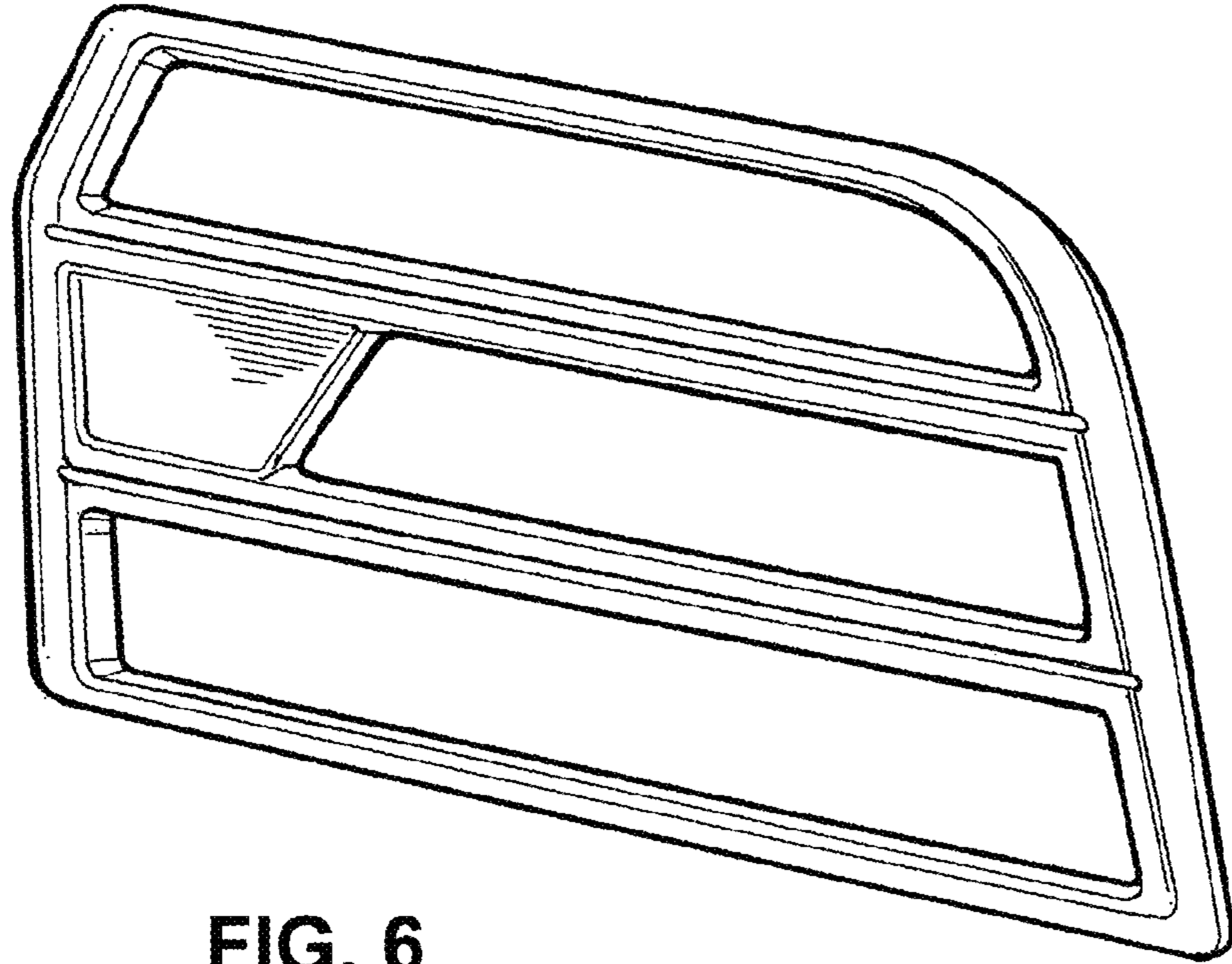

FIG. 6

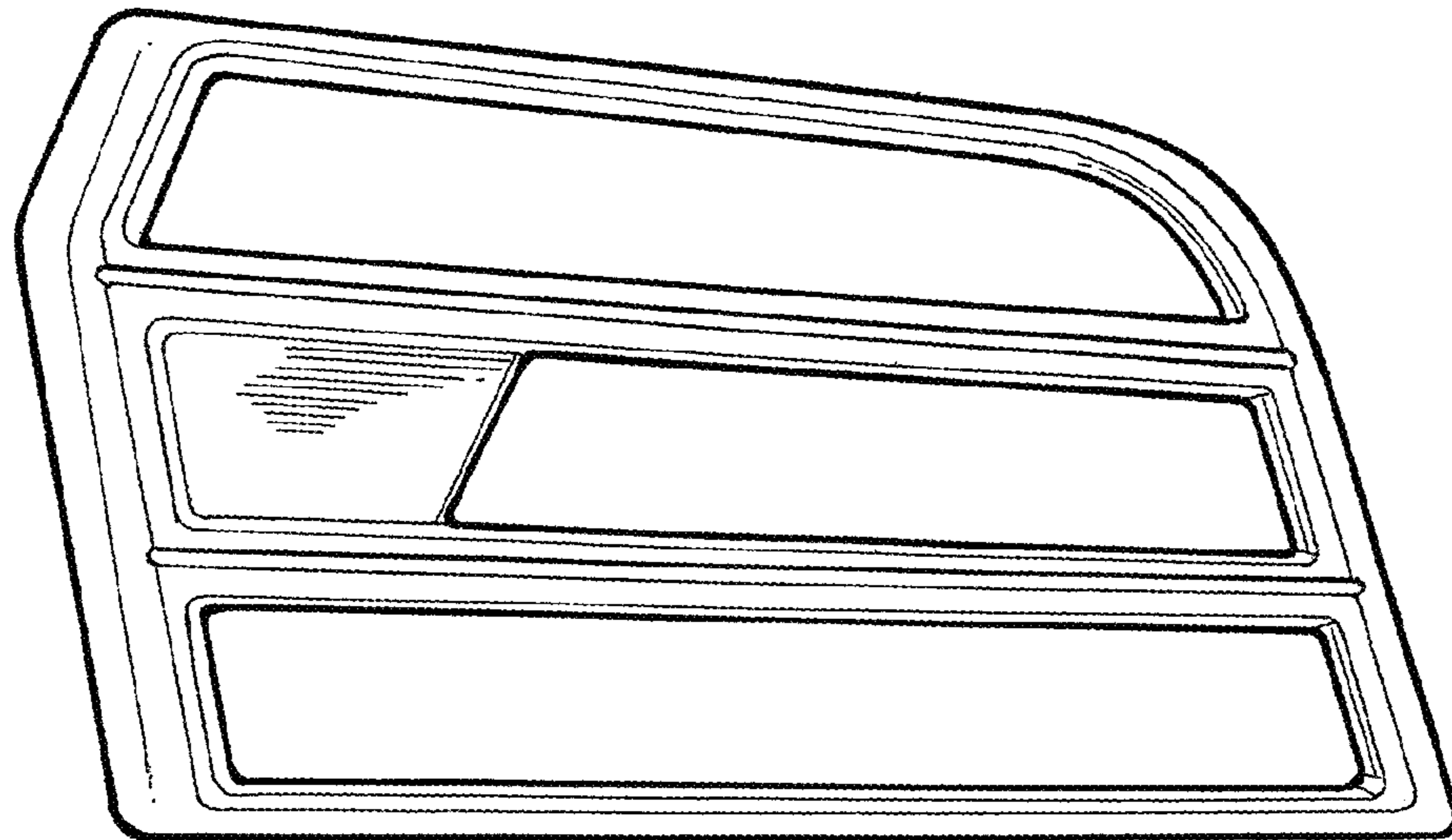

FIG. 7

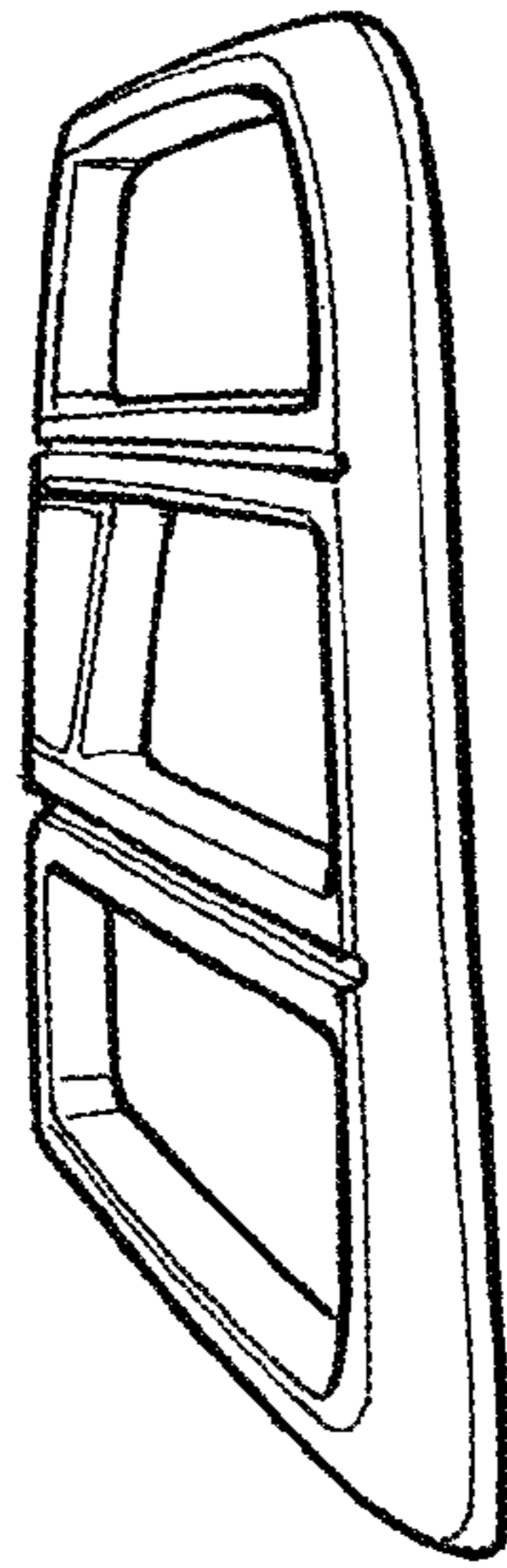

FIG. 8

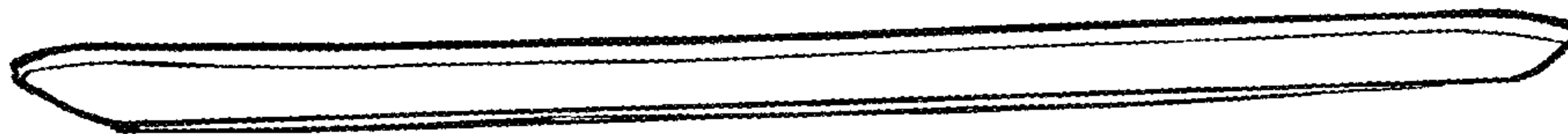

FIG. 9

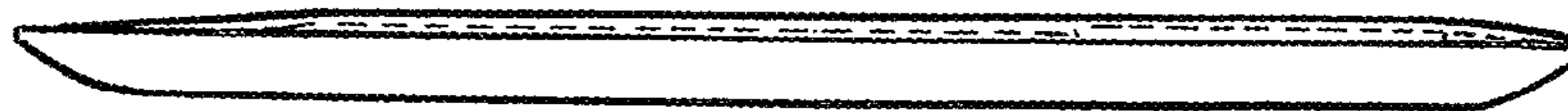

FIG. 10