



US00D759936S

(12) **United States Design Patent**  
**Kritzer**

(10) **Patent No.:** **US D759,936 S**  
(45) **Date of Patent:** **\*\* Jun. 21, 2016**

- (54) **PORTABLE AUTOMOBILE LIFT**
- (71) Applicant: **BendPak, Inc.**, Santa Paula, CA (US)
- (72) Inventor: **Jeffrey S. Kritzer**, Moorpark, CA (US)
- (73) Assignee: **BENDPAK, INC.**, Santa Paula, CA (US)
- (\*\*) Term: **15 Years**
- (21) Appl. No.: **29/547,399**
- (22) Filed: **Dec. 3, 2015**

5,636,711	A *	6/1997	Nussbaum	.....	B66F 7/0666	182/141
6,257,372	B1 *	7/2001	Schirmer	.....	B66B 9/0853	187/269
6,318,929	B1 *	11/2001	Basta	.....	B63C 3/00	114/44
6,619,620	B1 *	9/2003	Carter	.....	B66F 7/0625	254/10 C
7,299,758	B1 *	11/2007	Bogart	.....	B63C 3/06	114/44
D632,450	S *	2/2011	Agoncillo	.....	D34/28	
8,733,508	B2 *	5/2014	Bacon	.....	B66F 7/065	187/240
D716,514	S *	10/2014	Kritzer	.....	D34/28	
D748,361	S *	1/2016	Kritzer	.....	D34/28	
2009/0272953	A1 *	11/2009	Wolf	.....	B66F 7/0625	254/7 C
2015/0076431	A1 *	3/2015	Kritzer	.....	B66F 5/04	254/89 H

**Related U.S. Application Data**

- (63) Continuation-in-part of application No. 29/498,920, filed on Aug. 8, 2014, now Pat. No. Des. 748,361, which is a continuation-in-part of application No. 29/467,149, filed on Sep. 16, 2013, now Pat. No. Des. 716,514.
- (51) **LOC (10) Cl.** ..... **12-05**
- (52) **U.S. Cl.**  
USPC ..... **D34/28**
- (58) **Field of Classification Search**  
USPC ..... D34/28-37; 254/1, 10 R, 122, 93 R, 8 B, 254/10 C, 8 R, 9 C, 10 B, 9 B, 9 R, 93 H, 133 R, 254/124, 88, 90, 1 R, 45, 89 H, 89 R, 8.43; D12/101, 406, 408, 410, 402, 2 C, 154; 414/539, 540, 541, 678, 921  
CPC ..... B66F 7/0641; B66F 7/08; B66F 3/46; B66F 7/16; B66F 7/20; B66F 11/04; B66F 3/00; B66F 3/02; B66F 11/00  
See application file for complete search history.

\* cited by examiner

*Primary Examiner* — Cynthia Ramirez

*Assistant Examiner* — Gino Colan

(74) *Attorney, Agent, or Firm* — Erickson Kernell Derusseau & Kleypas, LLC

(57) **CLAIM**

The ornamental design for a portable automobile lift, as shown and described.

**DESCRIPTION**

FIG. 1 is a perspective view of a portable automobile lift; FIG. 2 is a left side elevational view thereof; FIG. 3 is a right side elevational view thereof; FIG. 4 is a front elevational view thereof; FIG. 5 is a rear elevational view thereof; FIG. 6 is a top plan view thereof; and, FIG. 7 is a bottom plan view thereof.

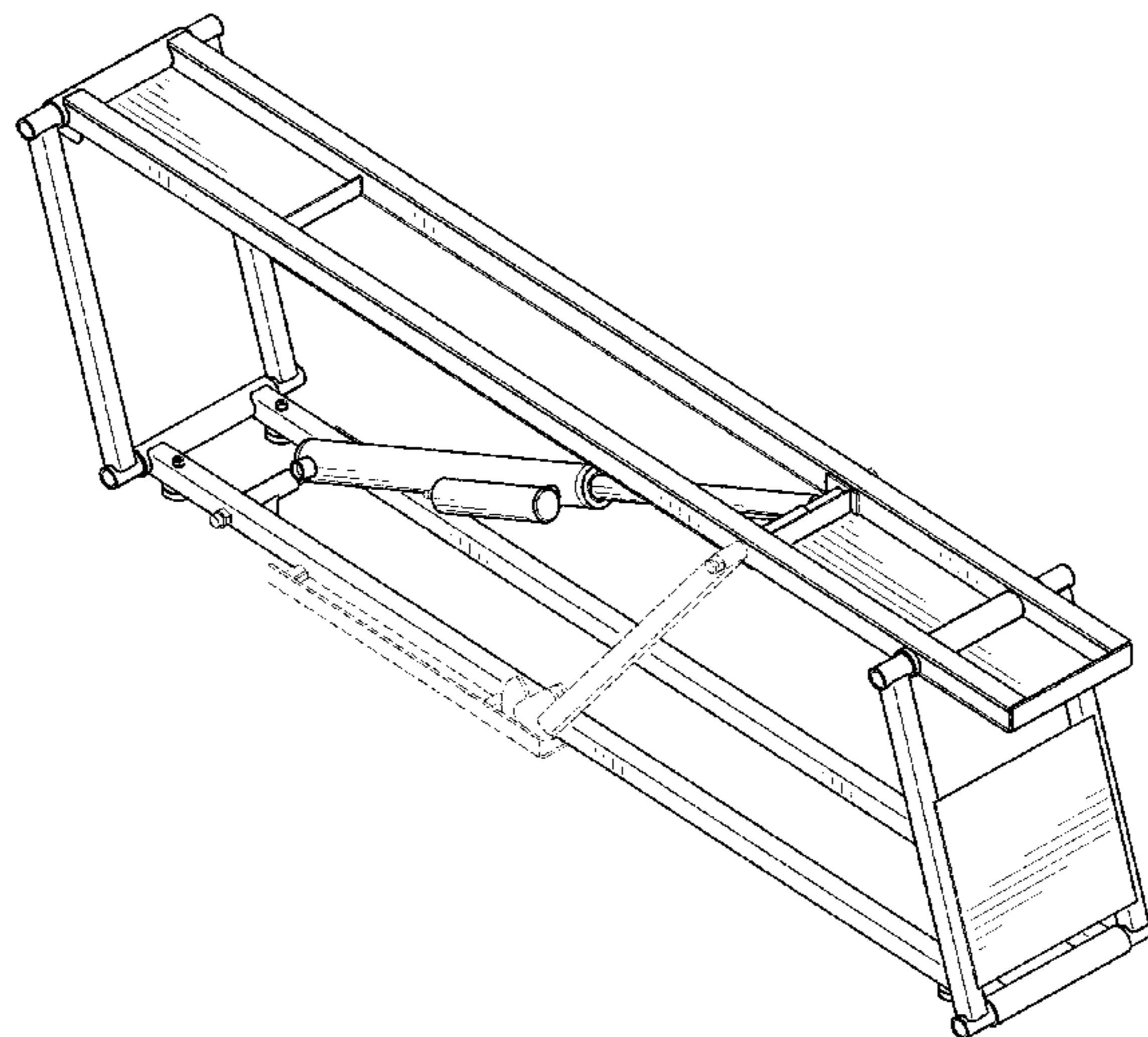
The broken lines in the figures are included for the purpose of illustrating portions of the portable automobile lift that form no part of the claimed design.

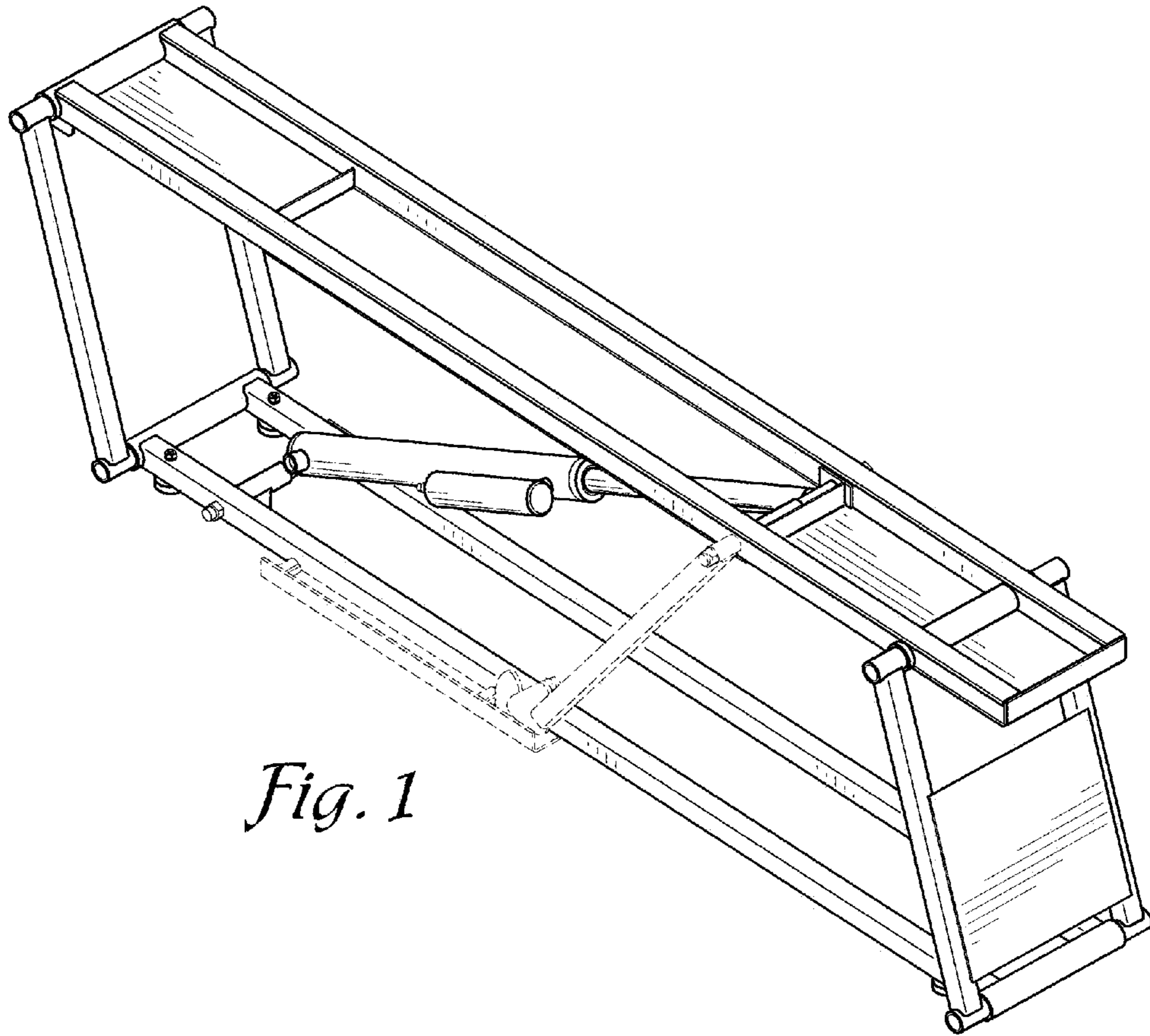
**1 Claim, 3 Drawing Sheets**

(56) **References Cited**

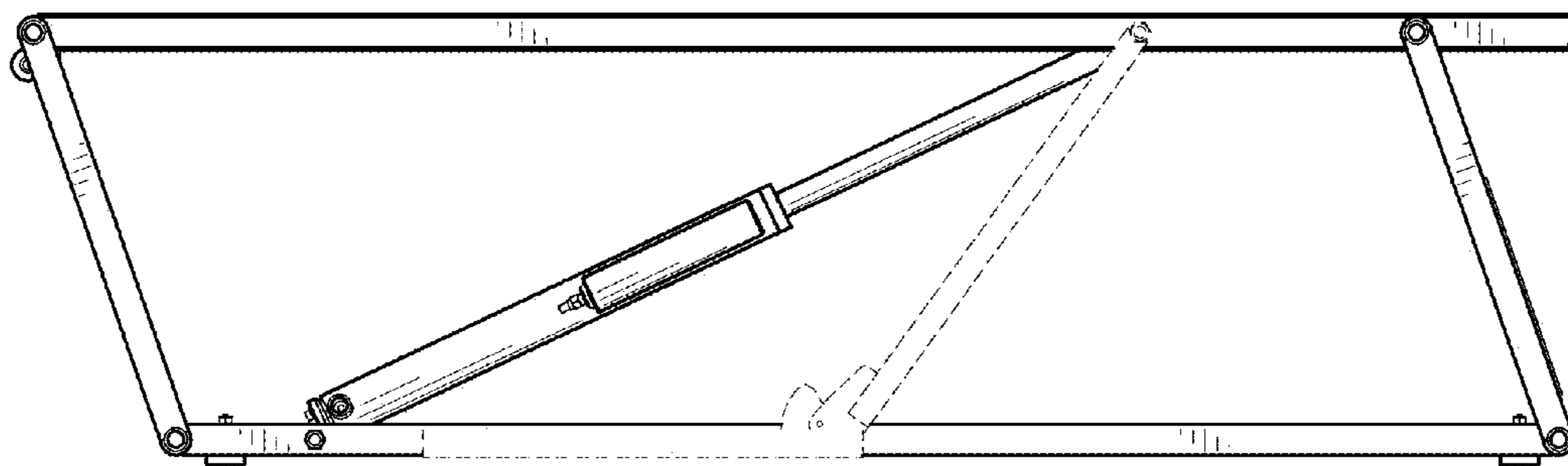
**U.S. PATENT DOCUMENTS**

- 5,007,121 A \* 4/1991 McEathron ..... A61G 7/1003 254/10 C
- D375,602 S \* 11/1996 Henthorn ..... D34/28

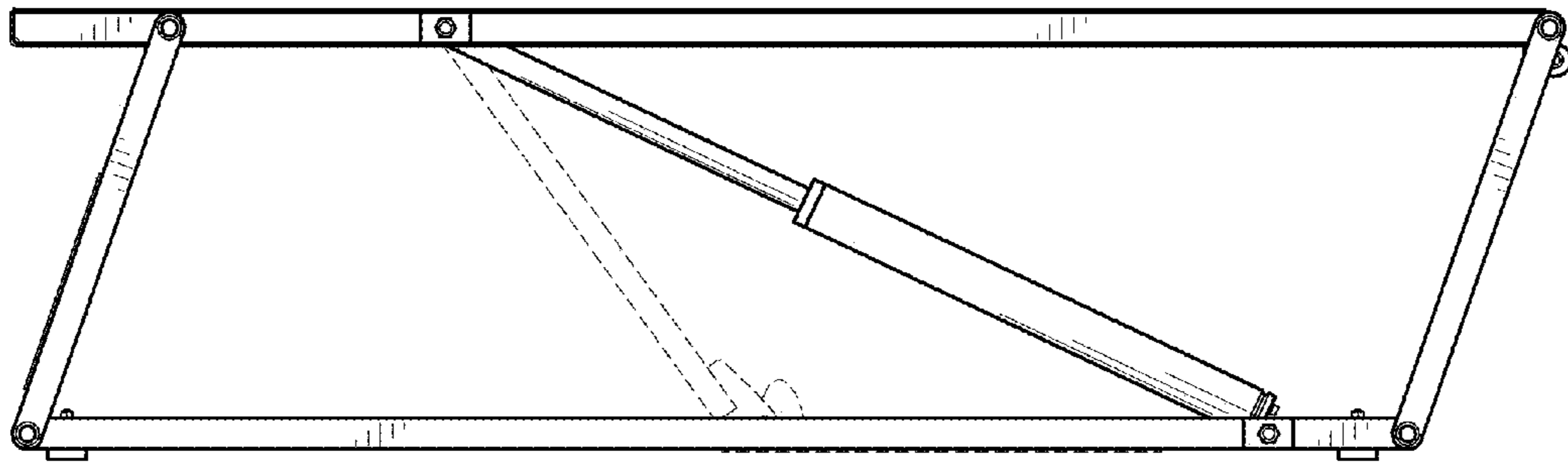




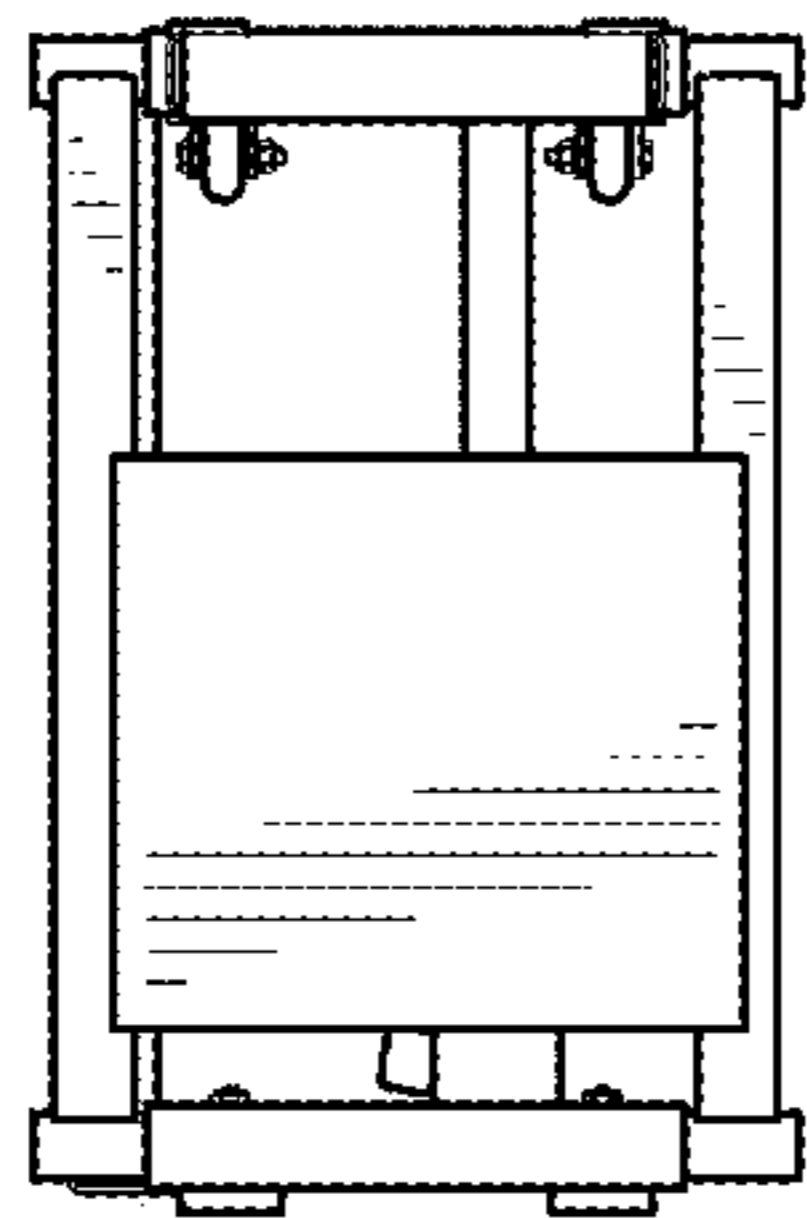
*Fig. 1*



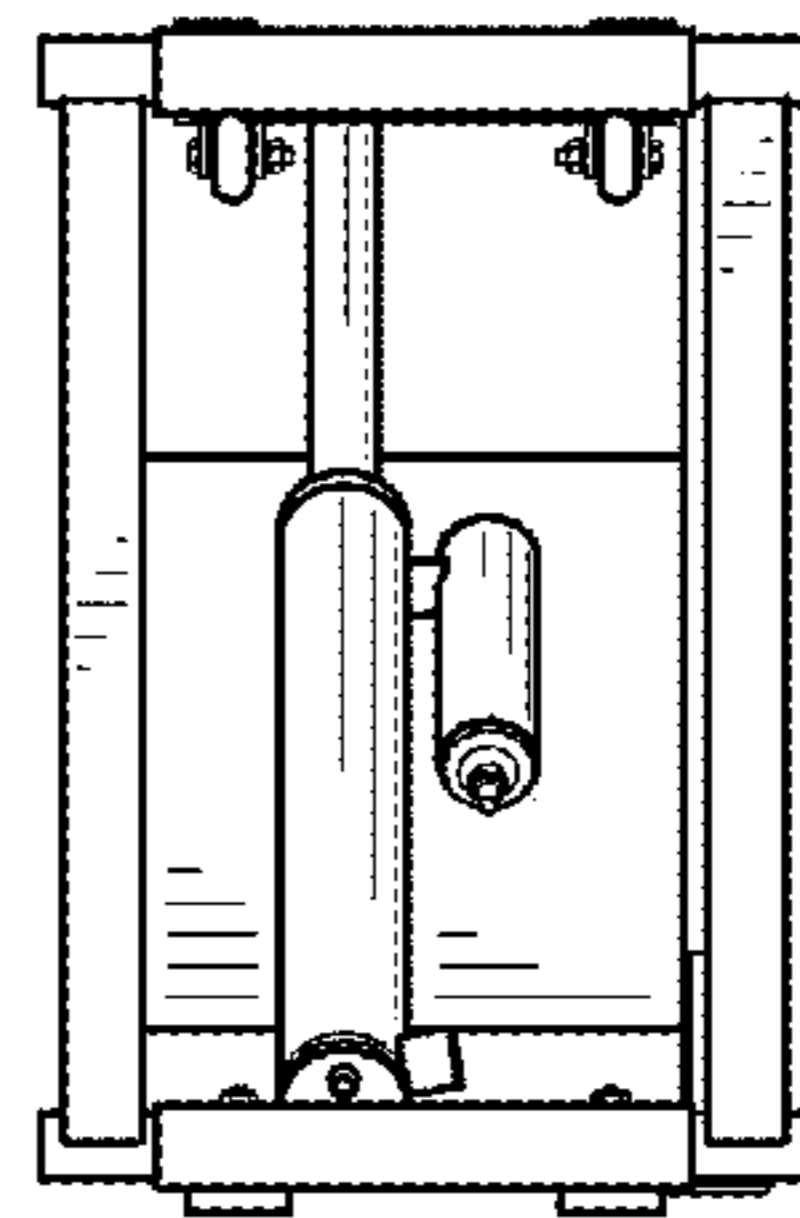
*Fig. 2*



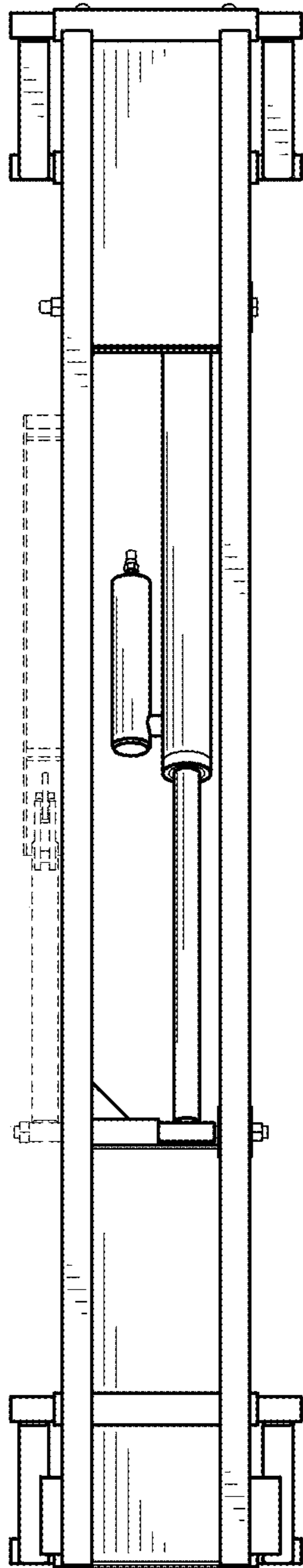
*Fig. 3*



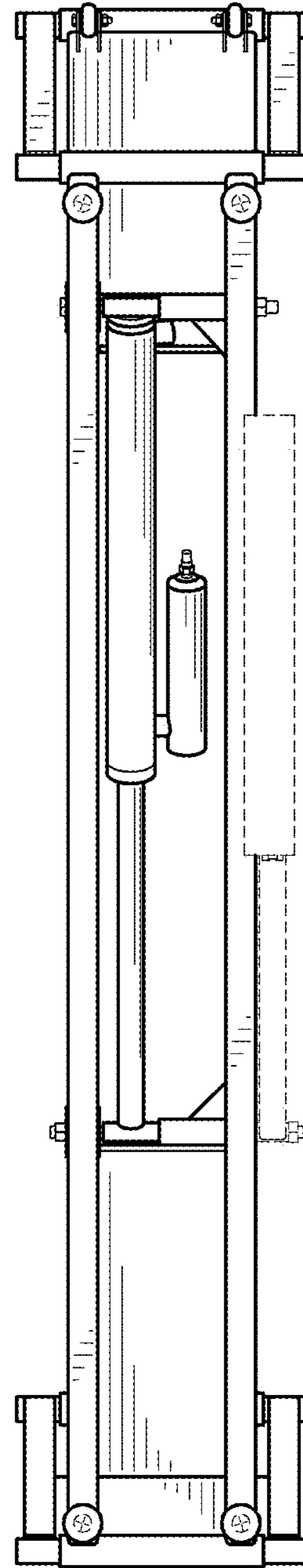
*Fig. 4*



*Fig. 5*



*Fig. 6*



*Fig. 7*