



US00D759803S

(12) **United States Design Patent**
Wagner et al.

(10) **Patent No.:** **US D759,803 S**
(45) **Date of Patent:** **** Jun. 21, 2016**

(54) **ADJUSTABLE HEADPIECE WITH ANATOMICAL MARKERS**

- (71) Applicant: **Highland Instruments, Inc.**,
Somerville, MA (US)
- (72) Inventors: **Timothy Andrew Wagner**, Somerville,
MA (US); **William Edelman**, Sharon,
MA (US); **Laura Dipietro**, Cambridge,
MA (US); **Paul James Mulhauser**, New
York, NY (US); **Kyungmin Andy Lee**,
New York, NY (US)
- (73) Assignee: **Highland Instruments, Inc.**,
Somerville, MA (US)

(**) Term: **14 Years**

(21) Appl. No.: **29/507,490**

(22) Filed: **Oct. 28, 2014**

(51) **LOC (10) Cl.** **24-01**

(52) **U.S. Cl.**
USPC **D24/107**

(58) **Field of Classification Search**
USPC D24/107, 108, 140, 144, 170, 187, 191,
D24/200, 231
CPC A61N 1/375; A61N 2005/0647; A61B
5/6803; A61M 16/0683
See application file for complete search history.

(56) **References Cited**

U.S. PATENT DOCUMENTS

2,830,578 A 4/1958 Degroff et al.
2,838,672 A 6/1958 Leah et al.

(Continued)

FOREIGN PATENT DOCUMENTS

WO 2006/027757 A2 3/2006
WO 2007/149811 A2 12/2007

(Continued)

OTHER PUBLICATIONS

Advanced Development for Defense Science and Technology, Apr. 5,
2010, 93 pages.

(Continued)

Primary Examiner — Barbara Fox
Assistant Examiner — Lilyana Bekic

(74) *Attorney, Agent, or Firm* — Brown Rudnick LLP; Mark
S. Leonardo; Adam M. Schoen

(57) **CLAIM**

The ornamental design for an adjustable headpiece with ana-
tomical markers, as shown and described.

DESCRIPTION

This invention was made with government support under
5R44NS080632 awarded by the National Institute of Neuro-
logical Disorders and Stroke (NINDS) of the National Insti-
tute of Health (NIH). The government has certain rights in the
invention.

FIG. 1 illustrates a front side perspective view of an adjust-
able headpiece with anatomical markers in accordance with
the present invention;

FIG. 2 illustrates a back side perspective view of the adjust-
able headpiece with anatomical markers of FIG. 1;

FIG. 3 illustrates a front side view of the adjustable headpiece
with anatomical markers of FIG. 1;

FIG. 4 illustrates a back side view of the adjustable headpiece
with anatomical markers of FIG. 1;

FIG. 5 illustrates a left side view of the adjustable headpiece
with anatomical markers of FIG. 1;

FIG. 6 illustrates a right side view of the adjustable headpiece
with anatomical markers of FIG. 1;

FIG. 7 illustrates a top side view of the adjustable headpiece
with anatomical markers of FIG. 1; and,

FIG. 8 illustrates a bottom side view of the adjustable head-
piece with anatomical markers of FIG. 1.

The broken lines in the drawings illustrate portions of the
adjustable headpiece with anatomical markers that form no
part of the claimed design.

1 Claim, 8 Drawing Sheets

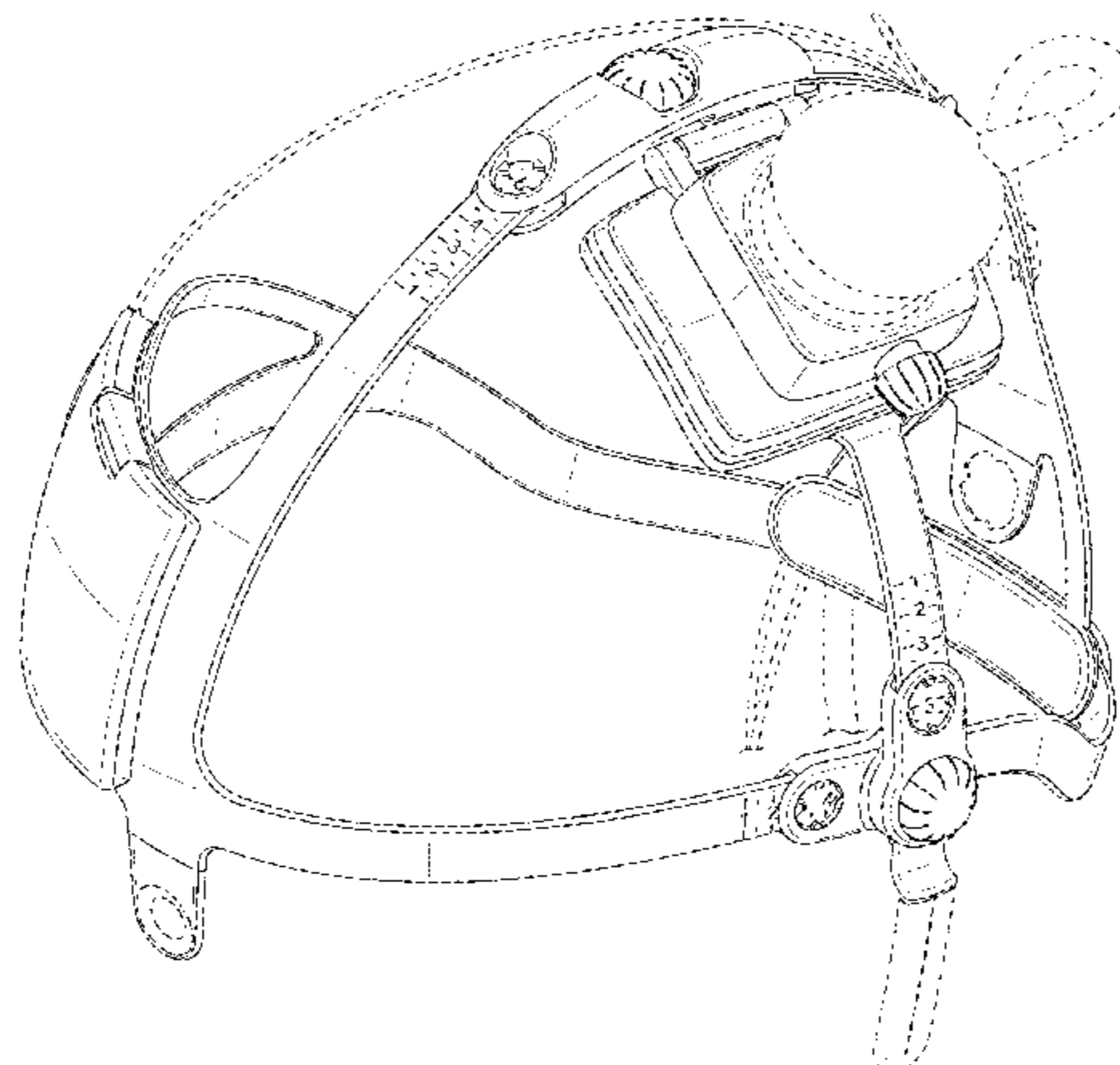

(56)

References Cited

U.S. PATENT DOCUMENTS

| | | | | | | | | | |
|-----------|-----|---------|-----------------------|-------|------------------------|--------------|------|---------|---------------------------------------|
| 3,285,242 | A * | 11/1966 | Wallace | | F21L 14/00 362/105 | 6,520,903 | B1 | 2/2003 | Yamashiro |
| D209,116 | S * | 10/1967 | Treutelaar | | D24/188 | 6,520,911 | B1 | 2/2003 | Wen |
| 3,464,416 | A * | 9/1969 | Williams | | A61N 1/36014 600/26 | 6,535,767 | B1 | 3/2003 | Kronberg |
| 3,735,756 | A | 5/1973 | Richards et al. | | | 6,536,440 | B1 | 3/2003 | Dawson |
| 3,822,708 | A | 7/1974 | Zilber | | | 6,546,290 | B1 | 4/2003 | Shloznikov |
| 4,305,402 | A | 12/1981 | Katims | | | 6,567,702 | B1 | 5/2003 | Nekhendzy et al. |
| 4,503,863 | A | 3/1985 | Katims | | | 6,584,357 | B1 | 6/2003 | Dawson |
| 4,535,785 | A | 8/1985 | van den Honert et al. | | | 6,591,138 | B1 | 7/2003 | Fischell et al. |
| 4,611,596 | A | 9/1986 | Wasserman | | | 6,615,080 | B1 | 9/2003 | Unsworth et al. |
| 4,641,633 | A | 2/1987 | Delgado | | | 6,645,144 | B1 | 11/2003 | Wen et al. |
| 4,672,951 | A | 6/1987 | Welch | | | 6,654,642 | B2 | 11/2003 | North et al. |
| 4,709,700 | A | 12/1987 | Hyrman | | | 6,681,131 | B2 | 1/2004 | Kandori et al. |
| 4,723,536 | A | 2/1988 | Rauscher et al. | | | 6,685,729 | B2 | 2/2004 | Gonzalez |
| 4,759,377 | A | 7/1988 | Dykstra | | | 6,692,490 | B1 | 2/2004 | Edwards |
| 4,805,636 | A | 2/1989 | Barry et al. | | | 6,721,603 | B2 | 4/2004 | Zabara et al. |
| 4,889,526 | A | 12/1989 | Rauscher et al. | | | 6,729,337 | B2 | 5/2004 | Dawson |
| 4,923,437 | A | 5/1990 | Gordon | | | 6,764,498 | B2 | 7/2004 | Mische |
| 4,989,605 | A | 2/1991 | Rossen | | | 6,824,515 | B2 | 11/2004 | Suorsa et al. |
| 5,014,699 | A | 5/1991 | Pollack et al. | | | 6,836,685 | B1 | 12/2004 | Fitz |
| 5,061,234 | A | 10/1991 | Chaney | | | 6,858,000 | B1 | 2/2005 | Schukin et al. |
| 5,113,859 | A | 5/1992 | Funke | | | 6,866,678 | B2 | 3/2005 | Shenderova et al. |
| 5,277,694 | A | 1/1994 | Leysieffer et al. | | | 6,871,099 | B1 | 3/2005 | Whitehurst et al. |
| 5,300,093 | A | 4/1994 | Koestner et al. | | | 6,887,239 | B2 | 5/2005 | Elstrom et al. |
| 5,476,438 | A | 12/1995 | Edrich et al. | | | 6,889,085 | B2 | 5/2005 | Dawson |
| 5,479,934 | A * | 1/1996 | Imran | | A61B 5/0017 600/390 | 6,921,413 | B2 | 7/2005 | Mahadevan-Jansen et al. |
| 5,545,124 | A | 8/1996 | Krause et al. | | | 6,934,580 | B1 | 8/2005 | Osorio et al. |
| 5,551,953 | A | 9/1996 | Lattin et al. | | | 6,937,906 | B2 | 8/2005 | Terry et al. |
| 5,569,591 | A | 10/1996 | Kell et al. | | | 6,941,171 | B2 | 9/2005 | Mann et al. |
| 5,575,761 | A | 11/1996 | Hajianpour | | | 6,964,643 | B2 | 11/2005 | Hovland et al. |
| 5,582,586 | A | 12/1996 | Tachibana et al. | | | 6,970,744 | B1 | 11/2005 | Shelchuk |
| 5,713,922 | A | 2/1998 | King | | | 6,976,998 | B2 | 12/2005 | Rizzo et al. |
| 5,738,625 | A | 4/1998 | Gluck | | | 7,002,790 | B2 | 2/2006 | Hossick-Schott et al. |
| 5,776,170 | A | 7/1998 | MacDonald et al. | | | 7,003,352 | B1 | 2/2006 | Whitehurst |
| 5,776,171 | A | 7/1998 | Peckham et al. | | | 7,013,177 | B1 | 3/2006 | Whitehurst et al. |
| D398,403 | S * | 9/1998 | Bishop | | D24/231 | 7,058,447 | B2 | 6/2006 | Hill et al. |
| 5,893,883 | A | 4/1999 | Torgerson et al. | | | 7,104,947 | B2 | 9/2006 | Riehl |
| 5,895,416 | A | 4/1999 | Barreras, Sr. et al. | | | 7,120,497 | B2 | 10/2006 | Ben-Haim et al. |
| 5,925,070 | A | 7/1999 | King et al. | | | 7,146,210 | B2 | 12/2006 | Palti |
| 5,975,085 | A | 11/1999 | Rise | | | 7,173,130 | B2 | 2/2007 | Tsien et al. |
| 6,021,348 | A | 2/2000 | James | | | 7,283,861 | B2 | 10/2007 | Bystritsky |
| 6,035,236 | A | 3/2000 | Jarding et al. | | | D630,766 | S * | 1/2011 | Harbin D24/231 |
| 6,066,084 | A | 5/2000 | Edrich et al. | | | 7,894,903 | B2 | 2/2011 | John |
| 6,066,163 | A | 5/2000 | John | | | 8,197,409 | B2 | 6/2012 | Foley et al. |
| 6,081,744 | A | 6/2000 | Loos | | | 8,718,758 | B2 | 5/2014 | Wagner et al. |
| 6,091,992 | A | 7/2000 | Bourgeois et al. | | | 8,929,979 | B2 | 1/2015 | Wagner et al. |
| 6,094,598 | A | 7/2000 | Elsberry et al. | | | D750,264 | S * | 2/2016 | Guarraia D24/200 |
| 6,102,875 | A | 8/2000 | Jones | | | D750,794 | S * | 3/2016 | Guarraia D24/200 |
| 6,110,080 | A * | 8/2000 | Niv | | A63B 21/065 2/171.2 | 2001/0051774 | A1 | 12/2001 | Littrup et al. |
| 6,128,537 | A | 10/2000 | Rise | | | 2004/0131998 | A1 | 7/2004 | Marom et al. |
| 6,161,030 | A * | 12/2000 | Levendowski | | A61B 5/0478 600/383 | 2005/0003380 | A1 | 1/2005 | Cohen et al. |
| 6,161,048 | A | 12/2000 | Sluijter et al. | | | 2005/0043726 | A1 | 2/2005 | McHale et al. |
| 6,169,403 | B1 | 1/2001 | Hebrank et al. | | | 2005/0043762 | A1 | 2/2005 | Echt et al. |
| 6,205,356 | B1 | 3/2001 | Holcomb | | | 2005/0202489 | A1 | 9/2005 | Cho et al. |
| D441,111 | S * | 4/2001 | Van Der Bel | | D24/231 | 2006/0004422 | A1 | 1/2006 | De Ridder |
| 6,221,908 | B1 | 4/2001 | Kilgard et al. | | | 2006/0017749 | A1 | 1/2006 | McIntyre et al. |
| D441,886 | S * | 5/2001 | Beck | | D24/231 | 2006/0247104 | A1 | 11/2006 | Grabiner et al. |
| 6,231,527 | B1 | 5/2001 | Sol | | | 2006/0257893 | A1 | 11/2006 | Takahashi et al. |
| 6,231,604 | B1 | 5/2001 | von Ilberg | | | 2007/0060974 | A1 | 3/2007 | Lozano |
| 6,234,953 | B1 | 5/2001 | Thomas et al. | | | 2007/0156180 | A1 | 7/2007 | Jaax et al. |
| 6,275,735 | B1 | 8/2001 | Jarding et al. | | | 2007/0299370 | A1 | 12/2007 | Bystritsky |
| 6,275,737 | B1 | 8/2001 | Mann | | | 2008/0039895 | A1 | 2/2008 | Fowler et al. |
| 6,330,476 | B1 | 12/2001 | Ben-Haim et al. | | | 2008/0046053 | A1 | 2/2008 | Wagner et al. |
| 6,375,666 | B1 | 4/2002 | Mische | | | 2008/0077199 | A1 * | 3/2008 | Shefi A61N 5/0613 607/88 |
| 6,390,995 | B1 | 5/2002 | Ogden et al. | | | 2008/0124726 | A1 | 5/2008 | Monforte |
| 6,393,325 | B1 | 5/2002 | Mann et al. | | | 2008/0228110 | A1 | 9/2008 | Berne |
| 6,408,211 | B1 | 6/2002 | Powell | | | 2009/0018599 | A1 | 1/2009 | Hastings et al. |
| 6,432,070 | B1 | 8/2002 | Talish et al. | | | 2009/0240170 | A1 | 9/2009 | Rowley et al. |
| 6,463,328 | B1 | 10/2002 | John | | | 2010/0070006 | A1 | 3/2010 | Wagner et al. |
| 6,468,274 | B1 | 10/2002 | Alleyne et al. | | | 2010/0125190 | A1 * | 5/2010 | Fadem A61B 5/0478 600/383 |
| 6,491,039 | B1 | 12/2002 | Dobak, III | | | 2010/0268287 | A1 | 10/2010 | Celnik |
| | | | | | | 2011/0245734 | A1 | 10/2011 | Wagner et al. |
| | | | | | | 2011/0275927 | A1 | 11/2011 | Wagner et al. |
| | | | | | | 2012/0143020 | A1 * | 6/2012 | Bordoley A61B 5/1114 600/301 |
| | | | | | | 2012/0289869 | A1 * | 11/2012 | Tyler A61N 7/00 601/2 |
| | | | | | | 2014/0249385 | A1 * | 9/2014 | Wada A61B 5/0478 |

(56)

References Cited

U.S. PATENT DOCUMENTS

| | | | | | |
|--------------|-----|---------|-----------|---------|--------------|
| 2015/0112153 | A1* | 4/2015 | Nahum | 600/301 | A61B 5/6803 |
| 2015/0133718 | A1* | 5/2015 | Schneider | 600/301 | A61N 2/006 |
| 2015/0257674 | A1* | 9/2015 | Jordan | 600/14 | A61B 5/0006 |
| 2015/0282760 | A1* | 10/2015 | Badower | 600/383 | A61B 5/04012 |
| | | | | 600/383 | |

FOREIGN PATENT DOCUMENTS

| | | | |
|----|-------------|----|--------|
| WO | 2010/009141 | A1 | 1/2010 |
| WO | 2010/017392 | A2 | 2/2010 |
| WO | 2012/101093 | A2 | 8/2012 |
| WO | 2013/054257 | A1 | 4/2013 |

OTHER PUBLICATIONS

- Allen, E.A., et al., Transcranial magnetic stimulation elicits coupled neural and hemodynamic consequences. *Science*, 2007. 317(5846): p. 1918-21.
- Aydin-Abidin, S., et al., Effects of repetitive TMS on visually evoked potentials and EEG in the anesthetized cat: dependence on stimulus frequency and train duration. *J Physiol*, 2006:443-455.
- Benabid, A.L., et al., Deep brain stimulation of the corpus luyisi (subthalamic nucleus) and other targets in Parkinson's disease. Extension to new indications such as dystonia and epilepsy. *J Neurol*, 2001. 248 Suppl 3: p. III37-47.
- Bindman LJ, L.O., Redfearn JW. , Long-lasting changes in the level of the electrical activity of the cerebral cortex produced by polarizing currents. *Nature* 1962. 196:584-85.
- Bindman, L.J., O.C. Lippold, and J.W. Redfearn, The Action of Brief Polarizing Currents on the Cerebral Cortex of the Rat (1) During Current Flow and (2) in the Production of Long-Lasting after-Effects. *J Physiol*, 1964. 172:369-82.
- Bostock, H., The strength-duration relationship for excitation of myelinated nerve: computed dependence on membrane parameters. *J Physiol*, 1983. 341: p. 59-74.
- Boyden, E.S., et al., Millisecond-timescale, genetically targeted optical control of neural activity. *Nat Neurosci*, 2005. 8(9):1263-8.
- Brice, J. and L. McLellan, Suppression of intention tremor by contingent deep-brain stimulation. *Lancet*, 1980. 1(8180):1221-2.
- Britten, K.H. and R.J. van Wezel, Electrical microstimulation of cortical area MST biases heading perception in monkeys. *Nat Neurosci*, 1998. 1(1):59-63.
- Brown, J.A., et al., Motor cortex stimulation for the enhancement of recovery from stroke: a prospective, multicenter safety study. *Neurosurgery*, 2006. 58(3): p. 464-73.
- Butovas, S. and C. Schwarz, Spatiotemporal effects of microstimulation in rat neocortex: a parametric study using multielectrode recordings. *J Neurophysiol*, 2003. 90(5):3024-39.
- Butson CR, McIntyre CC (2005) Tissue and electrode capacitance reduce neural activation volumes during deep brain stimulation. *Clin Neurophysiol* 116:2490-2500.
- Butson, C.R. and C.C. McIntyre, Role of electrode design on the volume of tissue activated during deep brain stimulation. *J Neural Eng*, 2006. 3(1): p. 1-8.
- Butson, C.R. And C.C. McIntyre. Deep brain Stimulation of the the subthalamic nucleus: model-based analysis of the effects of electrode capacitance on the volume of activation. in 2nd International IEEE EMBS Conference on Neural Engineerin. 2005. Arlington, VA: IEEE.
- Carbunaru, R. and D.M. Durand, Toroidal coil models for transcutaneous magnetic stimulation of nerves. *IEEE Trans Biomed Eng*, 2001. 48(4):434-41.
- Chew, W.C. and P.N. Sen, Dielectric enhancement due to an electrochemical double layer: thin double layer approximation. *J. Chem. Phys.*, 1982. 77:4683.
- Chew, W.C., 1983, Dielectric enhancement and electrophoresis due to electrochemical double layer: A uniform approximation. *J Chem Phys*. 80(9):4541-4552.
- Clement, G.T. and K. Hynynen, A non-invasive method for focusing ultrasound through the human skull. *Phys Med Biol*, 2002. 47(8):1219-36.
- Clement, G.T., et al., A magnetic resonance imaging-compatible, large-scale array for trans-skull ultrasound surgery and therapy. *J Ultrasound Med*, 2005. 24(8):1117-25.
- Clement, G.T., Perspectives in clinical uses of high-intensity focused ultrasound. *Ultrasonics*, 2004. 42(10):1087-93.
- Cohen, D. and B.N. Cuffin, Developing a more focal magnetic stimulator. Part 1: some basic principles. *Journal of Clinical Neurophysiology*, 1991. 8:102-111.
- Cohen, L.G., et al., Effects of coil design on delivery of focal magnetic stimulation. Technical considerations. *Electroencephalogr Clin Neurophysiol*, 1990. 75(4):350-7.
- Cohen, M.R. and W.T. Newsome, What electrical microstimulation has revealed about the neural basis of cognition. *Curr Opin Neurobiol*, 2004. 14(2):169-77.
- Connor, C.W. and K. Hynynen, Patterns of Thermal Deposition in the Skull During Transcranial Focused Ultrasound Surgery. *IEEE Trans Biomed Eng*, 2004. 51(10):1693-1706.
- Connor, C.W., G.T. Clement, and K. Hynynen, A unified model for the speed of sound in cranial bone based on genetic algorithm optimization. *Phys Med Biol*, 2002. 47(22):3925-44.
- Cramer, S.C., et al., Use of functional MRI to guide decisions in a clinical stroke trial. *Stroke*, 2005. 36(5):e50-2.
- Deuschl, G., et al., Deep brain stimulation: postoperative issues. *Mov Disord*, 2006. 21 Suppl 14:S219-37.
- Di Lazzaro, V., et al., The physiological basis of transcranial motor cortex stimulation in conscious humans. *Clin Neurophysiol*, 2004. 115(2):255-66.
- Diamond, A. and J. Jankovic, The effect of deep brain stimulation on quality of life in movement disorders. *J Neurol Neurosurg Psychiatry*, 2005. 76(9):1188-93.
- Diokno, A.C., P.B. Leu, and D.B. Konstandt, A simplified method of implanting a neuromodulator device. *J Urol*, 2003. 169(4):1466-9.
- Dissado, L.A., A fractal interpretation of the dielectric response of animal tissues. *Phys. Med. Biol.*, 1990. 35(11):1487-1503.
- Ditterich, J., M.E. Mazurek, and M.N. Shadlen, Microstimulation of visual cortex affects the speed of perceptual decisions. *Nat Neurosci*, 2003. 6(8):891-8.
- Donald I. McRee, Howard Wachtel, Pulse Microwave Effects on Nerve Vitality, *Radiation Research*, vol. 91, No. 1, (1982):212-218.
- Duck, F.A., Medical and non-medical protection standards for ultrasound and infrasound. *Prog Biophys Mol Biol*, 2007. 93(1-3):176-91.
- Durand, D. and M. Bikson, Suppression and control of epileptiform activity by electrical stimulation: a review. *Proceedings of the IEEE*, 2001. 89(7):1065-1082.
- Eaton, H., Electric field induced in a spherical volume conductor from arbitrary coils: applications to magnetic stimulation and MEG. *Medic Biol Eng Comput*, 1992:433-440.
- Esselle, K. and M. Stuchly, Neural stimulation with magnetic fields: analysis of induced electrical fields. *IEEE Transactions on Biomedical Engineering*, 1992. 39:693-700.
- Extended European Search Report for Application No. 12826175.7 dated Mar. 9, 2015 (6 pages).
- Extended Supplementary European Search Report for Application No./Patent No. 12752660.6 dated Jul. 9, 2014 (6 pages).
- Fields, J.A., et al., Neuropsychological and quality of life outcomes 12 months after unilateral thalamic stimulation for essential tremor. *J Neurol Neurosurg Psychiatry*, 2003. 74(3):305-11.
- Fixman, M., Charged macromolecules in external fields. I. The sphere. *J Chem Phys*, 1980. 72(9):5177-5186.
- Fixman, M., Thin double layer approximation for electrophoresis and dielectric respons. *J Chem Phys*, 1982. 78(3):1483-1492.
- FralexTherapeutics, Fralex Provides Update on Relief Trial. 2008: Toronto, (Downloaded from the Internet May 25 , 2013).
- Fregni, F. and A. Pascual-Leone, Technology insight: noninvasive brain stimulation in neurology-perspectives on the therapeutic potential of rTMS and tDCS. *Nat Clin Pract Neurol*, 2007. 3(7):383-93.

(56)

References Cited

OTHER PUBLICATIONS

- Fry WJ, W.V., Tucker D, Fry FJ, Physical factors involved in ultrasonically induced changes in living systems: I. Identification of non-temperature effects. *J Acoust Soc Am* 1950. 22:867-876.
- Fry, E.J., An ultrasonic projector design for a wide range of research applications. *Rev Sci Instrum*, 1950. 21(11):940-1.
- Fry, W. J., Electrical Stimulation of Brain Localized Without Probes—Theoretical Analysis of a Proposed Method, *J Acoust Soc AM* 44(4):919-31 (1968).
- Fry, W.J., Use of intense ultrasound in neurological research. *Am J Phys Med*, 1958. 37(3):143-7.
- Gabriel, C., S. Gabriel, and E. Corthout, The dielectric properties of biological tissues: I. Literature survey. *Phys Med Biol*, 1996. 41(11):2231-49.
- Thomas, A.W., D.J. Drost, and F.S. Prato, Human subjects exposed to a specific pulsed (200 microT) magnetic field: effects on normal standing balance. *Neurosci Lett*, 2001. 297(2):121-4.
- Tofts, P.S., The distribution of induced currents in magnetic stimulation of the nervous system. *Physical Medicine and Biology*, 1990. 35:1119-1128.
- Tranchina, D. and C. Nicholson, A model for the polarization of neurons by extrinsically applied electric fields. *Biophys J*, 1986. 50(6):1139-56.
- Traub RD, (1977), Motoneurons of different geometry and the size principle. *Biol Cybern* 25:163-176.
- Troster, A.I., et al., Neuropsychological deficits in essential tremor: an expression of cerebello-thalamo-cortical pathophysiology? *Eur J Neurol*, 2002. 9(2):143-51.
- Tyler, W.J., et al., Remote excitation of neuronal circuits using low-intensity, low-frequency ultrasound. *PLoS One*, 2008. 3(10):e3511.
- Ueno, S., T. Tashiro, and K. Harada, Localised stimulation of neural tissues in the brain by means of a paired configuration of time-varying magnetic fields. *J. Appl. Phys.*, 1988. 64:5862-5864.
- Wagner T, Valero-Cabre A, Pascual-Leone A, (2007), Noninvasive Human Brain Stimulation. *Annu Rev Biomed Eng.*, 7.1:19.1-19.39.
- Wagner TA, Zahn M, Grodzinsky AJ, Pascual-Leone A, (2004), Three-dimensional head model simulation of transcranial magnetic stimulation. *IEEE Trans Biomed Eng* 51:1586-1598.
- Wagner, T., et al., Biophysical foundations underlying TMS: Setting the stage for an effective use of neurostimulation in the cognitive neurosciences. *Cortex* 45, 2008:1025-1034.
- Wagner, T., et al., Transcranial direct current stimulation: a computer-based human model study. *Neuroimage*, 2007. 35(3):1113-24.
- Wagner, T., et al., Transcranial magnetic stimulation and brain atrophy: a computer-based human brain model study. *Exp Brain Res* 189, 2008:539-550.
- Wagner, T., et al., Transcranial magnetic stimulation and stroke: a computer-based human model study. *Neuroimage*, 2006. 30(3):857-70.
- Wagner, T., Field distributions within the human cortex induced by transcranial magnetic stimulation, in *EECS*. 2001, Massachusetts Institute of Technology: Cambridge., Chapters 1 and 2, (126 pages).
- Warman, E.N., W.M. Grill, and D. Durand, Modeling the effects of electric fields on nerve fibers: determination of excitation thresholds. *IEEE Trans Biomed Eng*, 1992. 39(12):1244-54.
- Wichmann, T. and M.R. Delong, Deep brain stimulation for neurologic and neuropsychiatric disorders. *Neuron*, 2006. 52(1):197-204.
- Wininger, F.A., J.L. Schei, and D.M. Rector, Complete optical neurophysiology: toward optical stimulation and recording of neural tissue. *Appl Opt*, 2009. 48(10):D218-24.
- Wobschall, D., Bilayer Membrane Elasticity and Dynamic Response. *Journal of Colloid and Interface Science*, 1971. 36(3):385-396.
- Wobschall, D., Voltage Dependence of Bilayer Membrane Capacitance. *Journal of Colloid and Interface Science*, 1972. 40(3):417-423.
- Wongsarnpigoon, A. and W.M. Grill, Computational modeling of epidural cortical stimulation. *J Neural Eng*, 2008. 5(4):443-54
- Zangen, A., et al., Transcranial magnetic stimulation of deep brain regions: evidence for efficacy of the H-coil. *Clin Neurophysiol*, 2005. 116(4):775-9.
- Gabriel, S., R.W. Lau, and C. Gabriel, The dielectric properties of biological tissues: II. Measurements in the frequency range 10 Hz to 20 GHz. *Phys Med Biol*, 1996. 41(11):2251-69.
- Gabriel, S., R.W. Lau, and C. Gabriel, The dielectric properties of biological tissues: III. Parametric models for the dielectric spectrum of tissues. *Phys Med Biol*, 1996. 41(11):2271-93
- Gielen, F. Deep Brain Stimulation: Current Practice and Challenges for the Future. in *1st International IEEE EMBS Conference on Neural Engineering*. 2003. Capri Island, Italy: IEEE.
- Graziano, M.S., C.S. Taylor, and T. Moore, Complex movements evoked by microstimulation of precentral cortex. *Neuron*, 2002. 34(5):841-51.
- Grill, W.M., et al., Temporal excitation properties of paresthesias evoked by thalamic microstimulation. *Clin Neurophysiol*, 2005. 116(5):1227-34.
- Grill, W.M., S.E. Norman, and R.V. Bellamkonda, Implanted neural interfaces: biochallenges and engineered solutions. *Annu Rev Biomed Eng*, 2009. 11:1-24.
- Grosse, C., Permittivity of suspension of charged particles in electrolyte solution. *J. Chem. Phys.*, 1987. 91:3073.
- Gusev, V., et al., Imaging With the Ultrasonic Vibration Potential: A Theory for Current Generation. *Ultrasound in Med. & Biol.*, 2005. vol. 31, No. 2:273-278.
- Haar, G.t., Accoustic Surgery: Bursts of focused ultrasound energy three orders of magnitude more intense than diagnostic ultrasound are emerging as a noninvasive option for treating cancer and other medical procedures., *Physics Today*, 2001:29-34.
- Hart FX, Toll RB, Berner NJ, Bennett NH, (1996), The low frequency dielectric properties of octopus arm muscle measured in vivo. *Phys Med Biol* 41:2043-2052.
- Hart, F.X. and W.R. Dunfree, In vivo measurements of low frequency dielectric spectra of a frog skeletal muscle. *Phys. Med. Biol.*, 1993, 38:1099-1112.
- Hatanaka, N., et al., Input-output organization of jaw movement-related areas in monkey frontal cortex. *J Comp Neurol*, 2005. 492(4):401-25.
- Heller L, Hulsteyn DBv, (1992), Brain stimulation using electromagnetic sources: theoretical aspects. *Biophysical Journal* 63:129-138.
- Hinch, E.J., et al., Dielectric response of a dilute suspension of spheres with thin double layers in an asymmetric electrolyte. *J Chem Soc, Farady Tans.*, 1983. 80:535-551.
- Holdefer, R.N., R. Sadleir, and M.J. Russell, Predicted current densities in the brain during transcranial electrical stimulation. *Clin Neurophysiol*, 2006. 117(6):1388-97.
- Hole, S. and T. Ditchi, Non-destructive Methods for Space Charge Distribution Measurements: What are the Differences? *IEEE EMBS*, 2003. 10(4):670-677.
- Hsiao, I. and V. Lin, Improved coil design for functional magnetic stimulation of expiratory muscles. *IEEE Trans Biomed Eng*, 2001. 48(6):684-694.
- Hsu KH and D. DM., A 3-D differential coil design for localized magnetic stimulation. *IEEE Trans Biomed Eng*, 2001. 48(10):1162-8.
- Jones KE, Bawa P, (1997), Computer simulation of the responses of human motoneurons to composite 1A EPSPs: effects of background firing rate. *J Neurophysiol* 77:405-420.
- Kanai, R., et al., Frequency-dependent electrical stimulation of the visual cortex. *Curr Biol*, 2008. 18(23):1839-43.
- Kanner, A.M., Deep brain stimulation for intractable epilepsy: which target and for which seizures? *Epilepsy Curr*, 2004. 4(6):231-2.
- Kaufman, E.F. and A.C. Rosenquist, Efferent projections of the thalamic intralaminar nuclei in the cat. *Brain Res*, 1985. 335(2):257-79.
- Khachaturian, M.H., et al., Focal reversible deactivation of cerebral metabolism affects water diffusion. *Magn Reson Med*, 2008. 60(5):1178-89.
- Khraiche, M.L., et al., Ultrasound induced increase in excitability of single neurons. *Conf Proc IEEE Eng Med Biol Soc*, 2008. 2008: p. 4246-9.
- Kleim, J.A., T.A. Jones, and T. Schallert, Motor enrichment and the induction of plasticity before or after brain injury. *Neurochem Res*, 2003. 28(11):1757-69.

(56)

References Cited

OTHER PUBLICATIONS

- Komissarow, L., et al., Triple stimulation technique (TST) in amyotrophic lateral sclerosis. *Clin Neurophysiol*, 2004. 115(2):356-60.
- Kraus, K.H., et al., The use of a cap-shaped coil for transcranial magnetic stimulation of the motor cortex. *J Clin Neurophysiol*, 1993. 10(3):353-62.
- Kumar, K., C. Toth, and R.K. Nath, Deep brain stimulation for intractable pain: a 15-year experience. *Neurosurgery*, 1997. 40(4):736-46; Discussion 746-7.
- Larkin, J., et al., Combined electric field and ultrasound therapy as a novel anti-tumour treatment. *European Journal of Cancer* 41 (2005):1339-1348.
- Lemay, M.A., et al., Endpoint forces obtained during intraspinal microstimulation of the cat lumbar spinal cord—experimental and biomechanical model results. in *IEEE 28th Annual Northeast Bioengineering Conference*, 2002, IEEE.
- Li, D.L., et al. Finite element analysis of transcranial electrical stimulation for intraoperative monitoring. in *Bioengineering Conference, Proceedings of the IEEE 31st Annual Northeast 2005*, IEEE.
- Lin, V., I. Hsiao, and V. Dhaka, Magnetic coil design considerations for functional magnetic stimulation. *IEEE Trans Biomed Eng*, 2000. 47(5):600-610.
- Lomber, S.G., The advantages and limitations of permanent or reversible deactivation techniques in the assessment of neural function. *J Neurosci Methods*, 1999. 86(2):109-17.
- Lozano, A.M., et al., Deep brain stimulation for Parkinson's disease: disrupting the disruption. *Lancet Neurol*, 2002. 1(4):225-31.
- Luber, B., et al., Remediation of sleep-deprivation-induced working memory impairment with fMRI-guided transcranial magnetic stimulation. *Cereb Cortex*, 2008. 18(9):2077-85.
- McCreery D, Agnew W, (1990), Neuronal and axonal injury during functional electrical stimulation; a review of the possible mechanisms. In: *Annual International Conference of the IEEE Engineering in Medicine and Biology Society*, p. 1489:IEEE.
- McCreery, D., et al., Accessing the Tonotopic Organization of the Ventral Cochlear Nucleus by Intranuclear Microstimulation. *IEEE Trans Rehabil Eng*, 1998. 6(4):391-399.
- McCreery, D., et al., Charge Density and Charge Per Phase as Cofactors in Neural Injury Induced by Electrical Stimulation. *IEEE Trans Biomed Eng*, 1990. 37(10):996-1001.
- McIntyre, C.C. and W.M. Grill, Excitation of central nervous system neurons by nonuniform electric fields. *Biophys J*, 1999. 76(2):878-88.
- McIntyre, C.C. and W.M. Grill, Extracellular stimulation of central neurons: influence of stimulus waveform and frequency on neuronal output. *J Neurophysiol*, 2002. 88(4):1592-604.
- McIntyre, C.C., et al., Cellular effects of deep brain stimulation: model-based analysis of activation and inhibition. *J Neurophysiol*, 2004. 91(4):1457-69.
- McIntyre, C.C., et al., Electric field and stimulating influence generated by deep brain stimulation of the subthalamic nucleus. *Clin Neurophysiol*, 2004. 115(3):589-95.
- McNeal DR, (1976), Analysis of a model for excitation of myelinated nerve. *IEEE Trans Biomed Eng* 23:329-337.
- McRee, D.I. and H. Wachtel, Elimination of microwave effects on the vitality of nerves after blockage of active transport *Radiat Res*, 1986. 108(3):260-8.
- McRee, D.I. and H. Wachtel, Pulse microwave effects on nerve vitality. *Radiat Res*, 1982. 91(1):212-8.
- McRee, D.I. and H. Wachtel, The effects of microwave radiation on the vitality of isolated frog sciatic nerves. *Radiat Res*, 1980. 82(3):536-46.
- Medtronic, *Activa® PC Implant Manual*, Medtronic, Editor. 2007, Medtronic: Minneapolis.
- Mihran, R.T., et al., Temporally-Specific Modification of Myelinated Axon Excitability In Vitro Following a Single Ultrasound Pulse. *Ultrasound in Med. & Biol.*, 1990, vol. 16, No. 3:297-309.
- Miocinovic, S. and W.M. Grill, Sensitivity of temporal excitation properties to the neuronal element activated by extracellular stimulation. *J Neurosci Methods*, 2004. 132(1):91-9.
- Miranda, P.C., M. Hallett, and P.J. Basser, The electric field induced in the brain by magnetic stimulation: a 3-D finite-element analysis of the effect of tissue heterogeneity and anisotropy. *IEEE Trans Biomed Eng*, 2003. 50(9):1074-85.
- Miranda, P.C., M. Lomarev, and M. Hallett, Modeling the current distribution during transcranial direct current stimulation. *Clin Neurophysiol*, 2006. 117(7):1623-9.
- Montalibet, A., et al., Electric current generated by ultrasonically induced Lorentz force in biological media. *Med. Biol. Eng. Comput.*, 2001, vol. 39:15-20.
- Mouchawar, G., et al., Magnetic Stimulation of excitable tissue: calculation of induced eddy currents with a three-dimensional finite-element model. *IEEE Transactions on Magnetics*, 1993. 29(6):3355-3357.
- Murasugi, C.M., C.D. Salzman, and W.T. Newsome, Microstimulation in visual area MT: effects of varying pulse amplitude and frequency. *J Neurosci*, 1993. 13(4):1719-29.
- Mushahwar, V.K. and K.W. Horch, Selective activation of muscle groups in the feline hindlimb through electrical microstimulation of the ventral lumbo-sacral spinal cord. *IEEE Trans Rehabil Eng*, 2000. 8(1):11-21.
- Nadeem, M., et al., Computation of electric and magnetic stimulation in human head using the 3-D impedance method. *IEEE Transactions on Biomedical Engineering*, 2003. 50(7):900-907.
- Nagarajan, S. and D.M. Durand, Analysis of magnetic stimulation of a concentric axon in a nerve bundle. *IEEE Transactions on Biomedical Engineering*, 1995. 42(9):926-933.
- Nagarajan, S., D.M. Durand, and E.N. Warman, Effects of induced electric fields on finite neuronal structures: a simulation study. *IEEE Transactions on Biomedical Engineering*, 1993. 40(11):1175-1188.
- Nagarajan, S., et al. Magnetic stimulation of finite neuronal structures. in *Annual International Conference of the IEEE Engineering in Medicine and Biology Society*. 1991: IEEE.
- Nathan, S.S., et al., Determination of current density distributions generated by electrical stimulation of the human cerebral cortex. *Electroencephalogr Clin Neurophysiol*, 1993. 86(3):183-92.
- Neri Accornero et al., 'Visual evoked potentials modulation during direct current cortical polarization', *Experimental Brain Research*, Oct. 19, 2006, vol. 178, No. 2, pp. 261-266.
- Nichols, M.J. and W.T. Newsome, Middle temporal visual area microstimulation influences veridical judgments of motion direction. *J Neurosci*, 2002. 22(21):9530-40.
- Northstar Neurosciences, *Northstar Neuroscience Announces Primary Endpoint Results of Everest Clinical Trial*. 2008: Seattle, (Downloaded from the Internet May 25, 2013).
- Norton, 2003, Can ultrasound be used to stimulate nerve tissue, *BioMedical Engineering OnLine* 2(6):1-9.
- O'Brien, W.D., Jr., Ultrasound-biophysics mechanisms. *Prog Biophys Mol Biol*, 2007. 93(1-3):212-55.
- Pascual-Leone, A., D. Bartres-Faz, and J.P. Keenan, Transcranial magnetic stimulation: studying the brain-behaviour relationship by induction of 'virtual lesions'. *Philos Trans R Soc Lond B Biol Sci*, 1999. 354(1387):1229-38.
- Perlmutter, J.S. and J.W. Mink, Deep Brain Stimulation. *Annu Rev Neurosci*, 2006:229-257.
- Pernot, M., et al., In vivo transcranial brain surgery with an ultrasonic time reversal mirror. *J Neurosurg*, 2007. 106(6):1061-6.
- Plonsey R, Heppner DD, (1967), Considerations of quasi-stationarity in electrophysiological systems. *Bull Math Biophys* 29:657-664.
- Priori, A., Brain polarization in humans: a reappraisal of an old tool for prolonged non-invasive modulation of brain excitability. *Clin Neurophysiol*, 2003. 114(4):589-95.
- Prochazka, A., V.K. Mushahwar, and D.B. McCreery, Neural prostheses. *J Physiol*, 2001. 533(Pt 1):99-109.
- Purpura, D.P. and J.G. McMurtry, Intracellular Activities and Evoked Potential Changes During Polarization of Motor Cortex. *J Neurophysiol*, 1965. 28:166-85.
- Ramos-Estebanez, C. et al., Visual phosphene perception modulated by subthreshold crossmodal sensory stimulation *J Neurosci*, 2007. 27(15):4178-81.

(56)

References Cited

OTHER PUBLICATIONS

- Ranck, J.B., Jr., Which elements are excited in electrical stimulation of mammalian central nervous system: a review. *Brain Res*, 1975. 98(3):417-40.
- Rattay, F., et al., Mechanisms of Electrical Stimulation with Neural Prostheses. *Neuromodulation*, 2003. 6(1):42-56.
- Rezai, A.R., et al., Deep brain stimulation for Parkinson's disease: surgical issues. *Mov Disord*, 2006. 21 Suppl 14:S197-218.
- Romo, R., et al., Somatosensory discrimination based on cortical microstimulation. *Nature*, 1998. 392(6674):387-90.
- Rousche, P. and R. Normann, Chronic Intracortical Microstimulation (ICMS) of Cat Sensory Cortex Using the Utah Intracortical Electrode Array. *IEEE Trans Rehabil Eng*, 1999. 7(1):56-68.
- Rush, S. and D.A. Driscoll, Current distribution in the brain from surface electrodes. *Anesth Analg*, 1968. 47(6):717-23.
- Rutten, W.L.C., et al., The influence of ultrasound and ultrasonic focusing on magnetic and electric peripheral nerve stimulation., in *Advances in Magnetic Stimulation: Mathematical modeling and clinical applications*, J. Nilsson, M. Panizza, and F. Grandori, Editors. 1996: Pavia, Italy, (p. 152).
- Salzman, C.D., et al., Microstimulation in visual area MT: effects on direction discrimination performance. *J Neurosci*, 1992. 12(6):2331-55.
- Salzman, C.D., K.H. Britten, and W.T. Newsome, Cortical microstimulation influences perceptual judgements of motion direction. *Nature*, 1990. 346(6280):174-7.
- Saypol, J.M., et al., A theoretical comparison of electric and magnetic stimulation of the brain. *Annals of Biomedical Engineering*, 1991. 19(3):317-28.
- Schmidt, E.M., et al., Feasibility of a visual prosthesis for the blind based on intracortical microstimulation of the visual cortex. *Brain*, 1996. 119 (Pt 2):507-22.
- Schwartzbaum, J.S., Electrophysiology of taste, feeding and reward in lateral hypothalamus of rabbit. *Physiol Behav*, 1988. 44(4-5):507-26.
- Schwarz, G.J., A Theory of the Low Frequency Dielectric Dispersion of Colloidal Particles in Electrolyte Solutions, *J Phys Chem*, 1962. 66:2636.
- Scivill, I., A.T. Barker, and I.L. Freeston, Finite element modelling of magnetic stimulation of the spine. *Proceedings 18th annual international conference of the IEEE engineering in medicine and biology society*, 1996:393-394.
- Seidemann, E. and W.T. Newsome, Effect of spatial attention on the responses of area MT neurons. *J Neurophysiol*, 1999. 81(4):1783-94.
- Seidemann, E., et al., Color signals in area MT of the macaque monkey. *Neuron*, 1999. 24(4):911-7.
- Shupak, N.M., et al., Exposure to a specific pulsed low-frequency magnetic field: a double-blind placebo-controlled study of effects on pain ratings in rheumatoid arthritis and fibromyalgia patients. *Pain Res Manag*, 2006. 11(2):85-90.
- Spiegel, R.J., et al., Measurement of small mechanical vibrations of brain tissue exposed to extremely-low-frequency electric fields. *Bioelectromagnetics*, 1986. 7(3):295-306.
- Stecker, M.M., T. Patterson, and B.L. Netherton, Mechanisms of electrode induced injury. Part 1: theory. *Am J Electroneurodiagnostic Technol*, 2006. 46(4):315-42.
- Stojanovic, M.P. and S. Abdi, Spinal cord stimulation. *Pain Physician*, 2002. 5(2):156-66.
- Stoney, S.D., Jr., W.D. Thompson, and H. Asanuma, Excitation of pyramidal tract cells by intracortical microstimulation: effective extent of stimulating current. *J Neurophysiol*, 1968. 31(5):659-69.
- Tehovnik, E.J. and W.M. Slocum, Microstimulation of V1 affects the detection of visual targets: manipulation of target contrast. *Exp Brain Res*, 2005. 165(3):305-14.
- Tehovnik, E.J., Electrical stimulation of neural tissue to evoke behavioral responses. *J Neurosci Methods*, 1996. 65(1):1-17.
- Terzuolo, C.A. and T.H. Bullock, Measurement of Imposed Voltage Gradient Adequate to Modulate Neuronal Firing. *Proc Natl Acad Sci U S A*, 1956. 42(9):687-694.
- Thickbroom, G.W., Transcranial magnetic stimulation and synaptic plasticity: experimental framework and human models. *Exp Brain Res*, 2007. 180(4):583-93.
- International Search Report for PCT/US2009/053006 dated Mar. 18, 2010 (3 pages).
- Roth, B.J., Mechanisms for electrical stimulation of excitable tissue. *Critical Reviews in Biomedical Engineering*, 1994. 22(3-4):253-305.

* cited by examiner

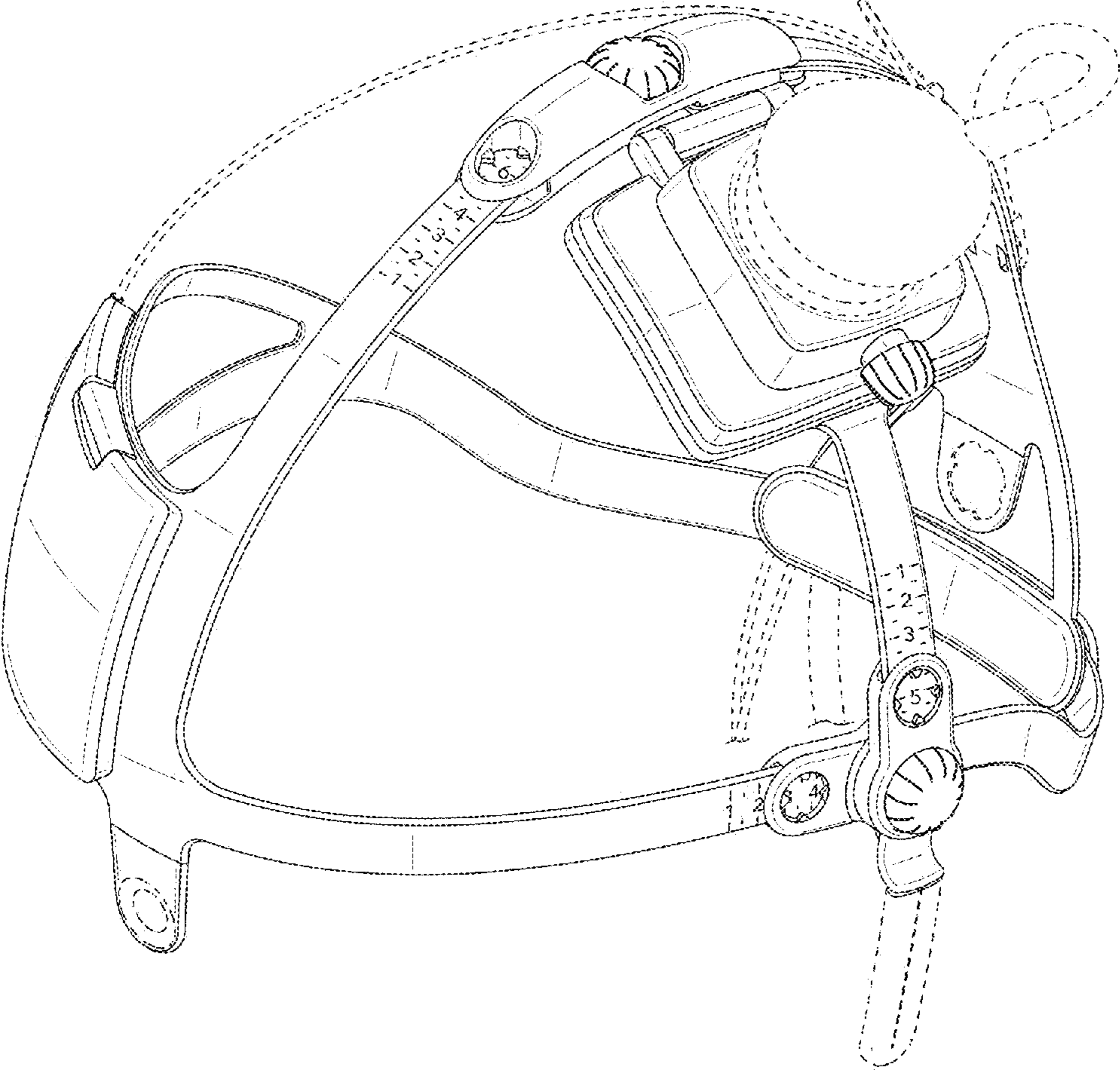

FIG.1

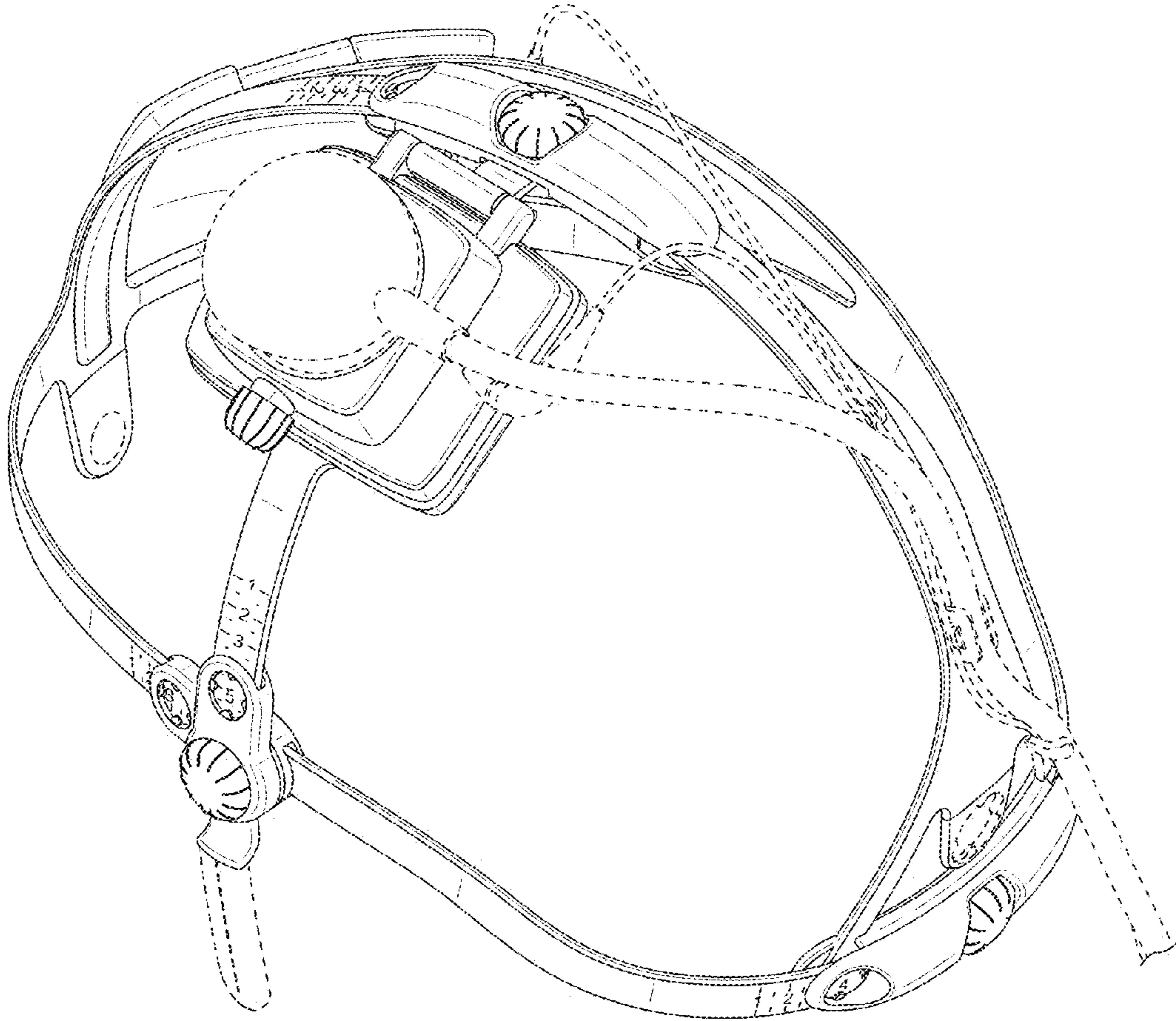

FIG.2

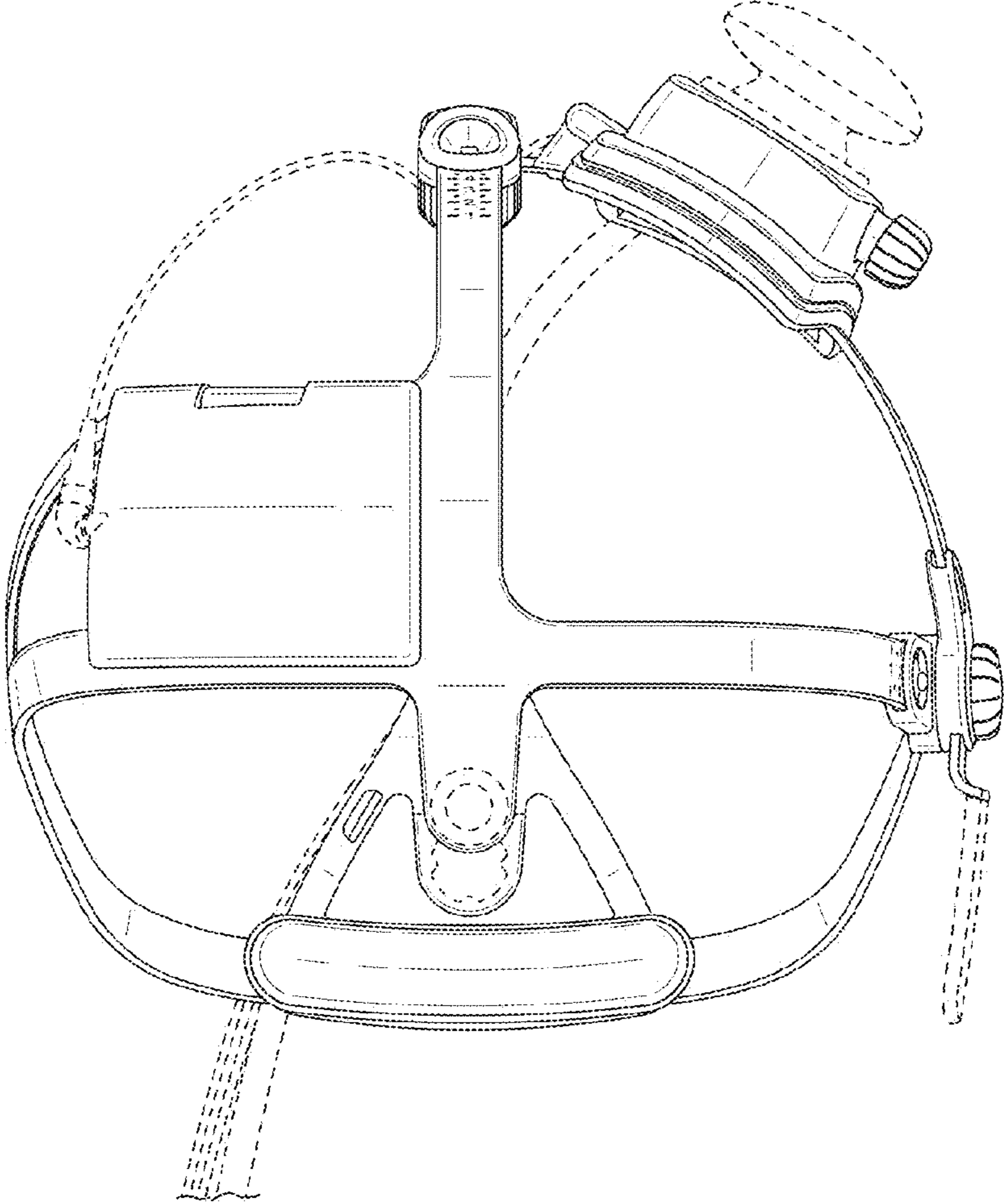

FIG.3

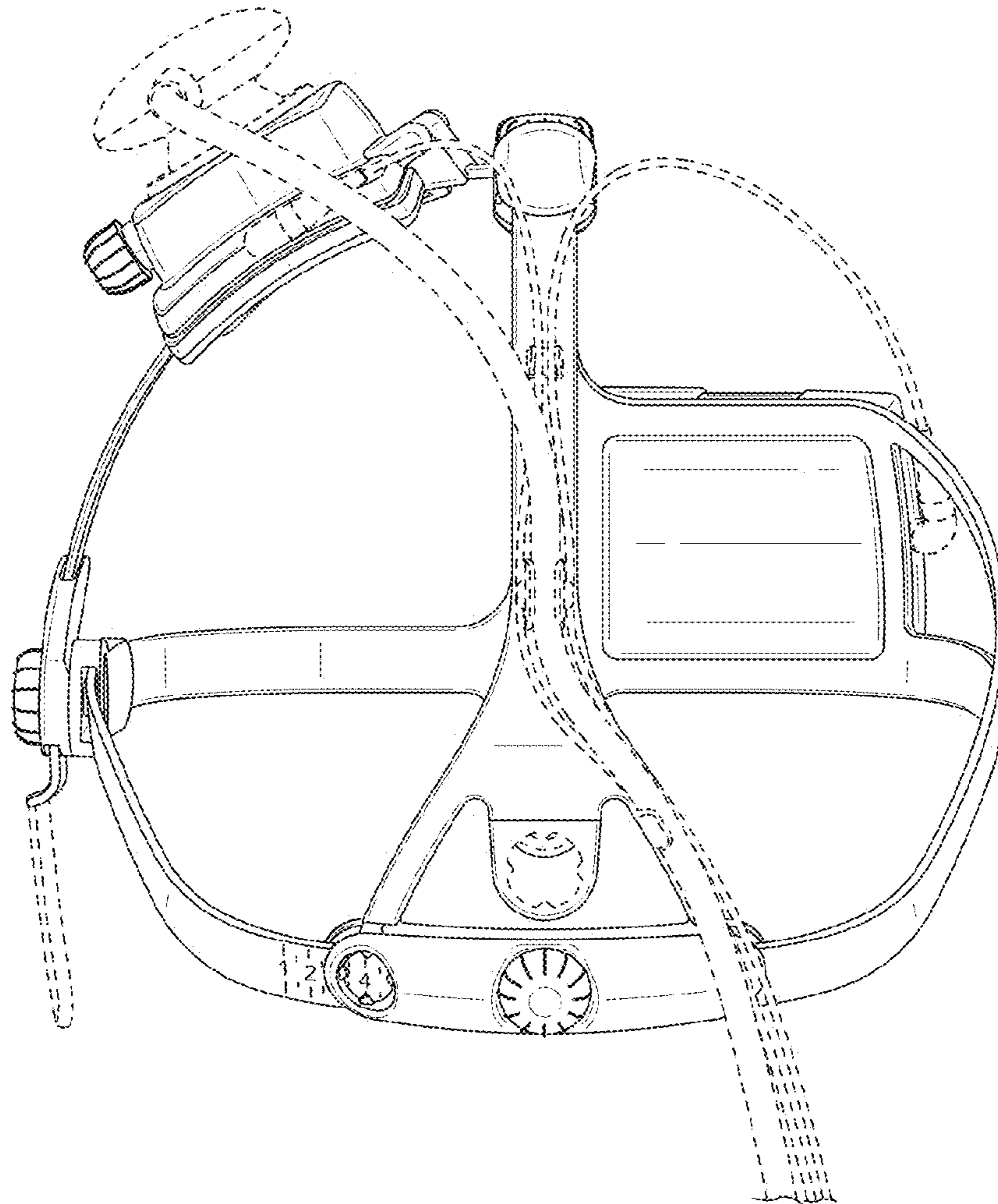

FIG.4

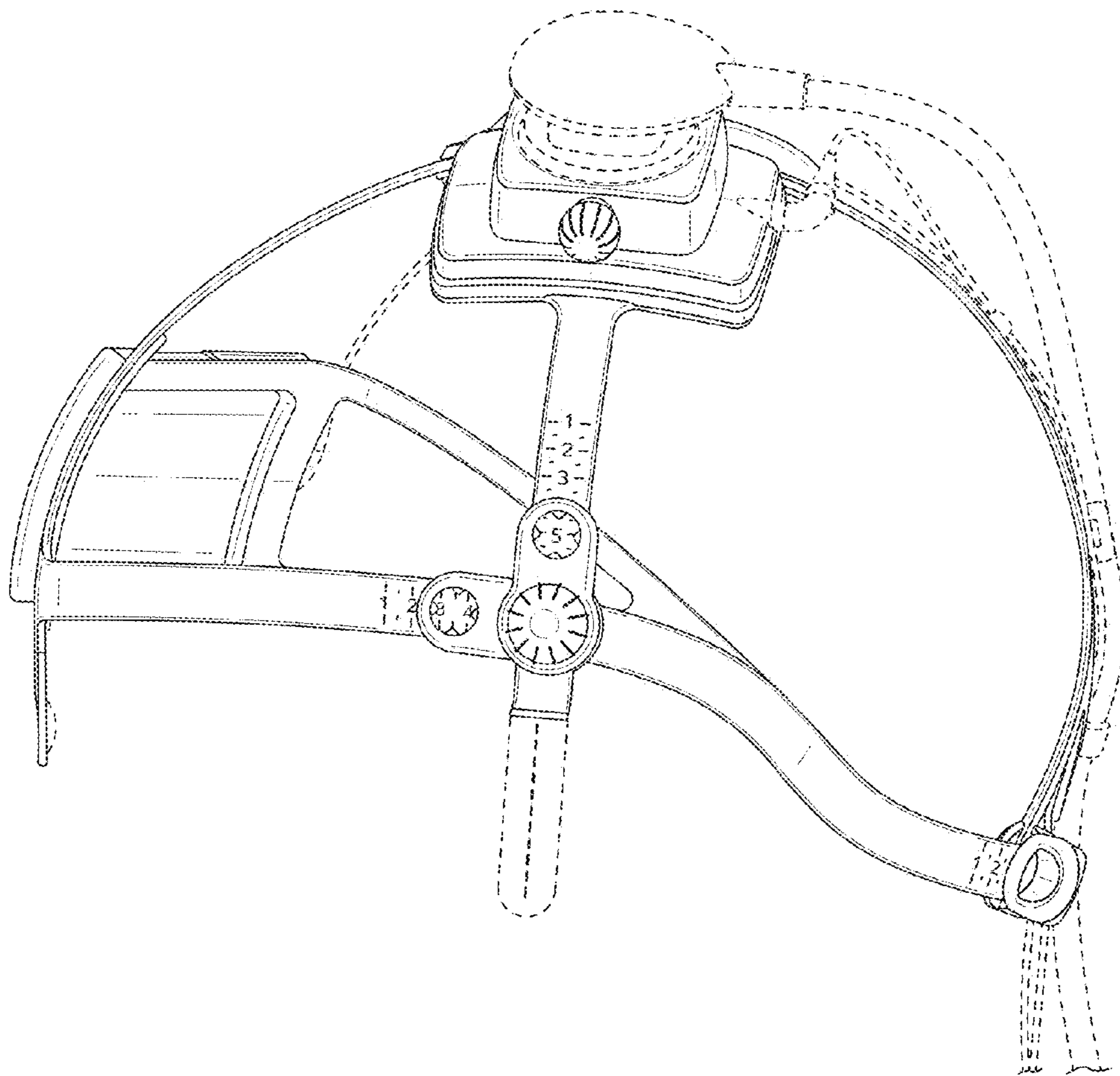

FIG.5

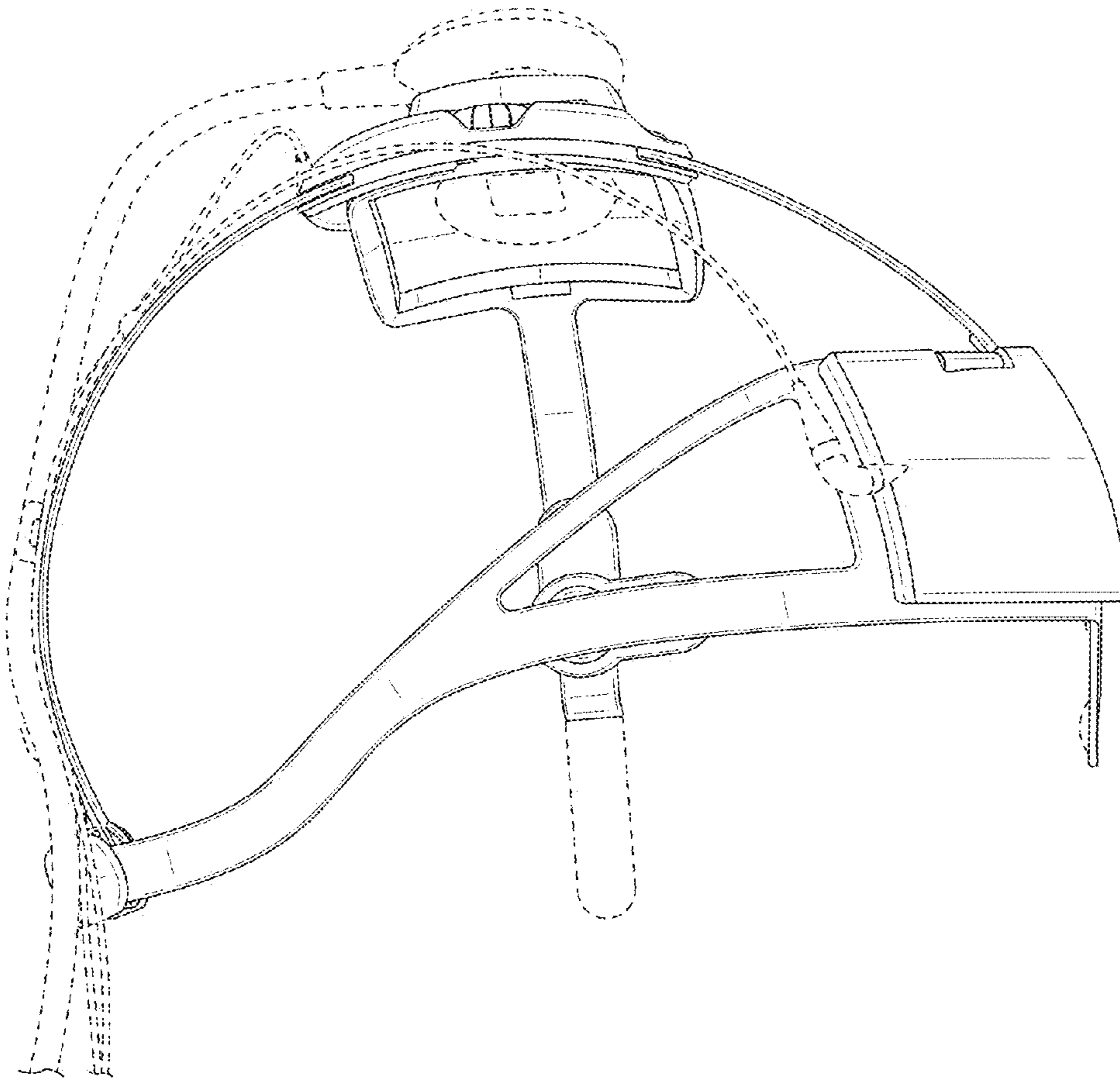

FIG.6

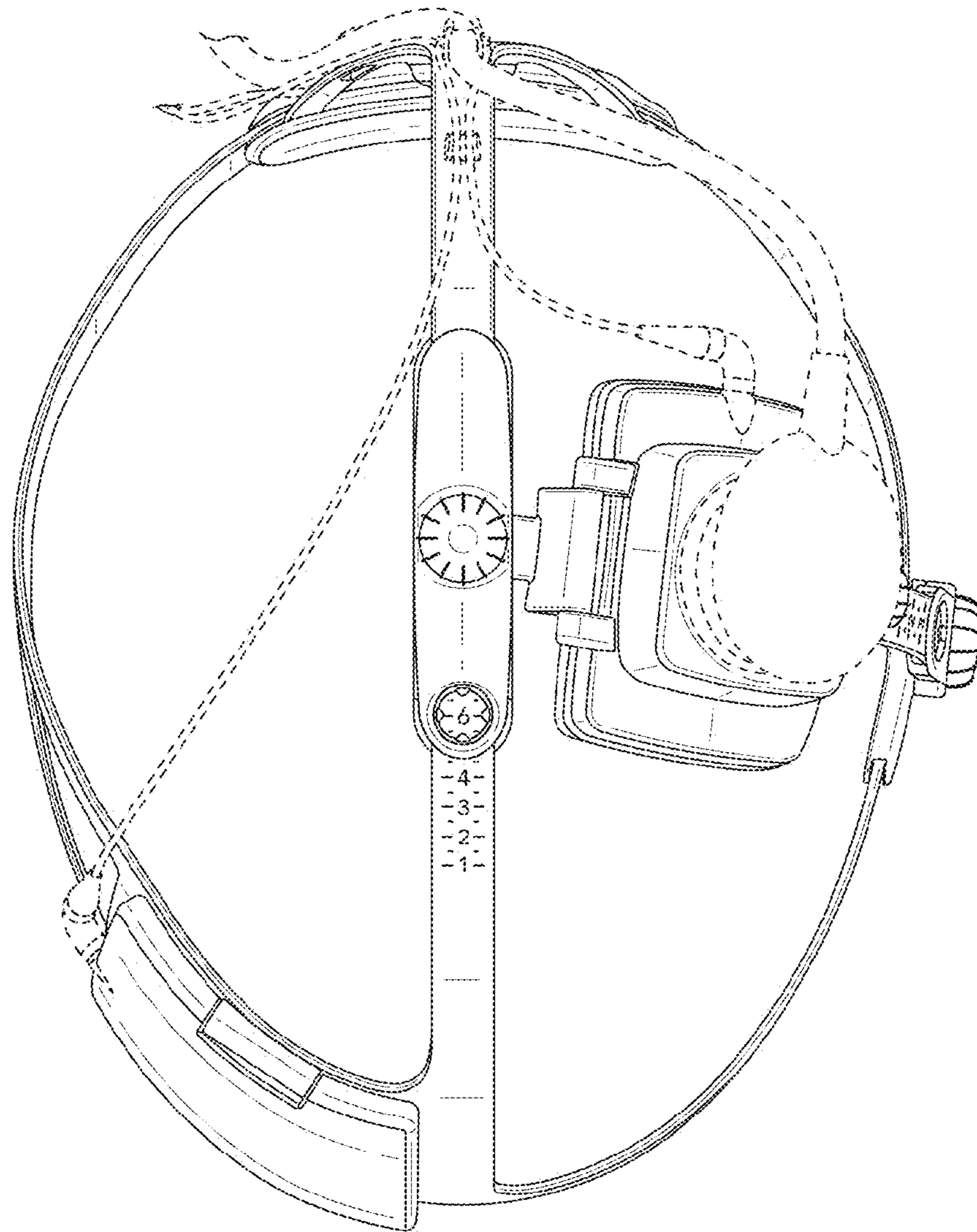

FIG.7

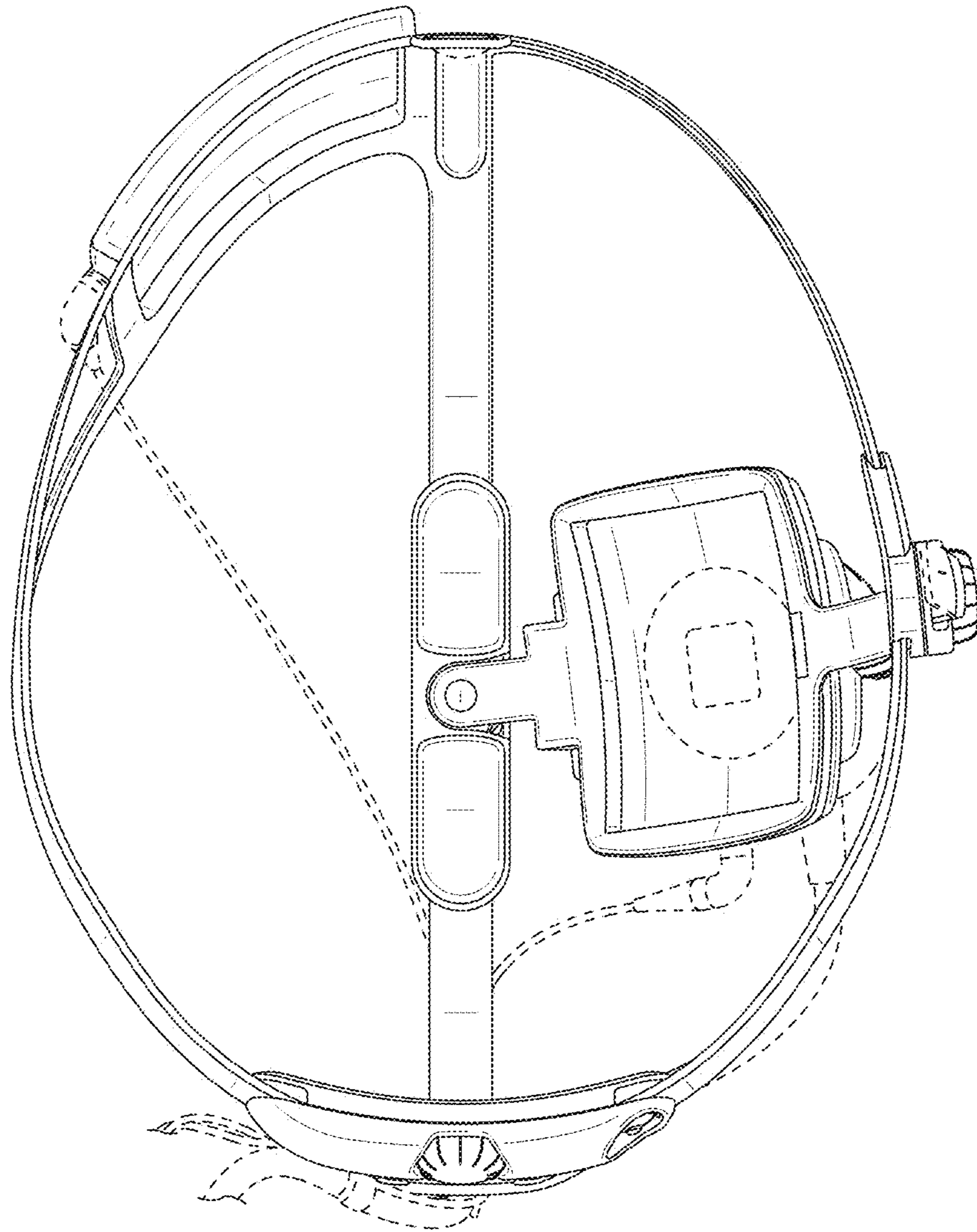

FIG.8