



US00D759728S

(12) **United States Design Patent**
Byrne et al.

(10) **Patent No.:** **US D759,728 S**
(45) **Date of Patent:** **** Jun. 21, 2016**

- (54) **POWER END FRAME SEGMENT**
- (71) Applicant: **S.P.M. Flow Control, Inc.**, Fort Worth, TX (US)
- (72) Inventors: **Joseph H. Byrne**, Hudson Oaks, TX (US); **Jacob A. Bayyouk**, Richardson, TX (US); **Chandu Kumar**, Fort Worth, TX (US)
- (73) Assignee: **S.P.M. Flow Control, Inc.**, Fort Worth, TX (US)
- (**) Term: **15 Years**
- (21) Appl. No.: **29/534,091**
- (22) Filed: **Jul. 24, 2015**

- 3,206,242 A 9/1965 Fensin
- 3,236,315 A 2/1966 Lora
- 3,358,352 A 12/1967 Wilcox
- 3,595,101 A 7/1971 Cooper, Sr.
- 3,760,694 A 9/1973 Lieb
- 3,883,941 A 5/1975 Coil

(Continued)

FOREIGN PATENT DOCUMENTS

EP 2397694 A1 12/2011

OTHER PUBLICATIONS

“Simatool Bearing Handling Tool BHT,” Simatec Smart Technologies; Dec. 19, 2013; <http://www.simatec.com/products/simatool/bearinghandlingtool/>.

(Continued)

Primary Examiner — Ralf Seifert

(74) *Attorney, Agent, or Firm* — Gardere Wynne Sewell LLP

Related U.S. Application Data

- (63) Continuation of application No. 14/808,513, filed on Jul. 24, 2015.
- (51) **LOC (10) Cl.** **15-02**
- (52) **U.S. Cl.**
USPC **D15/9**
- (58) **Field of Classification Search**
USPC D15/7-9; D23/231, 232, 225; 417/60, 417/235, 265, 321, 355, 358, 363, 359, 417/410.1, 415-416, 405, 900; 60/408, 60/412; 137/343, 565.34; 184/26-37; 415/140-147; 123/495, 509
CPC F02M 37/04; F02M 37/14
See application file for complete search history.

(57) **CLAIM**

The ornamental design for a power end frame segment, as shown and described.

DESCRIPTION

FIG. 1 is a front perspective view of a power end frame segment;
FIG. 2 is a front view of the power end frame segment;
FIG. 3 is a rear view of the power end frame segment;
FIG. 4 is left side view of the power end frame segment;
FIG. 5 is a right side view of the power end frame segment;
FIG. 6 is a top view of the power end frame segment; and,
FIG. 7 is a bottom view of the power end frame segment.
The broken lines in FIGS. 1 through 7 form no part of the claimed design.

(56) **References Cited**
U.S. PATENT DOCUMENTS

- 2,056,622 A 10/1936 Schaer
- 3,158,211 A 11/1964 McCue

1 Claim, 5 Drawing Sheets

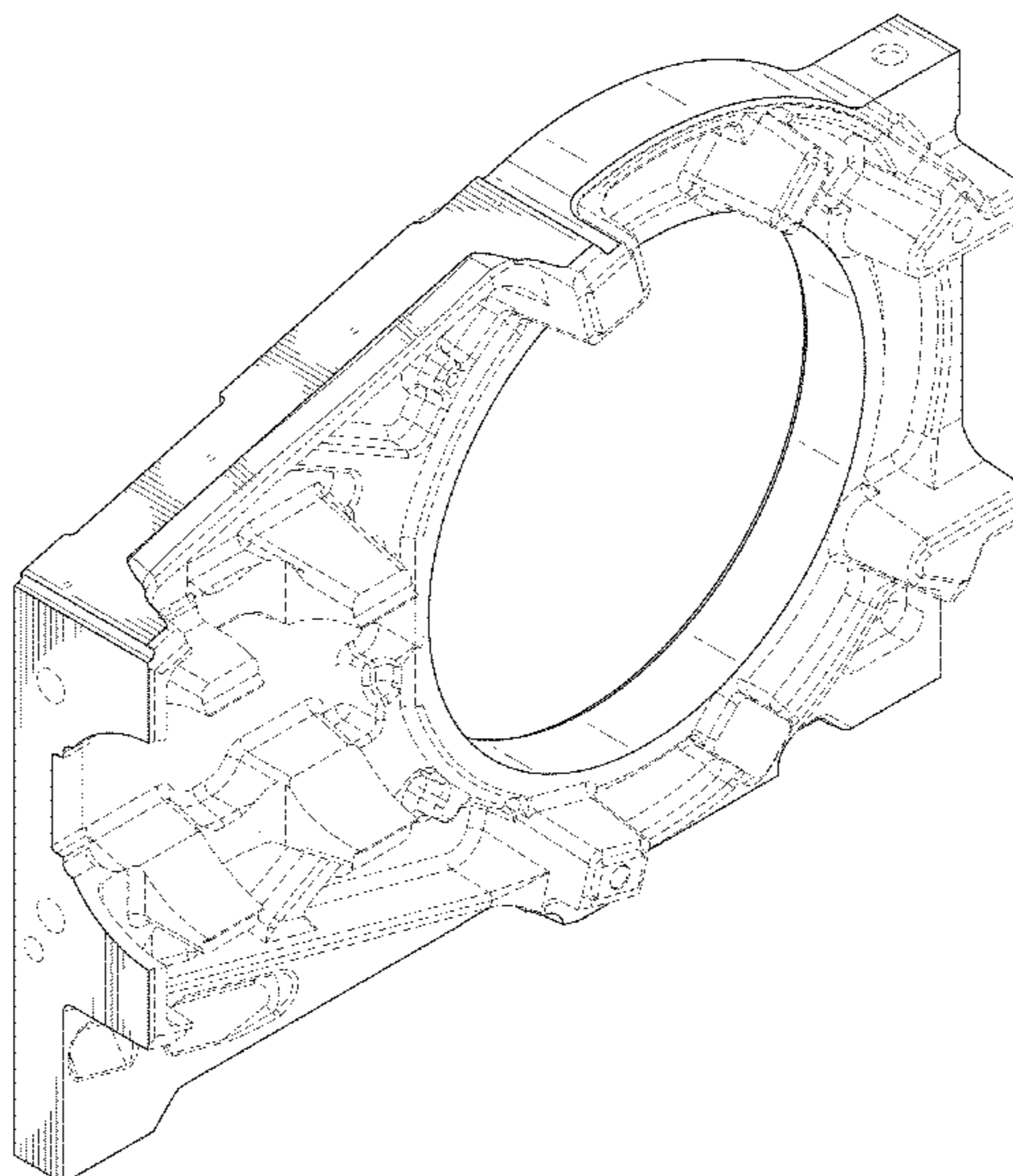

(56)

References Cited

U.S. PATENT DOCUMENTS

3,967,542 A 7/1976 Hall et al.
4,099,447 A 7/1978 Ogles
4,388,837 A 6/1983 Bender
4,477,237 A 10/1984 Grable
5,287,612 A 2/1994 Paddock et al.
D495,342 S * 8/2004 Tojo D15/7
D496,670 S * 9/2004 Ohnishi D15/7
D538,824 S * 3/2007 Tojo D15/7
D591,311 S * 4/2009 Tojo D15/7
D670,312 S * 11/2012 Alexander D15/7
D692,026 S * 10/2013 Alexander D15/7
8,707,853 B1 4/2014 Dille et al.

2008/0078583 A1 4/2008 Cummins
2009/0092510 A1 4/2009 Williams et al.
2010/0129249 A1 5/2010 Bianchi et al.
2014/0196570 A1 7/2014 Small et al.

OTHER PUBLICATIONS

International Search Report mailed Dec. 4, 2015 in corresponding PCT application PCT/US2015/042078, 13 pages.
International Search Report and Written Opinion mailed Dec. 28, 2015 in corresponding international application PCT/US2015/042043, 14 pages.
International Search Report mailed Jun. 29, 2015 in corresponding PCT application, PCT/US2015/014898, 14 pages.

* cited by examiner

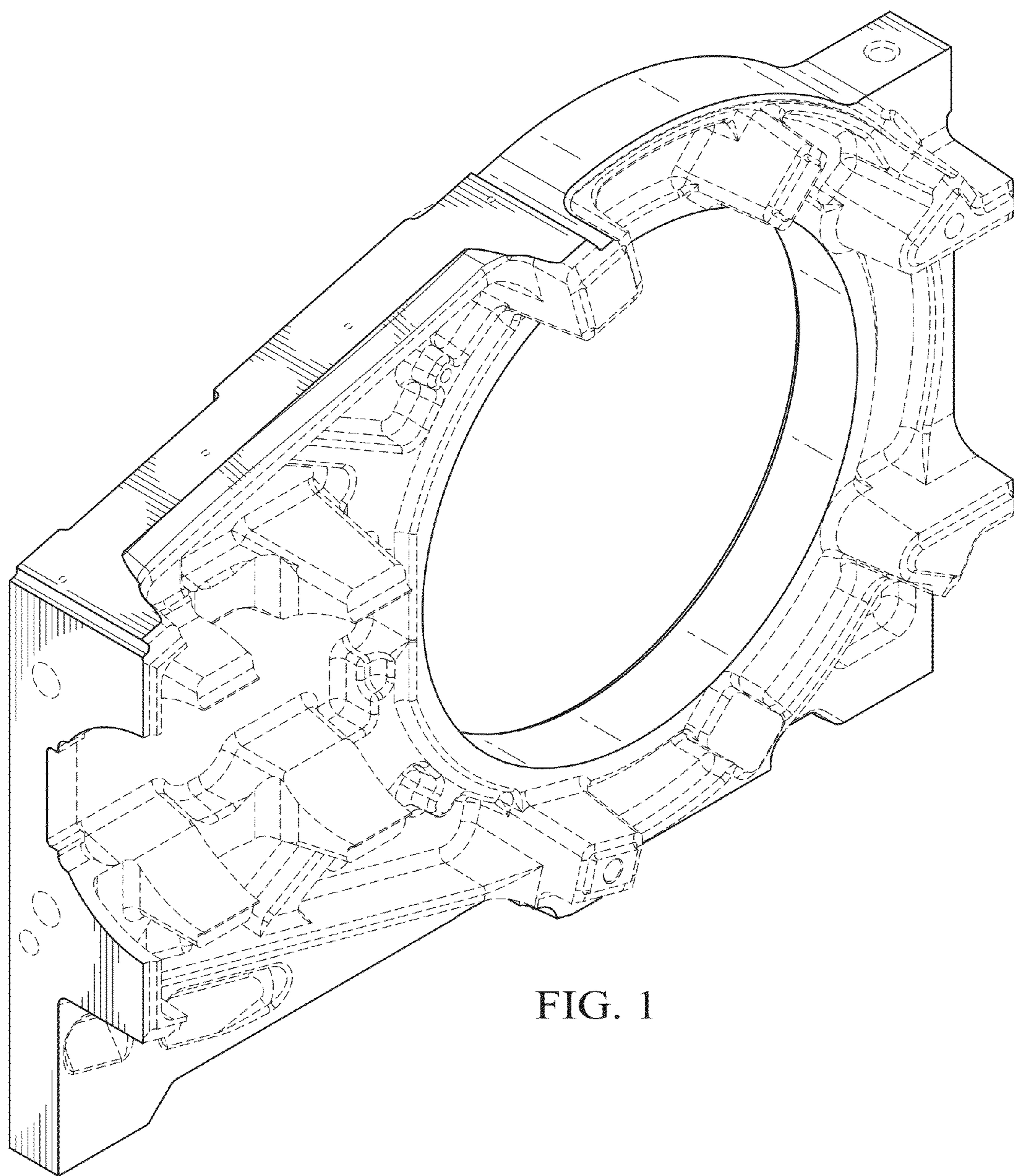

FIG. 1

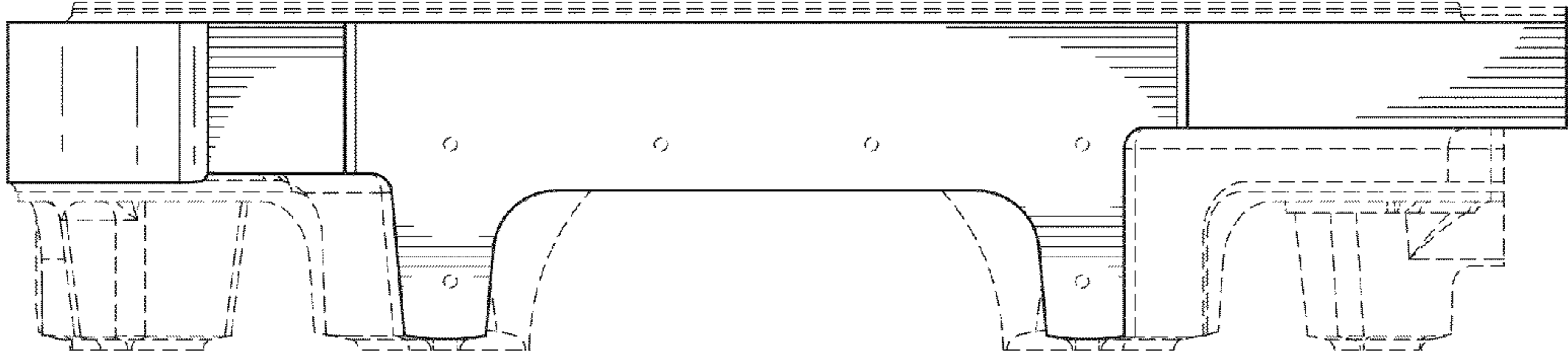

FIG. 3

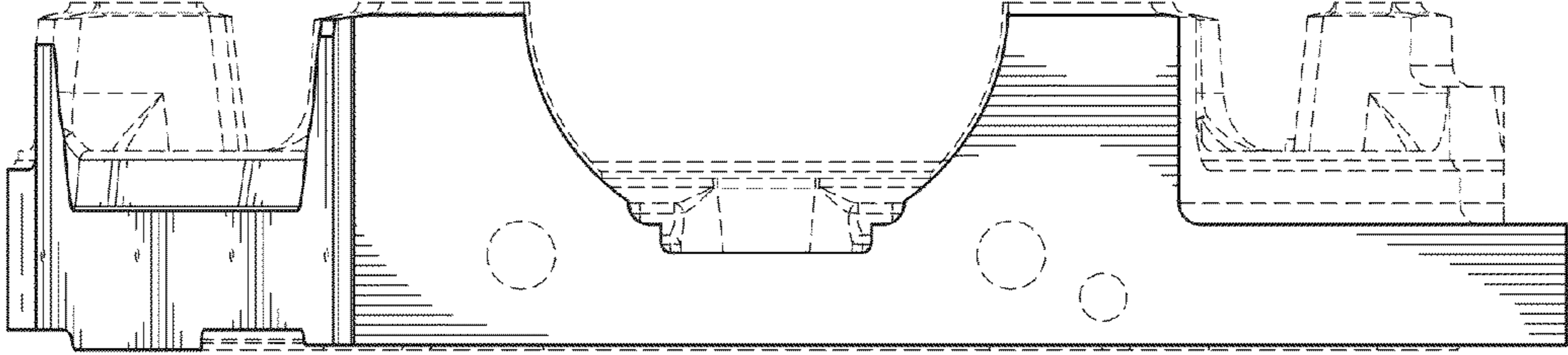

FIG. 2

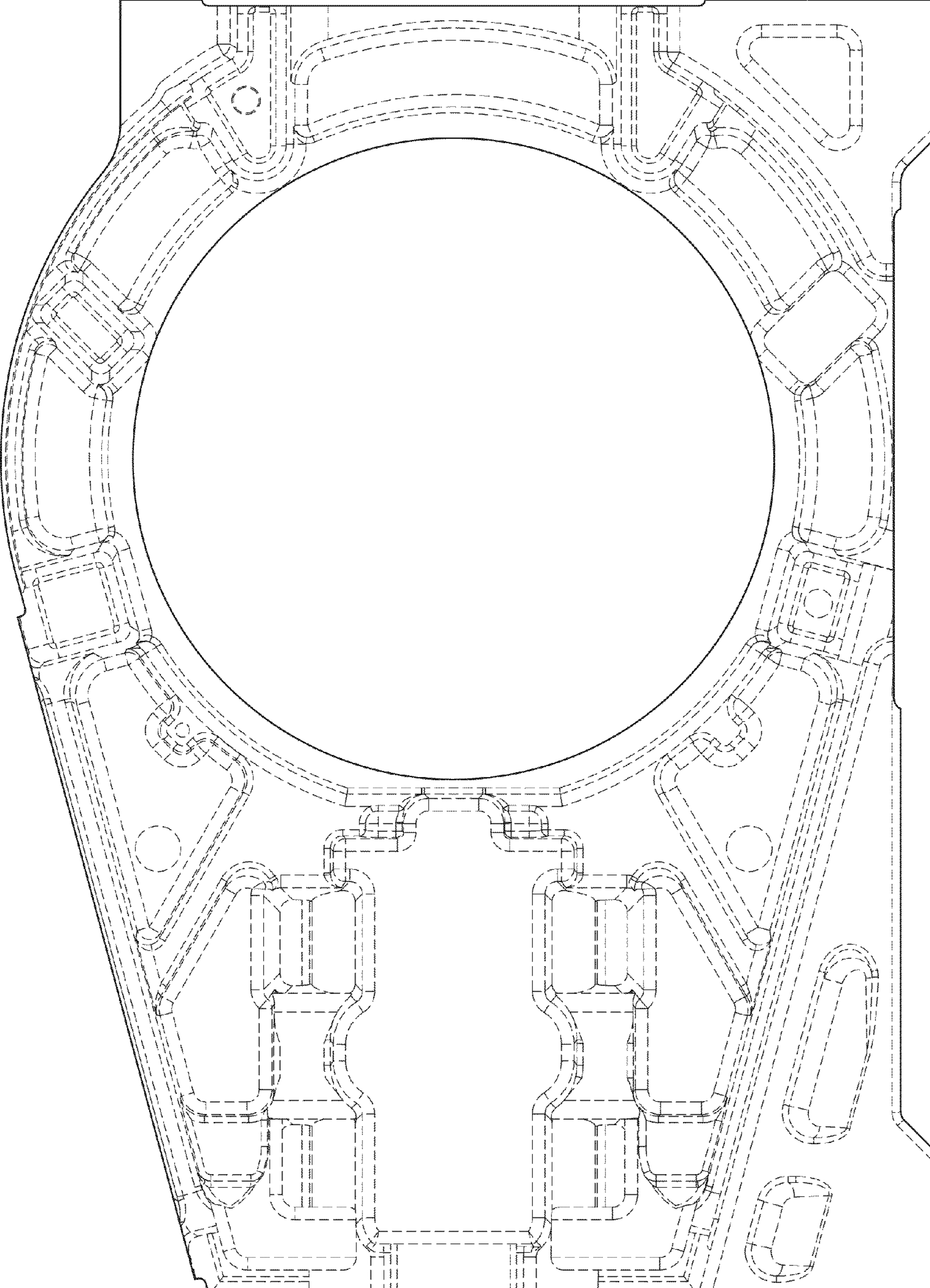

FIG. 4

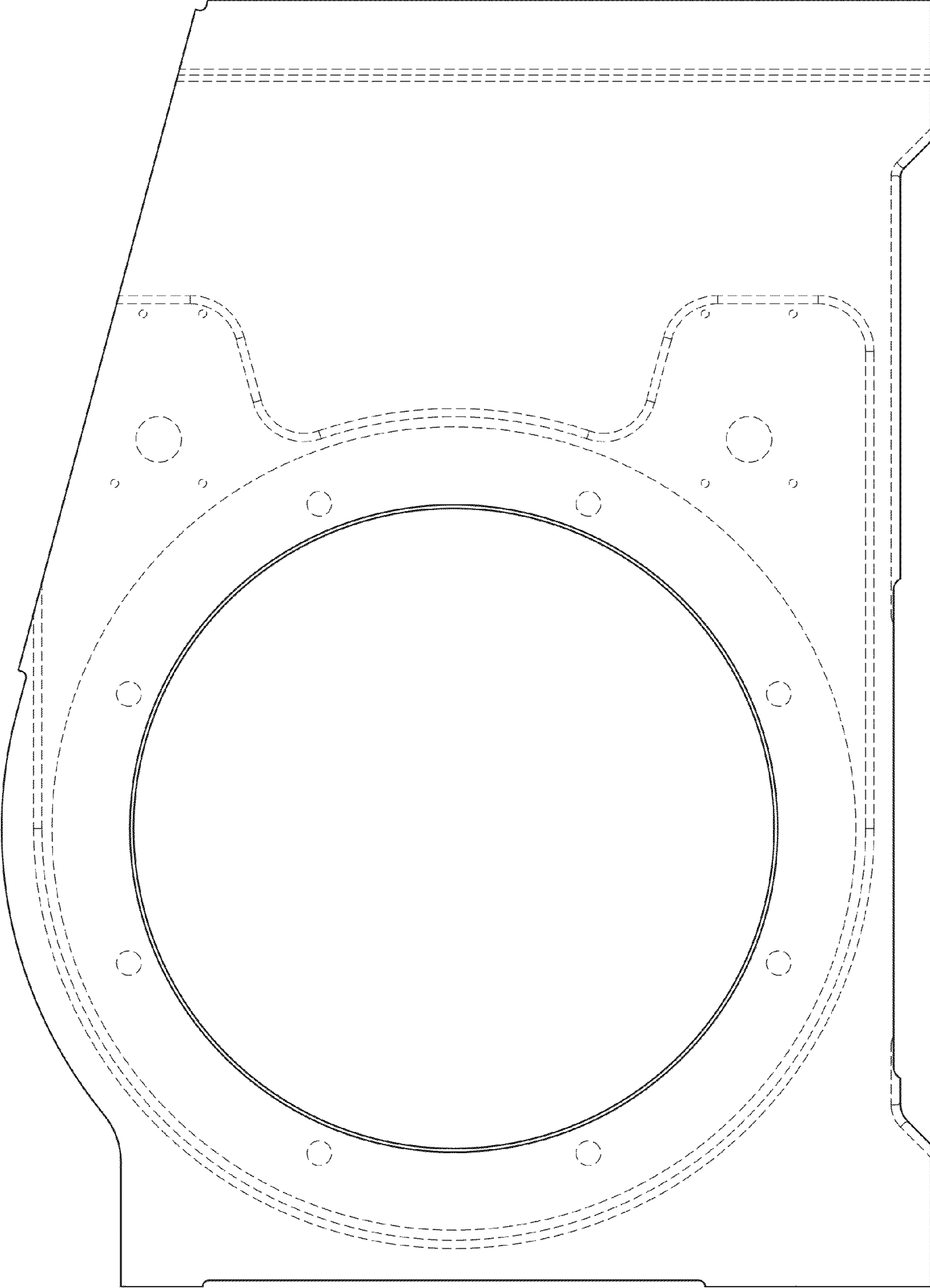

FIG. 5

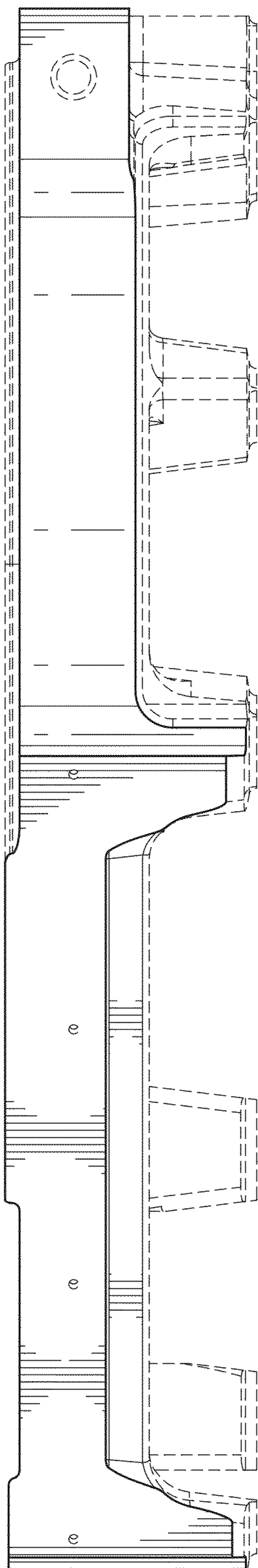

FIG. 6

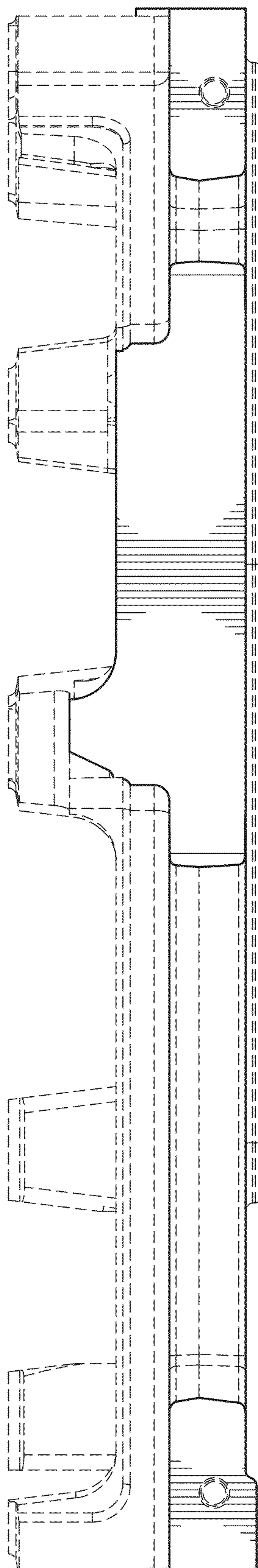

FIG. 7