



US00D759122S

(12) **United States Design Patent**
Verdu

(10) **Patent No.:** **US D759,122 S**
(45) **Date of Patent:** **** Jun. 14, 2016**

(54) **MUSIC PLAYER**
(71) Applicant: **UBITHINGS**, Puteaux (FR)
(72) Inventor: **Pierre Verdu**, Triel sur Seine (FR)
(73) Assignee: **UBITHINGS**, Puteaux (FR)
(**) Term: **14 Years**
(21) Appl. No.: **29/520,753**
(22) Filed: **Mar. 17, 2015**

6,324,292 B1 * 11/2001 Mitsuhashi H04R 1/288
181/151
D503,395 S * 3/2005 Hirano D14/168
6,897,368 B2 * 5/2005 Georges G10H 1/0025
84/609
D509,223 S * 9/2005 Steele D14/168
D556,737 S * 12/2007 Oh D14/168
D599,761 S * 9/2009 Birsel D14/138 AB
D599,821 S * 9/2009 Tang D14/168
D619,116 S * 7/2010 Skurdal D10/2
D651,618 S * 1/2012 Barley D14/496
D692,460 S * 10/2013 Zunker D14/496
D718,750 S * 12/2014 Young D14/203.7
D730,942 S * 6/2015 Wong D14/203.1

* cited by examiner

(30) **Foreign Application Priority Data**
Sep. 17, 2014 (FR) 2014-4112
(51) **LOC (10) Cl.** **14-03**
(52) **U.S. Cl.**
USPC **D14/496**; D14/168
(58) **Field of Classification Search**
USPC D14/496, 401, 435, 474, 483, 217, 137,
D14/138, 160, 168, 356, 203.1–203.8, 507;
345/156, 169, 173–179, 905;
715/727–729, 864; 710/1, 5, 8; 713/1,
713/600; 455/1.1, 1.7, 73, 344–347, 93, 95,
455/3.01–3.06, 550.1, 573.1; 370/342–344;
369/1, 2, 6–12; 463/43–47; 273/148 B
CPC A63F 9/24; A63F 13/00; G06F 9/24;
G06F 12/00; G06F 19/00; H05K 5/00
See application file for complete search history.

Primary Examiner — Prabhakar Deshmukh
(74) *Attorney, Agent, or Firm* — Young & Thompson

(56) **References Cited**
U.S. PATENT DOCUMENTS
3,198,339 A * 8/1965 Stolarz B42D 5/043
211/50

(57) **CLAIM**
The ornamental design for a music player, as shown and described.

DESCRIPTION
FIG. 1 is a front elevation view of a music player showing the new design;
FIG. 2 is a rear elevation view thereof; and,
FIG. 3 is a top plan view thereof.
The broken lines indicate unclaimed portions and form no part of the claimed design.

1 Claim, 1 Drawing Sheet

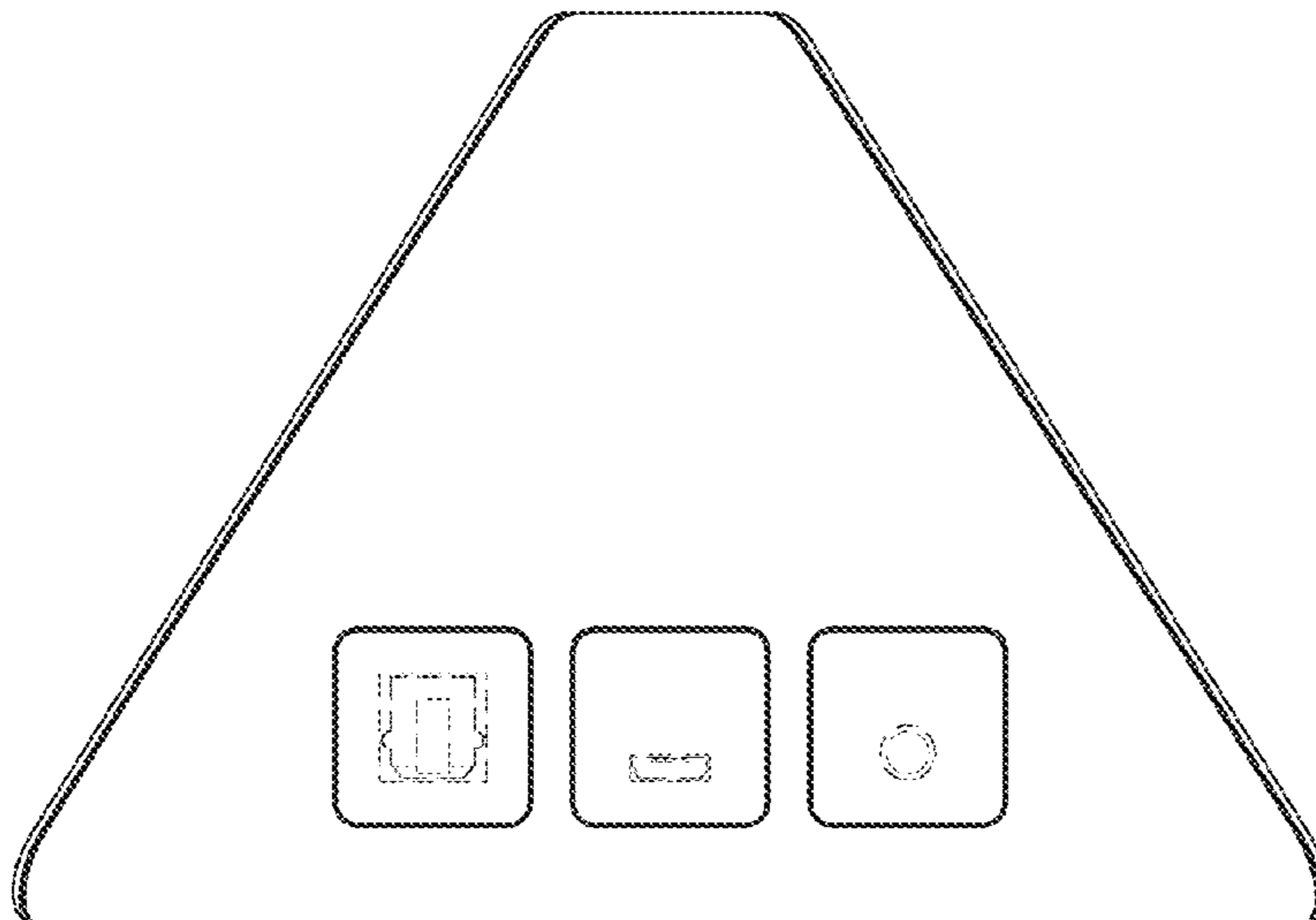

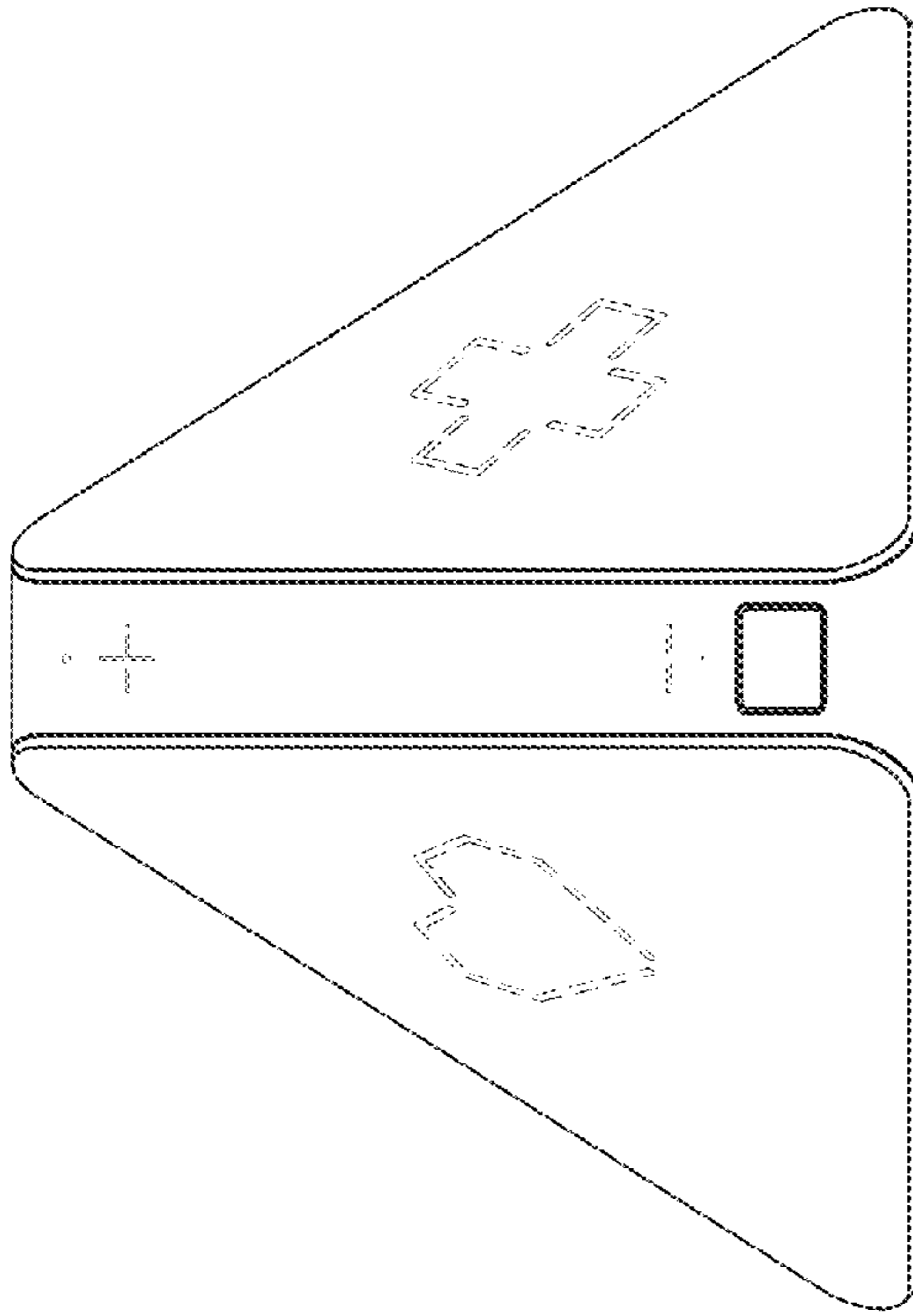

Fig. 1

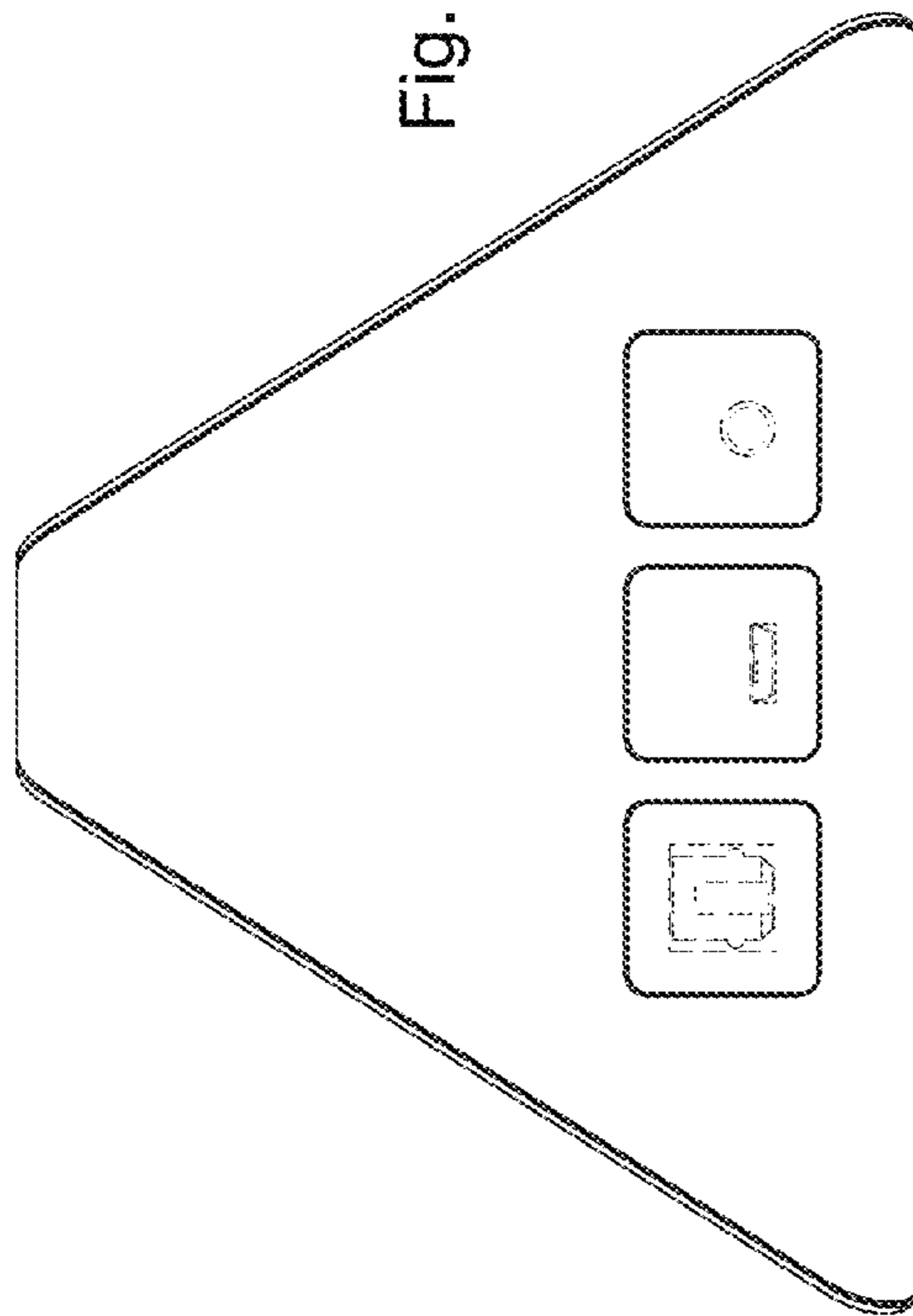

Fig. 2

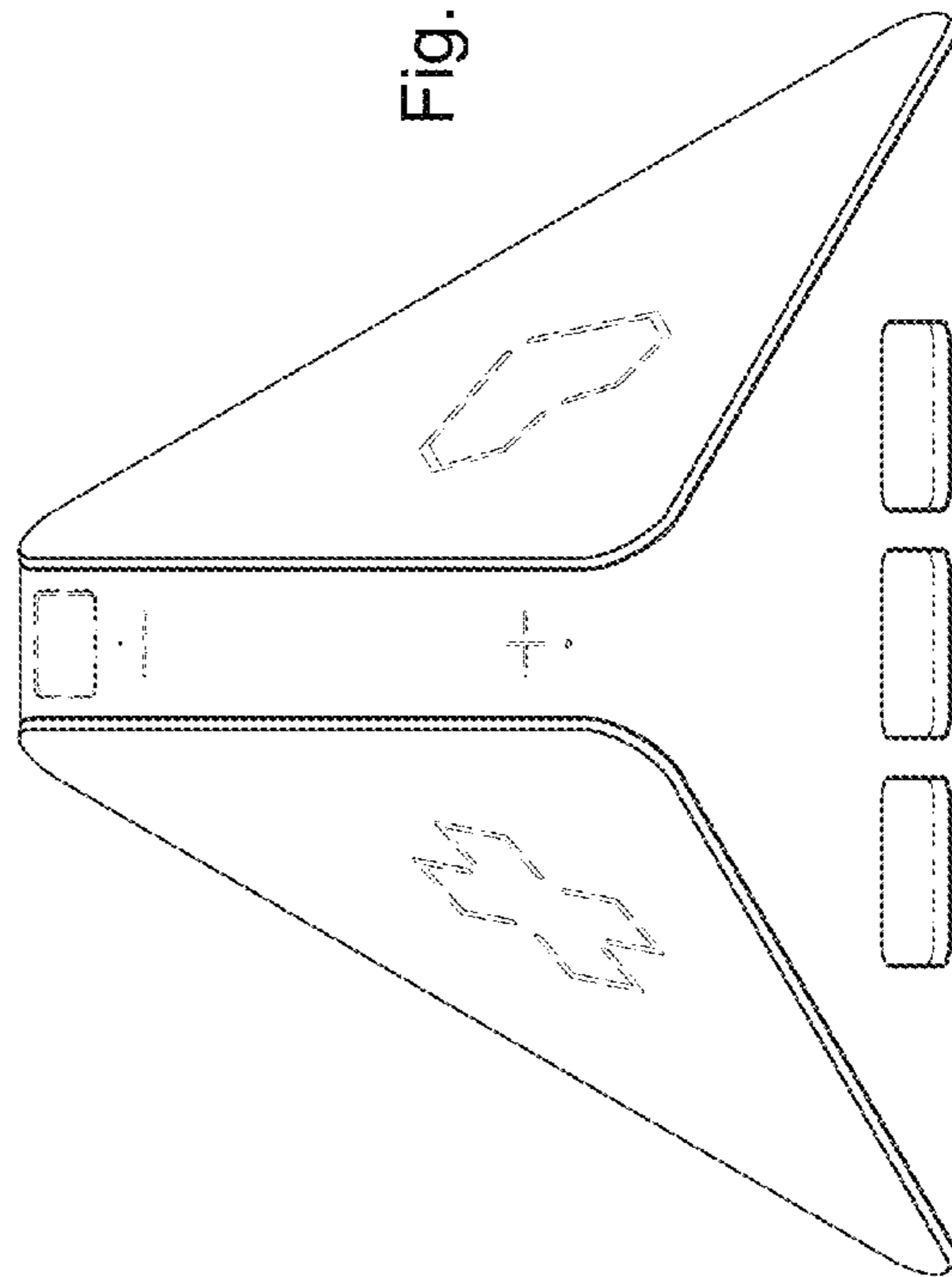

Fig. 3