



US00D758688S

(12) **United States Design Patent**
Nai

(10) **Patent No.:** **US D758,688 S**
(45) **Date of Patent:** **** Jun. 7, 2016**

- (54) **CART**
- (71) Applicant: **JPJ Investment Holding Corp.**, City of Industry, CA (US)
- (72) Inventor: **Guang Jun Nai**, Shanghai (CN)
- (73) Assignee: **JPJ INVESTMENT HOLDING CORP.**, City of Industry, CA (US)

7,857,329 B2	12/2010	Cai	
8,267,261 B2	9/2012	Vanderhoek et al.	
8,505,960 B1 *	8/2013	Shindelar	B62B 1/00 280/47.34
2006/0232032 A1	10/2006	Goldberg	
2013/0033014 A1 *	2/2013	Yang	B62B 3/02 280/47.35

(**) Term: **14 Years**

* cited by examiner

Primary Examiner — Cynthia Ramirez

(21) Appl. No.: **29/517,037**

(74) *Attorney, Agent, or Firm* — Patterson & Sheridan, L.L.P.

(22) Filed: **Feb. 9, 2015**

(57) **CLAIM**
The ornamental design for a cart, as shown and described.

(51) **LOC (10) Cl.** **12-02**

DESCRIPTION

(52) **U.S. Cl.**

USPC **D34/12**

(58) **Field of Classification Search**

USPC D34/12-27; 280/47.35, 47.34, 33.991, 280/33.992, 79.2, 79.3

CPC B62B 2202/404; B62B 2202/406; B62B 1/262; B62B 1/264; B62B 1/14; B62B 3/02; B62B 3/10; B62B 3/12; B62B 3/006; B62B 3/002

See application file for complete search history.

FIG. 1 is a top front perspective view of a cart in a first position showing my new design;
 FIG. 2 is a top rear perspective view thereof;
 FIG. 3 is a bottom front perspective view thereof;
 FIG. 4 is bottom rear perspective view thereof;
 FIG. 5 is a front elevational view thereof;
 FIG. 6 is a right side elevational view thereof;
 FIG. 7 is a rear elevational view thereof;
 FIG. 8 is a left side elevational view thereof;
 FIG. 9 is a top plan view thereof;
 FIG. 10 is a bottom plan view thereof;
 FIG. 11 is a top front perspective view of the cart in a second position;
 FIG. 12 is a top rear perspective view thereof;
 FIG. 13 is a bottom front perspective view thereof;
 FIG. 14 is bottom rear perspective view thereof;
 FIG. 15 is a front elevational view thereof;
 FIG. 16 is a right side elevational view thereof;
 FIG. 17 is a rear elevational view thereof;
 FIG. 18 is a left side elevational view thereof;
 FIG. 19 is a top plan view thereof; and,
 FIG. 20 is a bottom plan view thereof.

(56) **References Cited**

U.S. PATENT DOCUMENTS

4,595,107 A	6/1986	Welsch	
4,644,876 A *	2/1987	Thomas	A47B 13/066 108/154
4,740,010 A *	4/1988	Moskovitz	A47N 31/04 108/170
D301,790 S	6/1989	Ivano	
4,998,023 A	3/1991	Kitts	
D354,382 S *	1/1995	Mogensen	D34/17
D381,168 S	7/1997	Delmerico et al.	
5,738,365 A *	4/1998	McCarthy	B62B 3/022 280/651
5,839,739 A	11/1998	Shannon et al.	
D445,229 S *	7/2001	Stravitz	D34/12
6,796,565 B2	9/2004	Choi et al.	
D555,871 S *	11/2007	Pong	D34/17
D608,969 S *	1/2010	Wise	D34/12

The broken lines shown in the figures are included for the purpose of illustrating environment and forms no part of the claimed design.

1 Claim, 18 Drawing Sheets

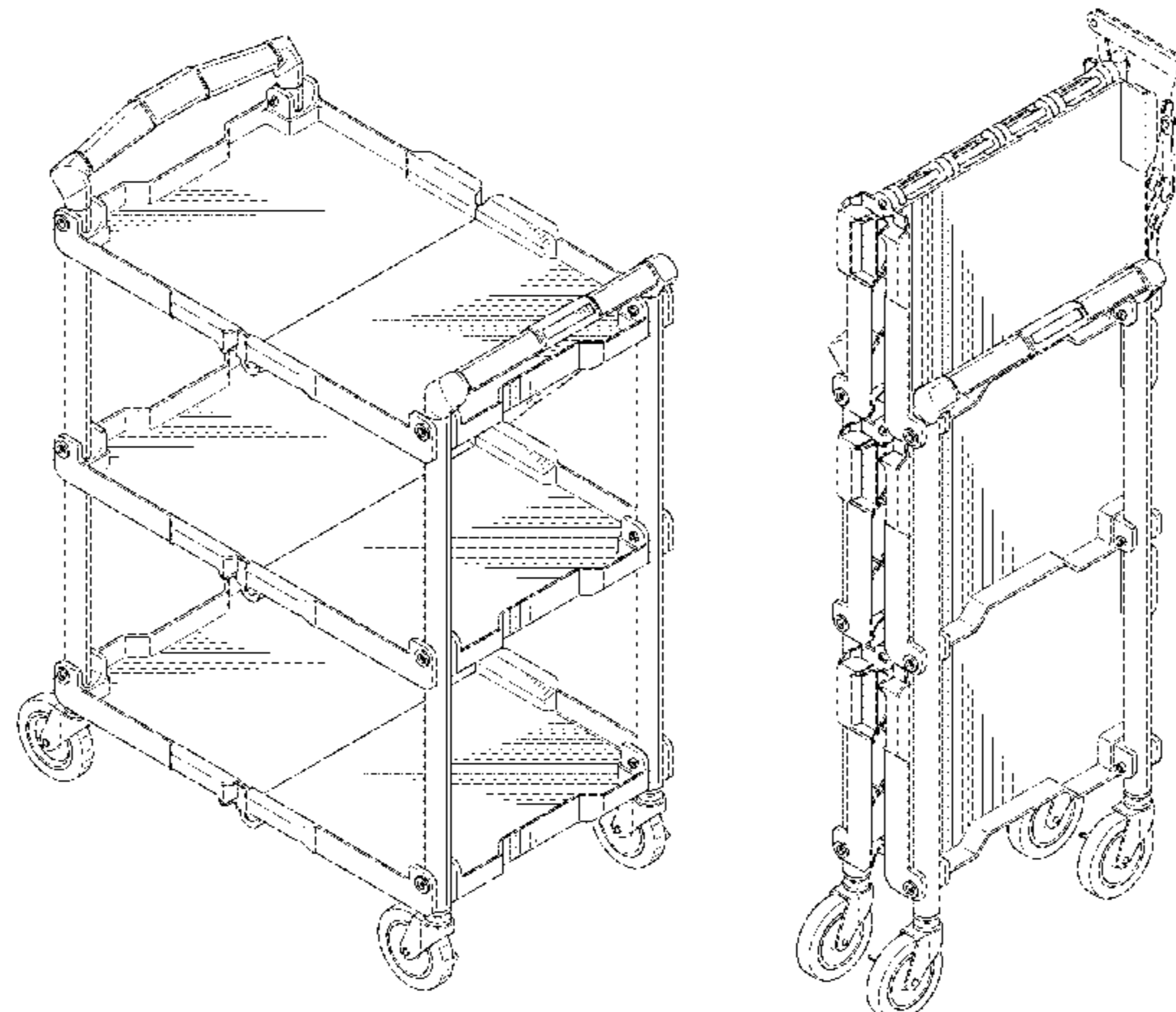

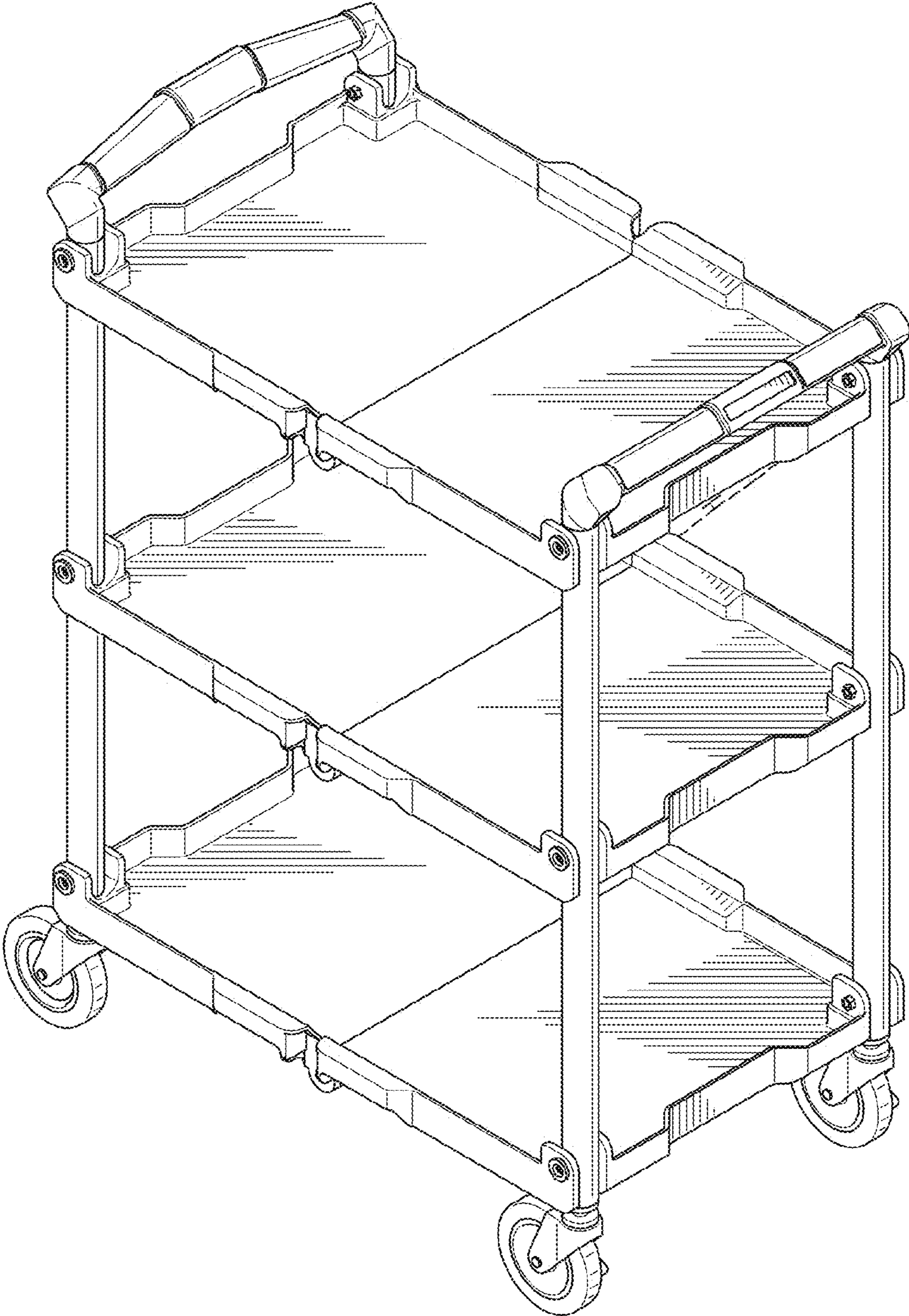

Fig. 1

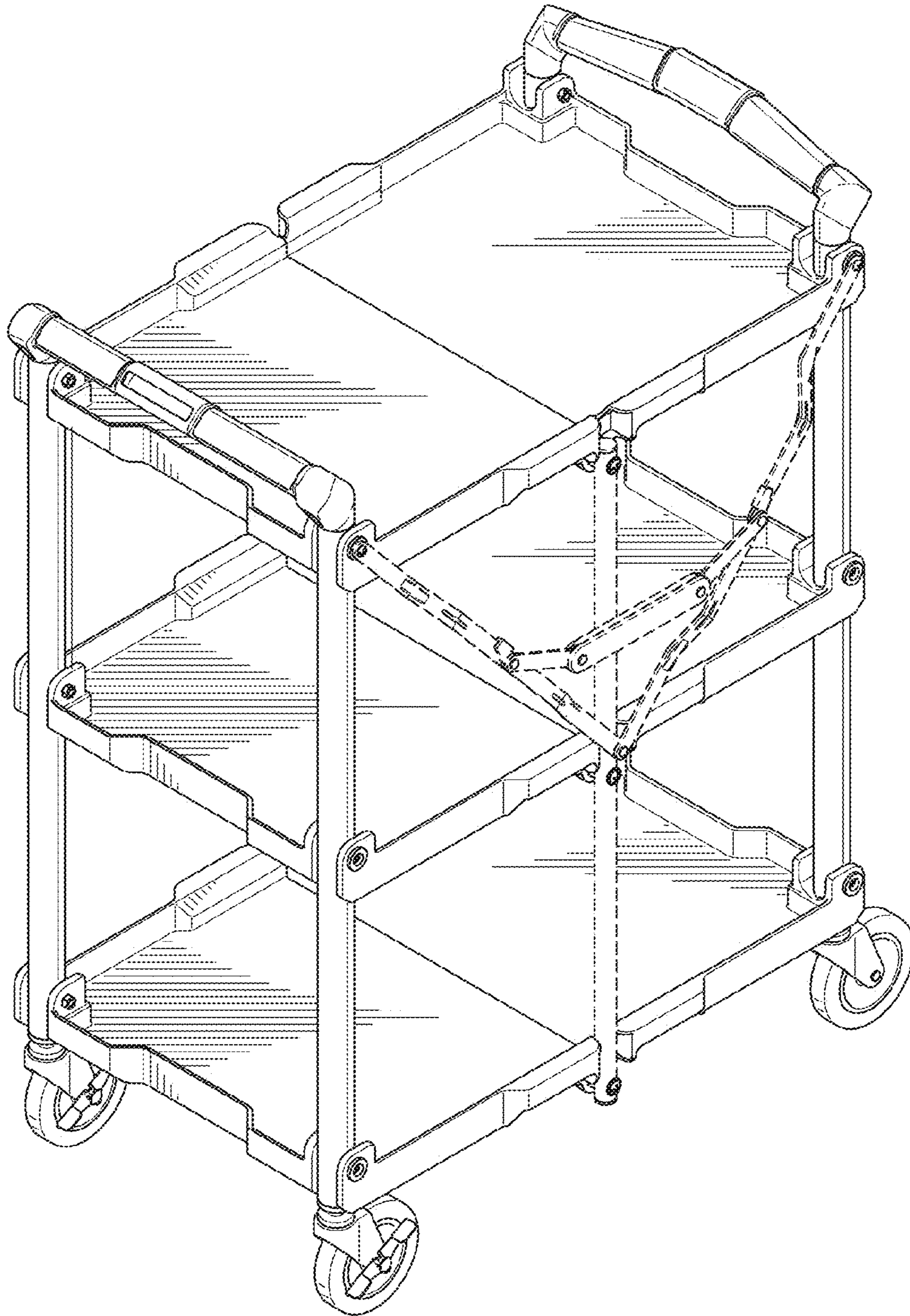

Fig. 2

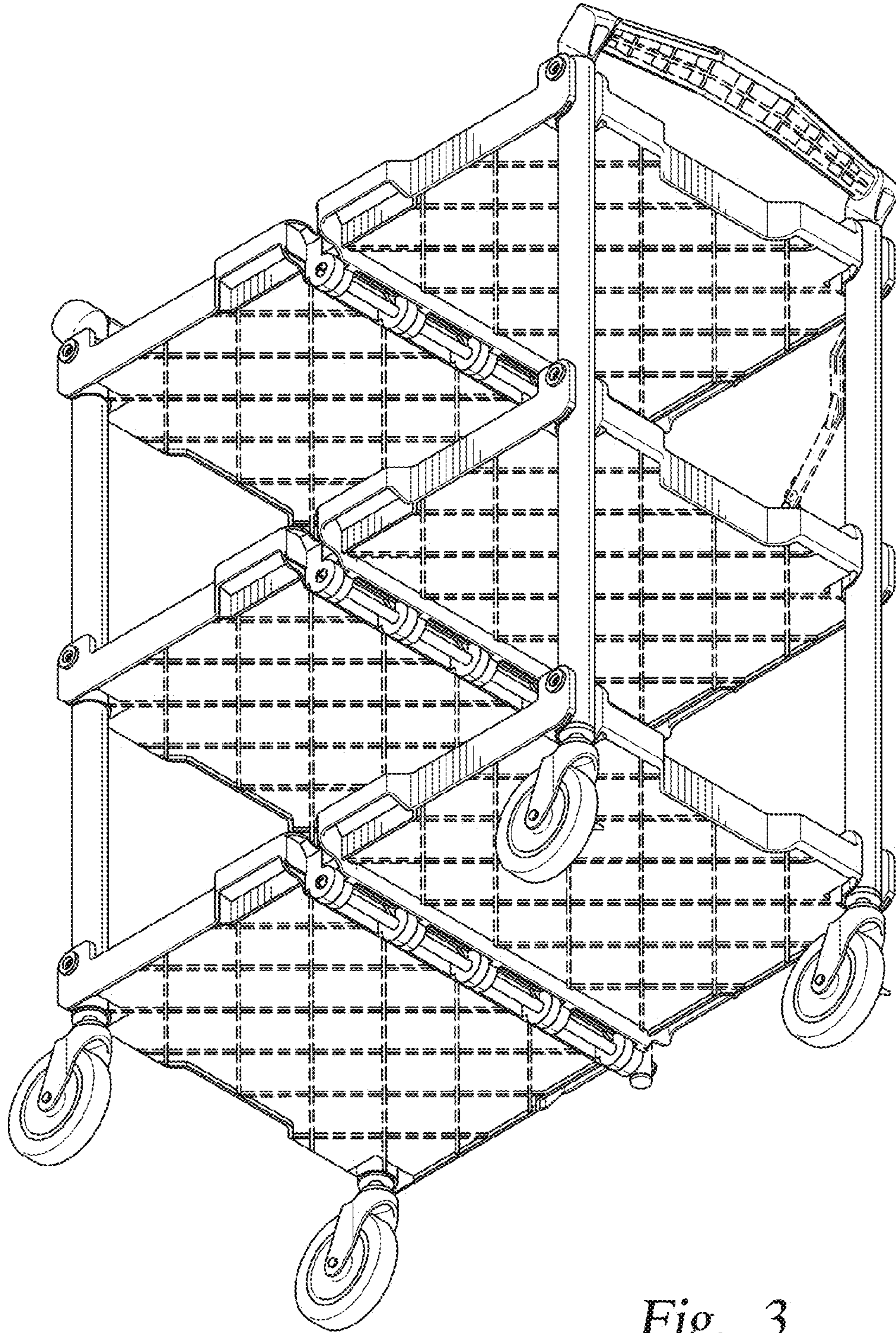

Fig. 3

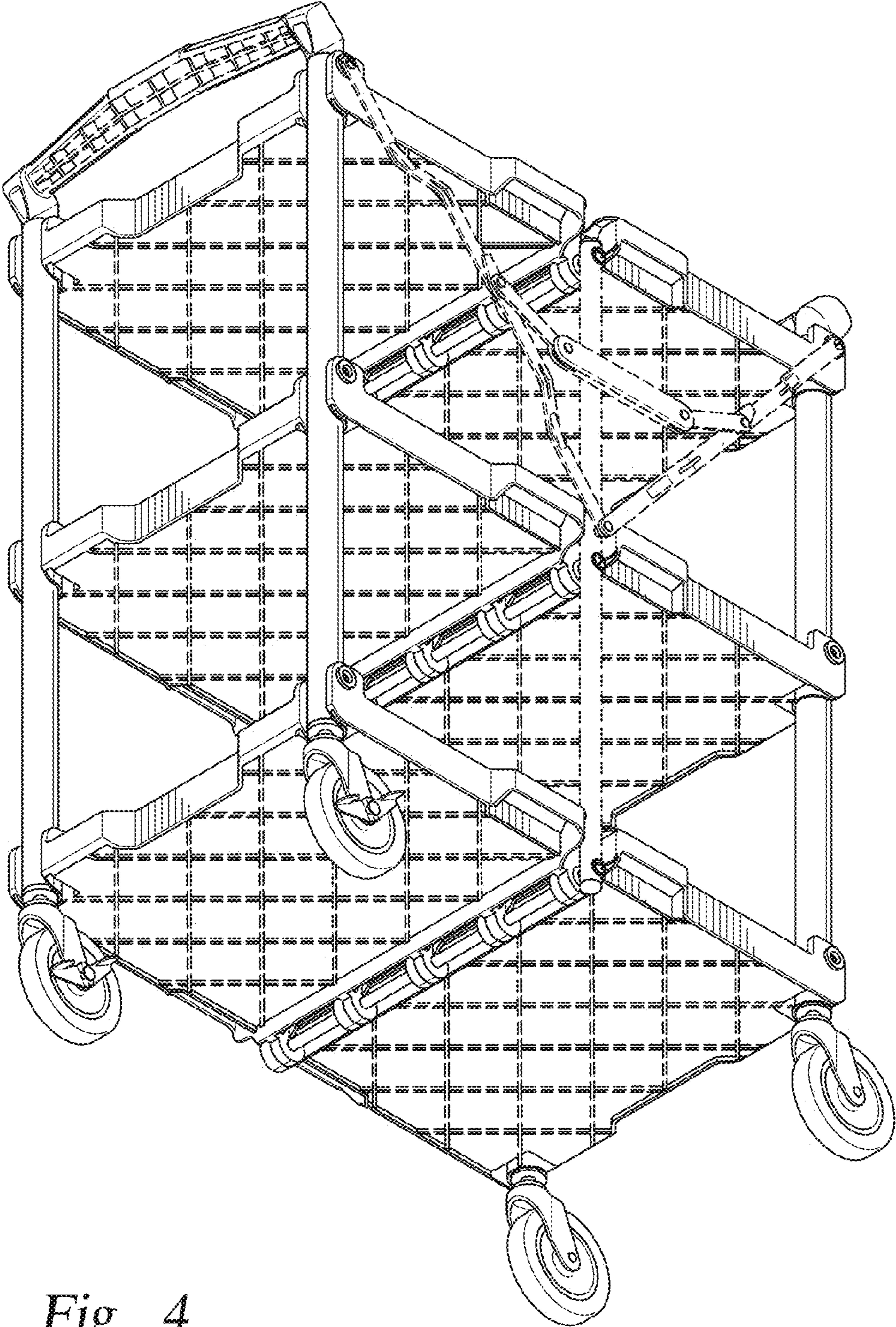

Fig. 4

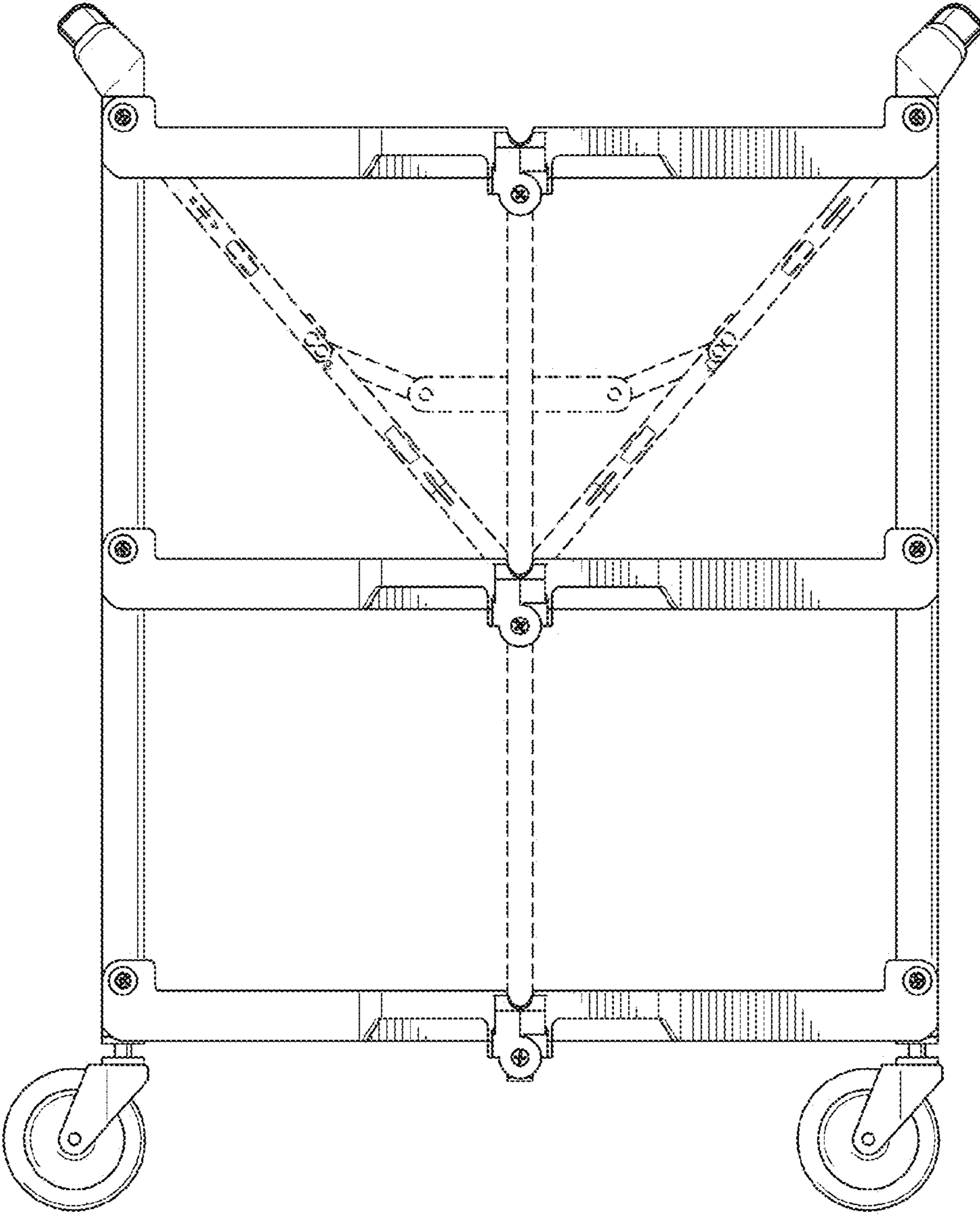

Fig. 5

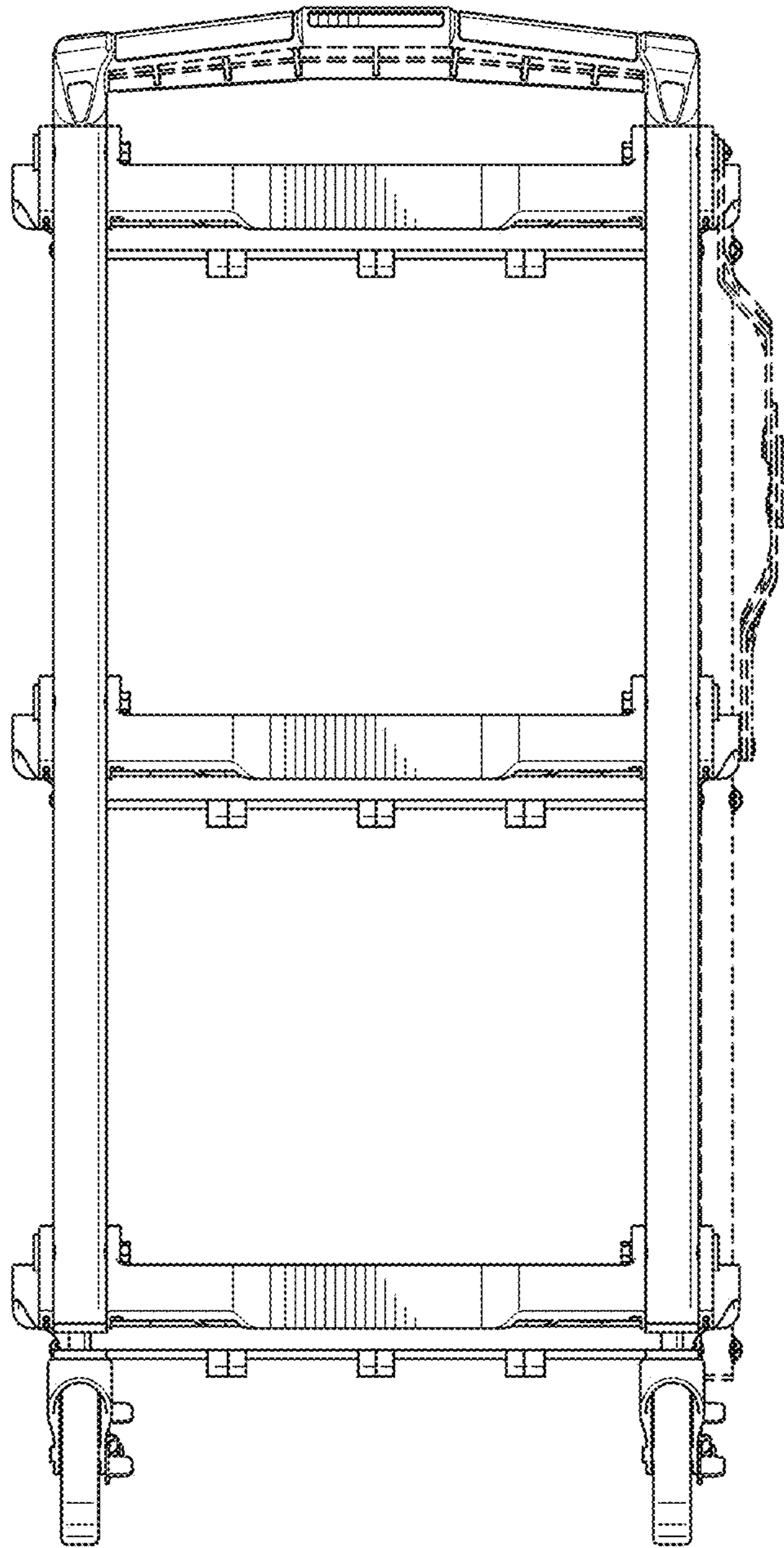

Fig. 6

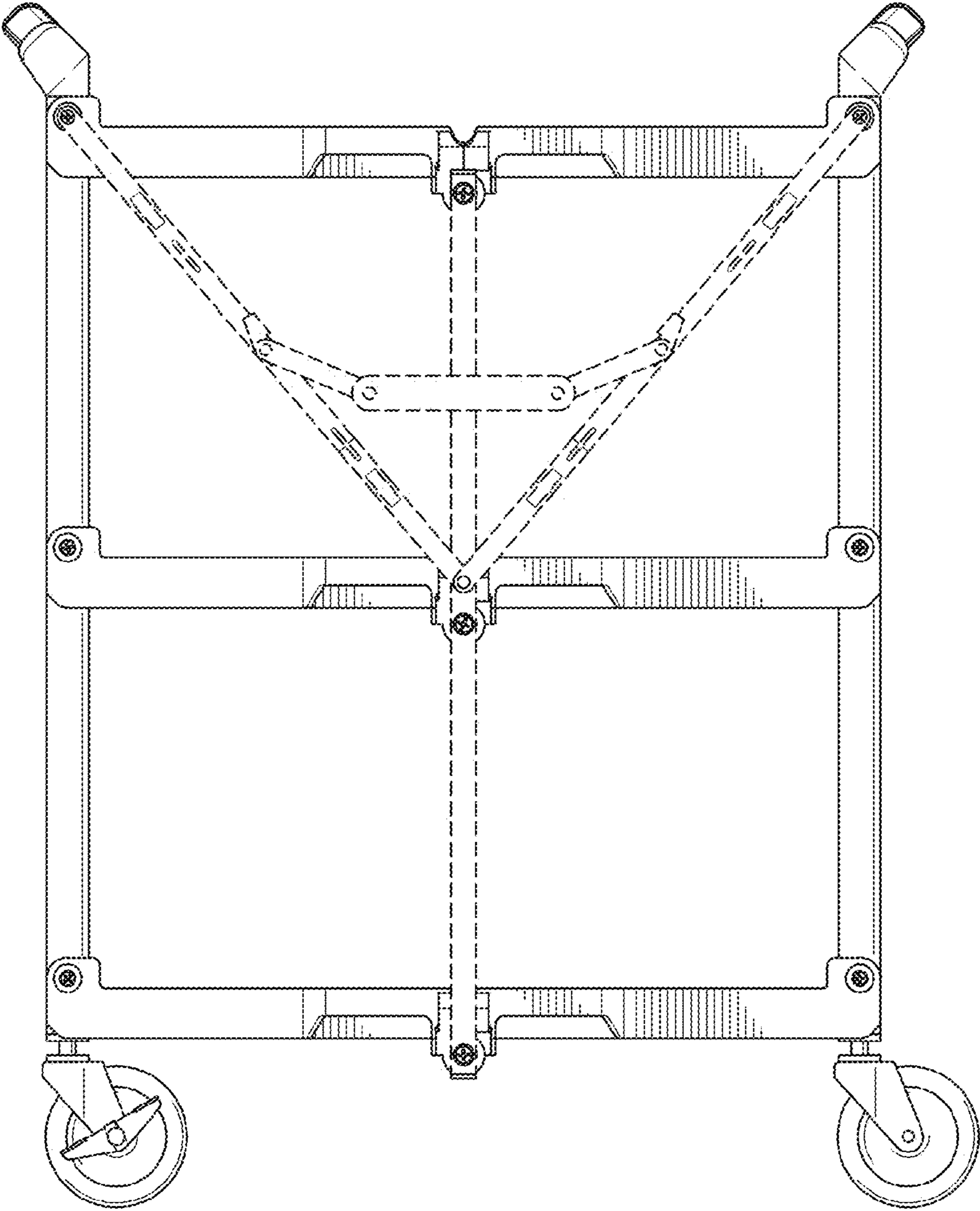

Fig. 7

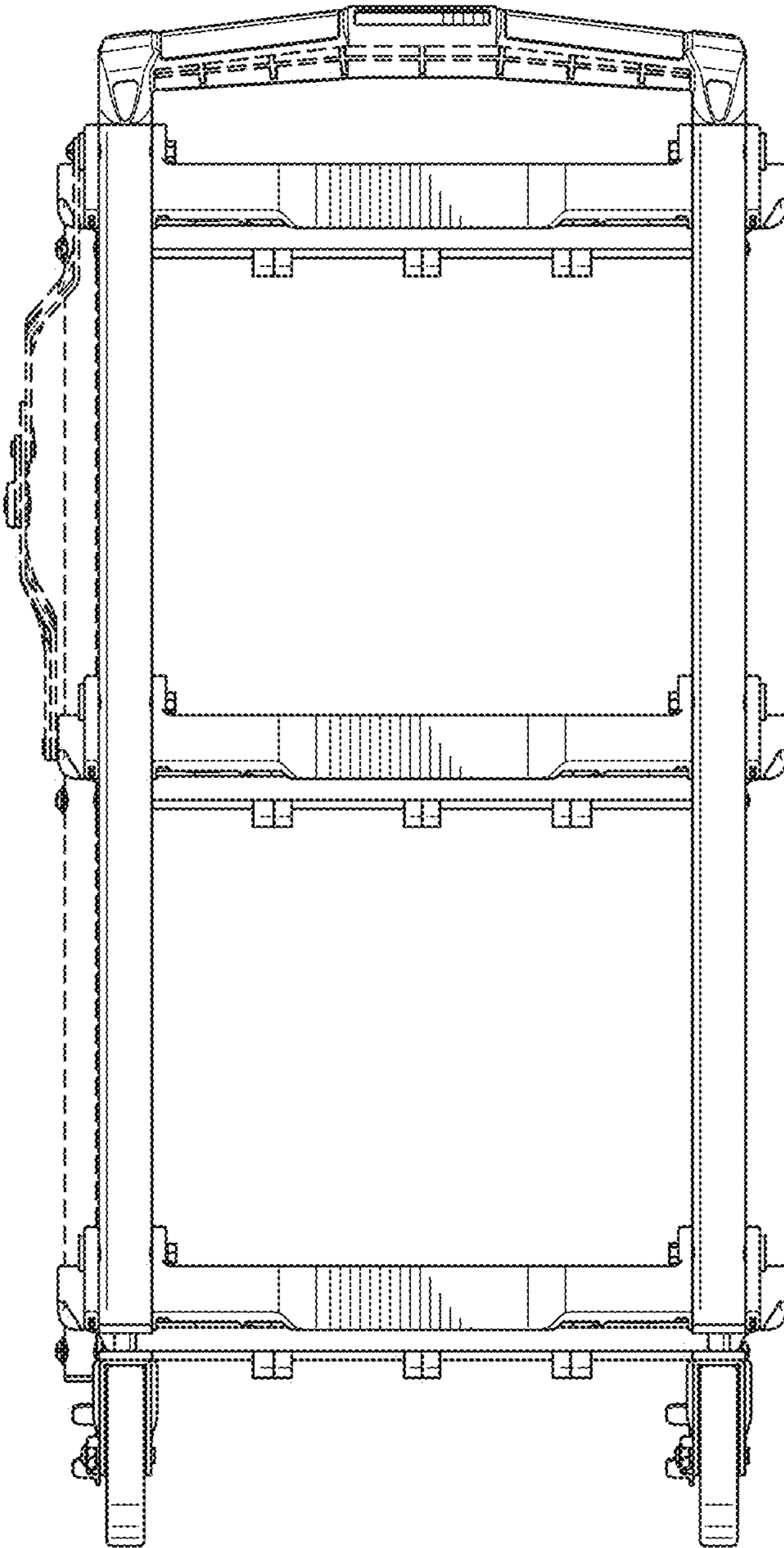

Fig. 8

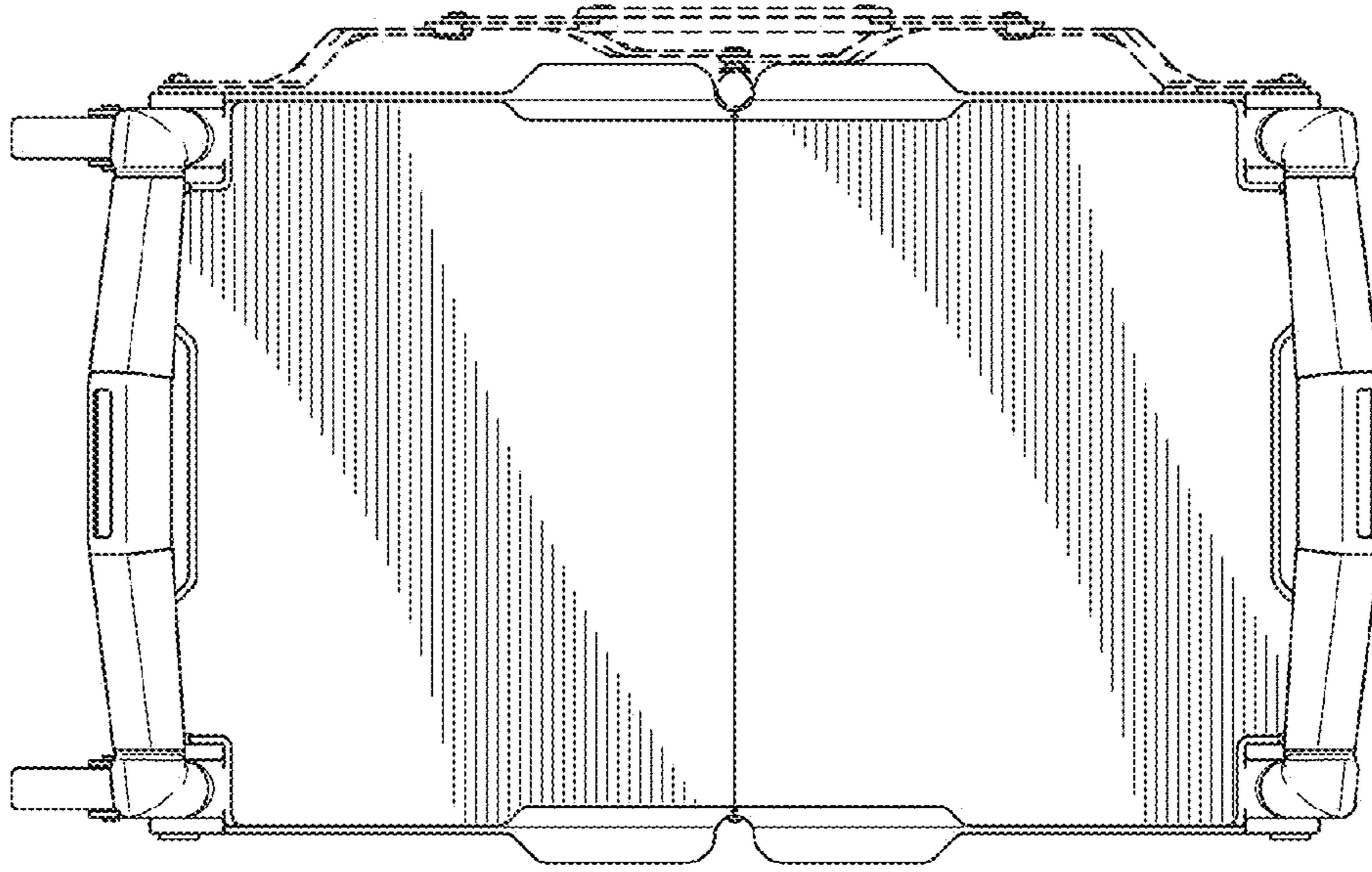

Fig. 9

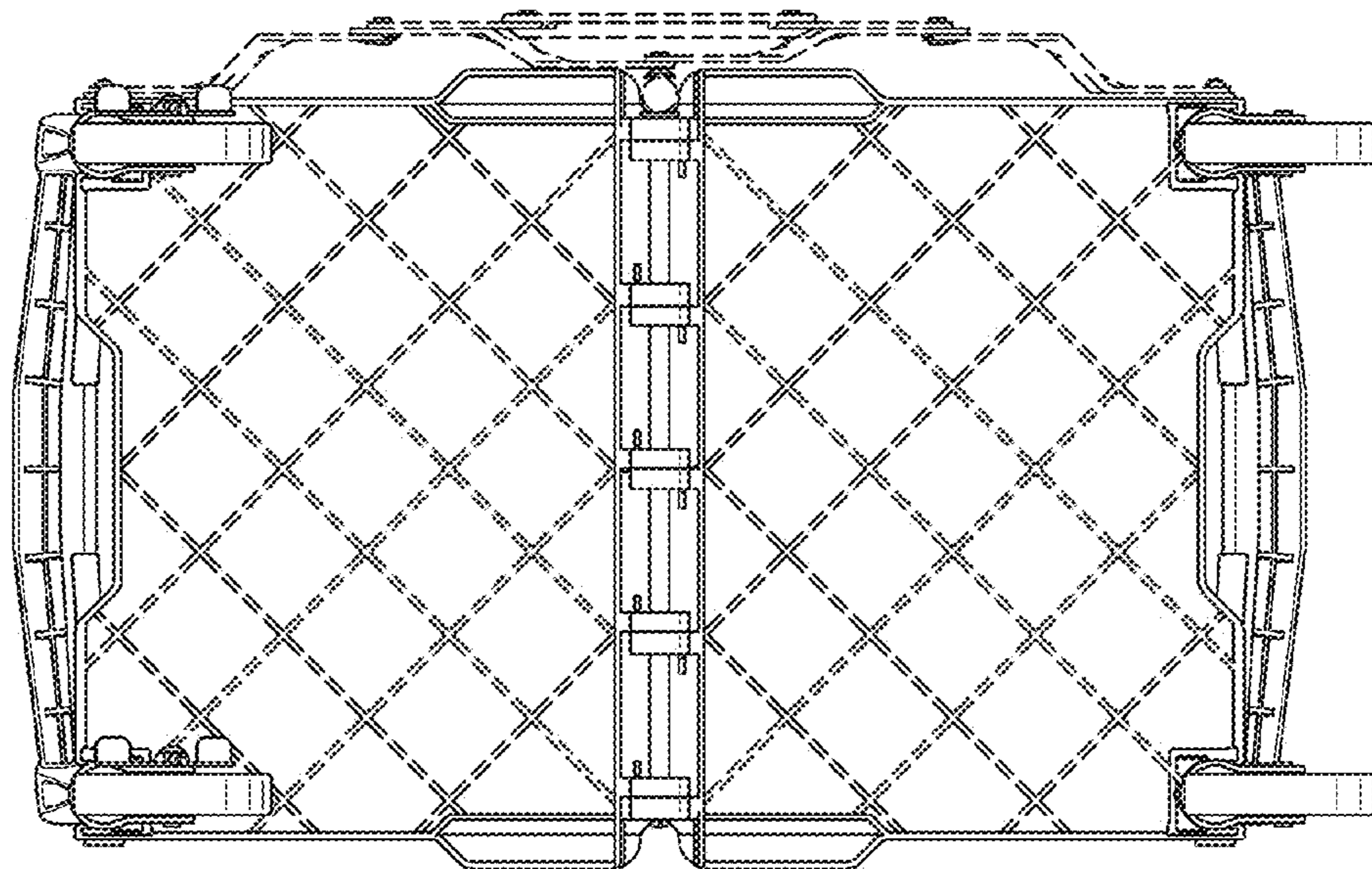

Fig. 10

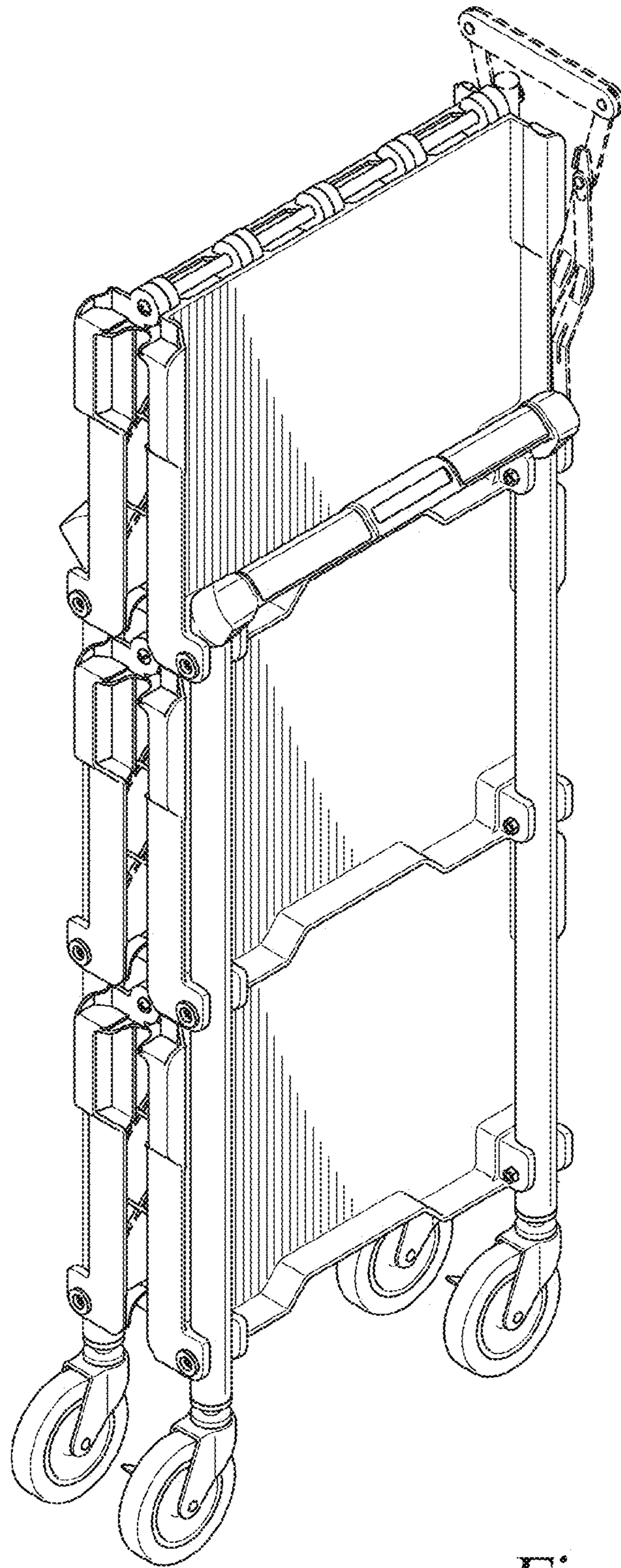

Fig. 11

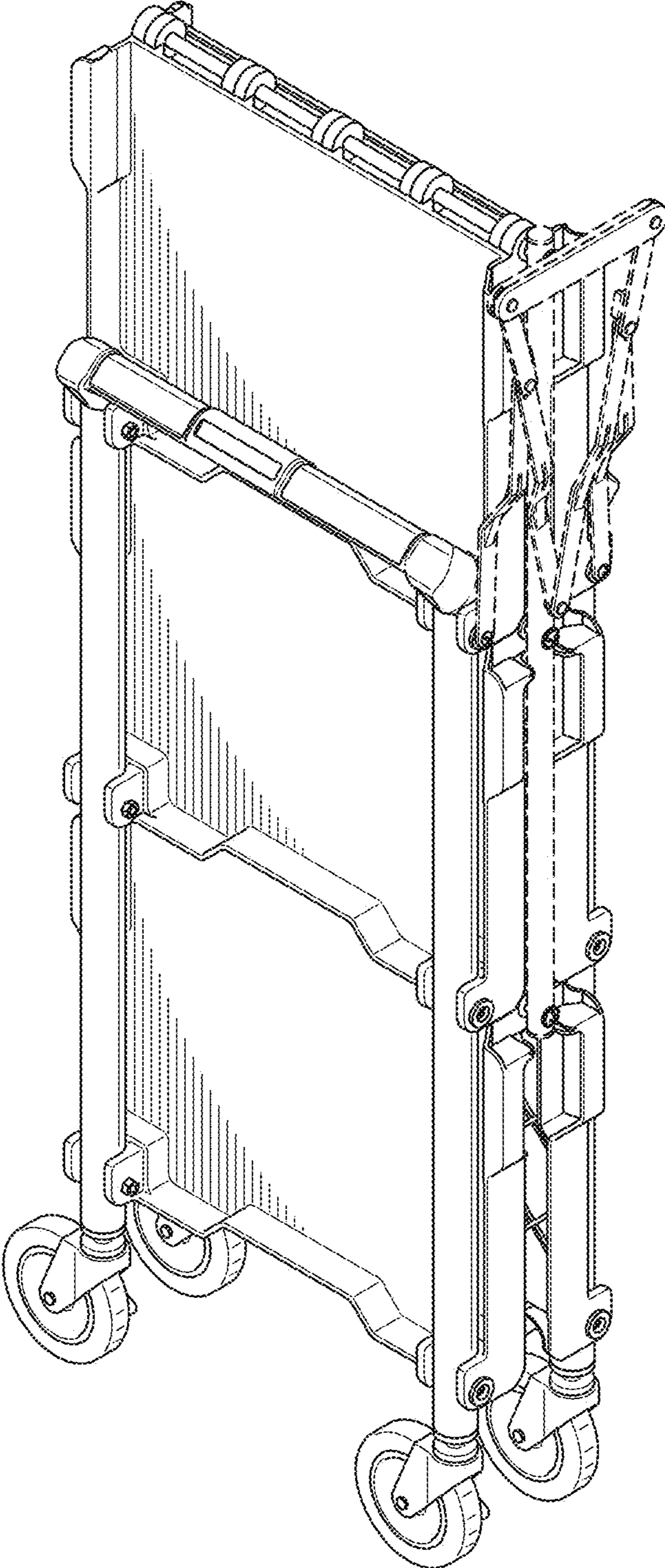

Fig. 12

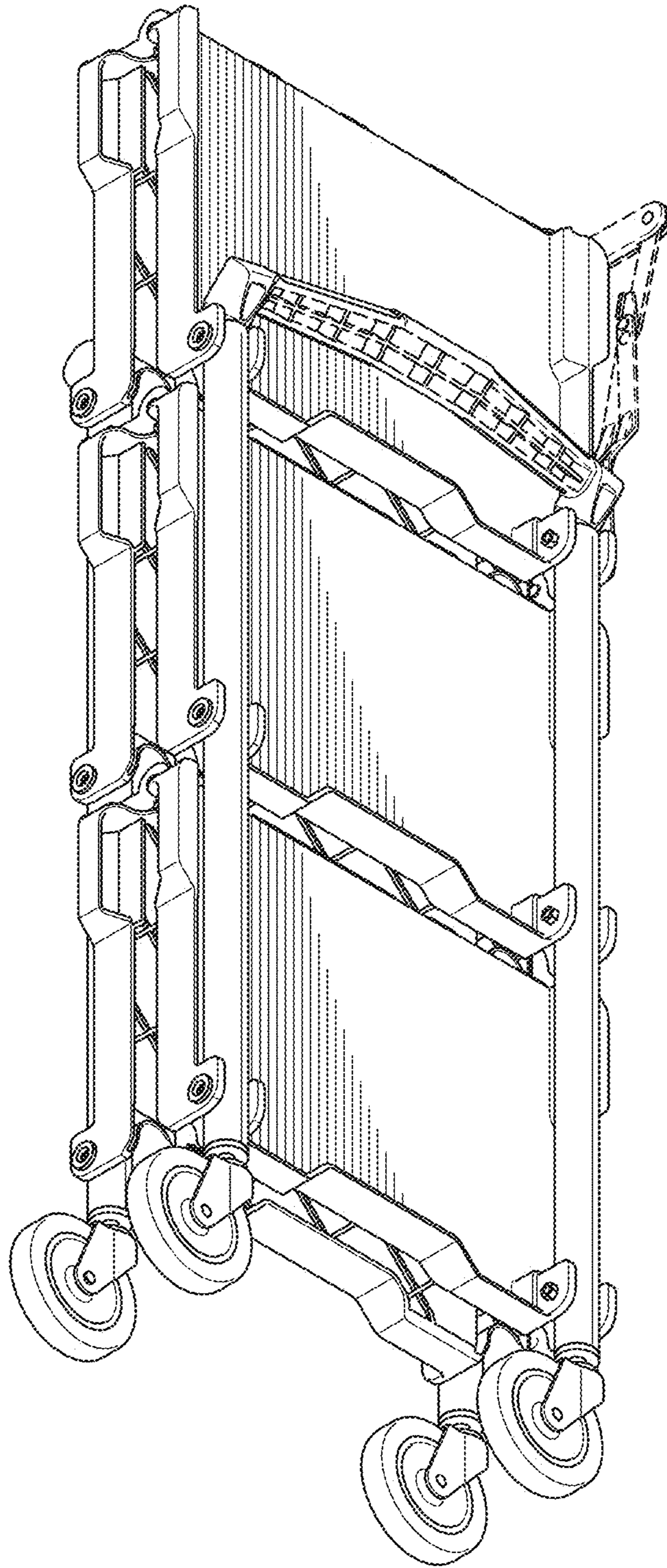

Fig. 13

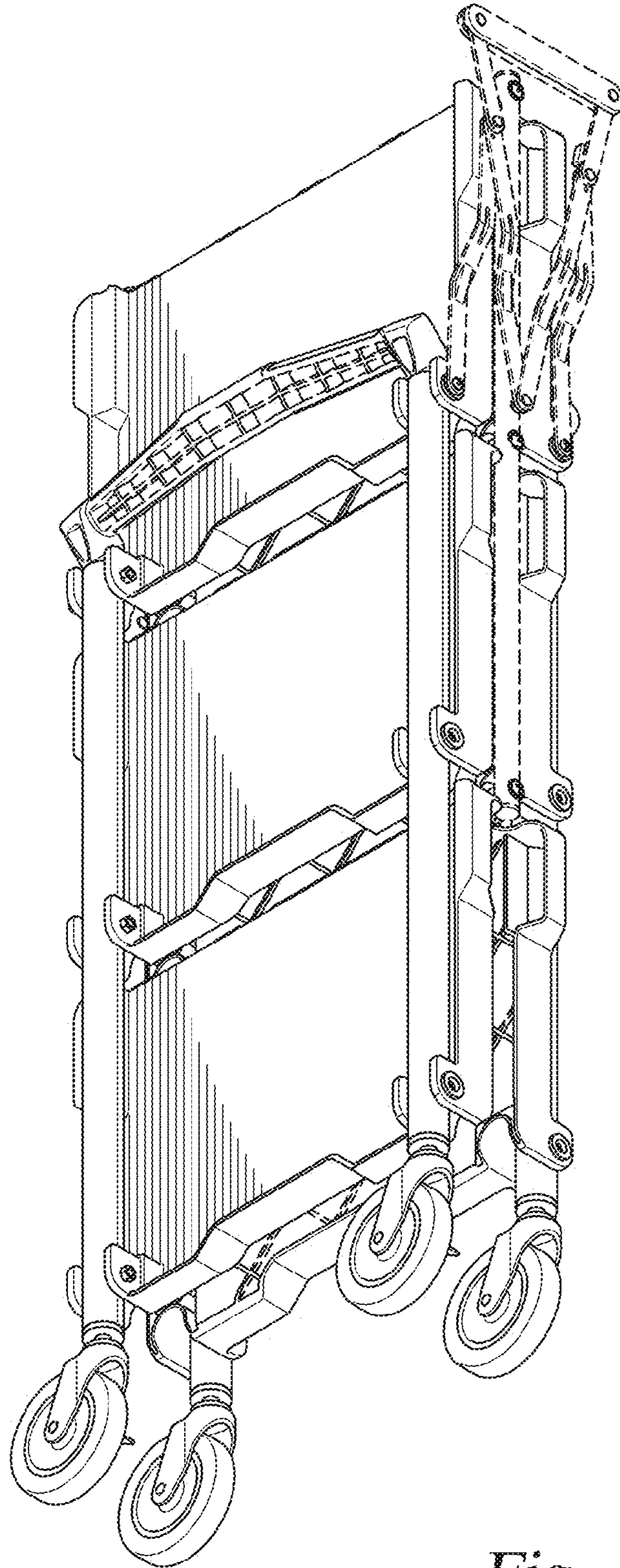

Fig. 14

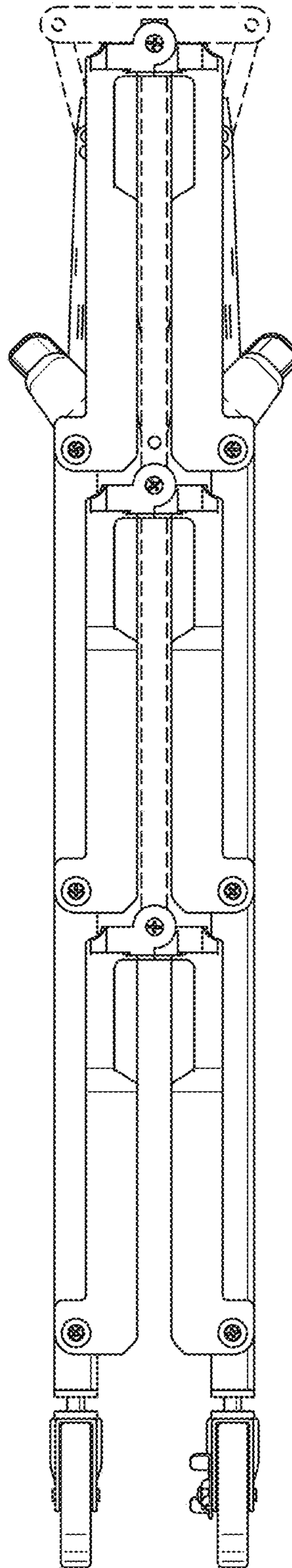

Fig. 15

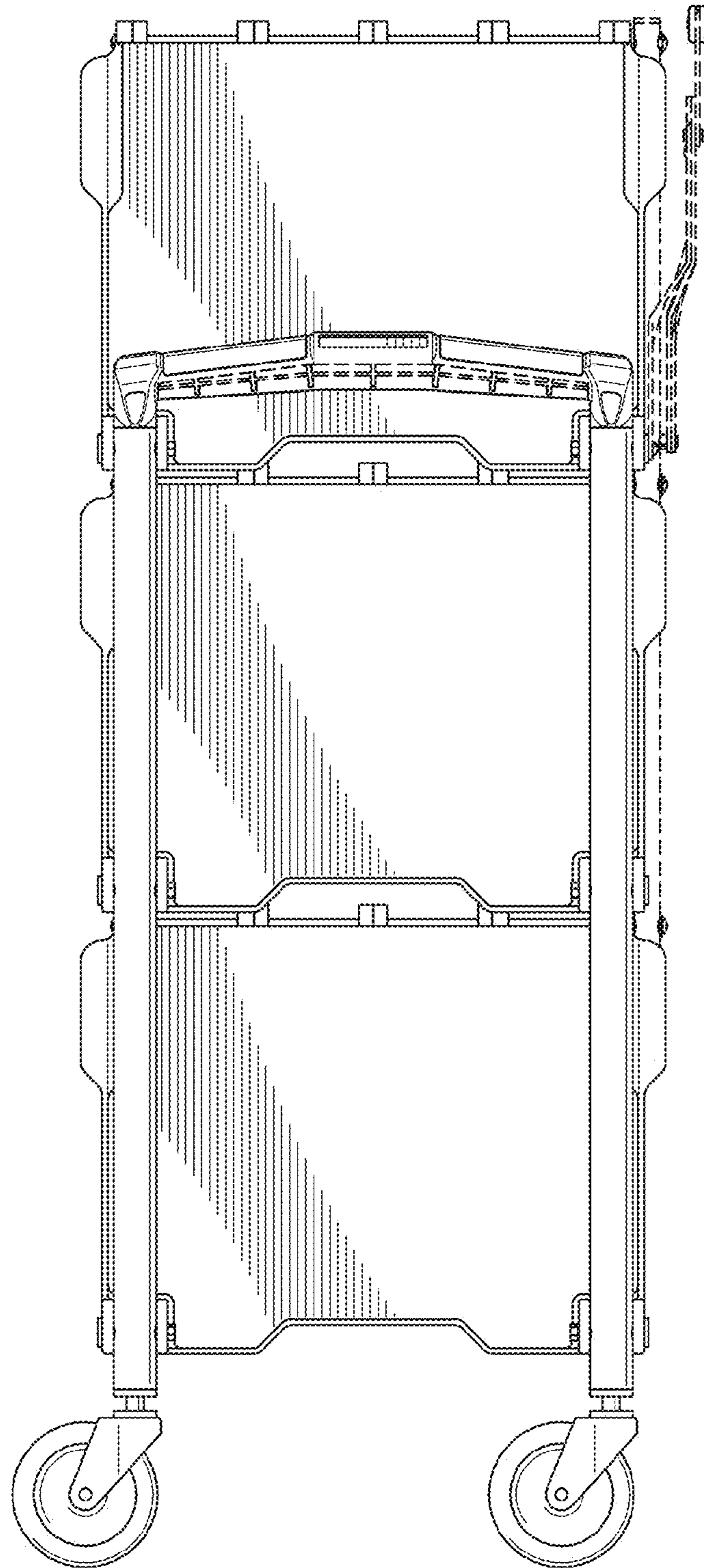

Fig. 16

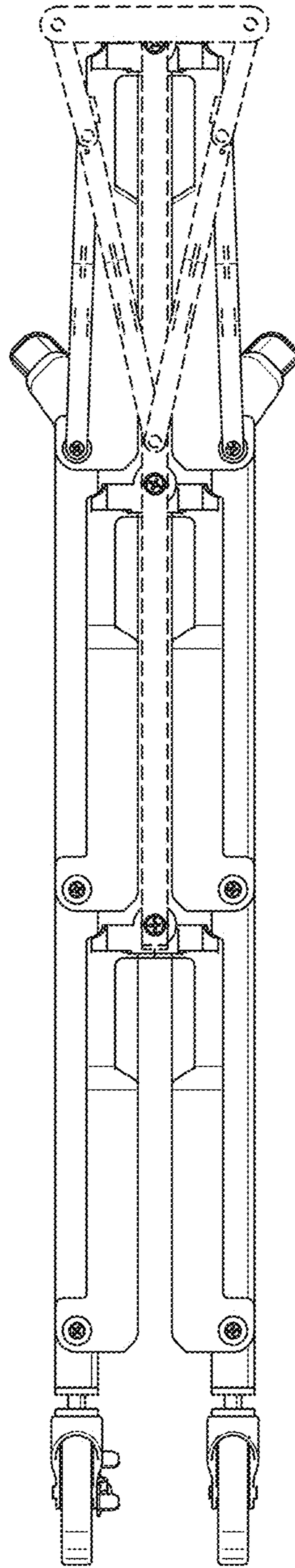

Fig. 17

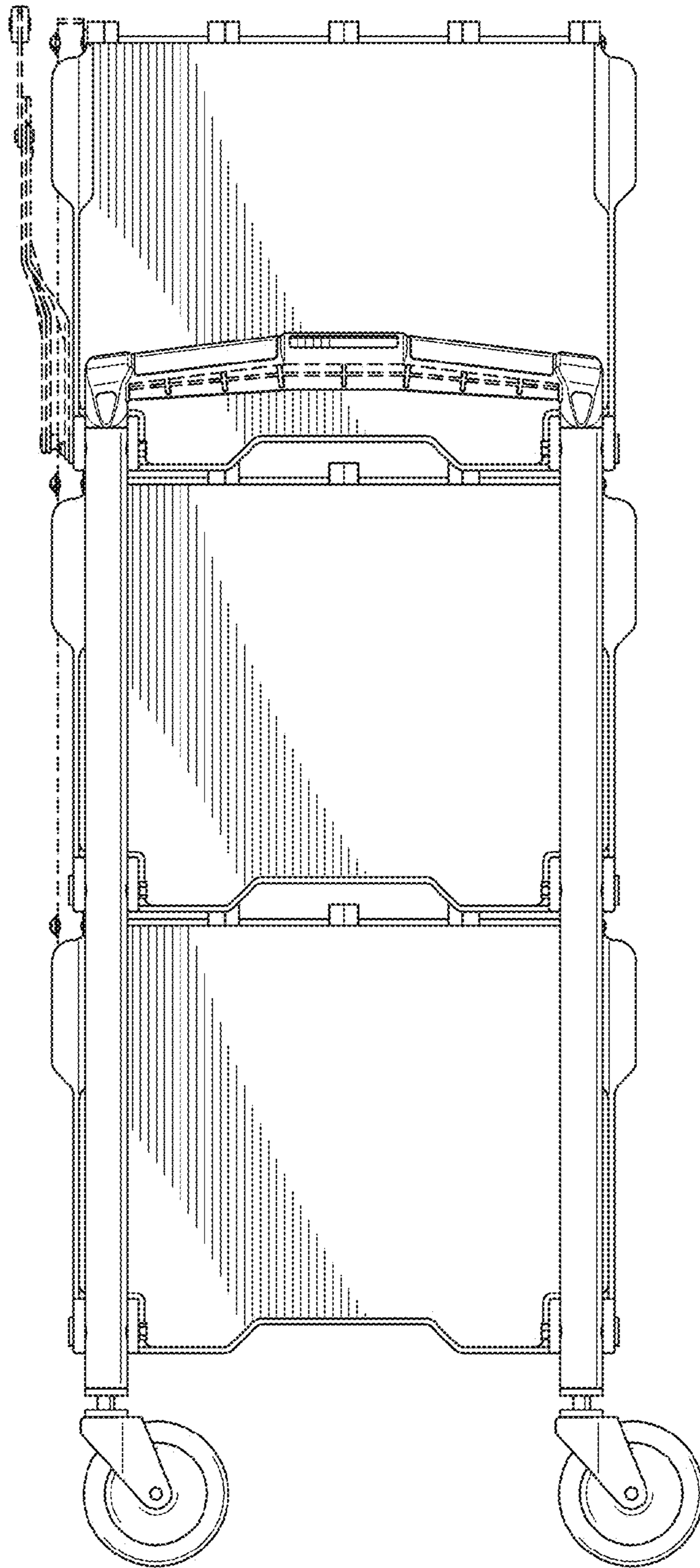

Fig. 18

Fig. 19

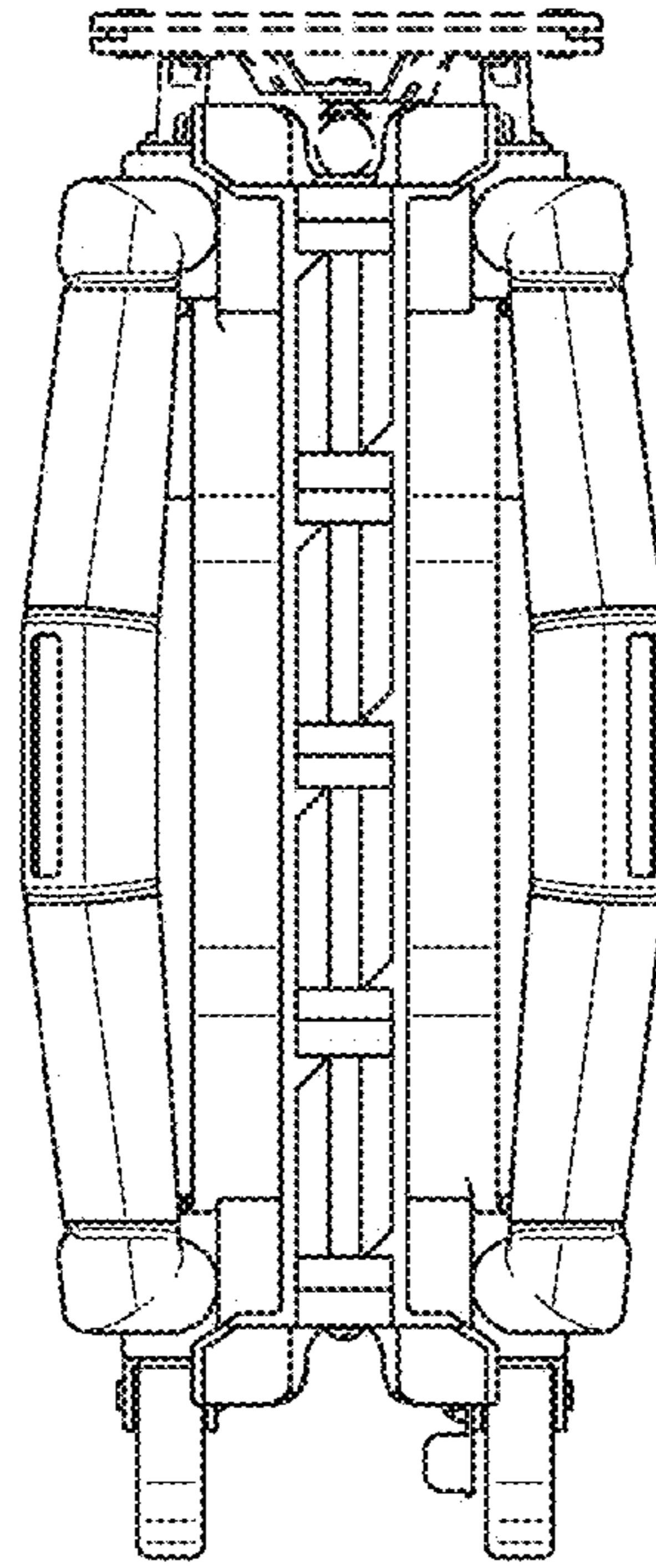

Fig. 20

