



US00D757933S

(12) **United States Design Patent**
Lev et al.

(10) **Patent No.:** **US D757,933 S**
(45) **Date of Patent:** **** May 31, 2016**

(54) **DUAL VIAL ADAPTER ASSEMBLAGE**

(71) Applicant: **MEDIMOP Medical Projects Ltd.,**
Ra'anana (IL)

(72) Inventors: **Nimrod Lev, Savion (IL); Mordechai**
Bukhman, Netanya (IL)

(73) Assignee: **Medimop Medical Projects Ltd.,**
Ra'anana (IL)

3,225,763 A	12/1965	Waterman
3,484,849 A	12/1969	Huebner et al.
3,618,637 A	11/1971	Santomieri
3,757,981 A	9/1973	Harris, Sr. et al.
3,788,524 A	1/1974	Davis et al.
3,822,700 A	7/1974	Pennington
3,826,261 A	7/1974	Killinger
3,872,992 A	3/1975	Larson
3,885,607 A	5/1975	Peltier
3,938,520 A	2/1976	Scislowicz et al.
3,957,052 A	5/1976	Topham

(Continued)

(**) Term: **14 Years**

FOREIGN PATENT DOCUMENTS

(21) Appl. No.: **29/502,037**

CN	1950049 A	4/2007
DE	1913926 A1	9/1970

(22) Filed: **Sep. 11, 2014**

(Continued)

(51) **LOC (10) Cl.** **24-02**

(52) **U.S. Cl.**

USPC **D24/129**

(58) **Field of Classification Search**

USPC D24/127-131, 112-114, 133, 186;
606/181, 185; 604/264, 523-528, 272,
604/187, 158, 164.01-164.11, 181, 184,
604/227; 600/101, 139, 143; 128/200.24,
128/207.14, 207.15

CPC A61M 25/00; A61M 39/00; A61M 27/00;
A61M 25/0043; A61M 25/0067; A61M
25/0097

See application file for complete search history.

Office Action issued Mar. 17, 2015 in U.S. Appl. No. 14/504,979 by Lev.

(Continued)

Primary Examiner — David Muller

(74) *Attorney, Agent, or Firm* — Panitch Schwarze Belisario & Nadel LLP

(57) **CLAIM**

The ornamental design for a dual vial adapter assemblage.

(56) **References Cited**

U.S. PATENT DOCUMENTS

62,333 A	2/1867	Holl
1,021,681 A	3/1912	Jennings
1,704,817 A	3/1929	Ayers
1,930,944 A	10/1933	Schmitz, Jr.
2,326,490 A	8/1943	Perelson
2,931,668 A	4/1960	Baley
2,968,497 A	1/1961	Treleman
3,059,643 A	10/1962	Barton
D198,499 S	6/1964	Harautuneian

DESCRIPTION

FIG. 1 is a front perspective view of a dual vial adapter assemblage in accordance with our new design;
FIG. 2 is a front elevational view thereof;
FIG. 3 is a rear elevational view thereof;
FIG. 4 is a left side elevational view thereof;
FIG. 5 is right side elevational view thereof;
FIG. 6 is a top plan view thereof; and,
FIG. 7 is a bottom plan view thereof.

1 Claim, 6 Drawing Sheets

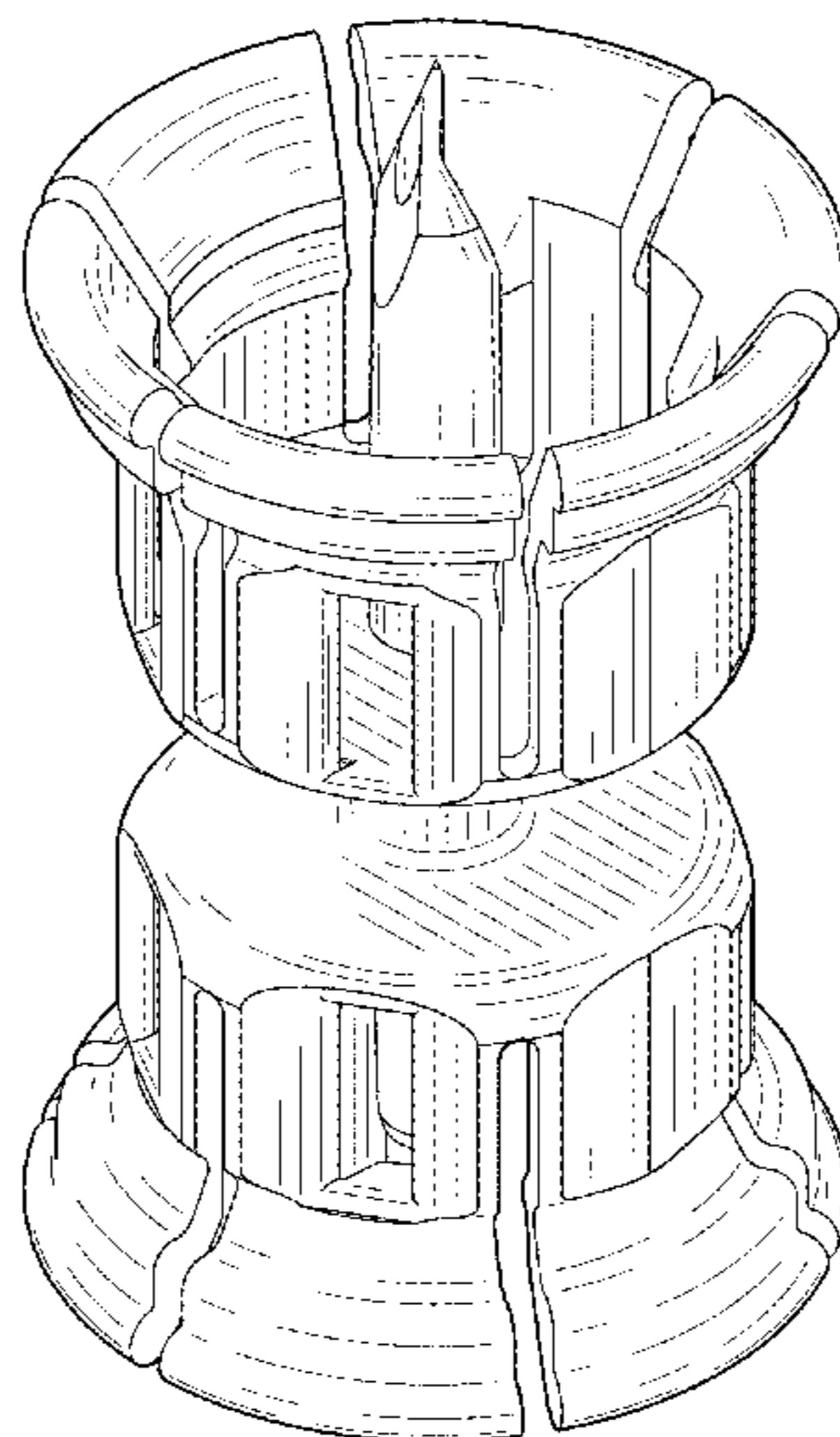

(56)

References Cited

U.S. PATENT DOCUMENTS

3,977,555 A	8/1976	Larson	D314,050 S	1/1991	Sone
3,993,063 A	11/1976	Larrabee	D314,622 S	2/1991	Andersson et al.
4,020,839 A	5/1977	Klapp	4,997,430 A	3/1991	Van der Heiden et al.
4,051,852 A	10/1977	Villari	5,006,114 A	4/1991	Rogers et al.
D248,568 S	7/1978	Ismach	5,035,686 A	7/1991	Crittenden et al.
4,109,670 A	8/1978	Slagel	5,041,105 A	8/1991	D'Alo et al.
4,121,585 A	10/1978	Becker, Jr.	5,045,066 A	9/1991	Scheuble et al.
4,161,178 A	7/1979	Genese	5,049,129 A	9/1991	Zdeb et al.
4,187,848 A	2/1980	Taylor	5,053,015 A	10/1991	Gross
4,203,067 A	5/1980	Fitzky et al.	5,061,248 A	10/1991	Sacco
4,203,443 A	5/1980	Genese	5,088,996 A	2/1992	Kopfer et al.
4,210,173 A	7/1980	Choksi et al.	5,096,575 A	3/1992	Cosack
D257,286 S	10/1980	Folkman	5,104,387 A	4/1992	Pokorney et al.
4,253,501 A	3/1981	Ogle	5,113,904 A	5/1992	Aslanian
4,296,786 A	10/1981	Brignola	5,122,124 A	6/1992	Novacek et al.
4,303,067 A	12/1981	Connolly et al.	5,125,908 A	6/1992	Cohen
4,312,349 A	1/1982	Cohen	5,125,915 A	6/1992	Berry et al.
4,314,586 A	2/1982	Folkman	D328,788 S	8/1992	Sagae et al.
4,328,802 A	5/1982	Curley et al.	5,171,230 A	12/1992	Eland et al.
4,335,717 A	6/1982	Bujan et al.	5,201,705 A	4/1993	Berglund et al.
D267,199 S	12/1982	Koenig	5,201,717 A	4/1993	Wyatt et al.
4,376,634 A	3/1983	Prior et al.	5,203,771 A	4/1993	Melker et al.
D268,871 S	5/1983	Benham et al.	5,203,775 A	4/1993	Frank et al.
4,392,850 A	7/1983	Elias et al.	5,211,638 A	5/1993	Dudar et al.
D270,282 S	8/1983	Gross	5,232,029 A	8/1993	Knox et al.
4,410,321 A	10/1983	Pearson et al.	5,232,109 A	8/1993	Tirrell et al.
4,411,662 A	10/1983	Pearson	5,242,432 A	9/1993	DeFrank
D271,421 S	11/1983	Fetterman	5,247,972 A	9/1993	Tetreault
4,434,823 A	3/1984	Hudspith	D341,420 S	11/1993	Conn
4,465,471 A	8/1984	Harris et al.	5,269,768 A	12/1993	Cheung
4,475,915 A	10/1984	Sloane	5,270,219 A	12/1993	DeCastro et al.
4,493,348 A	1/1985	Lemmons	5,279,576 A	1/1994	Loo et al.
4,505,709 A	3/1985	Froning et al.	5,288,290 A	2/1994	Brody
4,507,113 A	3/1985	Dunlap	5,300,034 A	4/1994	Behnke et al.
D280,018 S	8/1985	Scott	5,301,685 A	4/1994	Guirguis
4,532,969 A	8/1985	Kwaan	5,304,163 A	4/1994	Bonnici et al.
4,564,054 A	1/1986	Gustavsson	5,304,165 A	4/1994	Haber et al.
4,573,993 A	3/1986	Hoag et al.	5,308,483 A	5/1994	Sklar et al.
4,576,211 A	3/1986	Valentini et al.	5,312,377 A	5/1994	Dalton
4,581,014 A	4/1986	Millerd et al.	5,328,474 A	7/1994	Raines
4,588,396 A	5/1986	Stroebel et al.	D349,648 S	8/1994	Tirrell et al.
4,588,403 A	5/1986	Weiss et al.	5,334,163 A	8/1994	Sinnett
D284,603 S	7/1986	Loignon	5,334,179 A	8/1994	Poli et al.
4,604,093 A	8/1986	Brown et al.	5,342,346 A	8/1994	Honda et al.
4,607,671 A	8/1986	Aalto et al.	5,344,417 A	9/1994	Wadsworth, Jr.
4,614,437 A	9/1986	Buehler	5,348,548 A	9/1994	Meyer et al.
4,638,975 A	1/1987	Iuchi et al.	5,350,372 A	9/1994	Ikeda et al.
4,639,019 A	1/1987	Mittleman	5,364,386 A	11/1994	Fukuoka et al.
4,667,927 A	5/1987	Oscarsson	5,364,387 A	11/1994	Sweeney
4,676,530 A	6/1987	Nordgren et al.	5,374,264 A	12/1994	Wadsworth, Jr.
4,683,975 A	8/1987	Booth et al.	5,385,547 A	1/1995	Wong et al.
4,697,622 A	10/1987	Swift et al.	5,397,303 A	3/1995	Sancoff et al.
4,721,133 A	1/1988	Sundblom	D357,733 S	4/1995	Matkovich
4,729,401 A	3/1988	Raines	5,429,614 A	7/1995	Fowles et al.
4,735,608 A	4/1988	Sardam	5,433,330 A	7/1995	Yatsko et al.
4,743,229 A	5/1988	Chu	5,445,630 A	8/1995	Richmond
4,743,243 A	5/1988	Vaillancourt	5,445,631 A	8/1995	Uchida
4,752,292 A	6/1988	Lopez et al.	D362,718 S	9/1995	Deily et al.
4,758,235 A	7/1988	Tu	5,451,374 A	9/1995	Molina
4,759,756 A	7/1988	Forman et al.	5,454,805 A	10/1995	Brony
4,778,447 A	10/1988	Velde et al.	5,464,111 A	11/1995	Vacek et al.
4,787,898 A	11/1988	Raines	5,464,123 A	11/1995	Scarrow
4,797,898 A	1/1989	Martinez	5,466,219 A	11/1995	Lynn et al.
4,804,366 A	2/1989	Zdeb et al.	5,466,220 A	11/1995	Brenneman
4,832,690 A	5/1989	Kuu	5,470,327 A	11/1995	Helgren et al.
4,834,152 A	5/1989	Howson et al.	5,471,994 A	12/1995	Guirguis
D303,013 S	8/1989	Konopka	5,472,022 A	12/1995	Michel et al.
4,857,062 A	8/1989	Russell	5,478,337 A	12/1995	Okamoto et al.
4,865,592 A	9/1989	Rycroft	5,492,147 A	2/1996	Challender et al.
4,871,463 A	10/1989	Taylor et al.	D369,406 S	4/1996	Niedospial et al.
4,898,209 A	2/1990	Zbed	5,505,714 A	4/1996	Dassa et al.
4,909,290 A	3/1990	Coccia	5,509,433 A	4/1996	Paradis
4,931,040 A	6/1990	Haber et al.	5,520,659 A	5/1996	Hedges
4,932,944 A	6/1990	Jagger et al.	5,526,853 A	6/1996	McPhee et al.
4,967,797 A	11/1990	Manska	5,527,306 A	6/1996	Haining
			5,531,695 A	7/1996	Swisher
			5,547,471 A	8/1996	Thompson et al.
			5,549,577 A	8/1996	Siegel et al.
			5,554,128 A	9/1996	Hedges

(56)

References Cited

U.S. PATENT DOCUMENTS

5,566,729 A	10/1996	Grabenkort et al.	6,019,750 A	2/2000	Fowles et al.
5,569,191 A	10/1996	Meyer	6,022,339 A	2/2000	Fowles et al.
5,573,281 A	11/1996	Keller	6,036,171 A	3/2000	Weinheimer et al.
5,578,015 A	11/1996	Robb	6,039,093 A	3/2000	Mrotzek et al.
5,583,052 A	12/1996	Portnoff et al.	6,039,302 A	3/2000	Cote, Sr. et al.
5,584,819 A	12/1996	Kopfer	D422,357 S	4/2000	Niedospial, Jr. et al.
5,591,143 A	1/1997	Trombley, III et al.	6,063,068 A	5/2000	Fowles et al.
5,603,706 A	2/1997	Wyatt et al.	D427,308 S	6/2000	Zinger
5,607,439 A	3/1997	Yoon	D427,309 S	6/2000	Molina
5,611,576 A	3/1997	Guala	6,070,623 A	6/2000	Aneas
5,616,203 A	4/1997	Stevens	6,071,270 A	6/2000	Fowles et al.
5,636,660 A	6/1997	Pfleiderer et al.	6,080,132 A	6/2000	Cole et al.
5,637,101 A	6/1997	Shillington	D428,141 S	7/2000	Brotspies et al.
5,641,010 A	6/1997	Maier	6,086,762 A	7/2000	Guala
5,645,538 A	7/1997	Richmond	6,089,541 A	7/2000	Weinheimer et al.
5,647,845 A	7/1997	Haber et al.	6,090,091 A	7/2000	Fowles et al.
5,651,776 A	7/1997	Appling et al.	6,090,093 A	7/2000	Thibault et al.
5,653,686 A	8/1997	Coulter et al.	6,092,692 A	7/2000	Riskin
5,674,195 A	10/1997	Truthan	D430,291 S	8/2000	Jansen et al.
5,676,346 A	10/1997	Leinsing	6,099,511 A	8/2000	Devos et al.
5,685,845 A	11/1997	Grimard	6,113,068 A	9/2000	Ryan
D388,172 S	12/1997	Cipes	6,113,583 A	9/2000	Fowles et al.
5,699,821 A	12/1997	Paradis	6,117,114 A	9/2000	Paradis
5,702,019 A	12/1997	Grimard	D431,864 S	10/2000	Jansen
5,718,346 A	2/1998	Weiler	6,139,534 A	10/2000	Niedospial, Jr. et al.
D393,722 S	4/1998	Fangrow, Jr. et al.	6,142,446 A	11/2000	Leinsing
5,738,144 A	4/1998	Rogers	6,146,362 A	11/2000	Turnbull et al.
5,743,312 A	4/1998	Pfeifer et al.	6,149,623 A	11/2000	Reynolds
5,746,733 A	5/1998	Capaccio et al.	6,156,025 A	12/2000	Niedospial, Jr. et al.
5,755,696 A	5/1998	Caizza	6,159,192 A	12/2000	Fowles et al.
5,766,211 A	6/1998	Wood et al.	6,168,037 B1	1/2001	Grimard
5,772,630 A	6/1998	Ljungquist	6,171,287 B1	1/2001	Lynn et al.
5,772,652 A	6/1998	Zielinski	6,171,293 B1	1/2001	Rowley et al.
RE35,841 E	7/1998	Frank et al.	6,173,852 B1	1/2001	Browne
5,776,116 A	7/1998	Lopez et al.	6,173,868 B1	1/2001	DeJonge
5,782,872 A	7/1998	Muller	6,174,304 B1	1/2001	Weston
5,806,831 A	9/1998	Paradis	6,179,822 B1	1/2001	Niedospial, Jr.
5,810,792 A	9/1998	Fangrow, Jr. et al.	6,179,823 B1	1/2001	Niedospial, Jr.
D399,559 S	10/1998	Molina	6,206,861 B1	3/2001	Mayer
5,817,082 A	10/1998	Niedospial, Jr. et al.	6,221,041 B1	4/2001	Russo
5,820,621 A	10/1998	Yale et al.	6,221,054 B1	4/2001	Martin et al.
5,827,262 A	10/1998	Neftel et al.	6,221,065 B1	4/2001	Davis
5,832,971 A	11/1998	Yale et al.	6,238,372 B1	5/2001	Zinger et al.
5,833,213 A	11/1998	Ryan	6,245,044 B1	6/2001	Daw et al.
5,834,744 A	11/1998	Risman	D445,501 S	7/2001	Niedospial, Jr.
5,839,715 A	11/1998	Leinsing	D445,895 S	7/2001	Svensden
5,853,406 A	12/1998	Masuda et al.	6,253,804 B1	7/2001	Safabash
D405,522 S	2/1999	Hoening et al.	6,258,078 B1	7/2001	Thilly
5,871,110 A	2/1999	Grimard et al.	6,280,430 B1	8/2001	Neftel et al.
5,873,872 A	2/1999	Thibault et al.	6,290,688 B1	9/2001	Lopez et al.
5,879,337 A	3/1999	Kuracina et al.	6,296,621 B1	10/2001	Masuda et al.
5,879,345 A	3/1999	Aneas	6,299,131 B1	10/2001	Ryan
5,887,633 A	3/1999	Yale et al.	6,343,629 B1	2/2002	Wessman et al.
5,890,610 A	4/1999	Jansen et al.	6,348,044 B1	2/2002	Coletti et al.
5,891,129 A	4/1999	Daubert et al.	6,358,236 B1	3/2002	DeFoggi et al.
5,893,397 A	4/1999	Peterson et al.	6,364,866 B1	4/2002	Furr et al.
5,897,526 A	4/1999	Vaillancourt	6,378,576 B2	4/2002	Thibault et al.
5,899,468 A	5/1999	Apps et al.	6,378,714 B1	4/2002	Jansen et al.
5,902,280 A	5/1999	Powles et al.	6,379,340 B1	4/2002	Zinger et al.
5,902,298 A	5/1999	Niedospial, Jr. et al.	D457,954 S	5/2002	Wallace et al.
D410,740 S	6/1999	Molina	6,382,442 B1	5/2002	Thibault et al.
5,911,710 A	6/1999	Barry et al.	6,386,397 B2	5/2002	Brotspies et al.
5,919,182 A	7/1999	Avallone	6,408,897 B1	6/2002	Laurent et al.
5,921,419 A	7/1999	Niedospial, Jr. et al.	6,409,708 B1	6/2002	Wessman
5,924,584 A	7/1999	Hellstrom et al.	6,440,107 B1	8/2002	Trombley, III et al.
5,925,029 A	7/1999	Jansen et al.	6,453,949 B1	9/2002	Chau
5,935,112 A	8/1999	Stevens et al.	6,453,956 B2	9/2002	Safabash
5,941,848 A	8/1999	Nishimoto et al.	6,474,375 B2	11/2002	Spero et al.
5,944,700 A	8/1999	Nguyen et al.	6,478,788 B1	11/2002	Aneas
5,954,104 A	9/1999	Daubert et al.	D468,015 S	12/2002	Horppu
5,971,181 A	10/1999	Niedospial, Jr. et al.	6,499,617 B1	12/2002	Niedospial, Jr. et al.
5,971,965 A	10/1999	Mayer	6,503,240 B1	1/2003	Niedospial, Jr. et al.
5,989,237 A	11/1999	Fowles et al.	6,503,244 B2	1/2003	Hayman
6,003,566 A	12/1999	Thibault et al.	6,520,932 B2	2/2003	Taylor
6,004,278 A	12/1999	Botich et al.	6,524,278 B1	2/2003	Campbell et al.
			6,524,295 B2	2/2003	Daubert et al.
			D472,316 S	3/2003	Douglas et al.
			6,530,903 B2	3/2003	Wang et al.
			6,537,263 B1	3/2003	Aneas

(56)

References Cited

U.S. PATENT DOCUMENTS

D472,630 S	4/2003	Douglas et al.	7,354,422 B2	4/2008	Riesenberger et al.
6,544,246 B1	4/2003	Niedospial, Jr.	7,354,427 B2	4/2008	Fangrow
6,551,299 B2	4/2003	Miyoshi et al.	7,425,209 B2	9/2008	Fowles et al.
6,558,365 B2	5/2003	Zinger et al.	7,435,246 B2	10/2008	Zihlmann
6,571,837 B2	6/2003	Jansen et al.	D580,558 S	11/2008	Shigesada et al.
6,572,591 B2	6/2003	Mayer	7,452,348 B2	11/2008	Hasegawa
6,575,955 B2	6/2003	Azzolini	7,470,257 B2	12/2008	Norton et al.
6,581,593 B1	6/2003	Rubin et al.	7,470,265 B2	12/2008	Brugger et al.
6,582,415 B1	6/2003	Fowles et al.	7,472,932 B2	1/2009	Weber et al.
D476,731 S	7/2003	Cise et al.	7,488,297 B2	2/2009	Flaherty
6,591,876 B2	7/2003	Safabash	7,491,197 B2	2/2009	Jansen et al.
6,599,273 B1	7/2003	Lopez	7,497,848 B2	3/2009	Leinsing et al.
6,601,721 B2	8/2003	Jansen et al.	7,523,967 B2	4/2009	Steppe
6,626,309 B1	9/2003	Jansen et al.	7,530,546 B2	5/2009	Ryan et al.
6,638,244 B1	10/2003	Reynolds	D595,420 S	6/2009	Suzuki et al.
D482,121 S	11/2003	Harding et al.	D595,421 S	6/2009	Suzuki et al.
D482,447 S	11/2003	Harding et al.	7,540,863 B2	6/2009	Haindl
6,651,956 B2	11/2003	Miller	7,540,865 B2	6/2009	Griffin et al.
6,652,509 B1	11/2003	Helgren et al.	7,544,191 B2	6/2009	Peluso et al.
D483,487 S	12/2003	Harding et al.	D595,862 S	7/2009	Suzuki et al.
D483,869 S	12/2003	Tran et al.	D595,863 S	7/2009	Suzuki et al.
6,656,433 B2	12/2003	Sasso	7,611,487 B2	11/2009	Woehr et al.
6,666,852 B2	12/2003	Niedospial, Jr.	7,611,502 B2	11/2009	Daly
6,681,810 B2	1/2004	Weston	7,615,041 B2	11/2009	Sullivan et al.
6,681,946 B1	1/2004	Jansen et al.	7,628,779 B2	12/2009	Aneas
6,682,509 B2	1/2004	Lopez	7,632,261 B2	12/2009	Zinger et al.
6,692,478 B1	2/2004	Paradis	D608,900 S	1/2010	Giraud et al.
6,692,829 B2	2/2004	Stubler et al.	7,654,995 B2	2/2010	Warren et al.
6,695,829 B2	2/2004	Hellstrom et al.	7,670,326 B2	3/2010	Shemesh
6,699,229 B2	3/2004	Zinger et al.	7,695,445 B2	4/2010	Yuki
6,706,022 B1	3/2004	Leinsing et al.	D616,090 S	5/2010	Kawamura
6,706,031 B2	3/2004	Manera	7,713,247 B2	5/2010	Lopez
6,715,520 B2	4/2004	Andreasson et al.	7,717,886 B2	5/2010	Lopez
6,729,370 B2	5/2004	Norton et al.	7,722,090 B2	5/2010	Burton et al.
6,736,798 B2	5/2004	Ohkubo et al.	D616,984 S	6/2010	Gilboa
6,745,998 B2	6/2004	Doyle	7,731,678 B2	6/2010	Tennican et al.
6,746,438 B1	6/2004	Arnisolle	7,743,799 B2	6/2010	Mosler et al.
6,752,180 B2	6/2004	Delay	7,744,581 B2	6/2010	Wallen et al.
D495,416 S	8/2004	Dimeo et al.	7,757,901 B2	7/2010	Welp
D496,457 S	9/2004	Prais et al.	7,758,082 B2	7/2010	Weigel et al.
6,802,490 B2	10/2004	Leinsing et al.	7,762,524 B2	7/2010	Cawthon et al.
6,832,994 B2	12/2004	Niedospial, Jr. et al.	7,766,304 B2	8/2010	Phillips
6,852,103 B2	2/2005	Fowles et al.	7,771,383 B2	8/2010	Truitt et al.
6,875,203 B1	4/2005	Fowles et al.	D624,641 S	9/2010	Boclet
6,875,205 B2	4/2005	Leinsing	7,799,009 B2	9/2010	Niedospial, Jr. et al.
6,878,131 B2	4/2005	Novacek et al.	7,803,140 B2	9/2010	Fangrow, Jr.
6,890,328 B2	5/2005	Fowles et al.	D627,216 S	11/2010	Fulginiti
D506,256 S	6/2005	Miyoshi et al.	D630,732 S	1/2011	Lev et al.
6,901,975 B2	6/2005	Aramata et al.	7,862,537 B2	1/2011	Zinger et al.
6,945,417 B2	9/2005	Jansen et al.	7,867,215 B2	1/2011	Akerlund et al.
6,948,522 B2	9/2005	Newbrough et al.	7,879,018 B2	2/2011	Zinger et al.
6,949,086 B2	9/2005	Ferguson et al.	D634,007 S	3/2011	Zinger et al.
6,951,613 B2	10/2005	Reif et al.	7,900,659 B2	3/2011	Whitley et al.
6,957,745 B2	10/2005	Thibault et al.	D637,713 S	5/2011	Nord et al.
RE38,996 E	2/2006	Crawford et al.	D641,080 S	7/2011	Zinger et al.
6,994,315 B2	2/2006	Ryan et al.	7,985,216 B2	7/2011	Daily et al.
6,997,916 B2	2/2006	Simas, Jr. et al.	D644,104 S	8/2011	Maeda et al.
6,997,917 B2	2/2006	Niedospial, Jr. et al.	7,993,328 B2	8/2011	Whitley
7,024,968 B2	4/2006	Raudabough et al.	8,007,461 B2	8/2011	Huo et al.
7,070,589 B2	7/2006	Lolachi et al.	8,012,132 B2	9/2011	Lum et al.
7,074,216 B2	7/2006	Fowles et al.	8,016,809 B2	9/2011	Zinger et al.
7,083,600 B2	8/2006	Meloul	8,021,325 B2	9/2011	Zinger et al.
7,086,431 B2	8/2006	D'Antonio et al.	8,025,653 B2	9/2011	Capitaine et al.
7,100,890 B2	9/2006	Cote, Sr. et al.	8,029,472 B2	10/2011	Leinsing et al.
7,140,401 B2	11/2006	Wilcox et al.	8,038,123 B2	10/2011	Ruschke et al.
7,150,735 B2	12/2006	Hickle	8,066,688 B2	11/2011	Zinger et al.
7,192,423 B2	3/2007	Wong	8,070,739 B2	12/2011	Zinger et al.
7,195,623 B2	3/2007	Burroughs et al.	8,075,550 B2	12/2011	Nord et al.
7,241,285 B1	7/2007	Dikeman	8,096,525 B2	1/2012	Ryan
7,294,122 B2	11/2007	Kubo et al.	8,105,314 B2	1/2012	Fangrow, Jr.
7,306,199 B2	12/2007	Leinsing et al.	D654,166 S	2/2012	Lair
D561,348 S	2/2008	Zinger et al.	D655,017 S	2/2012	Mosler et al.
7,326,188 B1	2/2008	Russell et al.	8,122,923 B2	2/2012	Kraus et al.
7,326,194 B2	2/2008	Zinger et al.	8,123,736 B2	2/2012	Kraushaar et al.
7,350,764 B2	4/2008	Raybuck	8,157,784 B2	4/2012	Rogers
			8,167,863 B2	5/2012	Yow
			8,172,824 B2	5/2012	Pfeifer et al.
			8,177,768 B2	5/2012	Leinsing
			8,182,452 B2	5/2012	Mansour et al.

(56)

References Cited

U.S. PATENT DOCUMENTS

8,187,248	B2	5/2012	Zihlmann	2003/0195479	A1	10/2003	Kuracina et al.
8,196,614	B2	6/2012	Kriheli	2003/0199846	A1	10/2003	Fowles et al.
8,197,459	B2	6/2012	Jansen et al.	2003/0199847	A1	10/2003	Akerlund et al.
8,211,069	B2	7/2012	Fangrow, Jr.	2004/0024354	A1	2/2004	Reynolds
8,225,959	B2	7/2012	Lambrecht	2004/0039365	A1	2/2004	Aramata et al.
8,241,268	B2	8/2012	Whitley	2004/0044327	A1	3/2004	Hasegawa
8,262,628	B2	9/2012	Fangrow, Jr.	2004/0073189	A1	4/2004	Wyatt et al.
8,262,641	B2	9/2012	Vedrine et al.	2004/0143226	A1	7/2004	Marsden
8,267,127	B2	9/2012	Kriheli	2004/0153047	A1	8/2004	Blank et al.
D669,980	S	10/2012	Lev et al.	2004/0181192	A1	9/2004	Cuppy
8,287,513	B2	10/2012	Ellstrom et al.	2004/0204699	A1	10/2004	Hanly et al.
D673,673	S	1/2013	Wang	2004/0217315	A1	11/2004	Doyle
D674,088	S	1/2013	Lev et al.	2004/0225274	A1	11/2004	Jansen et al.
D681,230	S	4/2013	Mosler et al.	2004/0236305	A1	11/2004	Jansen et al.
8,454,573	B2	6/2013	Wyatt et al.	2004/0255952	A1	12/2004	Carlsen et al.
8,469,939	B2	6/2013	Fangrow, Jr.	2005/0015070	A1	1/2005	Delnevo et al.
8,475,404	B2	7/2013	Foshee et al.	2005/0016626	A1	1/2005	Wilcox et al.
8,480,645	B1	7/2013	Choudhury et al.	2005/0055008	A1	3/2005	Paradis et al.
8,480,646	B2	7/2013	Nord et al.	2005/0082828	A1	4/2005	Wicks et al.
8,506,548	B2	8/2013	Okiyama	2005/0124964	A1	6/2005	Niedospial et al.
8,511,352	B2	8/2013	Kraus et al.	2005/0137566	A1	6/2005	Fowles et al.
8,512,309	B2	8/2013	Shemesh et al.	2005/0148994	A1	7/2005	Leinsing
D690,418	S	9/2013	Rosenquist	2005/0159724	A1	7/2005	Enerson
8,523,837	B2	9/2013	Wiggins et al.	2005/0182383	A1	8/2005	Wallen
8,545,476	B2	10/2013	Ariagno et al.	2005/0209554	A1	9/2005	Landau
8,551,067	B2	10/2013	Zinger et al.	2005/0261637	A1	11/2005	Miller
8,556,879	B2	10/2013	Okiyama	2005/0277896	A1	12/2005	Messerli et al.
8,562,582	B2	10/2013	Tuckwell et al.	2006/0030832	A1	2/2006	Niedospial et al.
8,608,723	B2	12/2013	Lev et al.	2006/0079834	A1	4/2006	Tennican et al.
8,628,508	B2	1/2014	Weitzel et al.	2006/0089594	A1	4/2006	Landau
8,684,992	B2	4/2014	Sullivan et al.	2006/0089603	A1	4/2006	Truitt et al.
8,684,994	B2	4/2014	Lev et al.	2006/0095015	A1	5/2006	Hobbs et al.
8,752,598	B2	6/2014	Denenburg et al.	2006/0106360	A1	5/2006	Wong
D714,935	S *	10/2014	Nishioka D24/130	2006/0135948	A1	6/2006	Varma
D717,406	S	11/2014	Stanley et al.	2006/0155257	A1	7/2006	Reynolds
D717,948	S *	11/2014	Strong D24/130	2006/0155257	A1	7/2006	Reynolds
D719,650	S *	12/2014	Arinobe D24/130	2006/0155257	A1	7/2006	Reynolds
D720,067	S *	12/2014	Rosenquist D24/129	2006/0253084	A1	11/2006	Nordgren
D720,451	S *	12/2014	Denenburg D24/129	2006/0253084	A1	11/2006	Nordgren
D720,452	S *	12/2014	Jordan D24/130	2007/0024995	A1	2/2007	Hayashi
8,900,212	B2	12/2014	Kubo	2007/0060904	A1	3/2007	Vedrine et al.
D720,850	S	1/2015	Hsia et al.	2007/0079894	A1	4/2007	Kraus et al.
D732,660	S *	6/2015	Ohashi D24/112	2007/0083164	A1	4/2007	Barrelle et al.
D732,664	S *	6/2015	Woehr D24/130	2007/0088252	A1	4/2007	Pestotnik et al.
D733,291	S *	6/2015	Wang D24/129	2007/0088293	A1	4/2007	Fangrow
D733,292	S *	6/2015	Rogers D24/129	2007/0088313	A1	4/2007	Zinger et al.
D733,293	S *	6/2015	Rogers D24/129	2007/0106244	A1	5/2007	Mosler et al.
D738,494	S *	9/2015	Kashmirian D24/127	2007/0112324	A1	5/2007	Hamedi-Sangsari
D750,235	S *	2/2016	Maurice D24/129	2007/0156112	A1	7/2007	Walsh
2001/0000347	A1	4/2001	Hellstrom et al.	2007/0167904	A1	7/2007	Zinger et al.
2001/0025671	A1	10/2001	Safabash	2007/0191760	A1	8/2007	Iguchi et al.
2001/0029360	A1	10/2001	Miyoshi et al.	2007/0191764	A1	8/2007	Zihlmann
2001/0051793	A1	12/2001	Weston	2007/0191767	A1	8/2007	Hennessy et al.
2002/0017328	A1	2/2002	Loo	2007/0203451	A1	8/2007	Murakami et al.
2002/0066715	A1	6/2002	Niedospial	2007/0219483	A1	9/2007	Kitani et al.
2002/0087118	A1	7/2002	Reynolds et al.	2007/0244447	A1	10/2007	Capitaine et al.
2002/0087141	A1	7/2002	Zinger et al.	2007/0244461	A1	10/2007	Fangrow
2002/0087144	A1	7/2002	Zinger et al.	2007/0244462	A1	10/2007	Fangrow
2002/0121496	A1	9/2002	Thiebault et al.	2007/0244463	A1	10/2007	Warren et al.
2002/0123736	A1	9/2002	Fowles et al.	2007/0249995	A1	10/2007	Van Manen
2002/0127150	A1	9/2002	Sasso	2007/0255202	A1	11/2007	Kitani et al.
2002/0128628	A1	9/2002	Fathallah	2007/0265574	A1	11/2007	Tennican et al.
2002/0138045	A1	9/2002	Moen	2007/0265581	A1	11/2007	Funamura et al.
2002/0173752	A1	11/2002	Polzin	2007/0270778	A9	11/2007	Zinger et al.
2002/0193777	A1	12/2002	Aneas	2007/0287953	A1	12/2007	Ziv et al.
2003/0028156	A1	2/2003	Juliar	2007/0299404	A1	12/2007	Katoh et al.
2003/0036725	A1	2/2003	Lavi et al.	2008/0009789	A1	1/2008	Zinger et al.
2003/0068354	A1	4/2003	Reif et al.	2008/0009822	A1	1/2008	Enerson
2003/0073971	A1	4/2003	Saker	2008/0135051	A1	6/2008	Lee
2003/0100866	A1	5/2003	Reynolds	2008/0172024	A1	7/2008	Yow
2003/0109846	A1	6/2003	Zinger et al.	2008/0188799	A1	8/2008	Mueller-Beckhaus et al.
2003/0120209	A1	6/2003	Jensen et al.	2008/0249479	A1	10/2008	Zinger et al.
2003/0153895	A1	8/2003	Leinsing	2008/0249498	A1	10/2008	Fangrow
2003/0187420	A1	10/2003	Akerlund et al.	2008/0262465	A1	10/2008	Zinger et al.
2003/0191445	A1	10/2003	Wallen et al.	2008/0287905	A1	11/2008	Hiejima et al.
				2008/0294100	A1	11/2008	de Costa et al.
				2008/0306439	A1	12/2008	Nelson et al.
				2008/0312634	A1	12/2008	Helmerson et al.
				2009/0012492	A1	1/2009	Zihlmann
				2009/0082750	A1	3/2009	Denenburg et al.
				2009/0143758	A1	6/2009	Okiyama
				2009/0177177	A1	7/2009	Zinger et al.

(56)

References Cited

U.S. PATENT DOCUMENTS

2009/0177178 A1 7/2009 Pedersen
 2009/0187140 A1 7/2009 Racz
 2009/0216212 A1 8/2009 Fangrow, Jr.
 2009/0267011 A1 10/2009 Hatton et al.
 2009/0299325 A1 12/2009 Vedrine et al.
 2009/0326506 A1 12/2009 Hasegawa et al.
 2010/0010443 A1 1/2010 Morgan et al.
 2010/0022985 A1 1/2010 Sullivan et al.
 2010/0030181 A1 2/2010 Helle et al.
 2010/0036319 A1 2/2010 Drake et al.
 2010/0076397 A1 3/2010 Reed et al.
 2010/0087786 A1 4/2010 Zinger et al.
 2010/0137827 A1 6/2010 Warren et al.
 2010/0160889 A1 6/2010 Smith et al.
 2010/0168664 A1 7/2010 Zinger et al.
 2010/0168712 A1 7/2010 Tuckwell et al.
 2010/0179506 A1 7/2010 Shemesh et al.
 2010/0198148 A1 8/2010 Zinger et al.
 2010/0204670 A1 8/2010 Kraushaar et al.
 2010/0241088 A1 9/2010 Ranalletta et al.
 2010/0274184 A1 10/2010 Chun
 2010/0286661 A1 11/2010 Raday et al.
 2010/0312220 A1 12/2010 Kalitzki
 2011/0004184 A1 1/2011 Proksch et al.
 2011/0054440 A1 3/2011 Lewis
 2011/0087164 A1 4/2011 Mosler et al.
 2011/0160701 A1 6/2011 Wyatt et al.
 2011/0175347 A1 7/2011 Okiyama
 2011/0218511 A1 9/2011 Yokoyama
 2011/0224640 A1 9/2011 Kuhn et al.
 2011/0230856 A1 9/2011 Kyle et al.
 2011/0264037 A1 10/2011 Foshee et al.
 2011/0264069 A1 10/2011 Bochenko
 2011/0276007 A1 11/2011 Denenburg
 2011/0319827 A1 12/2011 Leinsing et al.
 2012/0022469 A1 1/2012 Alpert
 2012/0053555 A1 3/2012 Ariagno et al.
 2012/0059346 A1 3/2012 Sheppard et al.
 2012/0067429 A1 3/2012 Mosler et al.
 2012/0078214 A1 3/2012 Finke et al.
 2012/0123382 A1 5/2012 Kubo
 2012/0184938 A1 7/2012 Lev et al.
 2012/0215182 A1 8/2012 Mansour et al.
 2012/0220977 A1 8/2012 Yow
 2012/0220978 A1 8/2012 Lev et al.
 2012/0265163 A1 10/2012 Cheng et al.
 2012/0271229 A1 10/2012 Lev et al.
 2012/0296307 A1 11/2012 Holt et al.
 2012/0310203 A1 12/2012 Khaled et al.
 2012/0323187 A1 12/2012 Iwase et al.
 2012/0323210 A1 12/2012 Lev et al.
 2013/0046269 A1 2/2013 Lev et al.
 2013/0053814 A1 2/2013 Mueller-Beckhaus et al.
 2013/0096493 A1 4/2013 Kubo et al.
 2013/0144248 A1 6/2013 Putter et al.
 2013/0199669 A1 8/2013 Moy et al.
 2013/0226100 A1 8/2013 Lev
 2013/0231630 A1 9/2013 Kraus et al.
 2013/0237904 A1 9/2013 Deneburg et al.
 2013/0289530 A1 10/2013 Wyatt et al.
 2014/0020793 A1 1/2014 Denenburg et al.
 2014/0096862 A1 4/2014 Aneas
 2014/0150911 A1 6/2014 Hanner et al.
 2014/0352845 A1 12/2014 Lev et al.
 2015/0082746 A1 3/2015 Ivosevic et al.
 2015/0088078 A1 3/2015 Lev et al.

FOREIGN PATENT DOCUMENTS

DE 4122476 A1 1/1993
 DE 19504413 A1 8/1996
 DE 202004012714 U1 11/2004
 DE 202009011019 U1 12/2010
 EP 0192661 A1 9/1986

EP 0195018 A1 9/1986
 EP 0258913 A2 3/1988
 EP 0416454 A2 3/1991
 EP 0518397 A1 12/1992
 EP 0521460 A1 1/1993
 EP 0637443 A1 2/1995
 EP 0737467 A1 10/1996
 EP 761562 A1 3/1997
 EP 765652 A1 4/1997
 EP 765853 A1 4/1997
 EP 0806597 A1 11/1997
 EP 0814866 A1 1/1998
 EP 829248 A2 3/1998
 EP 0856331 A2 8/1998
 EP 882441 A2 12/1998
 EP 0887085 A2 12/1998
 EP 897708 A2 2/1999
 EP 0898951 A2 3/1999
 EP 960616 A2 12/1999
 EP 1008337 A1 6/2000
 EP 1029526 A1 8/2000
 EP 1034809 A1 9/2000
 EP 1051988 A2 11/2000
 EP 1323403 A1 7/2003
 EP 1329210 A1 7/2003
 EP 1396250 A1 3/2004
 EP 1454609 A1 9/2004
 EP 1454650 A1 9/2004
 EP 1498097 A2 1/2005
 EP 1872824 A1 1/2008
 EP 1911432 A1 4/2008
 EP 1919432 A1 5/2008
 EP 1930038 A2 6/2008
 EP 2090278 A1 8/2009
 EP 2351548 A1 8/2011
 EP 2351549 A1 8/2011
 EP 2462913 A1 6/2012
 FR 2029242 A5 10/1970
 FR 2856660 A1 12/2004
 FR 2869795 A1 11/2005
 FR 2931363 A1 11/2009
 GB 1444210 A 7/1976
 IL 171662 10/2005
 JP 03-062426 B 9/1991
 JP 4329954 A 11/1992
 JP 06-050656 U 7/1994
 JP H08-000710 A 1/1996
 JP 09-104460 A 4/1997
 JP 09-104461 A 4/1997
 JP 10-118158 A 5/1998
 JP H10-504736 A 5/1998
 JP 11503627 T 3/1999
 JP 11-319031 A 11/1999
 JP 2000-508934 A 7/2000
 JP 2000-237278 A 9/2000
 JP 2001-505083 A 4/2001
 JP 2002-035140 A 2/2002
 JP 2002-516160 A 6/2002
 JP 2002-355318 A 12/2002
 JP 2003-033441 A 2/2003
 JP 2003-102807 A 4/2003
 JP 2004-097253 A 4/2004
 JP 2004-522541 A 7/2004
 JP 2010-179128 A 8/2010
 WO 8601712 A1 3/1986
 WO 9003536 A1 4/1990
 WO 9403373 A1 2/1994
 WO 9507066 A1 3/1995
 WO 9600053 A1 1/1996
 WO 9629113 A1 9/1996
 WO 9736636 A1 10/1997
 WO 9832411 A1 7/1998
 WO 9837854 A1 9/1998
 WO 9961093 A1 12/1999
 WO 0128490 A1 4/2001
 WO 0130425 A1 5/2001
 WO 0132524 A1 5/2001
 WO 0160311 A1 8/2001
 WO 0191693 A2 12/2001

(56)

References Cited

FOREIGN PATENT DOCUMENTS

WO	200209797	A1	2/2002
WO	0232372	A1	4/2002
WO	0236191	A2	5/2002
WO	02066100	A2	8/2002
WO	02089900	A1	11/2002
WO	03051423	A2	6/2003
WO	03070147	A2	8/2003
WO	03079956	A1	10/2003
WO	2004041148	A1	5/2004
WO	2005002492	A1	1/2005
WO	2005041846	A2	5/2005
WO	2005105014	A2	11/2005
WO	2006099441	A2	9/2006
WO	2007015233	A1	2/2007
WO	2007017868	A1	2/2007
WO	2007052252	A1	5/2007
WO	2007101772	A1	9/2007
WO	2007105221	A1	9/2007
WO	2008081424	A2	7/2008
WO	2008126090	A1	10/2008
WO	2009026443	A2	2/2009
WO	2009029010	A1	3/2009
WO	2009038860	A2	3/2009
WO	2009040804	A2	4/2009
WO	2009087572	A1	7/2009
WO	2009093249	A1	7/2009
WO	2009112489	A1	9/2009
WO	2009146088	A1	12/2009
WO	2010061743	A1	6/2010
WO	2010117580	A1	10/2010
WO	2011039747	A1	4/2011
WO	2011058545	A1	5/2011
WO	2011058548	A1	5/2011
WO	2011077434	A1	6/2011
WO	2011104711	A1	9/2011
WO	2012063230	A1	5/2012
WO	201243921	A1	10/2012
WO	2013127813	A1	9/2013
WO	2013134246	A1	9/2013
WO	2013156944	A1	10/2013
WO	2014033706	A2	3/2014
WO	2014033710	A1	3/2014

OTHER PUBLICATIONS

Office Action issued Apr. 9, 2015 in U.S. Appl. No. 13/883,289 by Lev.

Office Action issued May 28, 2015 in U.S. Appl. No. 14/391,792 by Lev.

Written Opinion issued Jul. 31, 2013 in Int'l Application No. PCT/IL2013/050313.

Int'l Preliminary Report on Patentability issued May 12, 2014 in Int'l Application No. PCT/IL2013/050316.

Office Action issued Jul. 31, 2014 in U.S. Appl. No. 29/438,141 by Gilboa.

U.S. Appl. No. 14/385,212 by Lev, filed Sep. 15, 2014.

U.S. Appl. No. 29/502,053 by Lev, filed Sep. 11, 2014.

Office Action issued Aug. 24, 2015 in U.S. Appl. No. 14/366,306 by Lev.

Office Action issued Mar. 10, 2015 in EP Application No. 12 812 395.7.

Office Action issued Aug. 7, 2015 in JP Application No. 2015-529206.

U.S. Appl. No. 14/391,792 by Lev, filed Oct. 10, 2014.

U.S. Appl. No. 14/504,979 by Lev, filed Oct. 2, 2014.

Int'l Search Report and Written Opinion issued Sep. 2, 2014 in Int'l Application No. PCT/IL2014/050405.

Int'l Search Report and Written Opinion issued Oct. 17, 2014 in Int'l Application No. PCT/IL2014/050680.

English translation of an Office Action issued Aug. 28, 2014 in JP Application No. 2013-168885.

Written Opinion issued Jun. 5, 2013 in Int'l Application No. PCT/IL2012/050407.

Int'l Preliminary Report on Patentability issued Aug. 20, 2014 in Int'l Application No. PCT/IL2012/050407.

Office Action issued Jan. 2, 2015 in U.S. Appl. No. 29/438,141 by Gilboa.

Office Action issued Jan. 5, 2015 in U.S. Appl. No. 29/413,220 by Lev.

Office Action issued Jan. 7, 2015 in U.S. Appl. No. 29/438,134 by Lev.

U.S. Appl. No. 14/423,595 by Lev, filed Feb. 24, 2015.

U.S. Appl. No. 14/423,612 by Lev, filed Feb. 24, 2015.

U.S. Appl. No. 14/425,582 by Lev, filed Mar. 3, 2015.

Office Action issued Mar. 6, 2012 in U.S. Appl. No. 12/678,928.

Int'l Search Report issued Feb. 3, 2011 in Int'l Application No. PCT/IL2010/000777; Written Opinion.

Int'l Search Report issued Mar. 17, 2011 in Int'l Application No. PCT/IL2010/000854; Written Opinion.

Int'l Search Report issued Mar. 17, 2011 in Int'l Application No. PCT/IL2010/000915; Written Opinion.

U.S. Appl. No. 13/505,790 by Lev, filed May 3, 2012.

U.S. Appl. No. 13/505,881 by Lev, filed May 3, 2012.

U.S. Appl. No. 13/522,410 by Lev, filed Jul. 16, 2012.

U.S. Appl. No. 13/576,461 by Lev, filed Aug. 1, 2012.

Office Action issued Jun. 14, 2012 in U.S. Appl. No. 29/376,980.

Office Action issued Jun. 15, 2012 in U.S. Appl. No. 29/413,170.

Office Action issued Jun. 21, 2012 in U.S. Appl. No. 12/596,167.

Alaris Medical Systems Product Brochure, 4 pages, Issue 1, Oct. 11, 1999.

Smart Site Needle-Free Systems, Alaris Medical Systems Webpage, 4 pages, Feb. 2006.

Photographs of Alaris Medical Systems SmartSite.RTM. device, 5 pages, 2002.

Non-Vented Vial Access Pin with ULTRASITE.RTM. Valve, B. Braun Medical, Inc. website and product description, 3 pages, Feb. 2006.

Int'l Search Report issued Aug. 16, 2012 in Int'l Application No. PCT/IL2012/000164.

U.S. Appl. No. 29/438,134 by Lev, filed Nov. 27, 2012.

U.S. Appl. No. 29/438,141 by Gilboa, filed Nov. 27, 2012.

Int'l Search Report issued Jan. 22, 2013 in Int'l Application No. PCT/IL2012/000354.

Int'l Search Report issued Mar. 18, 2013 in Int'l Application No. PCT/IL2012/050516.

Office Action issued Apr. 2, 2013 in U.S. Appl. No. 13/505,790.

Int'l Search Report and Written Opinion issued Mar. 6, 2012 in Int'l Application No. PCT/IL2011/000834.

U.S. Appl. No. 13/883,289 by Lev, filed May 3, 2013.

Int'l Search Report & Written Opinion issued on Mar. 7, 2012 in Int'l Application No. PCT/IL2011/000829.

U.S. Appl. No. 13/884,981 by Denenburg, filed May 13, 2013.

Office Action issued May 31, 2013 in U.S. Appl. No. 13/505,790.

Int'l Search Report issued Jun. 5, 2013 in Int'l Application No. PCT/IL2012/050407.

Int'l Search Report issued Jun. 19, 2013 in Int'l Application No. PCT/IL2013/050167.

Int'l Search Report issued Jul. 1, 2013 in Int'l Application No. PCT/IL2013/050180.

Int'l Search Report issued Jul. 31, 2013 in Int'l Application No. PCT/IL2013/050313.

Int'l Search Report issued Jul. 26, 2013 in Int'l Application No. PCT/IL2013/050316.

English translation of an Office Action issued Jun. 19, 2013 in JP Application No. 2012-531551.

Office Action issued Aug. 20, 2013 in U.S. Appl. No. 13/576,461 by Lev.

Int'l Preliminary Report on Patentability issued Aug. 28, 2012 in Int'l Application No. PCT/IL2011/000186.

English translation of an Office Action issued Jul. 26, 2013 in JP Application No. 2012-538464.

International Search Report Issued Jan. 23, 2007 in Int'l Application No. PCT/IL/2006/001228.

(56)

References Cited

OTHER PUBLICATIONS

IV disposables sets catalogue, Cardinal Health, Alaris® products, SmartSite® access devices and accessories product No. 10013365, SmartSite add-on bag access device with spike adapter and needle-free valve bag access port, pp. 1-5, Fall edition (2007).

Drug Administration Systems product information sheets; <http://www.westpharma.com/eu/en/products/Pages/Vial2Bag.aspx>; pp. 1-3.

Office Action Issued Jun. 8, 2010 in U.S. Appl. No. 12/112,490 by Zinger.

Office Action issued Sep. 28, 2010 in U.S. Appl. No. 12/112,490 by Zinger.

Article with picture of West Pharmaceutical Services' Vial2Bag Needleless System, [on-line]; ISIPS Newsletter, Oct. 26, 2007]; retrieved from Internet Feb. 16, 2010]; URL:<http://www.isips.org/reports/ISIPS_Newsletter_October_26_2007.html> (7 pages. see pp. 5-6).

Office Action issued Jun. 15, 2011 in JP Application No. 2008-538492.

Translation of Office Action issued Jun. 18, 2012 in JP Application No. 2008-538492.

Translation of Office Action issued Apr. 15, 2013 in JP Application No. 2008-538492.

Office Action issued Jul. 13, 2012 in U.S. Appl. No. 12/112,490 by Zinger.

Office Action issued Jan. 23, 2013 in U.S. Appl. No. 12/112,490 by Zinger.

Int'l Preliminary Report on Patentability issued May 6, 2008 in Int'l Application No. PCT/IL2006/001228.

Written Opinion issued Aug. 16, 2012 in Int'l Application No. PCT/IL2012/000164.

English translation of an Office Action issued Sep. 10, 2013 in JP Application No. 2012-554468.

Office Action issued Nov. 11, 2013 in IL Application No. 218730.

Grifols Vial Adapter Product Literature, 2 pages, Jan. 2002.

Novel Transfer, Mixing and Drug Delivery Systems, MOP Medimop Medical Projects Ltd. Catalog, 4 pages, Rev. 4, 2004.

Office Action Issued Oct. 6, 2003 in U.S. Appl. No. 10/062,796.

Office Action Issued Feb. 22, 2005 in U.S. Appl. No. 10/062,796.

Office Action Issued Oct. 5, 2005 in U.S. Appl. No. 10/062,796.

Office Action Issued Feb. 20, 2009 in U.S. Appl. No. 11/694,297.

Int'l Search Report Issued Dec. 6, 2006 in Int'l Application No. PCT/IL2006/000912.

Int'l Preliminary Report on Patentability Issued Dec. 4, 2007 in Int'l Application No. PCT/IL2006/000912.

<http://www.westpharma.com/en/products/Pages/Mixject.aspx>.

<http://www.westpharma.com/SiteCollectionDocuments/Recon/mixject%20product%20sheet.pdf>; MIXJECT product information sheet pp. 1.

Int'l Search Report Issued Jul. 27, 2007 in Int'l Application No. PCT/IL2007/000343.

Int'l Preliminary Report on Patentability Issued Jun. 19, 2008 in Int'l Application No. PCT/IL2007/000343.

Int'l Search Report Issued Mar. 27, 2009 in Int'l Application No. PCT/US2008/070024.

Int'l Search Report Issued Oct. 17, 2005 in Int'l Application No. PCT/IL2005/000376.

Int'l Preliminary Report on Patentability Issued Jun. 19, 2006 in Int'l Application No. PCT/IL2005/000376.

Written Opinion of ISR Issued Jun. 19, 2006 in Int'l Application No. PCT/IL2005/000376.

Int'l Search Report Issued Aug. 25, 2008 in Int'l Application No. PCT/IL2008/000517.

Written Opinion of the ISR Issued Oct. 17, 2009 in Int'l Application No. PCT/IL08/00517.

Int'l Preliminary Report on Patentability Issued Oct. 20, 2009 in Int'l Application No. PCT/IL2008/000517.

Written Opinion of the Int'l Searching Authority Issued Oct. 27, 2008 in Int'l Application No. PCT/US2008/070024.

Int'l Search Report Issued Mar. 12, 2009 in Int'l Application No. PCT/IL2008/001278.

Office Action Issued Jan. 20, 2010 in JP Application No. 2007-510229.

Office Action Issued Apr. 20, 2010 in U.S. Appl. No. 11/997,569.

Int'l Search Report dated Nov. 20, 2006 in Int'l Application No. PCT/IL2006/000881.

Office Action Issued May 27, 2010 in U.S. Appl. No. 11/559,152.

Decision to Grant mailed Apr. 12, 2010 in EP Application No. 08738307.1.

Office Action issued Jun. 1, 2010 in U.S. Appl. No. 11/568,421.

Office Action issued Nov. 12, 2010 in U.S. Appl. No. 29/334,697.

The MixJect transfer system, as shown in the article, "Advanced Delivery Devices," Drug Delivery Technology Jul./Aug. 2007 vol. 7 No. 7 [on-line]. [Retrieved from Internet May 14, 2010.] URL:<<http://www.drugdeliverytech-online.com/drugdelivery/200707/?pg=28pg28>>. (3 pages).

Publication date of Israeli Patent Application 186290 [on-line]. [Retrieved from Internet May 24, 2010]. URL:<<http://www.ilpatsearch.justice.gov.il/UI/RequestsList.aspx>>. (1 page).

Int'l Search Report issued Nov. 25, 2010 in Int'l Application No. PCT/IL2010/000530.

Office Action issued Feb. 7, 2011 in U.S. Appl. No. 12/783,194.

Office Action issued Dec. 20, 2010 in U.S. Appl. No. 12/063,176.

Office Action issued Dec. 13, 2010 in U.S. Appl. No. 12/293,122.

Office Action issued Nov. 29, 2010 in U.S. Appl. No. 11/568,421.

Office Action issued Dec. 23, 2010 in U.S. Appl. No. 29/334,696.

Int'l Search Report issued on Mar. 17, 2011 in Int'l Application No. PCT/IL2010/000854.

Overview—Silicone Rubber [retrieved from http://www.knovel.com/web/portal/browse/display?_EXT_KNOVEL_DISPLAY_bookid=1023&VerticalID=0 on Feb. 9, 2011].

Int'l Search Report issued on Mar. 17, 2011 in Int'l Application No. PCT/IL2010/00915.

Office Action Issued May 12, 2011 in U.S. Appl. No. 12/063,176.

Office Action issued Jul. 11, 2011 in U.S. Appl. No. 12/293,122.

Int'l Search Report issued Jul. 12, 2011 in Int'l Application No. PCT/IL2011/000187.

Int'l Search Report issued Jul. 12, 2011 in Int'l Application No. PCT/IL2011/000186.

Office Action issued Aug. 3, 2011 in JP Application No. 2008-525719.

Int'l Search Report issued Oct. 7, 2011 in Int'l Application No. PCT/IL2011/000511.

Int'l Search Report issued Mar. 6, 2012 in Int'l Application No. PCT/IL2011/000834; Written Opinion.

Office Action issued Mar. 1, 2012 in JP Application No. 2007-510229.

Int'l Search Report issued Mar. 7, 2012 in Int'l Application No. PCT/IL2011/000829; Written Opinion.

Office Action issued Mar. 13, 2012 in CA Application No. 2,563,643.

Office Action issued Mar. 1, 2012 in CN Application No. 2008801108283.4.

U.S. Appl. No. 29/478,723 by Lev, filed Jan. 8, 2014.

U.S. Appl. No. 29/478,726 by Lev, filed Jan. 8, 2014.

Office Action issued Jan. 2, 2014 in U.S. Appl. No. 13/505,881 by Lev.

Int'l Preliminary Report on Patentability issued Sep. 24, 2013 in Int'l Application No. PCT/IL2012/000354.

Office Action issued Feb. 13, 2014 in U.S. Appl. No. 13/884,981 by Denenburg.

U.S. Appl. No. 14/345,094 by Lev, filed Mar. 14, 2014.

Int'l Search Report and Written Opinion issued Jan. 7, 2014 in Int'l Application No. PCT/IL2012/050721.

English translation of an Office Action issued Jan. 9, 2014 in JP Application No. 2010-526421.

English translation of an Office Action issued Dec. 4, 2013 in CN Application No. 201080051210.3.

English translation of an Office Action issued Dec. 25, 2013 in CN Application No. 201180006530.1.

Office Action issued Nov. 28, 2013 in IN Application No. 4348/DELNP/2008.

(56)

References Cited

OTHER PUBLICATIONS

Office Action issued Oct. 8, 2013 in CN Application No. 201080043825.1.

English translation of an Office Action issued Feb. 4, 2014 in JP Application No. 2012-554468.

Office Action issued Jan. 17, 2014 in CN Application No. 201180006534.X.

Int'l Search Report and Written Opinion issued May 8, 2014 in Int'l Application No. PCT/IL2013/050706.

English translation of an Office Action issued Apr. 28, 2014 in JP Application No. 2013-537257.

Int'l Preliminary Report on Patentability issued Jan. 14, 2014 in Int'l Application No. PCT/IL2012/050516.

Office Action issued May 6, 2014 in U.S. Appl. No. 13/505,881 by Lev.

U.S. Appl. No. 14/366,306 by Lev, filed Jun. 18, 2014.

Office Action issued Apr. 17, 2014 in CN Application No. 201080051201.4.

Int'l Search Report and Written Opinion issued Jul. 16, 2014 in Int'l Application No. PCT/IL2014/050327.

English translation of an Office Action issued Jun. 30, 2014 in CN Application No. 201180052962.6.

Extended European Search Report issued Jun. 3, 2014 in EP Application No. 08781828.2.

Written Opinion issued Jul. 1, 2013 in Int'l Application No. PCT/IL2013/050180.

Int'l Preliminary Report on Patentability issued Apr. 1, 2014 in Int'l Application No. PCT/IL2013/050180.

Office Action issued Dec. 9, 2015 in U.S. Appl. No. 29/478,723 by Lev.

West, Vial2Bag DC system, Oct. 2, 2014, <https://web.archive.org/web/20141002065133/http://www.westpharma.com/en/products/Pages/Reconstitutionsystems.aspx>.

Youtube.com, Vial2Bag DC, Aug. 21, 2014, <https://www.youtube.com/watch?v=FEOkglxNBrs>.

Office Action issued Dec. 9, 2015 in U.S. Appl. No. 29/478,726 by Lev.

Notice of Allowance issued Jan. 12, 2016 in U.S. Appl. No. 14/385,212 by Lev.

Written Opinion issued Apr. 10, 2015 in Int'l Application No. PCT/IL2014/050405.

Response to Written Opinion dated Mar. 9, 2015 in Int'l Application No. PCT/IL2014/050405.

Int'l Preliminary Report on Patentability issued Aug. 24, 2015 in Int'l Application No. PCT/IL2014/050405.

U.S. Appl. No. 14/888,590 by Marks, filed Nov. 2, 2015.

U.S. Appl. No. 14/784,300 by Lev, filed Oct. 14, 2015.

Office Action issued Oct. 5, 2015 in U.S. Appl. No. 14/385,212 by Lev.

U.S. Appl. No. 29/544,969 by Ben Shalom, filed Nov. 9, 2015.

Office Action issued Mar. 25, 2016 in U.S. Appl. No. 29/478,726 by LEV.

* cited by examiner

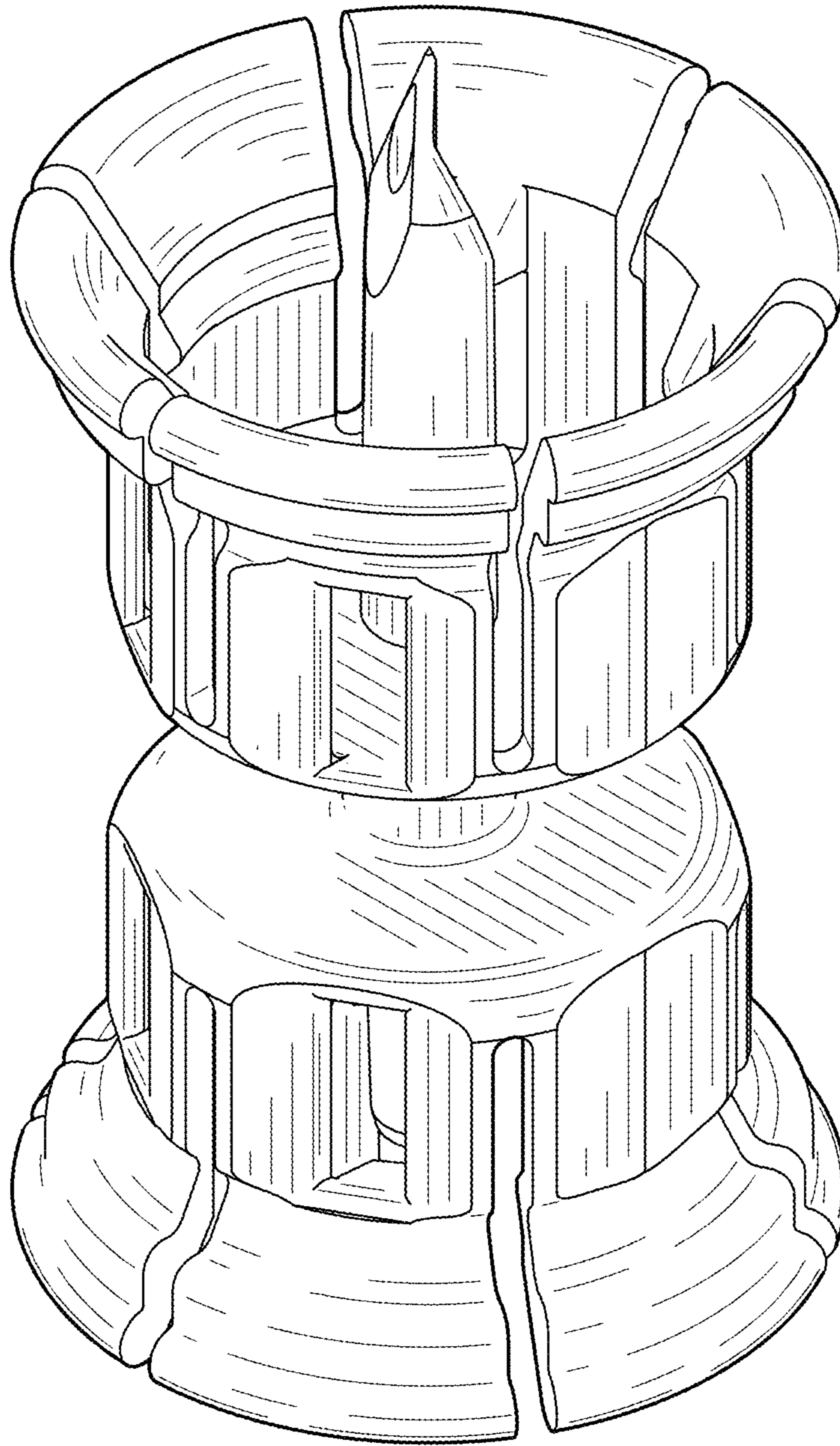

FIG.1

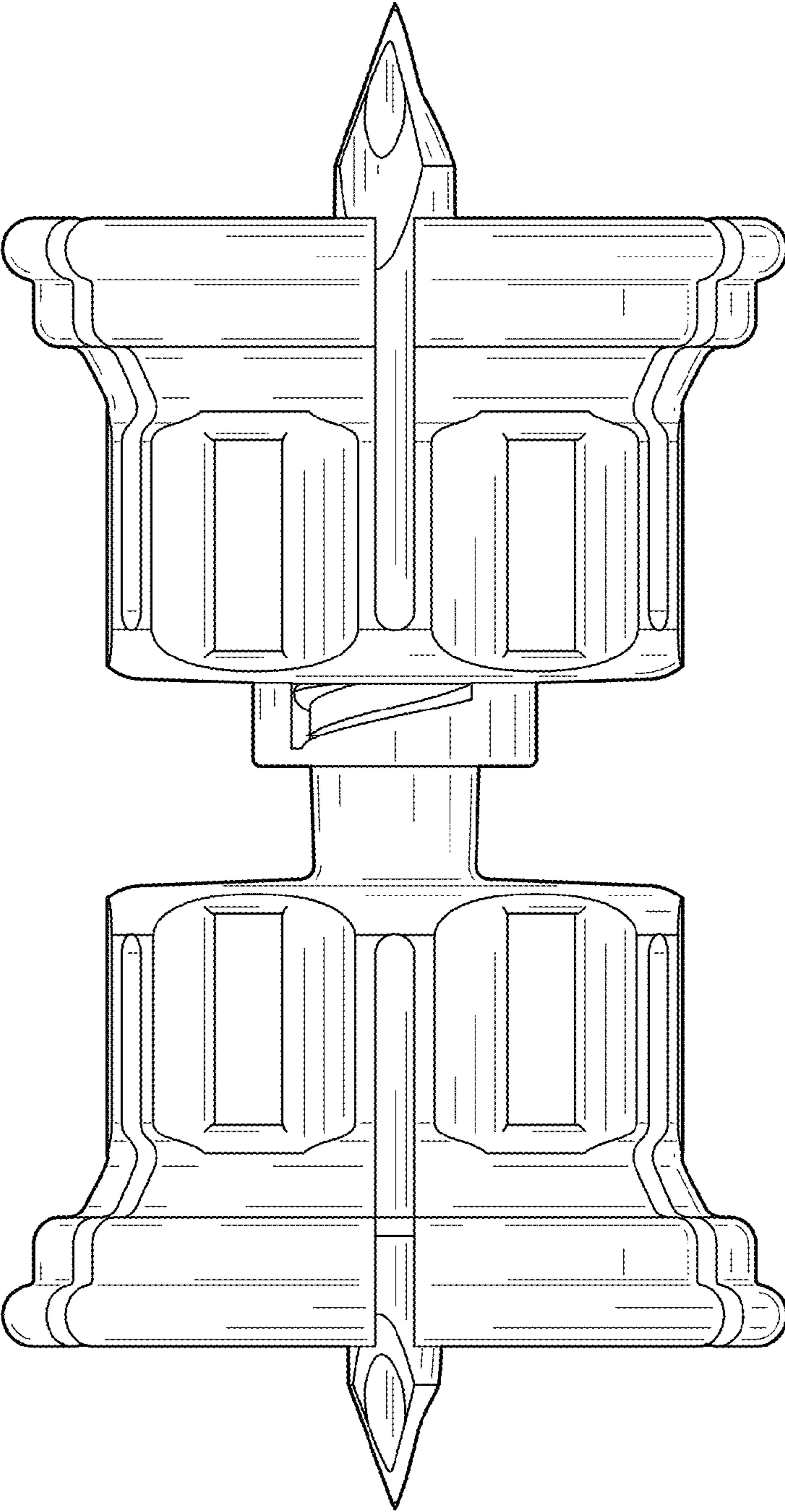

FIG. 2

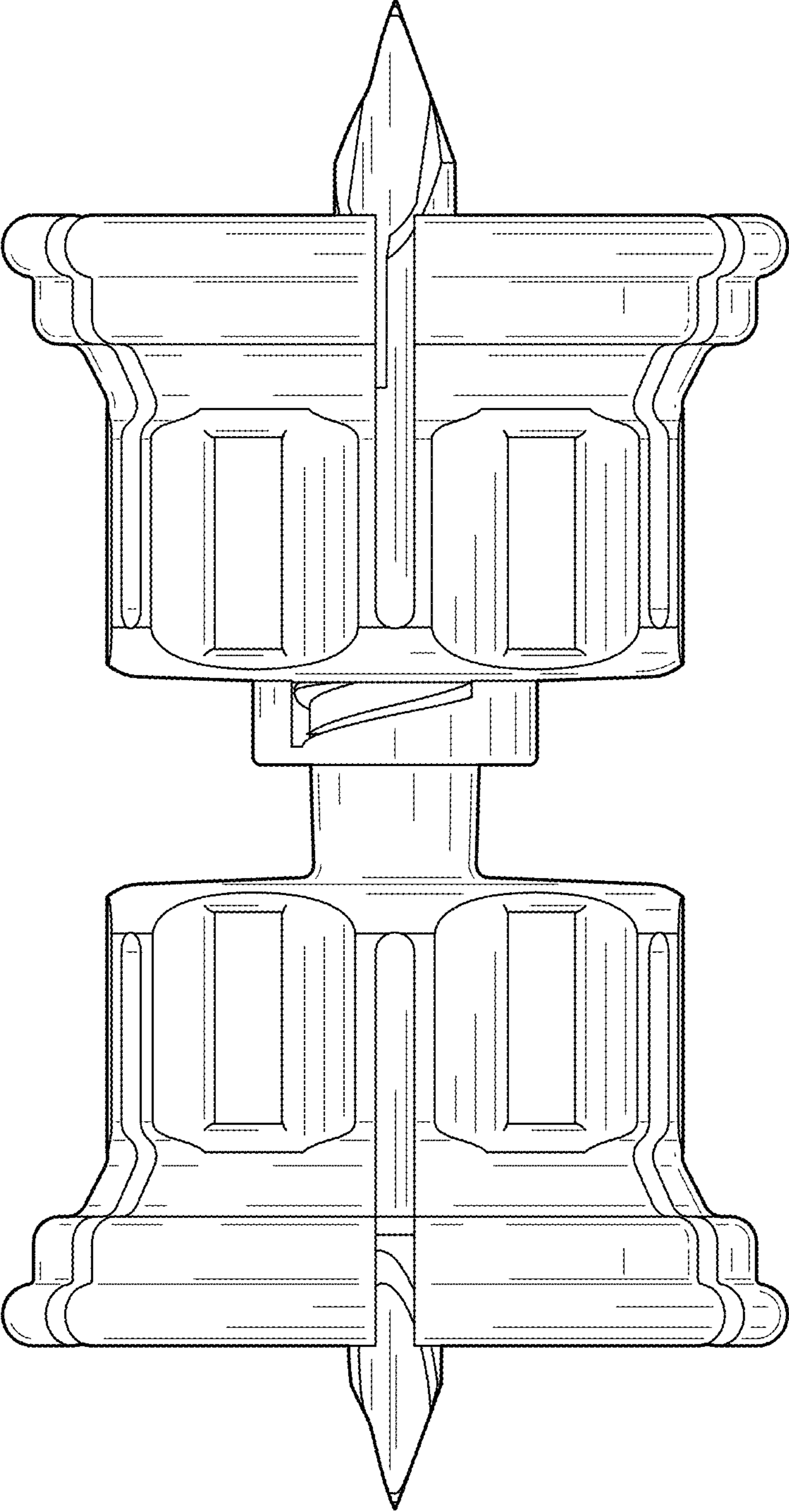

FIG. 3

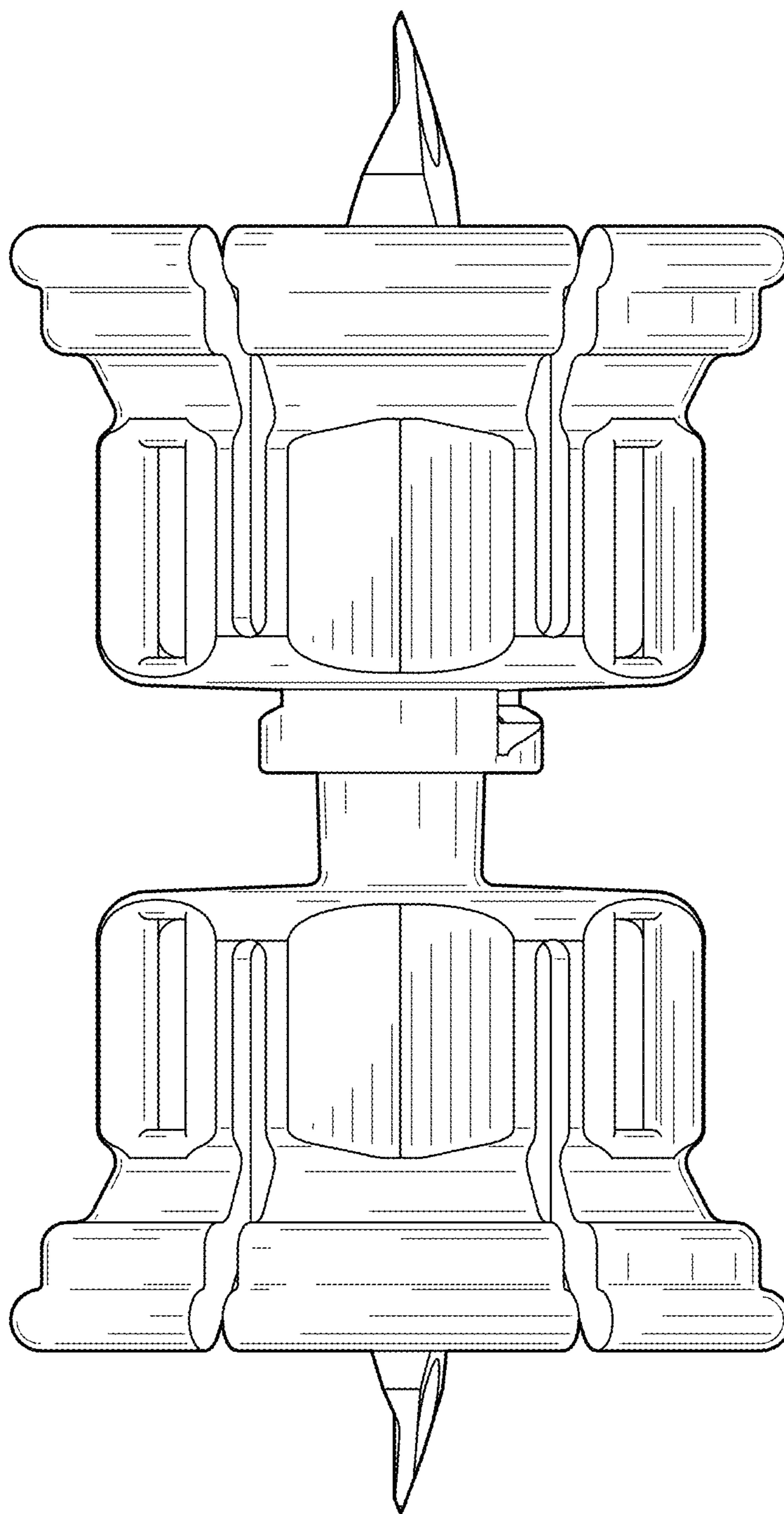

FIG. 4

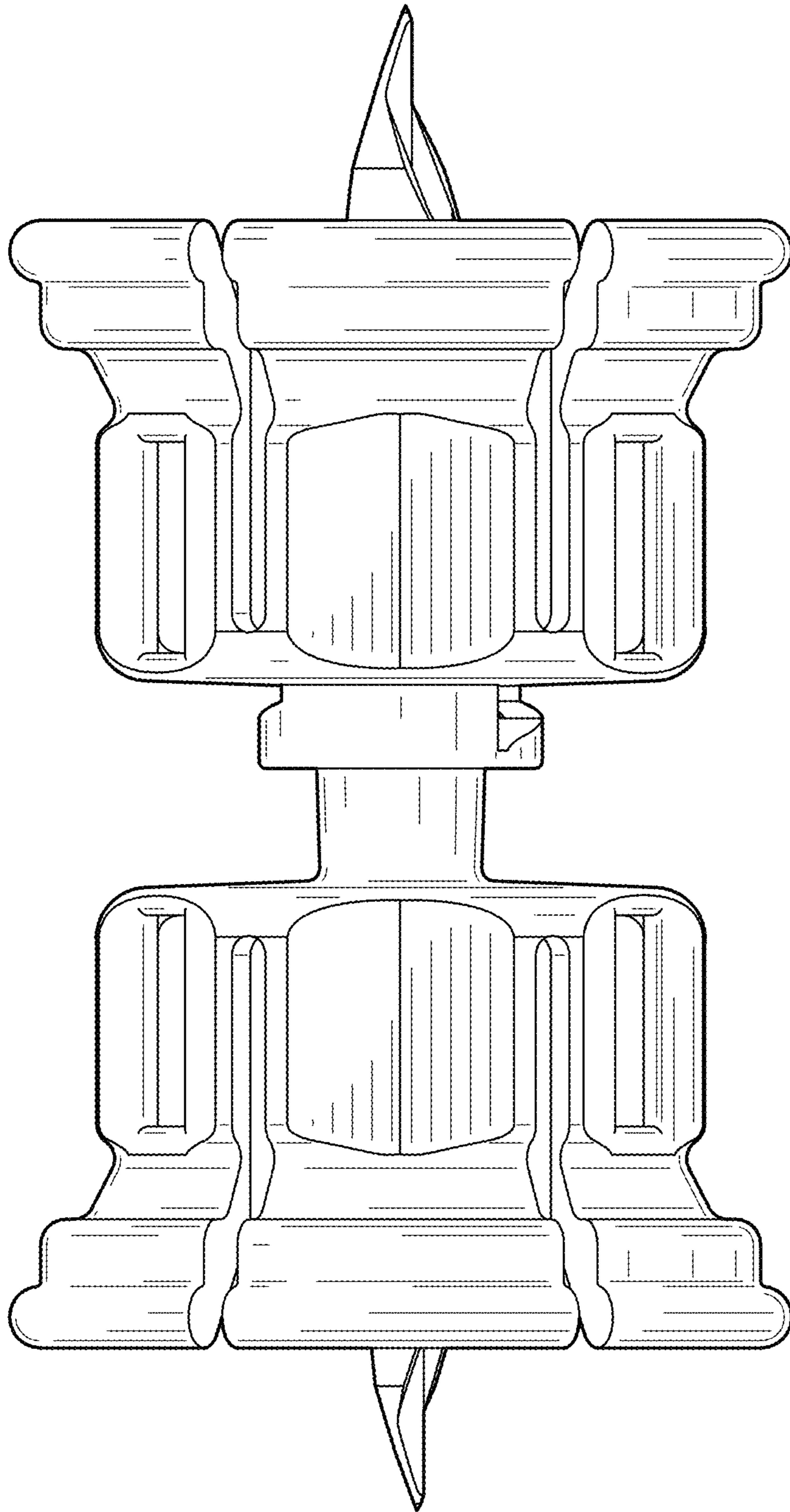

FIG. 5

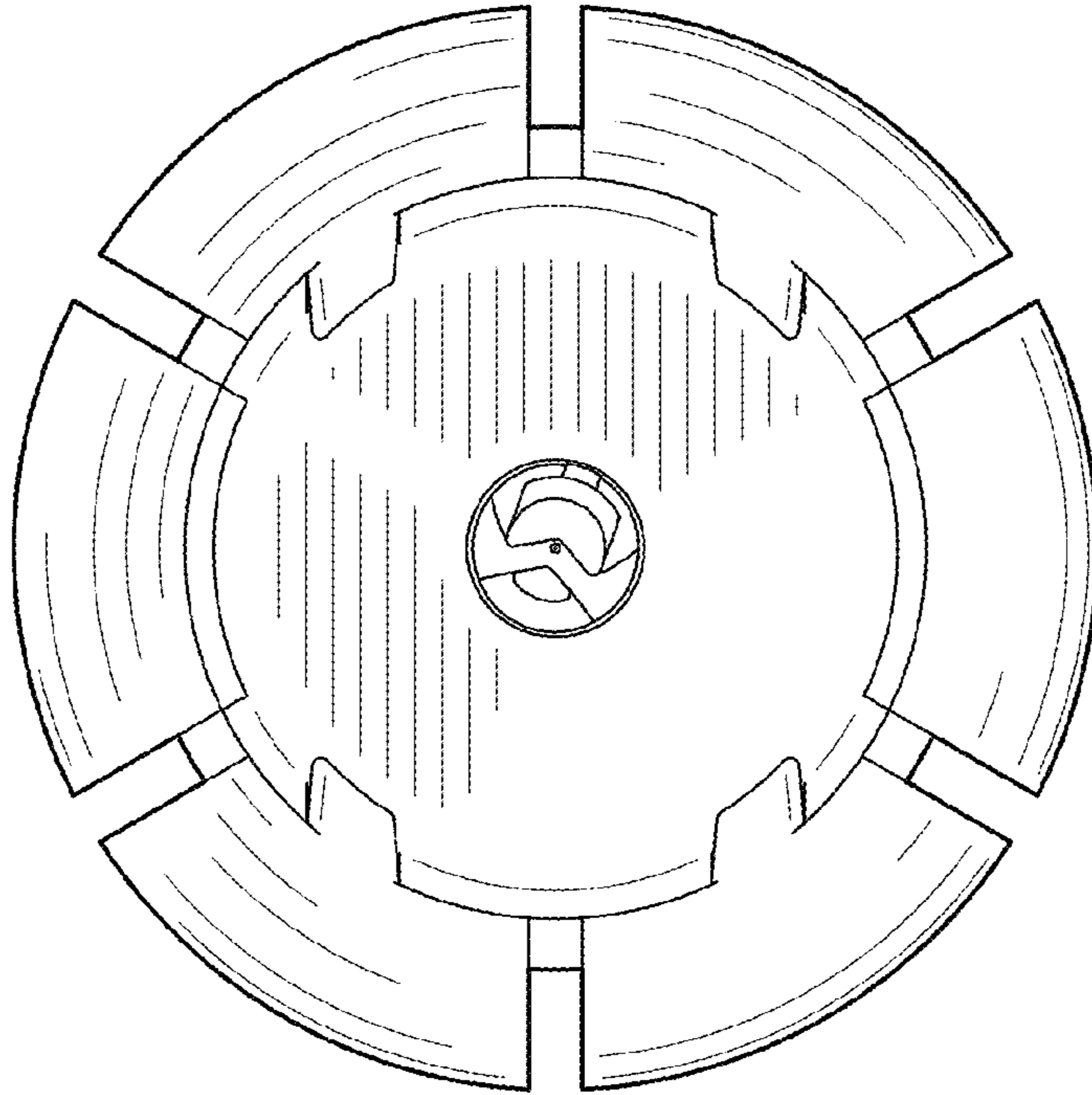

FIG. 6

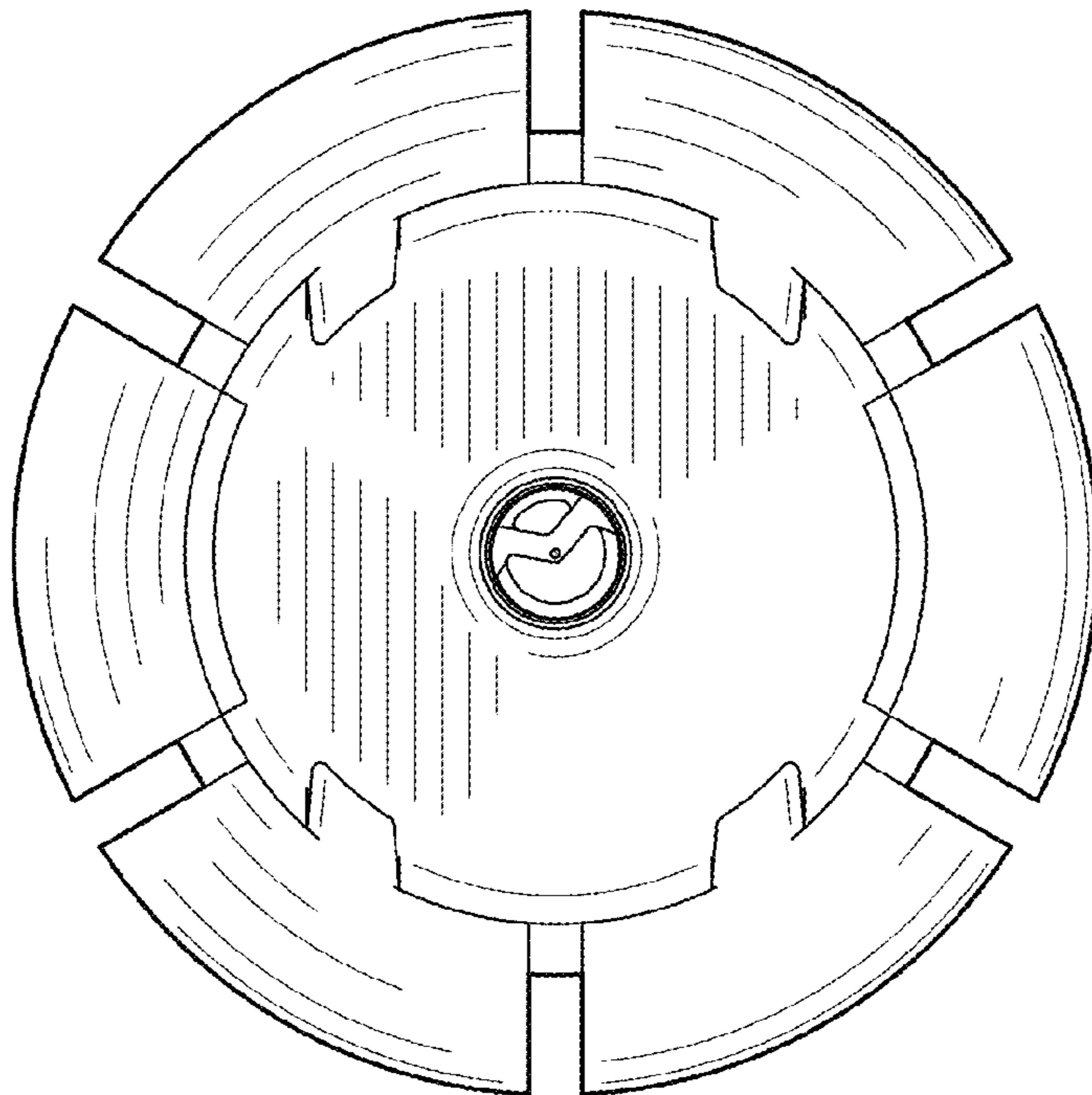

FIG. 7