



US00D757846S

(12) **United States Design Patent**
Mori

(10) **Patent No.:** **US D757,846 S**
(45) **Date of Patent:** **** May 31, 2016**

(54) **ANTIVIBRATION PEDESTAL FOR A MUSICAL INSTRUMENT**

(71) Applicant: **ROLAND CORPORATION**, Shizuoka (JP)

(72) Inventor: **Yoshiaki Mori**, Shizuoka (JP)

(73) Assignee: **ROLAND CORPORATION**, Shizuoka (JP)

(**) Term: **14 Years**

(21) Appl. No.: **29/471,010**

(22) Filed: **Oct. 28, 2013**

(51) **LOC (10) Cl.** **17-19**

(52) **U.S. Cl.**
USPC **D17/99**

(58) **Field of Classification Search**

USPC D17/4, 9, 13, 20, 99; D15/141; D8/354, D8/374; D6/708, 708.21, 708.22, 710, 567
CPC G10G 5/00; G12B 3/00; G12B 9/00; G12B 9/08; G10D 3/12; G10D 3/18; G10D 3/00; G10D 13/00; G10D 13/006; A47B 91/005; A47B 91/06; A47B 91/16; A47B 91/08; F16M 11/36; F16M 11/247; F16M 11/22; F16F 15/021; G10K 11/002
See application file for complete search history.

(56) **References Cited**

U.S. PATENT DOCUMENTS

1,534,440 A * 4/1925 Carter A47B 91/06
16/42 R
D111,901 S * 10/1938 Heller D17/9
3,213,963 A * 10/1965 Vogt E06C 7/46
182/111
D211,513 S * 6/1968 Brown D9/456
3,679,159 A * 7/1972 Bach F16F 9/0472
188/268
D242,073 S * 10/1976 Kasha D17/20
D278,155 S * 3/1985 Peavey et al. D17/20

(Continued)

FOREIGN PATENT DOCUMENTS

EP 0078649 A1 * 5/1983 G10K 11/002
WO WO 2014165828 A1 * 10/2014 F16M 11/041

Primary Examiner — Ian Simmons

Assistant Examiner — Ieisha Price

(74) *Attorney, Agent, or Firm* — Jianq Chyun IP Office

(57) **CLAIM**

The ornamental design for an antivibration pedestal for a musical instrument, as shown and described.

DESCRIPTION

FIG. 1 is a perspective view of first embodiment of a antivibration pedestal for a musical instrument showing a of my new design;

FIG. 2 is a front view of FIG. 1;

FIG. 3 is a rear view of FIG. 1;

FIG. 4 is a left side view of FIG. 1, the right side view being a mirror image of the left side view;

FIG. 5 is a top view of FIG. 1, the bottom view being a mirror image of the top view;

FIG. 6 is a perspective view of the second embodiment of a antivibration pedestal for a musical instrument showing a of my new design;

FIG. 7 is a front view of FIG. 6;

FIG. 8 is a rear view of FIG. 6;

FIG. 9 is a left side view of FIG. 6;

FIG. 10 is a right side view of FIG. 6; and,

FIG. 11 is a top view of the second embodiment, the bottom view being a mirror image of the top view.

The evenly-dashed broken lines in the drawings illustrate the portions of the antivibration pedestal for a musical instrument and form no part of the claimed design. The dash-dot-dash broken line in the drawings define the bounds of the claim and the entire area located within form no part thereof.

1 Claim, 7 Drawing Sheets

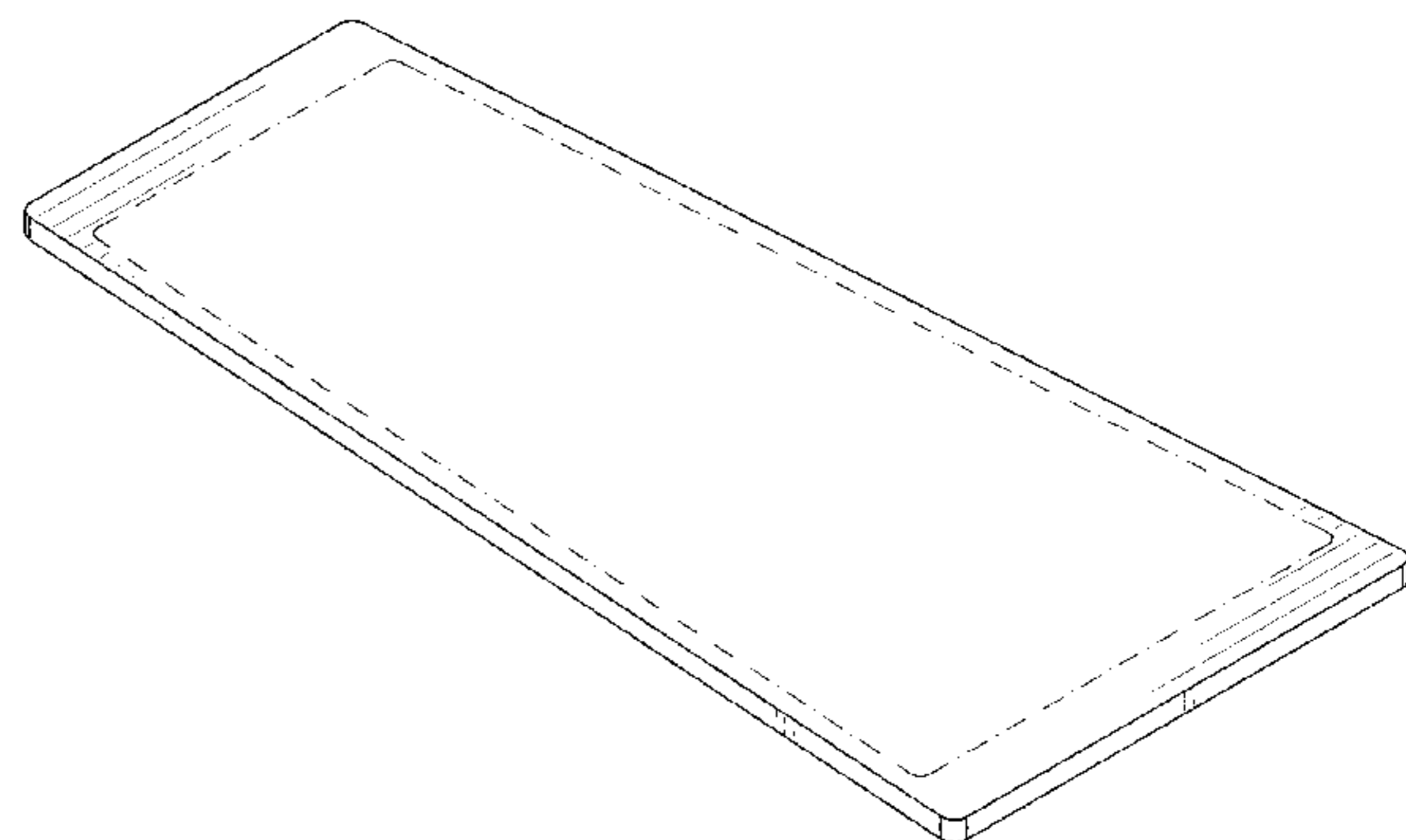
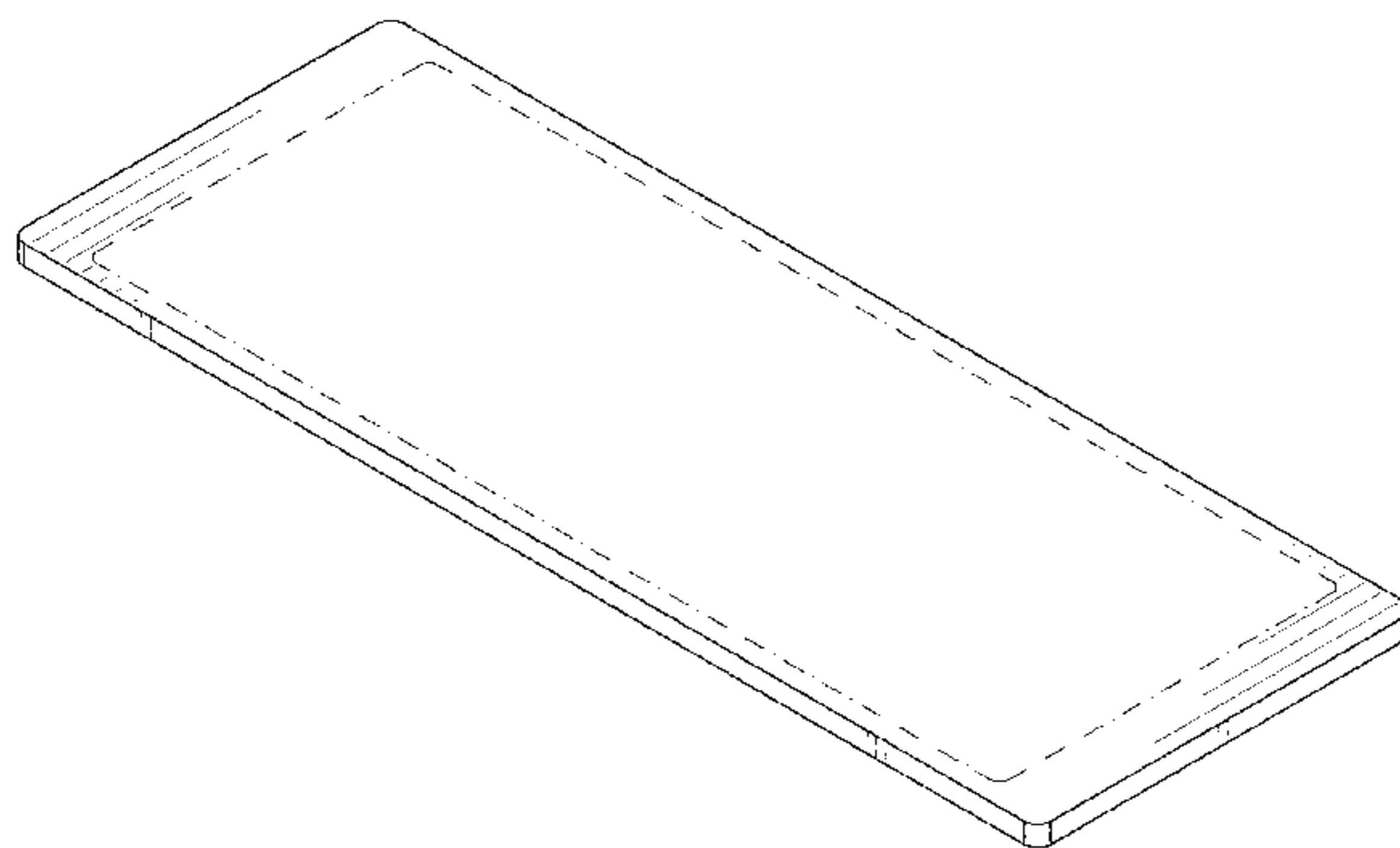

(56)

References Cited

U.S. PATENT DOCUMENTS

D310,953	S *	10/1990	Ilukowicz et al.	D8/354	2005/0156090	A1 *	7/2005	Drayton	248/346.03
5,883,315	A *	3/1999	Kaplan et al.	84/279	2006/0054767	A1 *	3/2006	Kemeny	A47B 91/005 248/346.01
D418,375	S *	1/2000	Goodman	D7/624.1	2007/0235605	A1 *	10/2007	Voelz	248/188.8
6,812,390	B2 *	11/2004	Kalbas	84/327	2007/0290104	A1 *	12/2007	Denison	F16M 11/20 248/188.8
D504,249	S *	4/2005	Wagner	D6/403	2009/0237591	A1 *	9/2009	Nishida	F16M 13/00 349/60
D505,564	S *	5/2005	Wagner	D6/403	2011/0304519	A1 *	12/2011	Klein	F16M 11/126 343/890
7,743,882	B2 *	6/2010	Vu	F16F 15/08 181/207	2012/0097829	A1 *	4/2012	Yoneda	F16F 15/021 248/636
D680,564	S *	4/2013	Snyder	D15/141	2013/0086790	A1 *	4/2013	Hyams	29/428
D685,255	S *	7/2013	Rocquet	D8/374	2013/0133504	A1 *	5/2013	Takegawa	84/421
D722,107	S *	2/2015	Magnusson	D17/20	2015/0115127	A1 *	4/2015	Mori	F16F 15/021 248/632
D728,673	S *	5/2015	Magnusson	D17/20						
D735,510	S *	8/2015	Volz	D6/708						
2005/0061138	A1 *	3/2005	Justis	84/421						

* cited by examiner

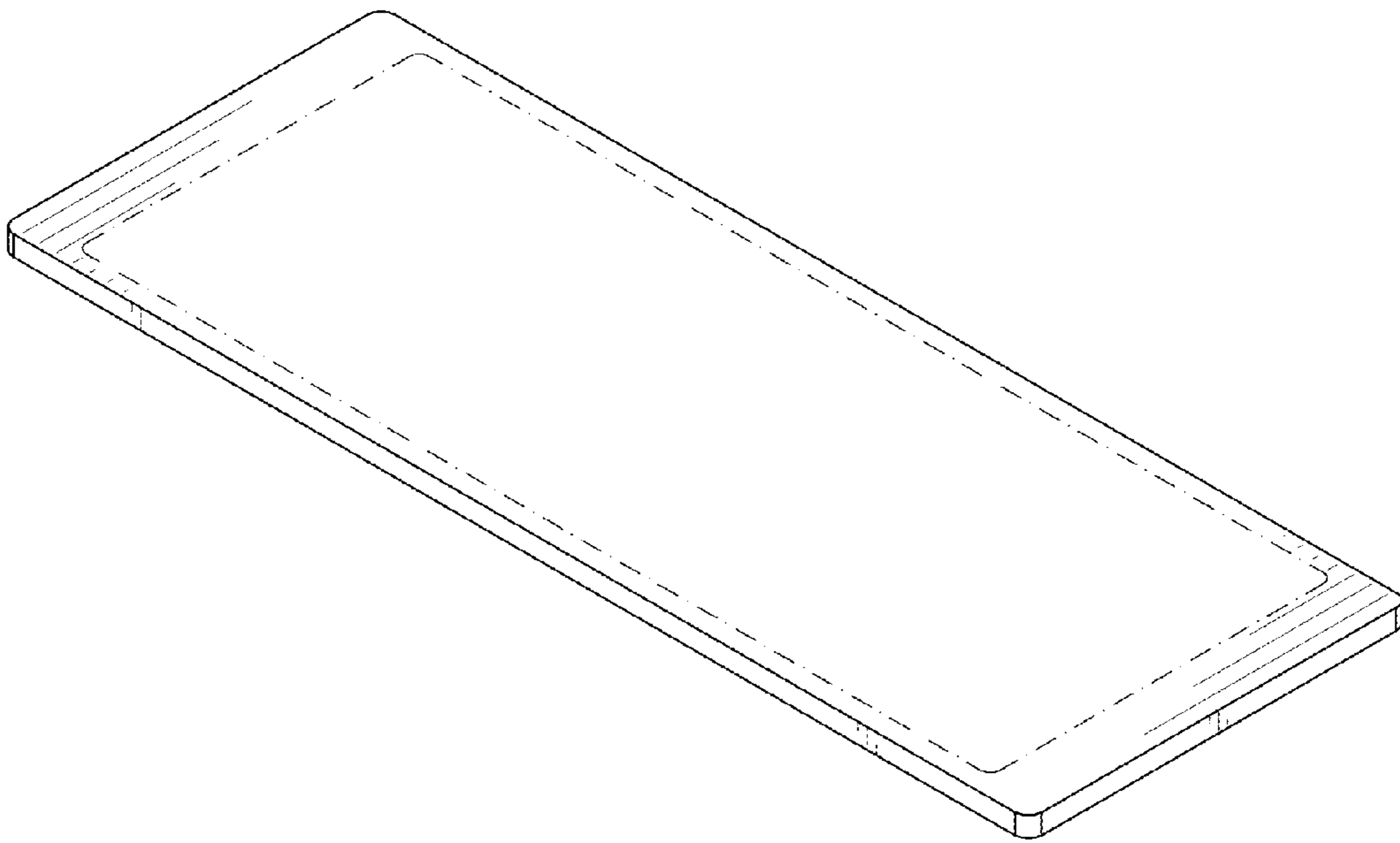

FIG. 1



FIG. 2

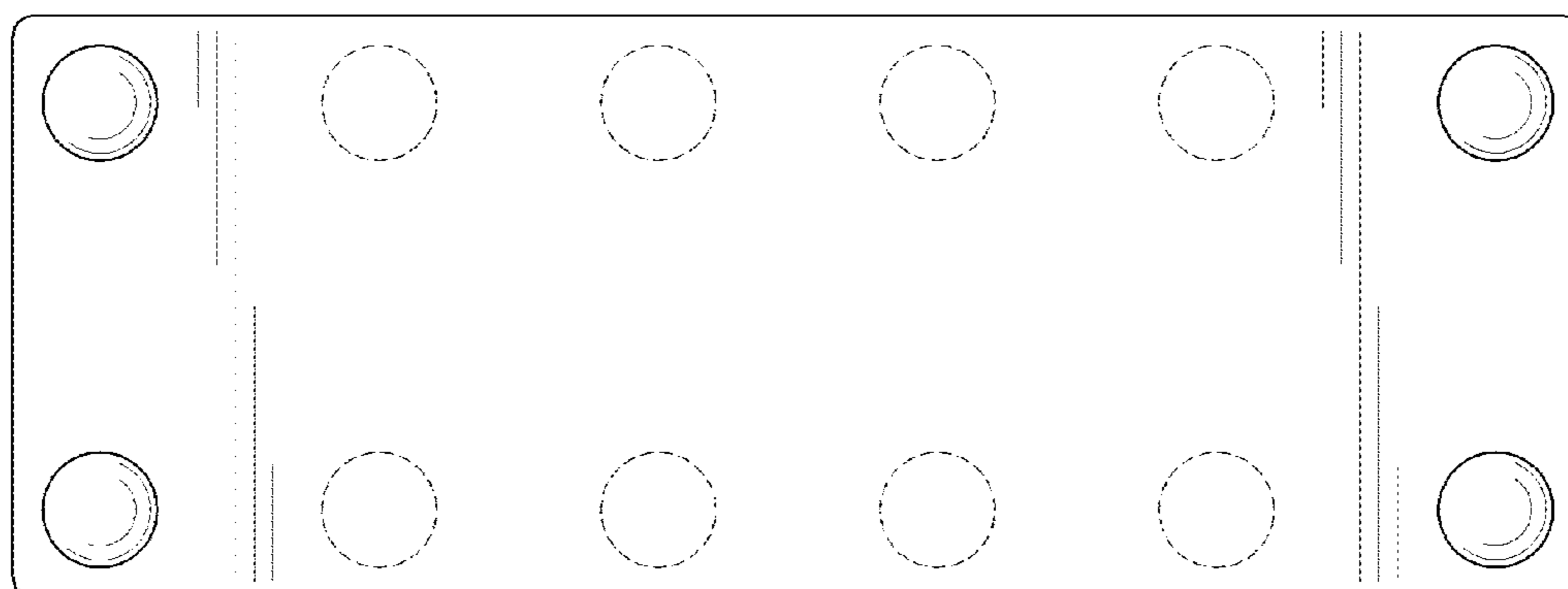

FIG. 3



FIG. 4

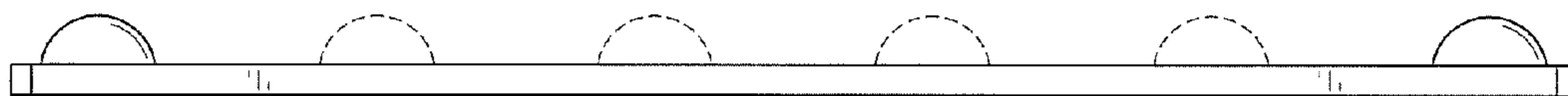

FIG. 5

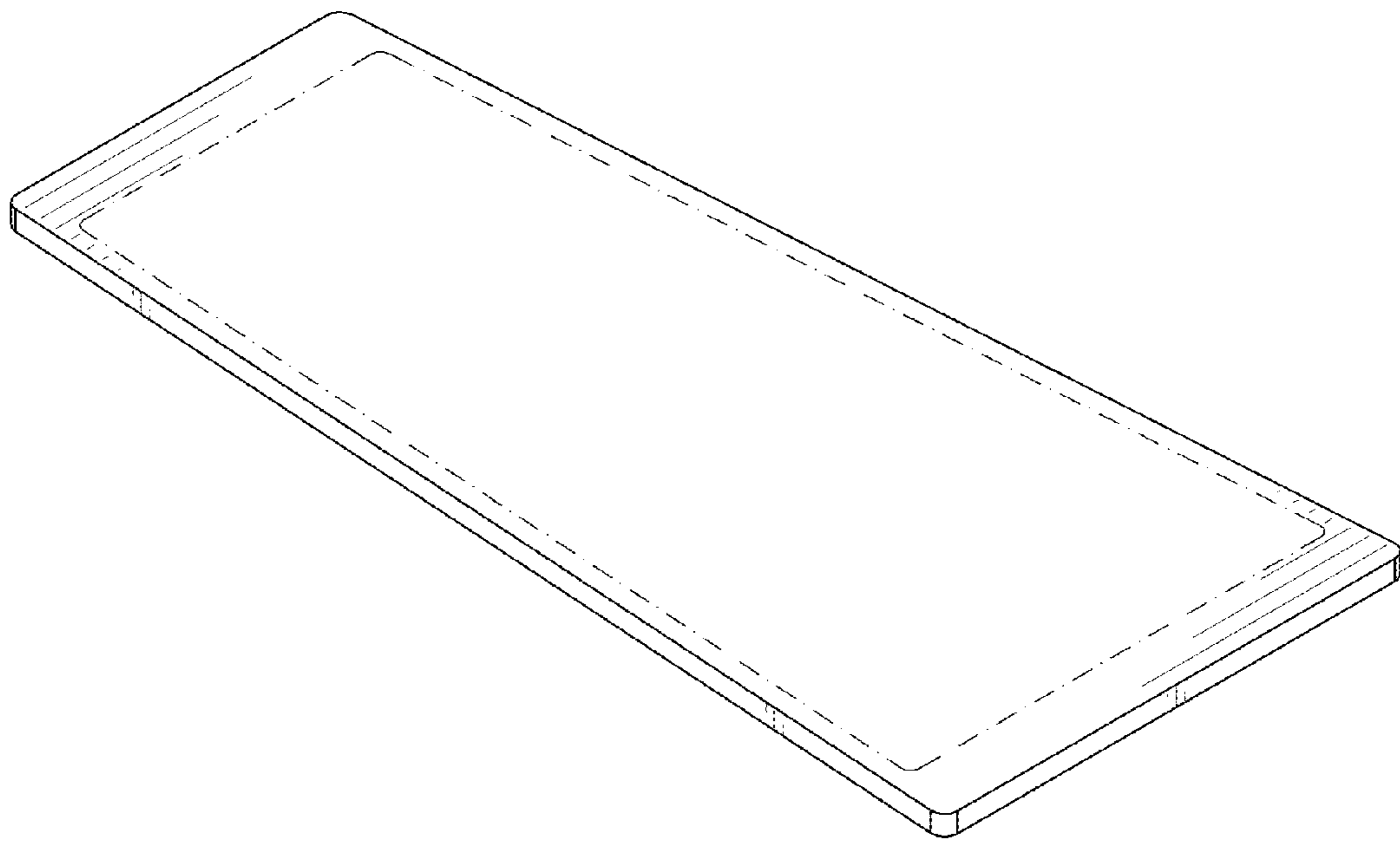

FIG. 6

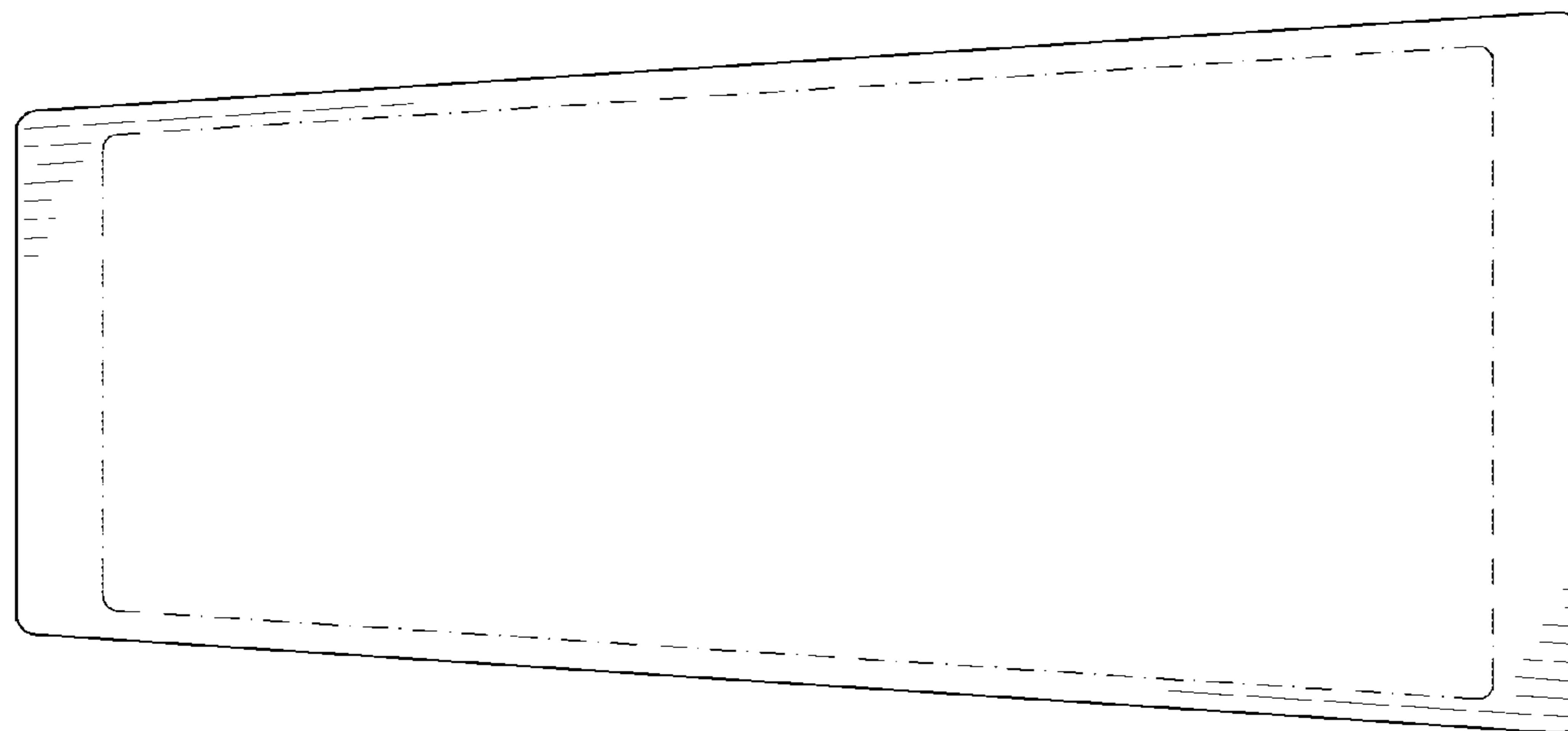

FIG. 7

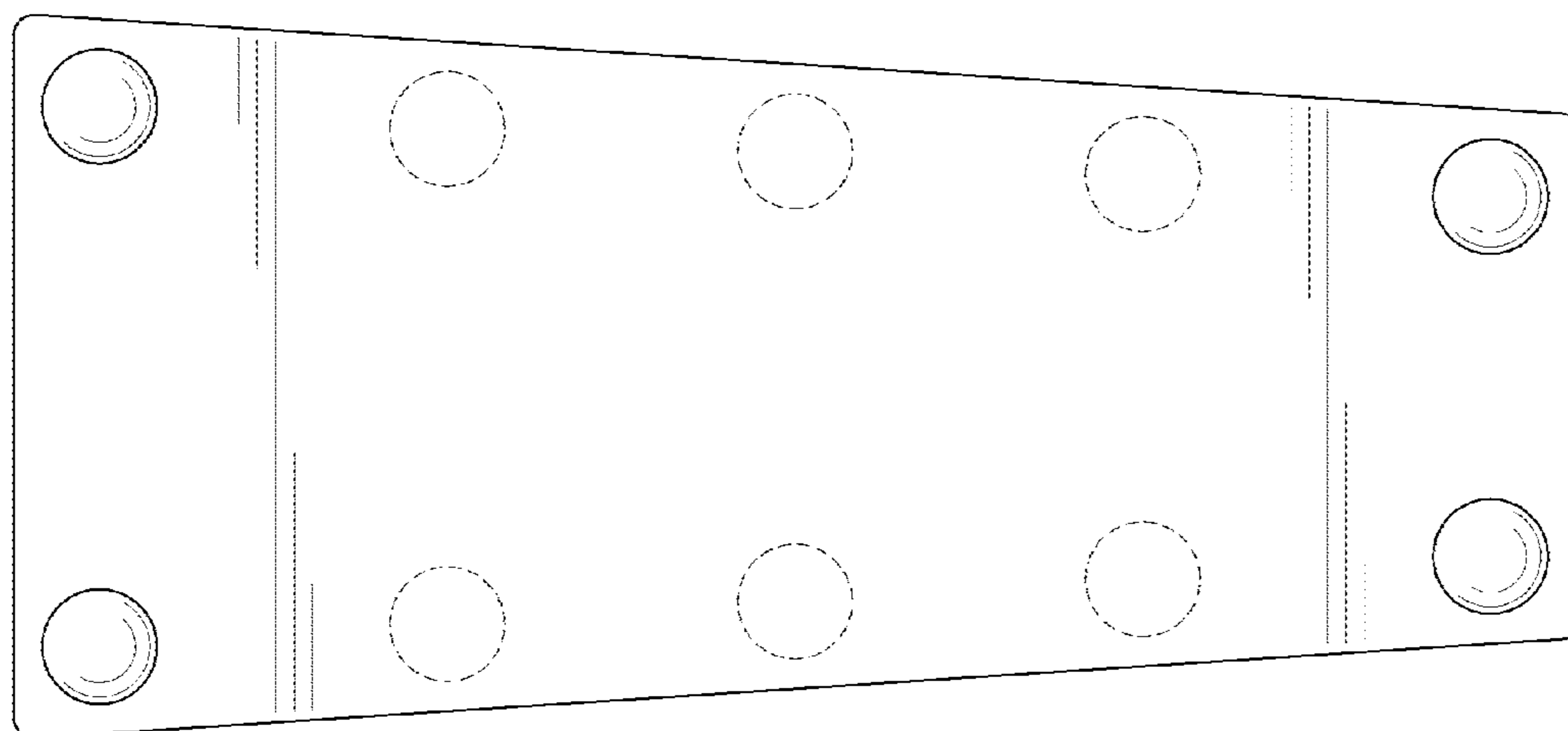

FIG. 8

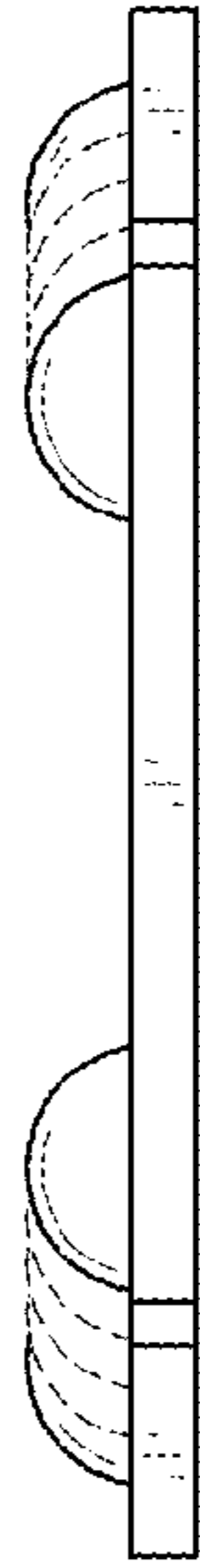

FIG. 9

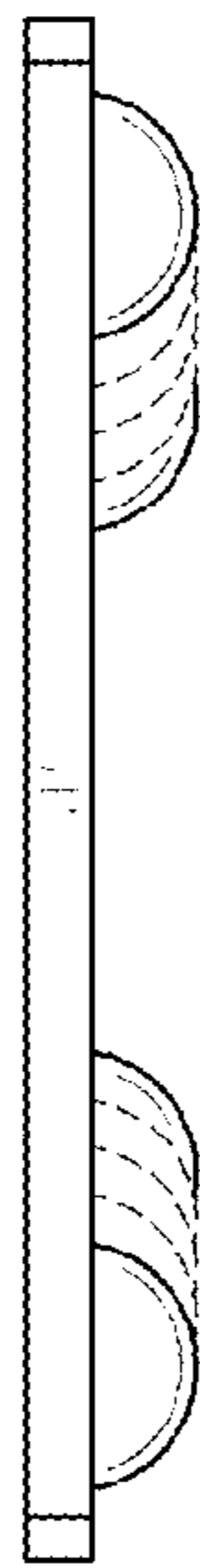

FIG. 10



FIG. 11