



US00D757612S

(12) **United States Design Patent**
Woller

(10) **Patent No.:** **US D757,612 S**
(45) **Date of Patent:** **** May 31, 2016**

(54) **MULTIPLE PLATFORM ADJUSTABLE
CARGO CARRIER**

(71) Applicant: **Ronald Ray Woller**, Decatur, AL (US)

(72) Inventor: **Ronald Ray Woller**, Decatur, AL (US)

(73) Assignee: **VIKING SOLUTIONS, LLC**, Decatur,
AL (US)

(**) Term: **14 Years**

(21) Appl. No.: **29/474,698**

(22) Filed: **Jan. 5, 2015**

(51) **LOC (10) Cl.** **12-10**

(52) **U.S. Cl.**
USPC **D12/106**

(58) **Field of Classification Search**
USPC D12/401-414; D6/610-611
CPC B60R 9/00-9/08; B60R 9/042; B60R 9/12
See application file for complete search history.

(56) **References Cited**

U.S. PATENT DOCUMENTS

4,169,581	A *	10/1979	Thurmond, Jr.	B66F 3/14 254/101
D279,661	S *	7/1985	Heard	D12/106
D340,790	S *	10/1993	Goodrich	D12/106
5,476,202	A	12/1995	Lipp	
D369,340	S *	4/1996	Lichtbach	D12/408
5,641,108	A	6/1997	Ewer	
5,775,560	A	7/1998	Zahn	
5,803,330	A	9/1998	Stack	
5,871,131	A	2/1999	Low	
D409,557	S *	5/1999	Armour	D12/408
6,062,451	A	5/2000	Lassanske	
D437,578	S *	2/2001	Stannard-Warne	D12/406
6,230,448	B1 *	5/2001	Oliver	E04G 23/0218 248/200.1
6,336,580	B1	1/2002	Allen	
6,382,487	B1	5/2002	Stein	

6,513,690	B1	2/2003	Churchill	
6,554,171	B1	4/2003	Ewing	
6,644,525	B1	11/2003	Allen	
D484,453	S *	12/2003	Harris	D12/406
6,769,584	B2	8/2004	Adams	
7,261,228	B2	8/2007	Prescott	
D586,287	S *	2/2009	McBride	D12/106
D630,558	S *	1/2011	Hopkins Clutterbuck ...	D12/106
D658,549	S *	5/2012	Neumann	D12/106
8,556,144	B2	10/2013	Liu	
8,622,267	B2	1/2014	Johnson	
8,800,831	B2	8/2014	Gray	
8,820,598	B2	9/2014	Tennyson	

* cited by examiner

Primary Examiner — Katrina A Betton

(57) **CLAIM**

The ornamental design for a multiple platform adjustable cargo carrier, as shown and described.

DESCRIPTION

FIG. 1 Top, right, front perspective view of the multiple platform adjustable cargo carrier;
 FIG. 2 Top, right, rear perspective view of the multiple platform adjustable cargo carrier;
 FIG. 3 Top plan view of the multiple platform adjustable cargo carrier of FIG. 1;
 FIG. 4 Bottom plan view of the multiple platform adjustable cargo carrier of FIG. 1;
 FIG. 5 Front elevation view of the multiple platform adjustable cargo carrier of FIG. 1;
 FIG. 6 Rear elevation view of the multiple platform adjustable cargo carrier of FIG. 1;
 FIG. 7 Right elevation view of the multiple platform adjustable cargo carrier of FIG. 1; and,
 FIG. 8 Left elevation view of the multiple platform adjustable cargo carrier of FIG. 1.
 Multiple platform adjustable cargo carrier for transportation of cargo on the rear receiver hitch of an automobile.

1 Claim, 8 Drawing Sheets

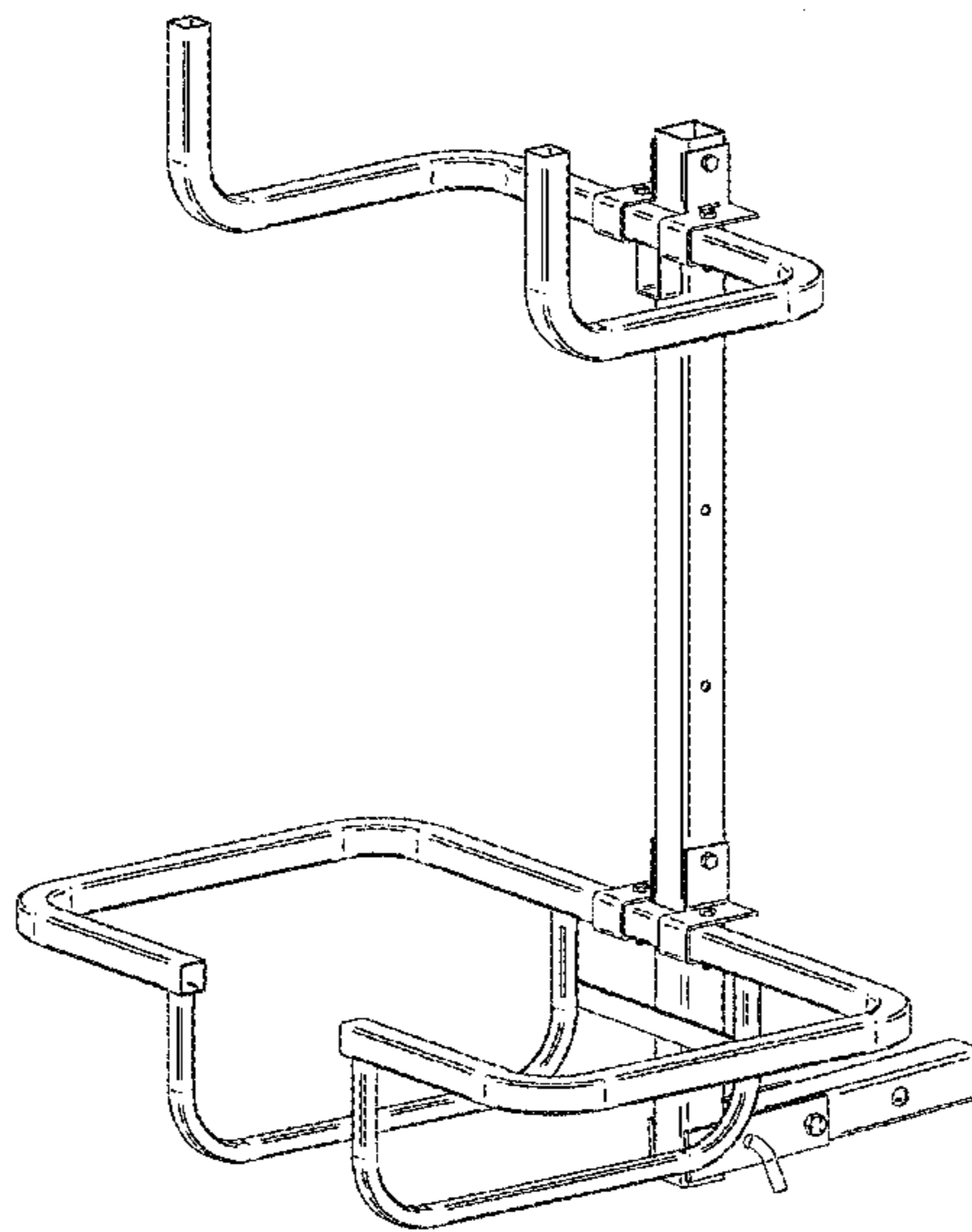

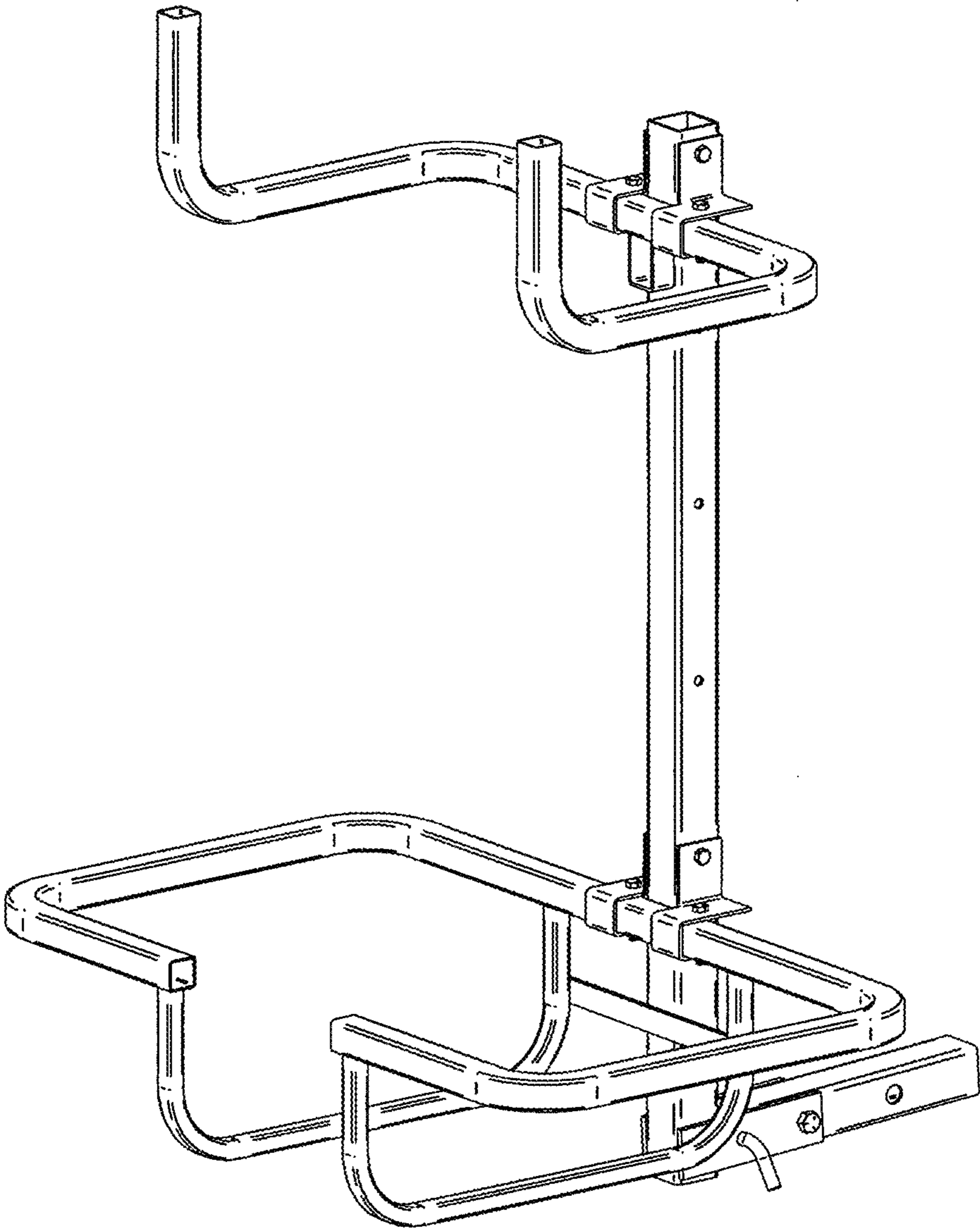

FIG. 1

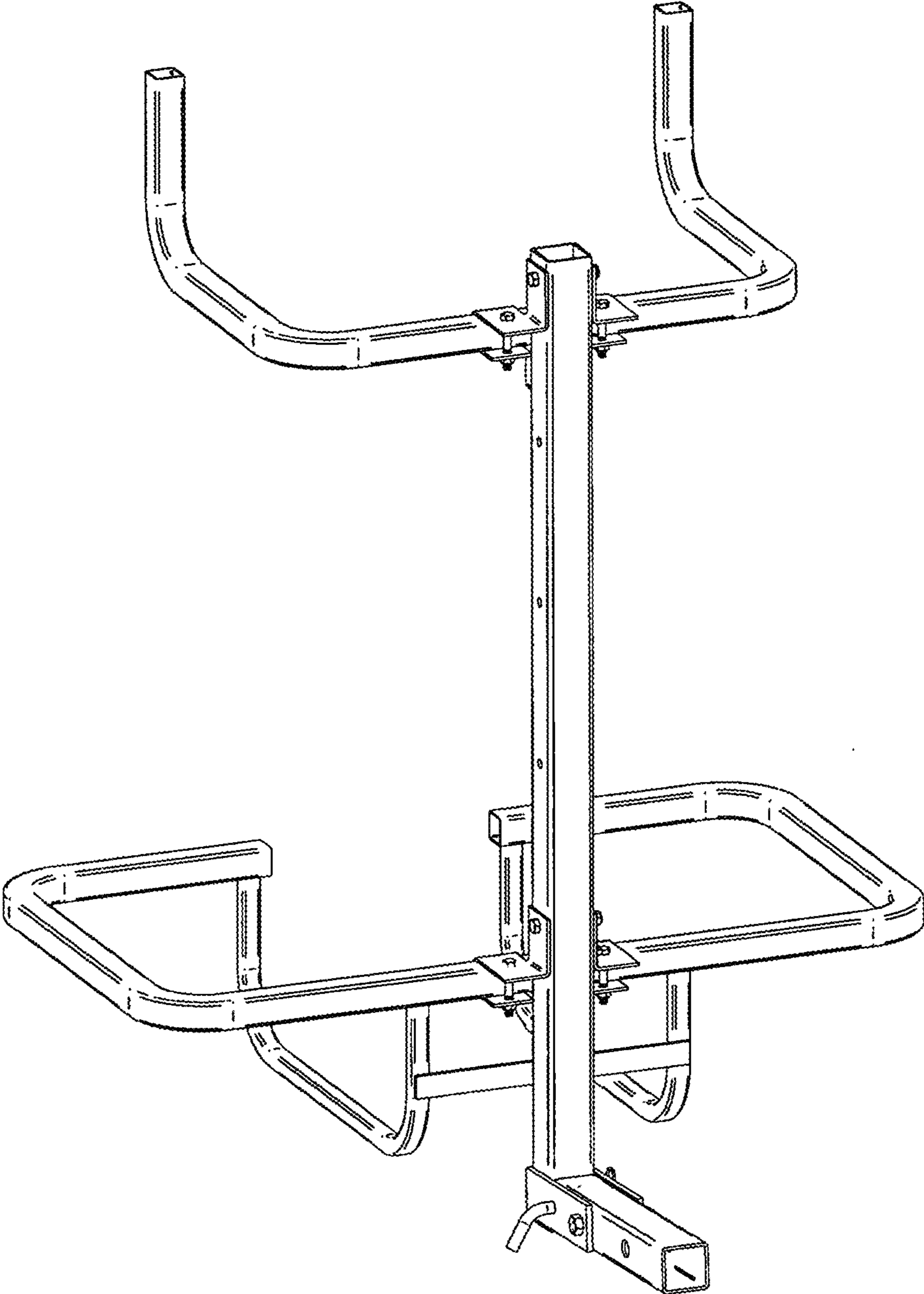

FIG. 2

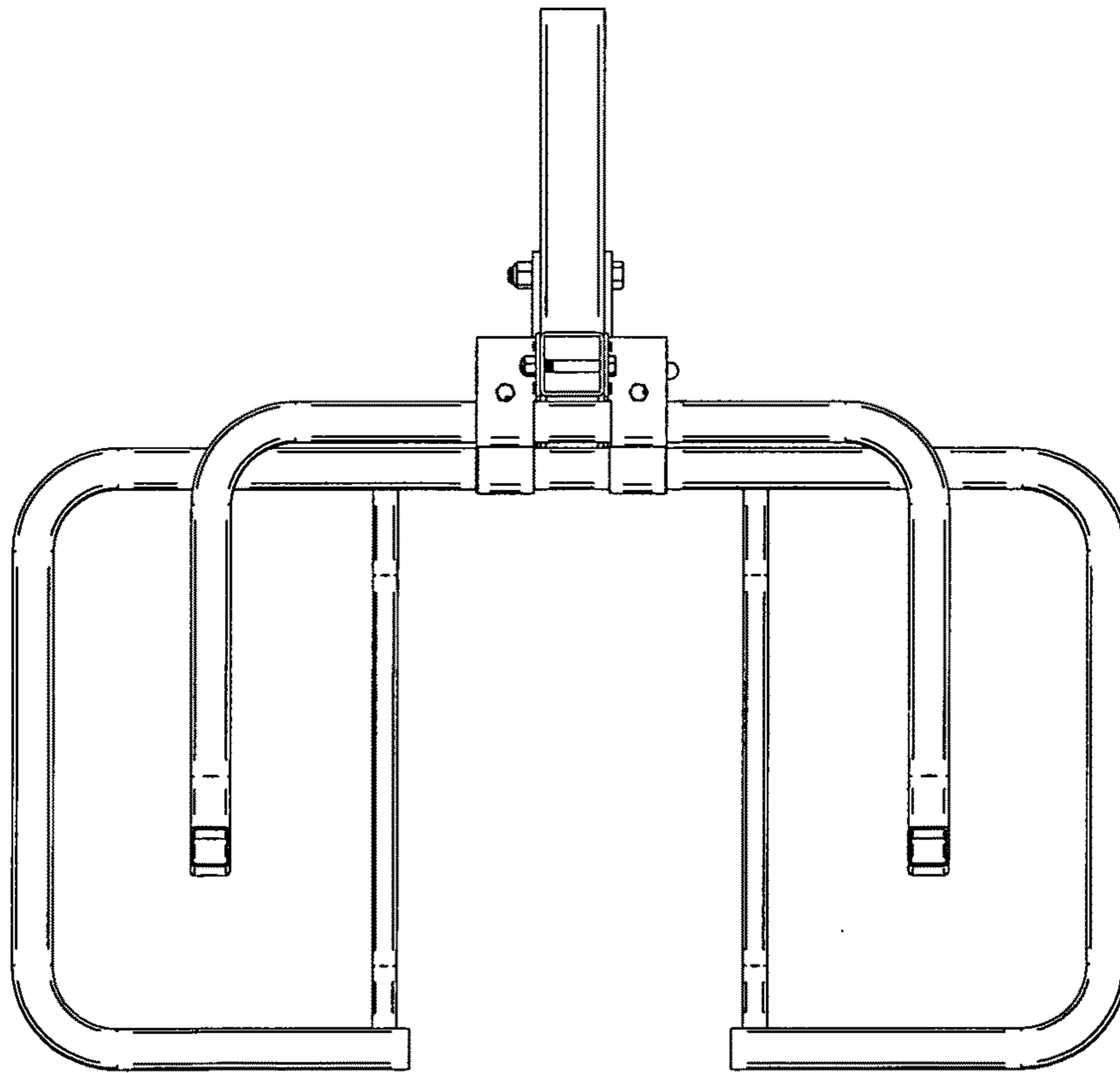

FIG. 3

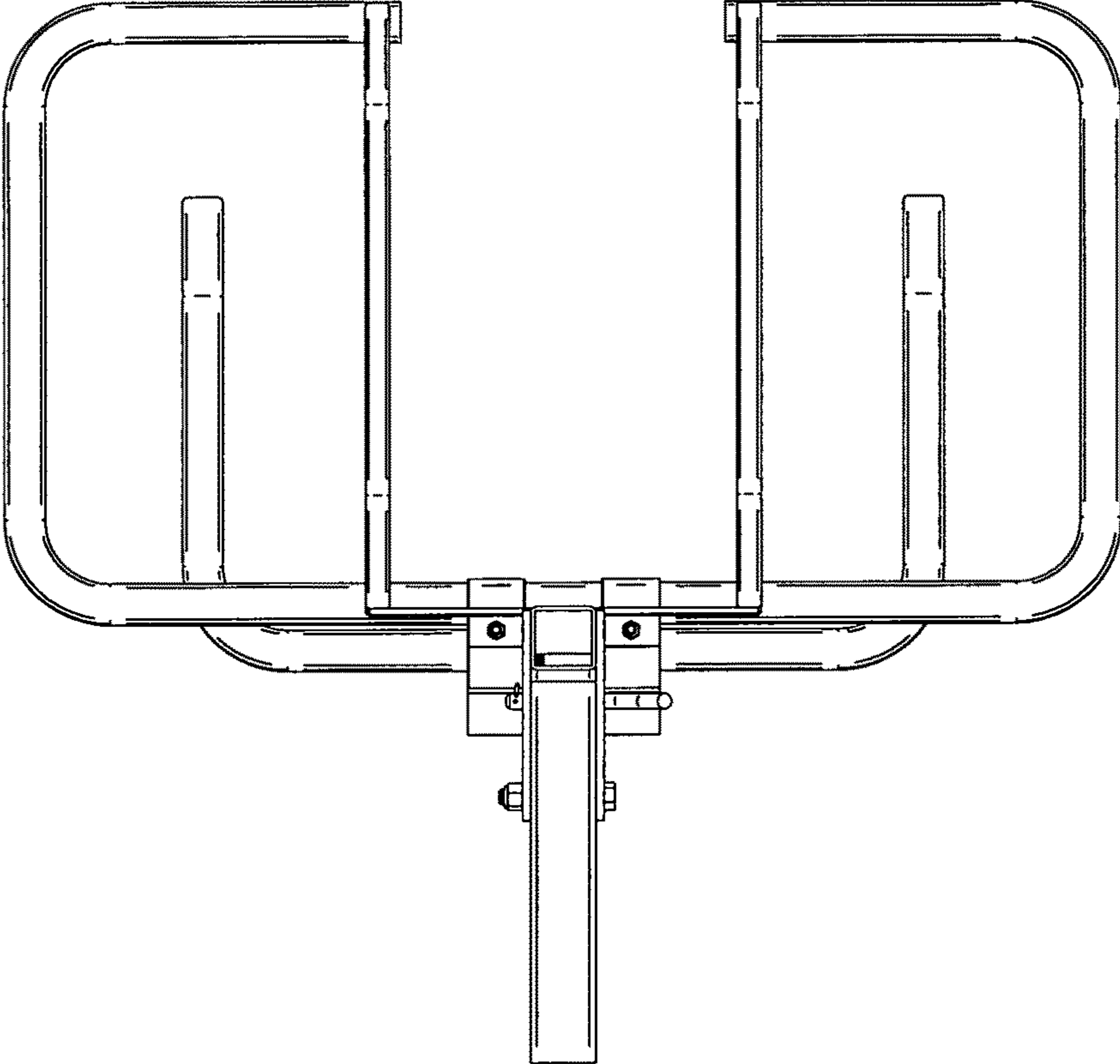

FIG. 4

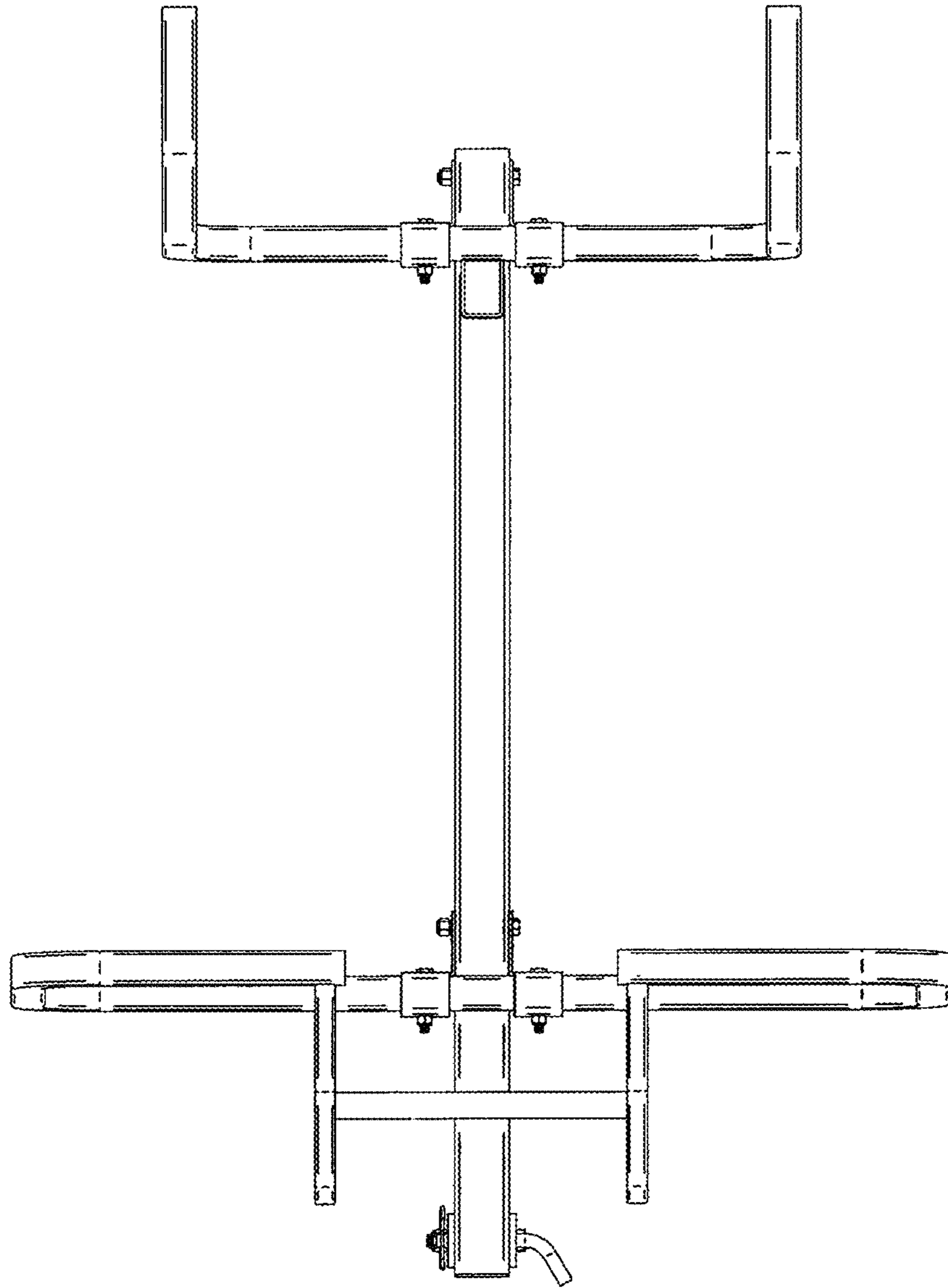

FIG. 5

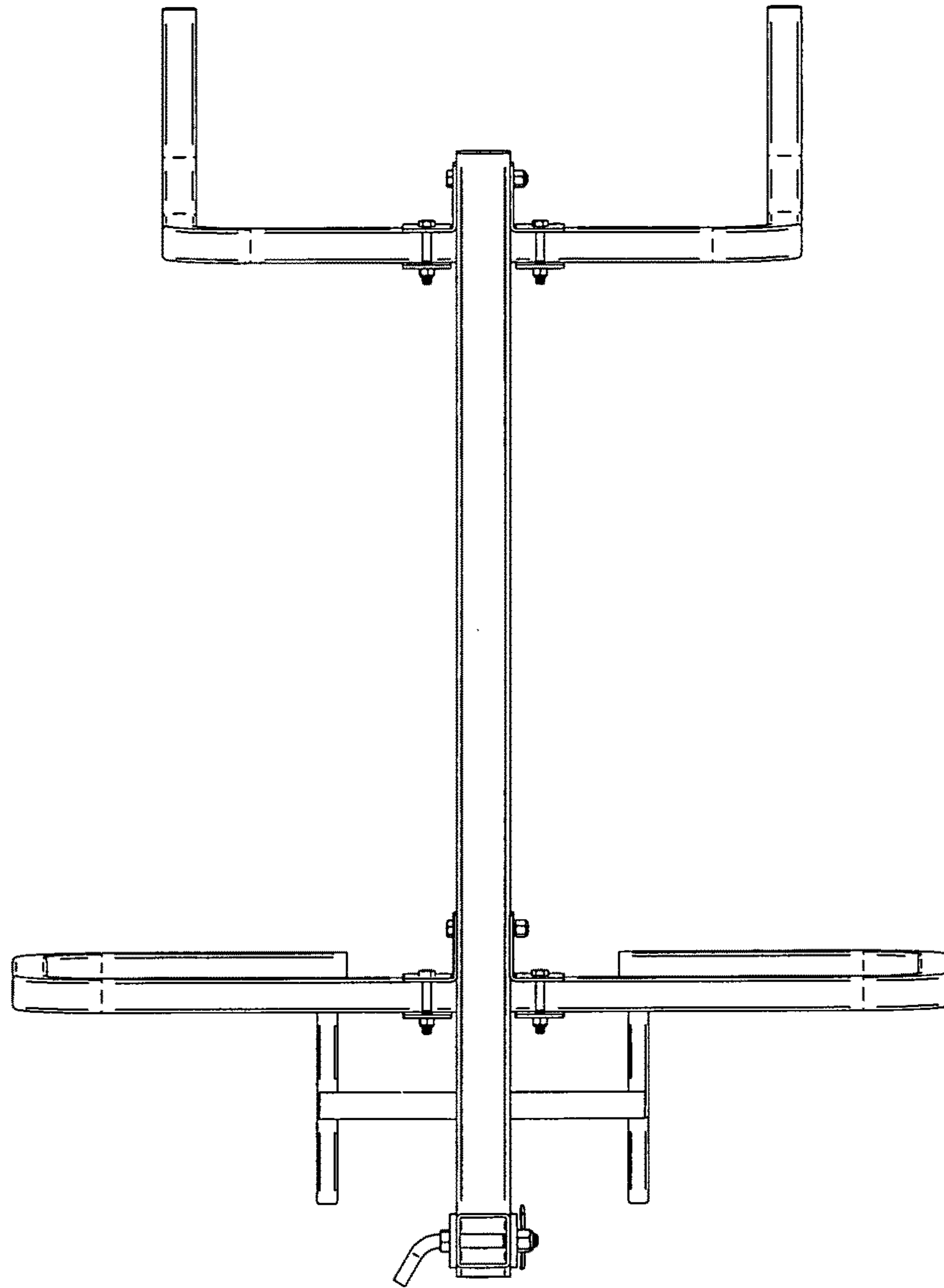

FIG. 6

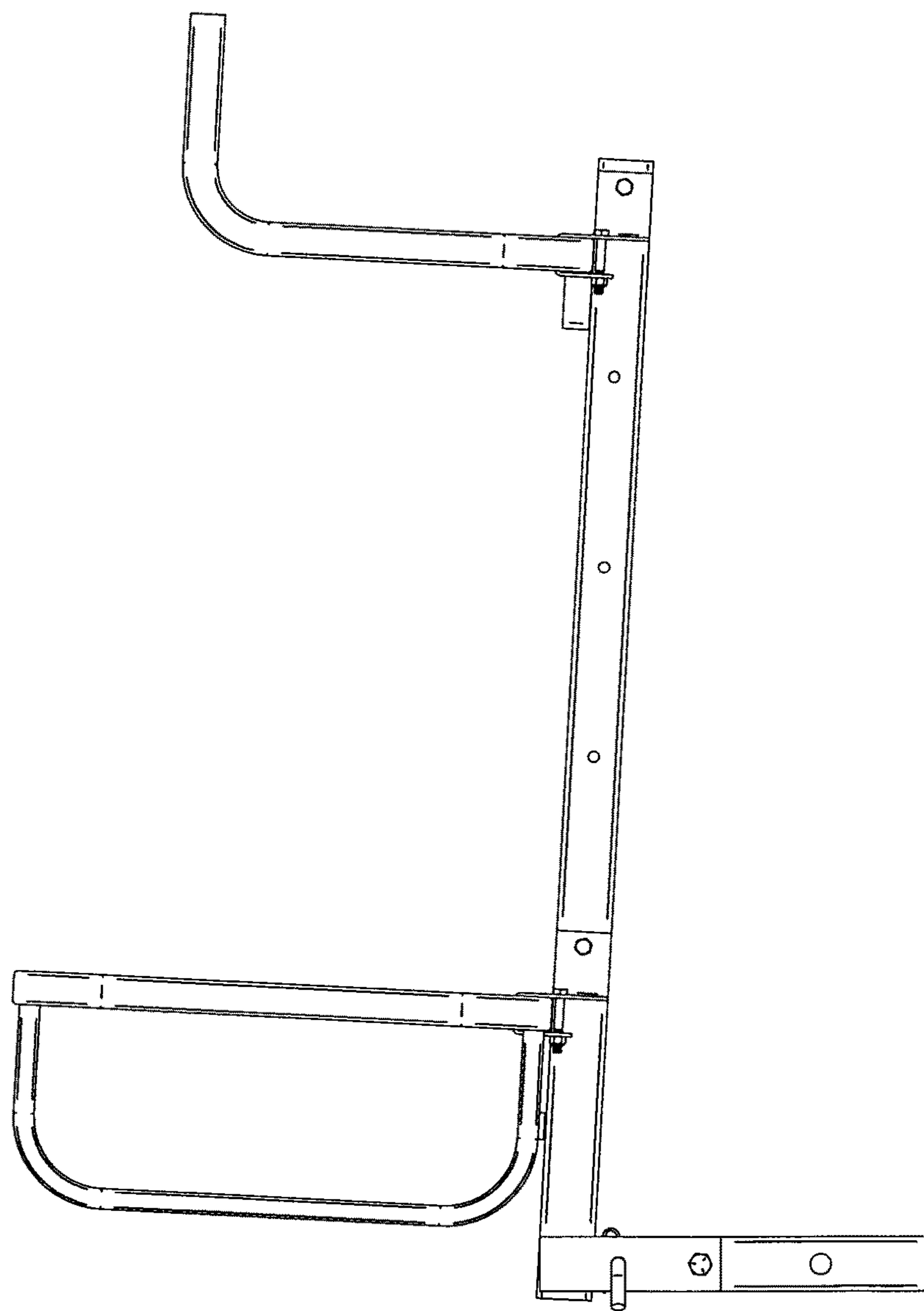

FIG. 7

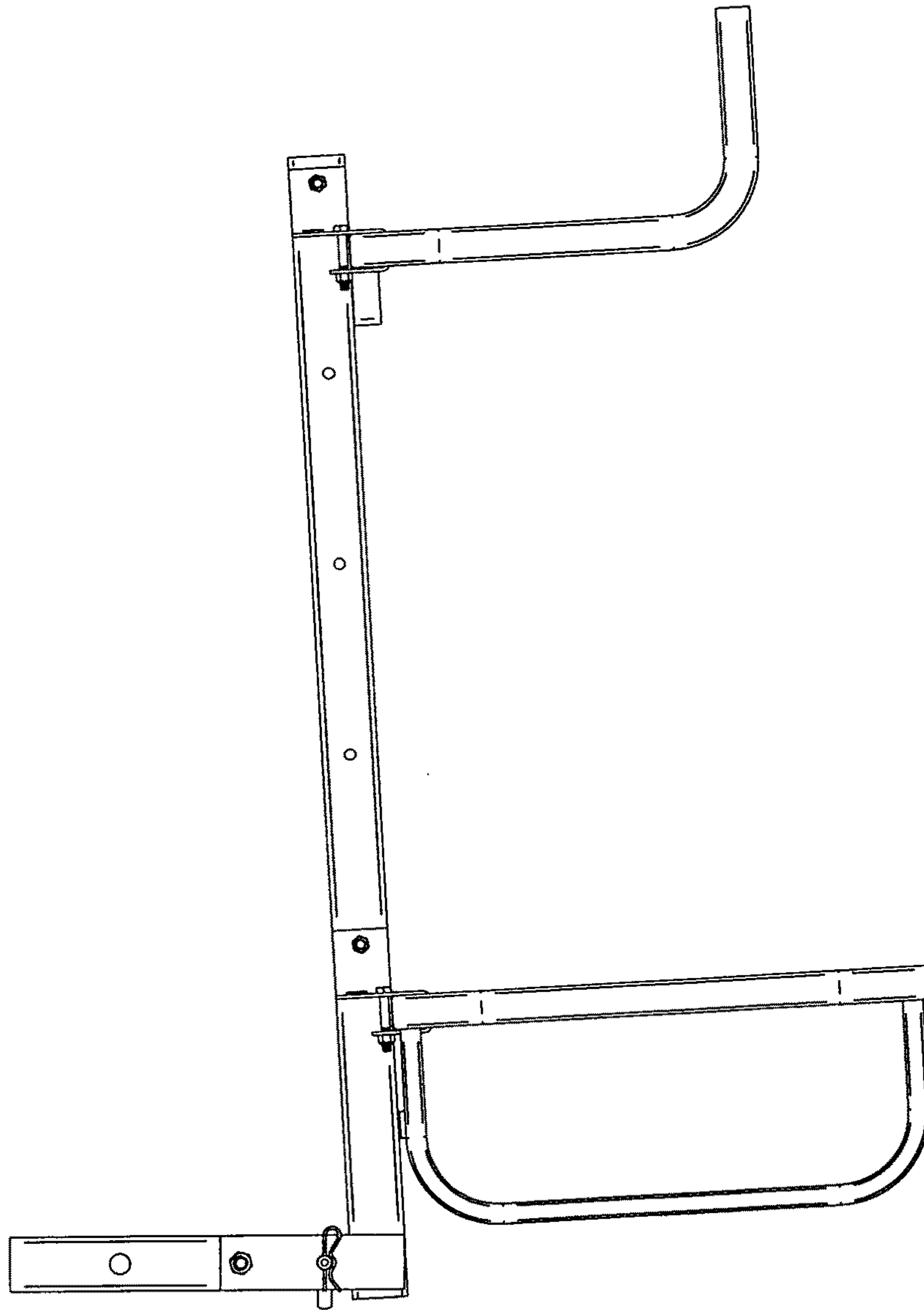

FIG. 8