



US00D757560S

(12) **United States Design Patent**  
**Venturini Fendi**

(10) **Patent No.:** **US D757,560 S**

(45) **Date of Patent:** **\*\* \*May 31, 2016**

(54) **PERFUME BOTTLE**

B65D 2501/0009; B65D 2501/0081; B65D  
11/0037

(71) Applicant: **Fendi Adele S.R.L.**, Rome (IT)

See application file for complete search history.

(72) Inventor: **Maria Silvia Venturini Fendi**, Rome (IT)

(56) **References Cited**

(73) Assignee: **FENDI ADELE S.R.L.**, Rome (IT)

U.S. PATENT DOCUMENTS

(\*) Notice: This patent is subject to a terminal disclaimer.

D453,106 S *	1/2002	Peltrault	.....	D9/687
D474,693 S *	5/2003	Gruosi-Scheufele	.....	D9/544
D542,670 S *	5/2007	Herrmann	.....	D9/560
D549,589 S *	8/2007	Lavigne	.....	D9/573
D580,778 S *	11/2008	Konckier	.....	D9/694
D656,830 S *	4/2012	Rodrigeuz	.....	D9/520
D666,500 S *	9/2012	Fendi	.....	D9/652

(\*\*) Term: **14 Years**

\* cited by examiner

(21) Appl. No.: **29/454,346**

(22) Filed: **May 9, 2013**

*Primary Examiner* — Ian Simmons

(30) **Foreign Application Priority Data**

Jan. 30, 2013 (WO) ..... DM/080 039

(74) *Attorney, Agent, or Firm* — Lucas & Mercanti, LLP

(51) **LOC (10) Cl.** ..... **09-01**

(52) **U.S. Cl.**  
USPC ..... **D9/573; D9/435; D9/444; D9/574**

(58) **Field of Classification Search**  
USPC ..... D9/434-435, 439, 444-445, 516, 544,  
D9/546, 572-574, 682, 686, 694, 715,  
D9/719; D7/300, 300.1, 316, 598;  
D28/91.1

CPC ..... B65D 1/00; B65D 1/02; B65D 1/0223;  
B65D 23/00; B65D 83/00; B65D 83/14;  
B65D 83/20; B65D 83/38; B65D 2501/00;

(57) **CLAIM**

The ornamental design for a perfume bottle, as shown and described.

**DESCRIPTION**

FIG. 1 is a perspective view of the perfume bottle;  
FIG. 2 is a front view thereof;  
FIG. 3 is a right side view thereof;  
FIG. 4 is a rear view thereof;  
FIG. 5 is a left side view thereof; and,  
FIG. 6 is a top view thereof.

**1 Claim, 2 Drawing Sheets**

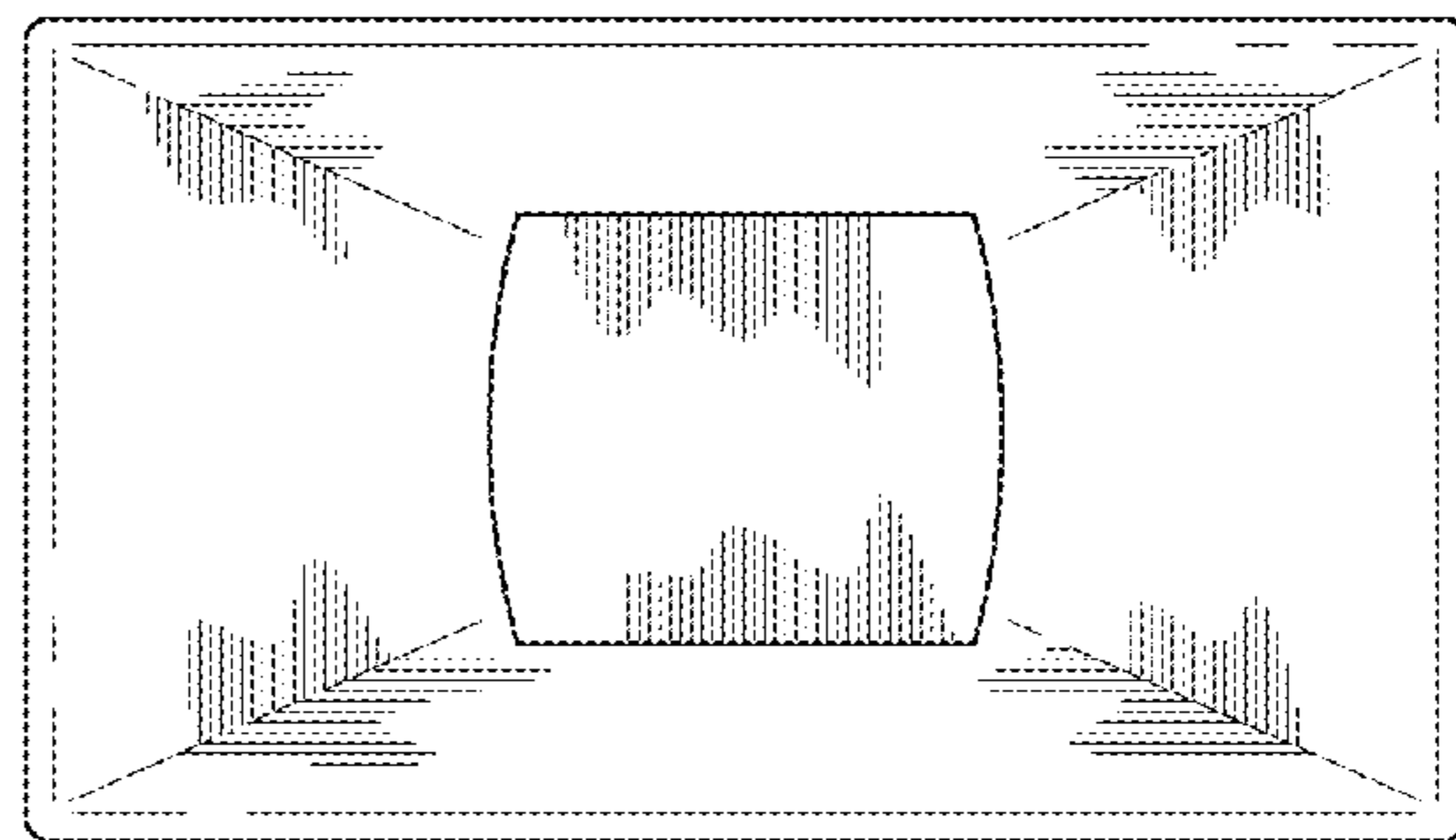
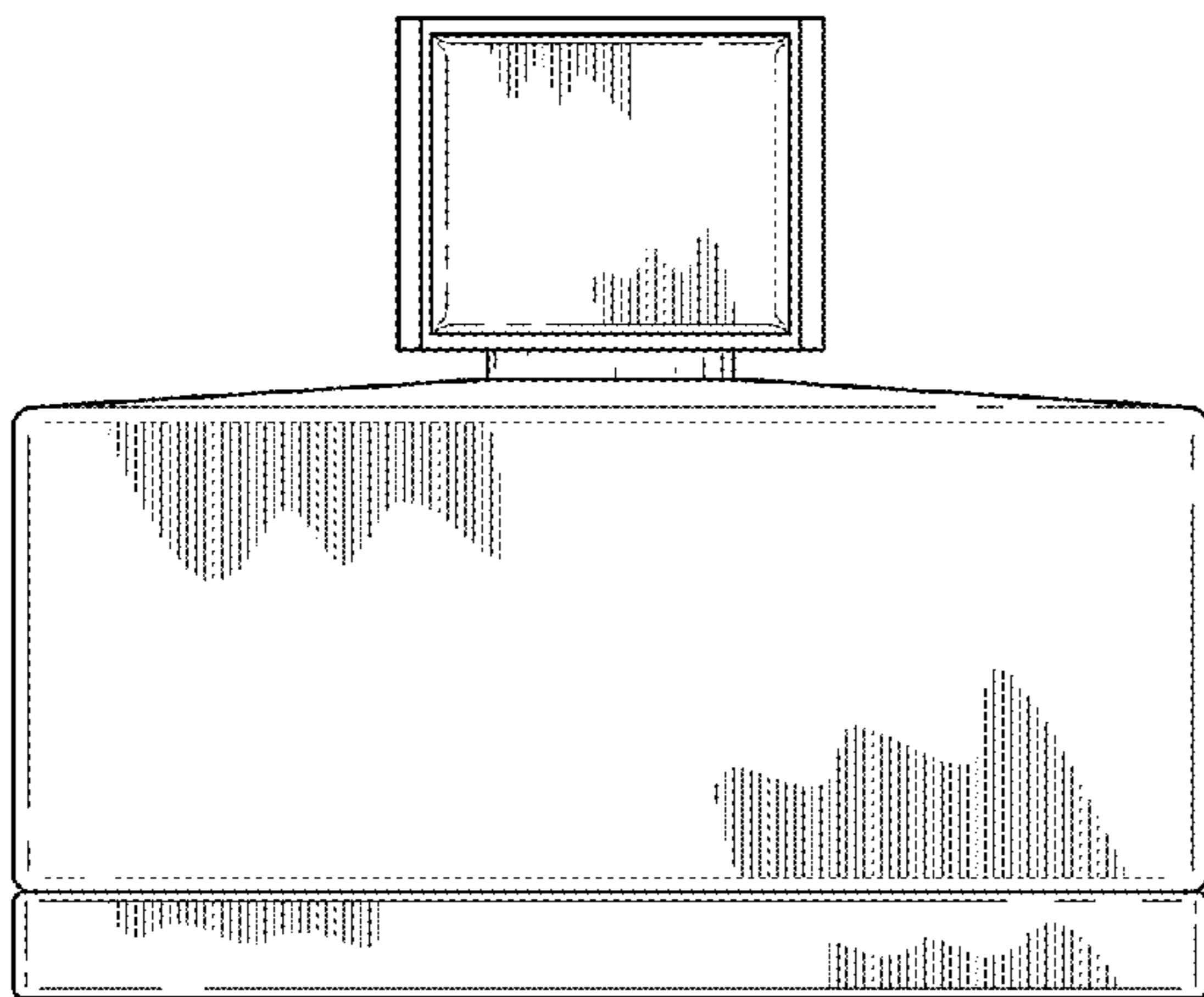

FIG. 1

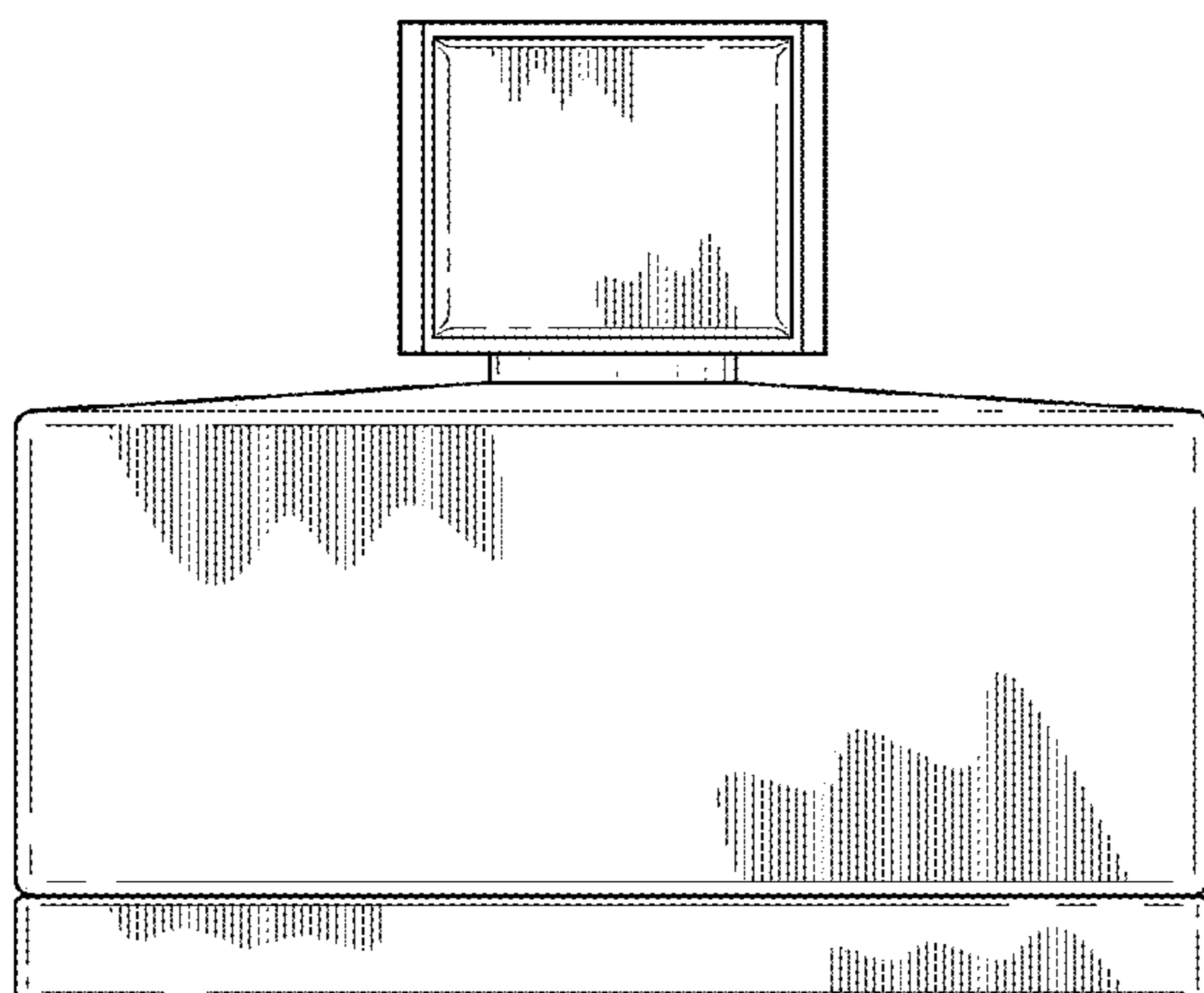
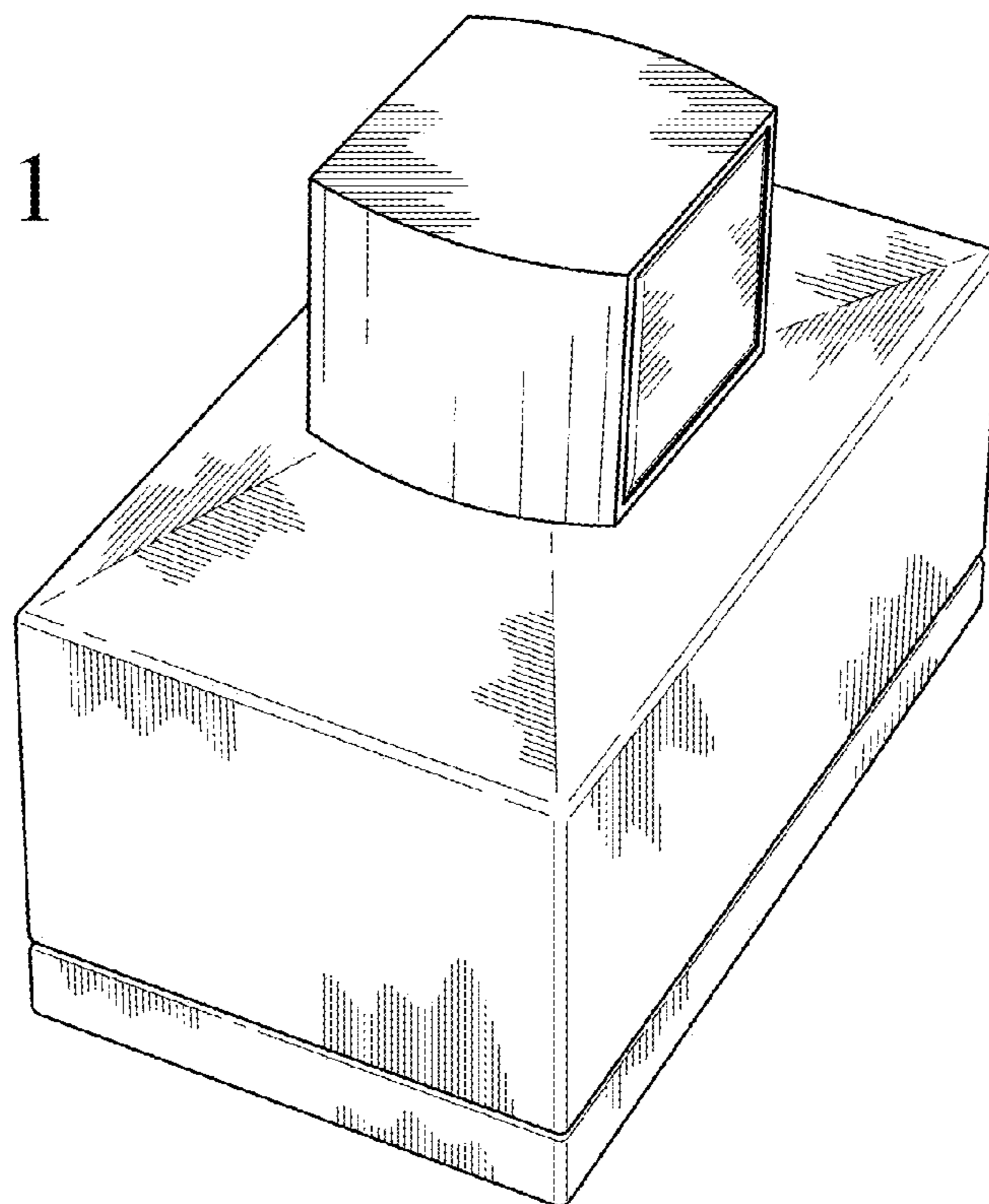

FIG. 2

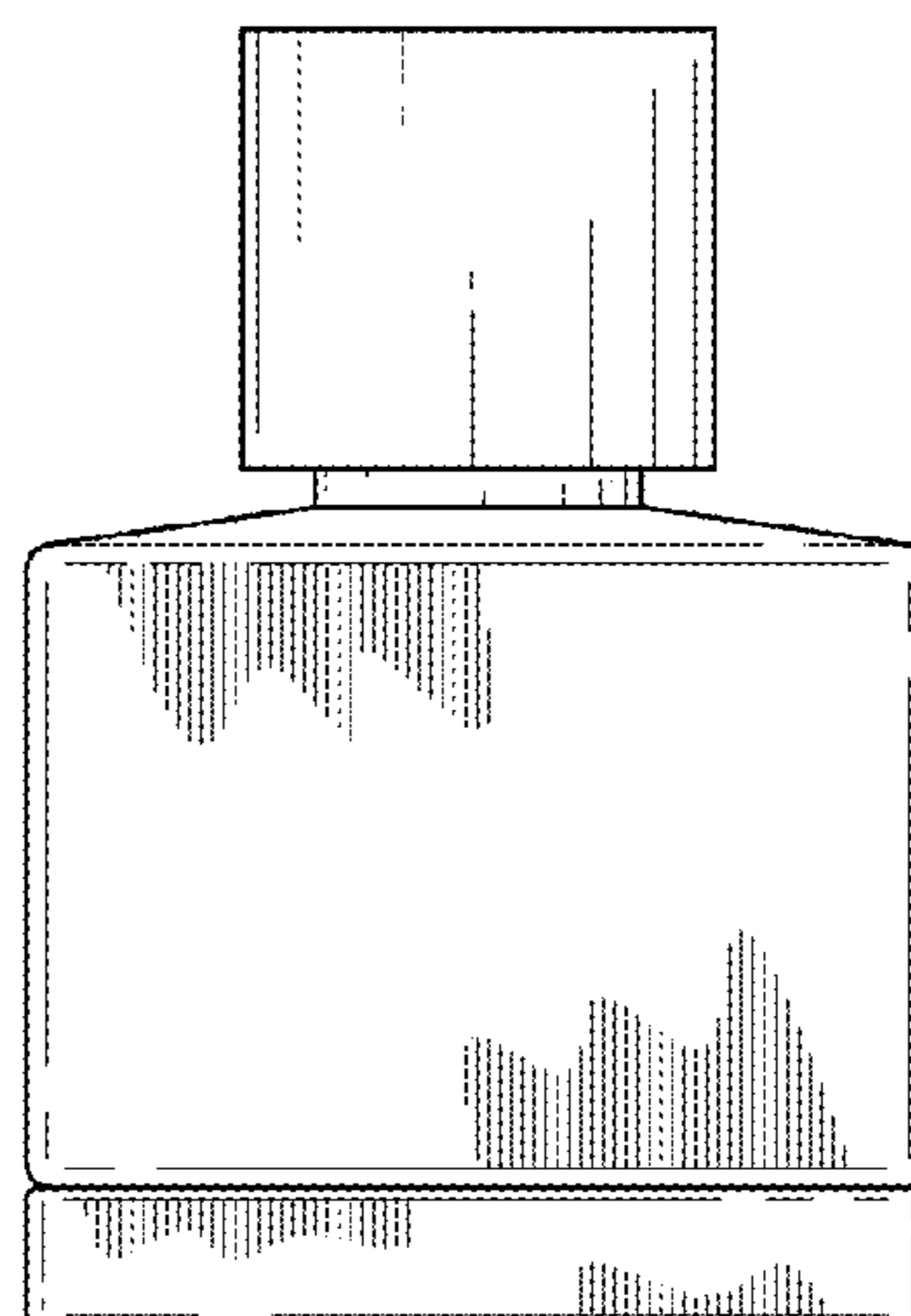

FIG. 3

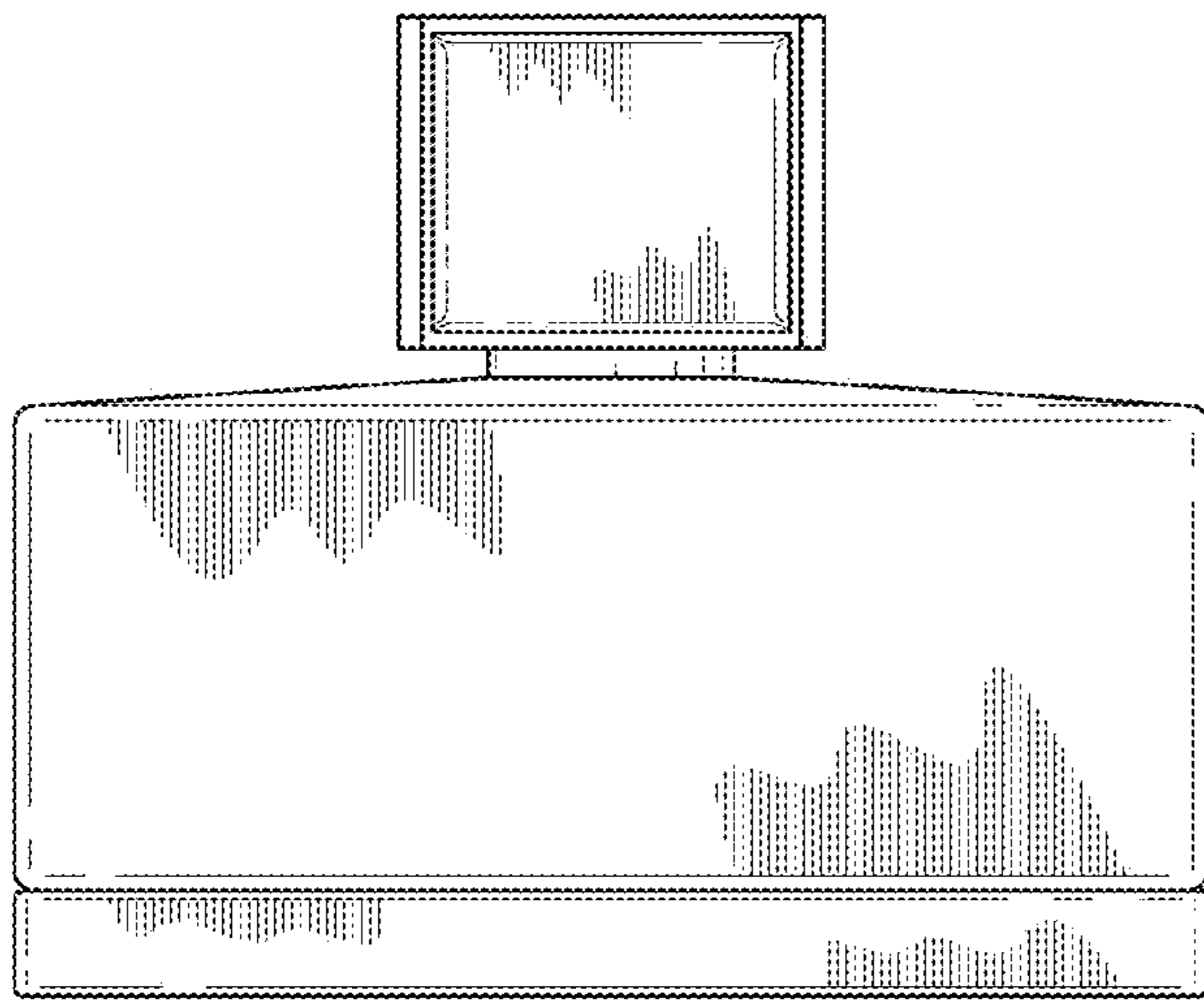

FIG. 4

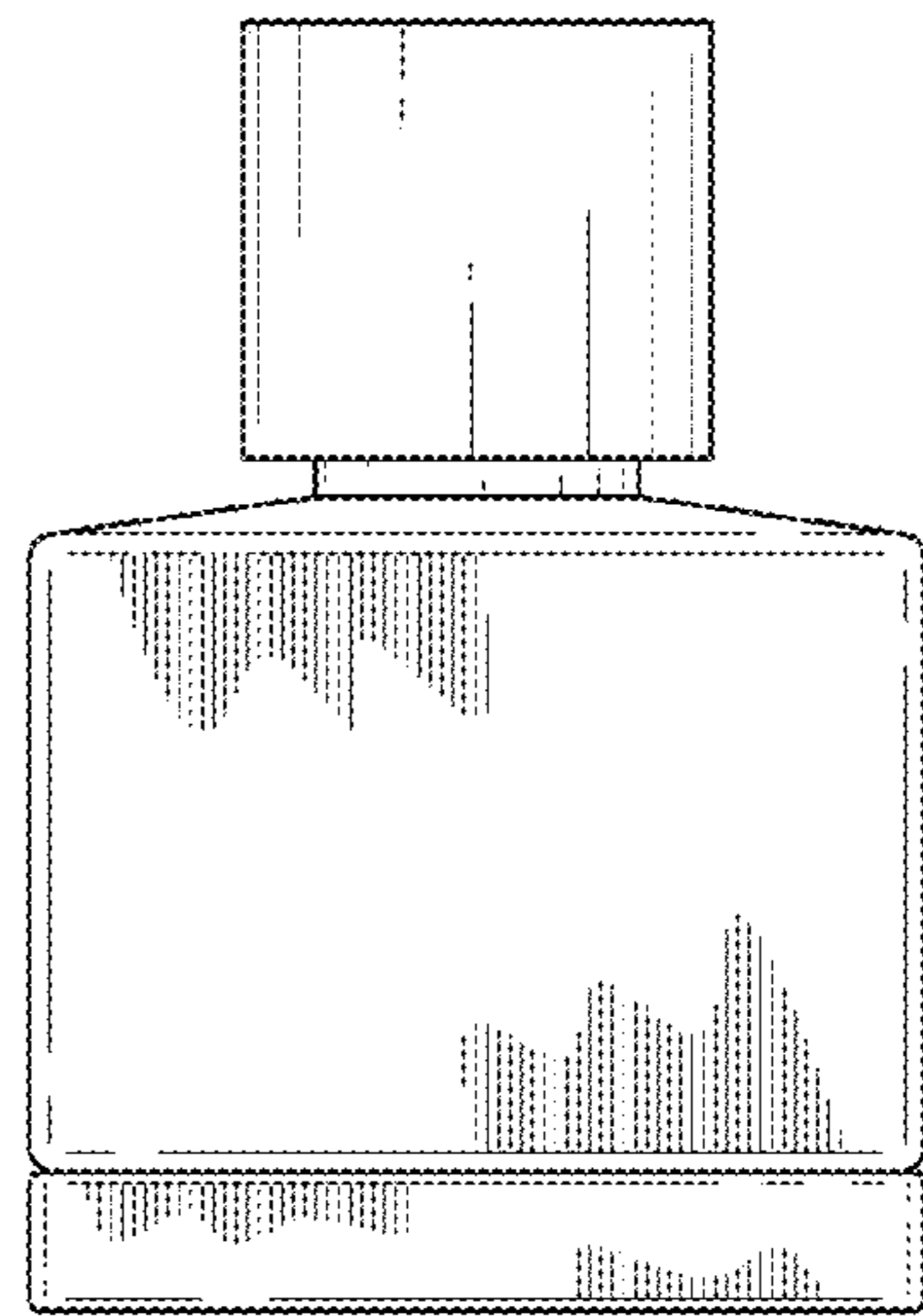

FIG. 5

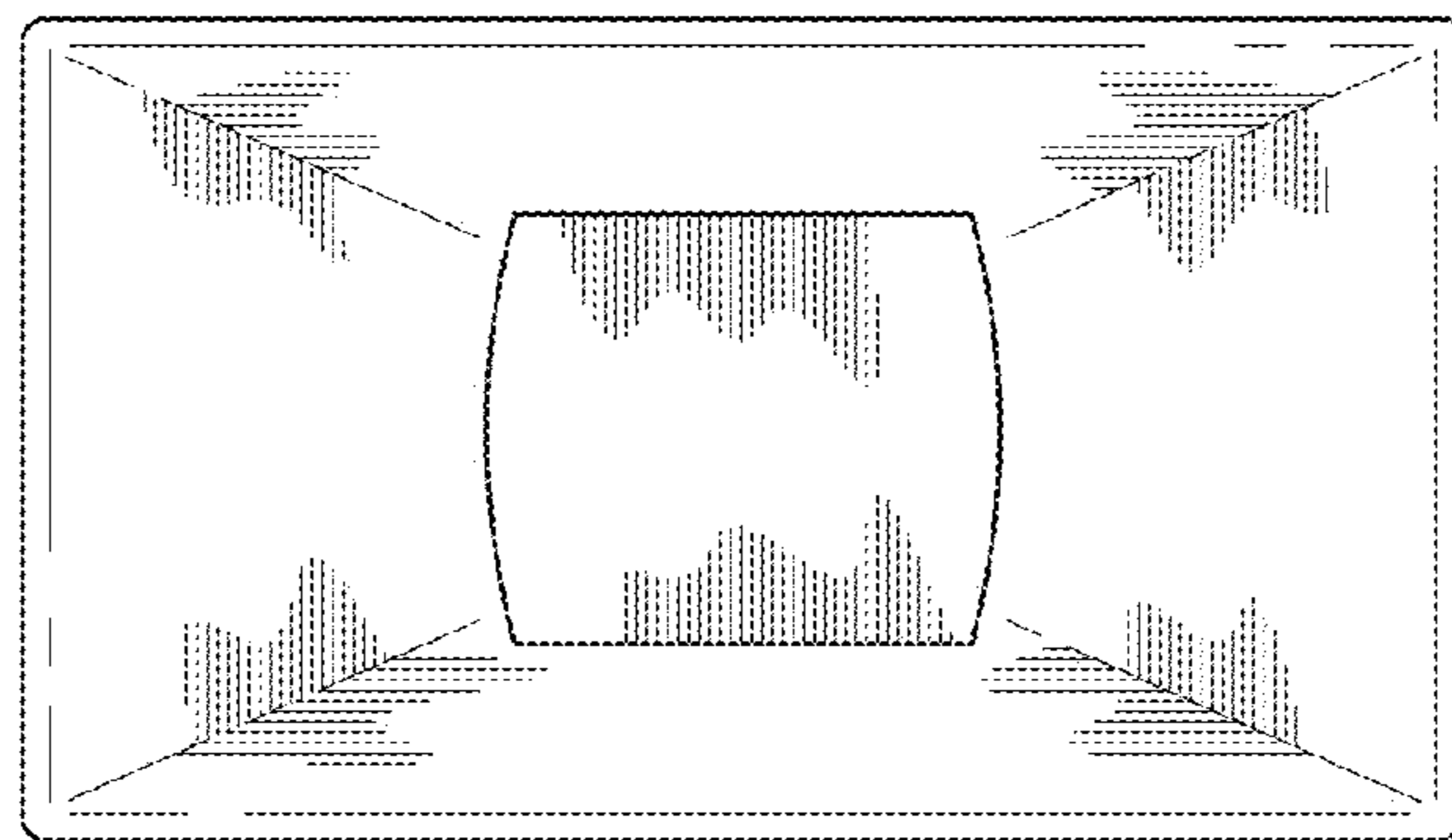

FIG. 6