



US00D757362S

(12) **United States Design Patent**  
**Dyson et al.**

(10) **Patent No.:** **US D757,362 S**  
(45) **Date of Patent:** **\*\* May 24, 2016**

(54) **HAIR DRYER**

(71) Applicant: **Dyson Technology Limited**, Wiltshire (GB)  
(72) Inventors: **James Dyson**, Bristol (GB); **Peter David Gammack**, Swindon (GB); **Stephen Benjamin Courtney**, Bath (GB); **Patrick Joseph William Moloney**, Swindon (GB); **Edward Sebert Maurice Shelton**, Swindon (GB)

(73) Assignee: **Dyson Technology Limited**, Malmesbury, Wiltshire (GB)

(\*\*) Term: **14 Years**

(21) Appl. No.: **29/504,288**

(22) Filed: **Oct. 3, 2014**

(30) **Foreign Application Priority Data**

Apr. 3, 2014 (EM) ..... 001408058-0003

(51) **LOC (10) Cl.** ..... **28-03**

(52) **U.S. Cl.**  
USPC ..... **D28/13**

(58) **Field of Classification Search**  
USPC ..... D28/12-19; 34/96-101; 392/380-385; 219/222

CPC ..... A45D 20/12; A45D 20/00  
See application file for complete search history.

(56) **References Cited**

U.S. PATENT DOCUMENTS

D257,492	S	*	11/1980	Cousins	.....	D28/13
6,889,445	B1	*	5/2005	Varona	.....	A45D 20/12 34/97
D715,995	S	*	10/2014	Dyson	.....	D28/13
D715,996	S	*	10/2014	Dyson	.....	D28/13
D716,492	S	*	10/2014	Dyson	.....	D28/13
2013/0269200	A1	*	10/2013	Moloney	.....	A45D 20/00 34/97
2013/0269201	A1	*	10/2013	Courtney	.....	A45D 20/04 34/97

\* cited by examiner

*Primary Examiner* — Zenia Bennett

(74) *Attorney, Agent, or Firm* — Morrison & Foerster LLP

(57) **CLAIM**

We claim the ornamental design for a hair dryer, as shown and described.

**DESCRIPTION**

FIG. 1 is a front perspective view of a hair dryer showing our new design;

FIG. 2 is a side perspective view thereof;

FIG. 3 is a front view thereof;

FIG. 4 is a rear view thereof;

FIG. 5 is a side view thereof;

FIG. 6 is a top view thereof; and,

FIG. 7 is a bottom view thereof.

The broken lines in the drawing are for illustrative purposes only and form no part of the claimed design.

**1 Claim, 7 Drawing Sheets**

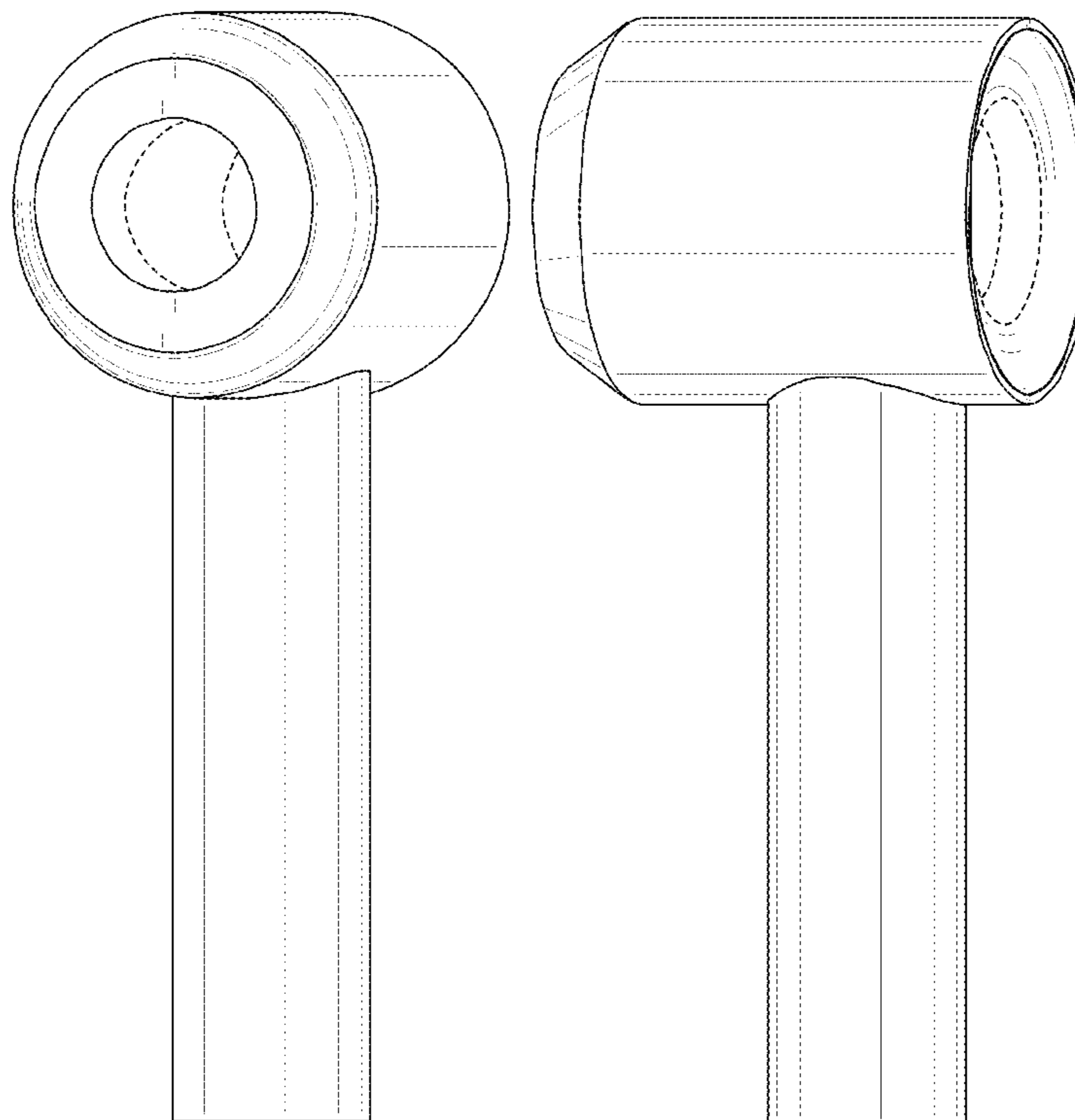

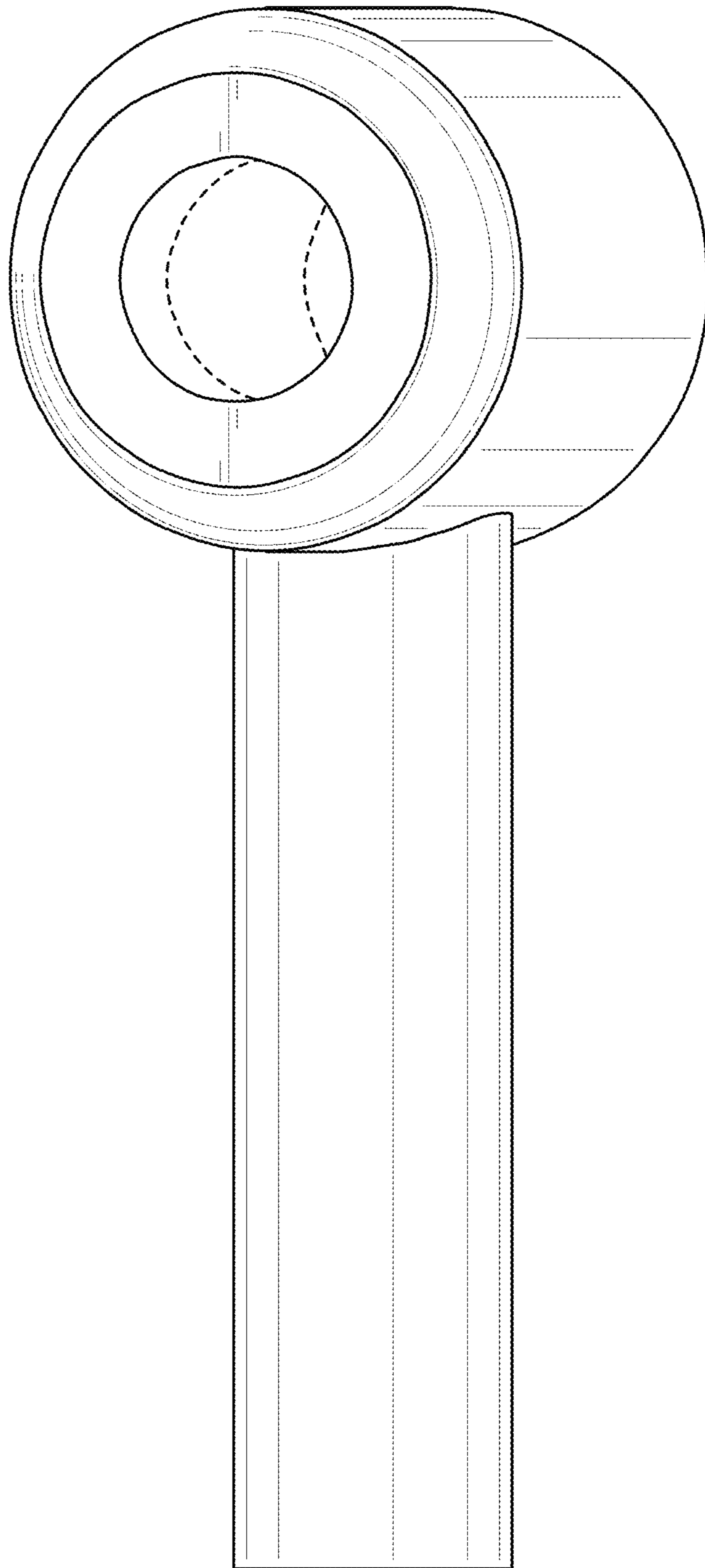

FIG. 1

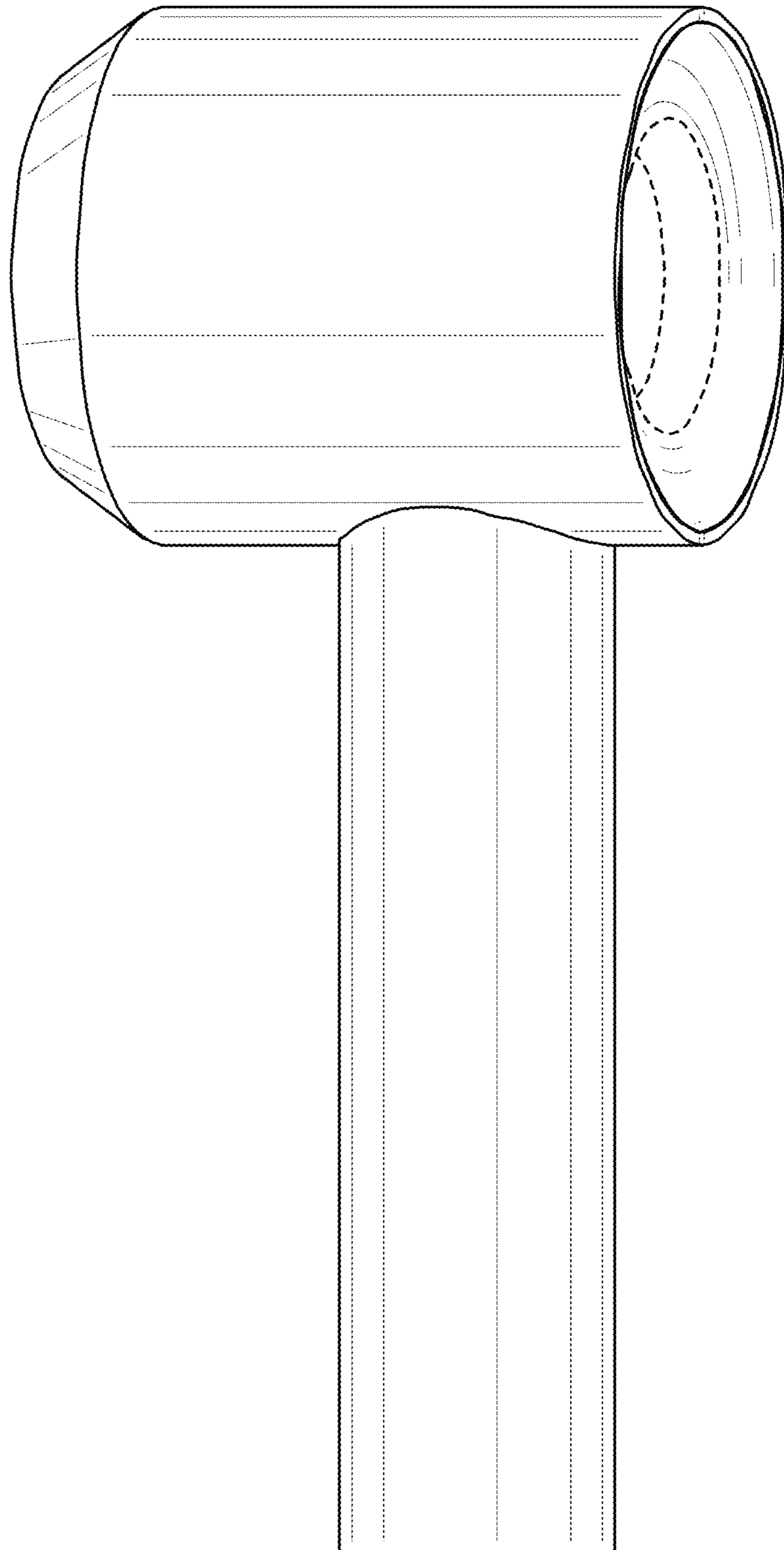

FIG. 2

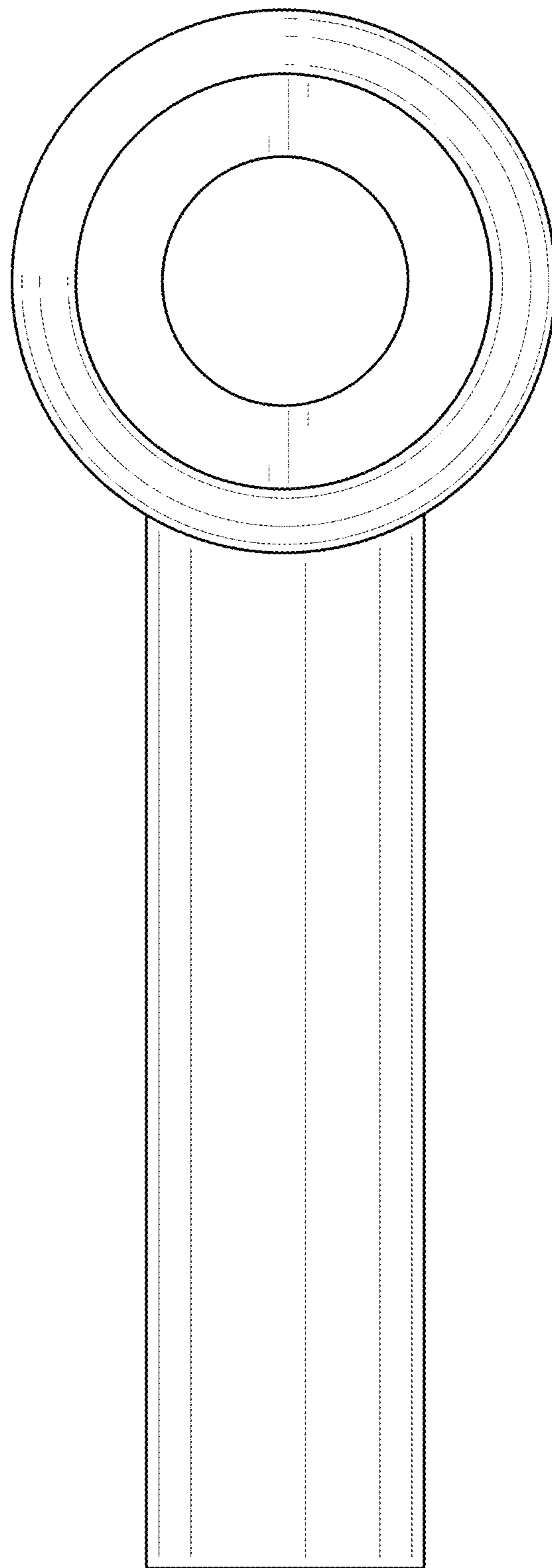

FIG. 3

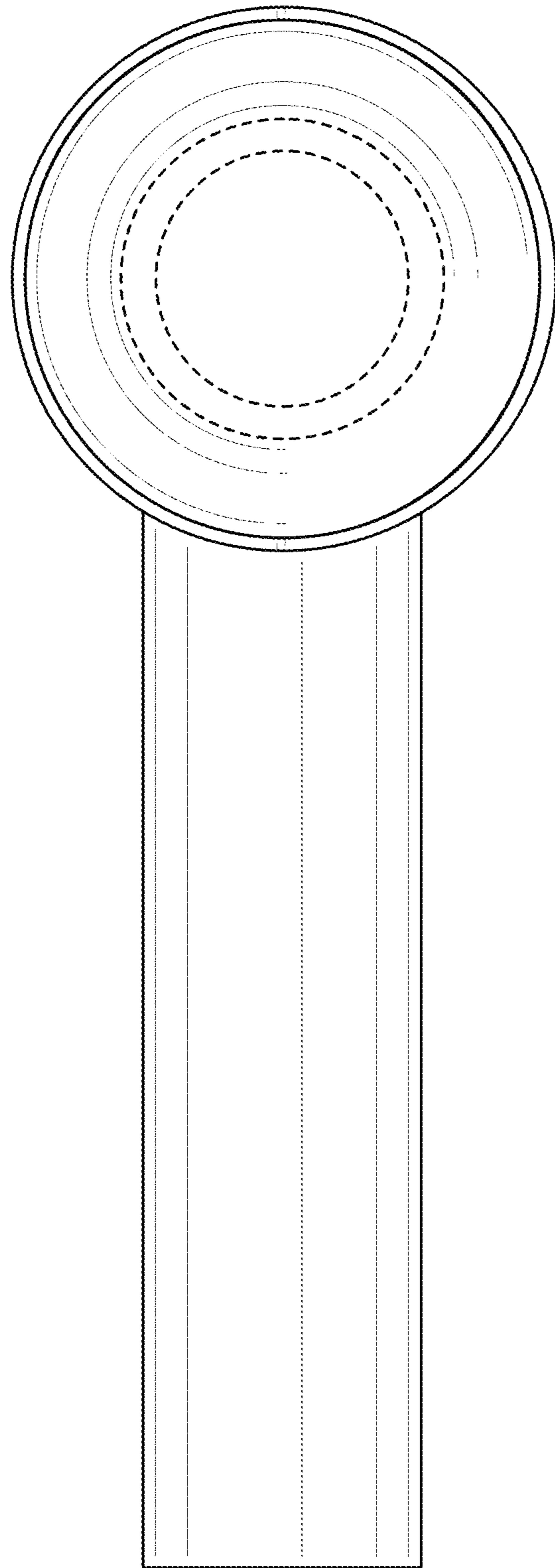

FIG. 4

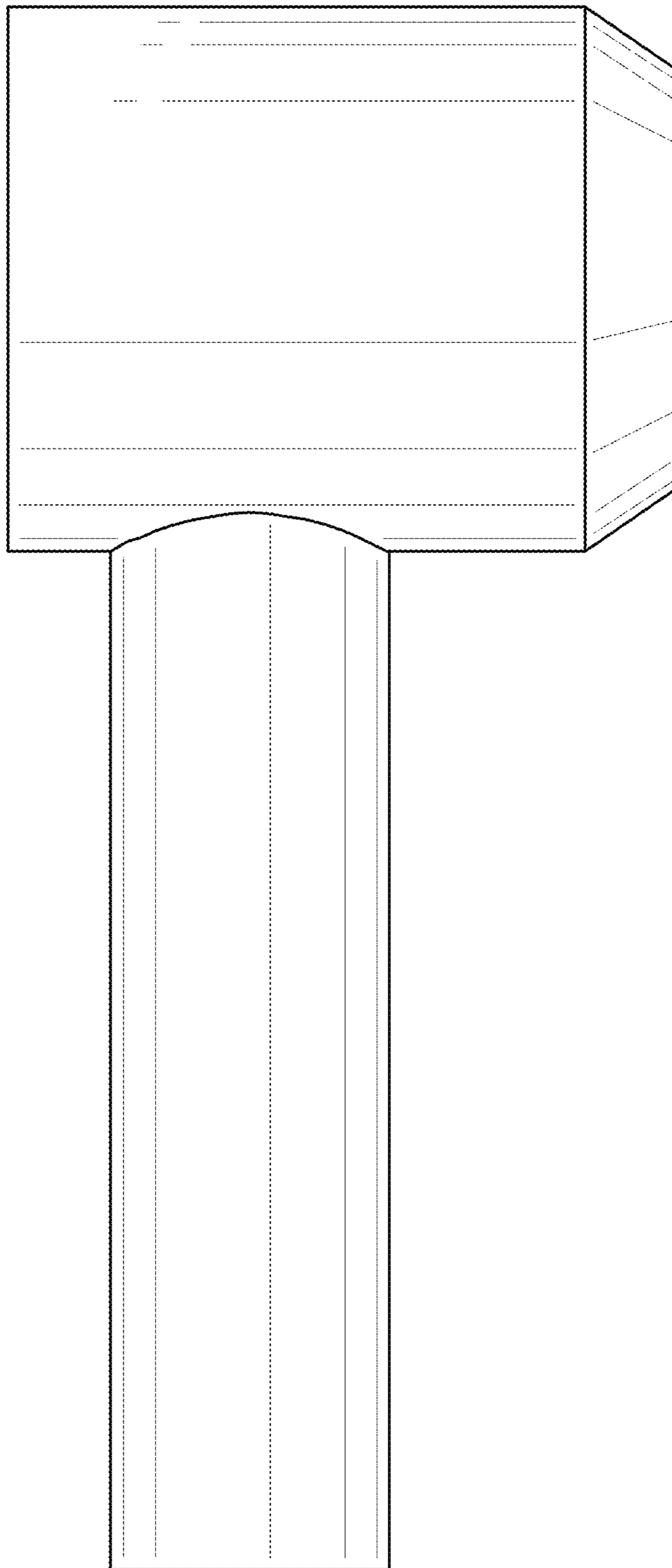

FIG. 5

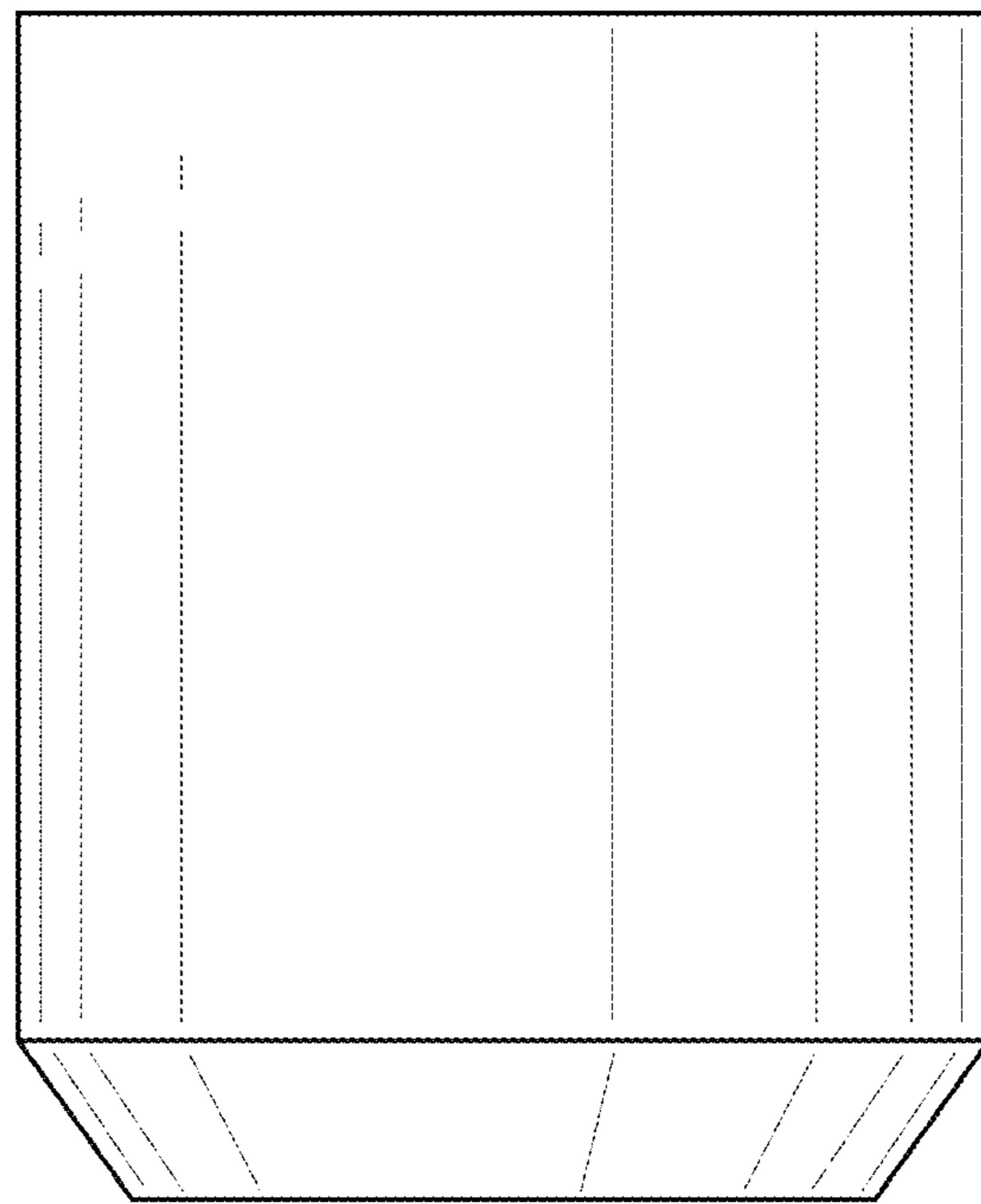

FIG. 6

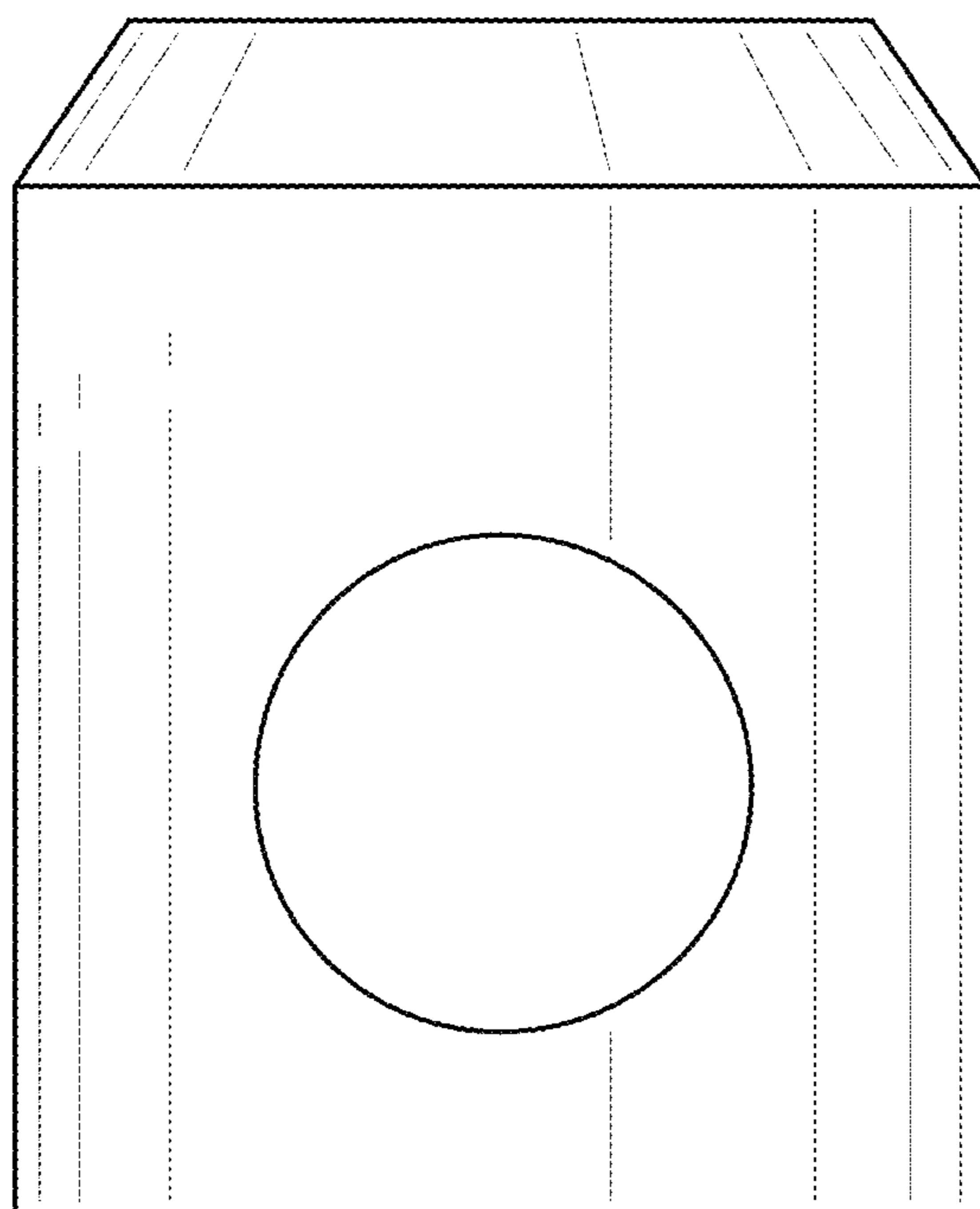

FIG. 7