



US00D757313S

(12) **United States Design Patent**
Binder et al.

(10) **Patent No.:** **US D757,313 S**

(45) **Date of Patent:** **** May 24, 2016**

(54) **TAILLIGHT FOR A VEHICLE**

(71) Applicant: **Daimler AG**, Stuttgart (DE)

(72) Inventors: **Thomas Binder**, Stuttgart (DE); **Stefan Handt**, Stuttgart (DE); **Denis Di Pardo**, Nufingen (DE); **Frederic Seemann**, Stuttgart (DE)

(73) Assignee: **Daimler AG**, Stuttgart (DE)

(**) Term: **14 Years**

(21) Appl. No.: **29/517,348**

(22) Filed: **Feb. 12, 2015**

(30) **Foreign Application Priority Data**

Aug. 13, 2014 (WO) DM/084 197

(51) **LOC (10) Cl.** **26-06**

(52) **U.S. Cl.**
USPC **D26/28**

(58) **Field of Classification Search**

USPC D26/28-36; 362/459-468, 475-478,
362/485-487

CPC F21S 48/00; F21S 48/10; F21S 48/115;
F21S 48/225; F21S 48/1233; F21S 48/1266;
F21S 48/1388; F21S 48/2268; F21V 21/04

See application file for complete search history.

(56) **References Cited**

U.S. PATENT DOCUMENTS

D549,363 S * 8/2007 Pfeiffer D26/28
D552,769 S * 10/2007 Leclercq D26/28
D553,269 S * 10/2007 Pfeiffer D26/28
D570,015 S * 5/2008 Hsu D26/28
D574,524 S * 8/2008 Tomatsu D26/28

D592,325 S 5/2009 Bauer et al.
D592,326 S 5/2009 Bauer et al.
D592,770 S 5/2009 Bauer et al.
D596,078 S * 7/2009 Pfeiffer D12/92
D605,793 S * 12/2009 Weil D26/28
D688,823 S 8/2013 Binder et al.
D691,299 S * 10/2013 Binder D26/28

* cited by examiner

Primary Examiner — Marcus Jackson

(74) *Attorney, Agent, or Firm* — Crowell & Moring LLP

(57) **CLAIM**

The ornamental design for a taillight for a vehicle, as shown and described.

DESCRIPTION

This application contains subject matter related to the following co-pending U.S. design patent application: application Ser. No. 29/517,349, filed herewith and entitled "Taillight for a Vehicle".

FIG. 1 is a left perspective view of a first embodiment of a taillight for a vehicle according to the design;

FIG. 2 is a left side view thereof;

FIG. 3 is a front view thereof; and

FIG. 4 is a top view thereof.

FIG. 5 is a right perspective view of a second embodiment of a taillight for a vehicle thereof, with the taillight for a vehicle for the opposite side of the vehicle being depicted in the first embodiment;

FIG. 6 is a right side view thereof;

FIG. 7 is a front view thereof; and,

FIG. 8 is a top view thereof.

The broken lines are for illustrative purposes only and form no part of the claimed design.

1 Claim, 4 Drawing Sheets

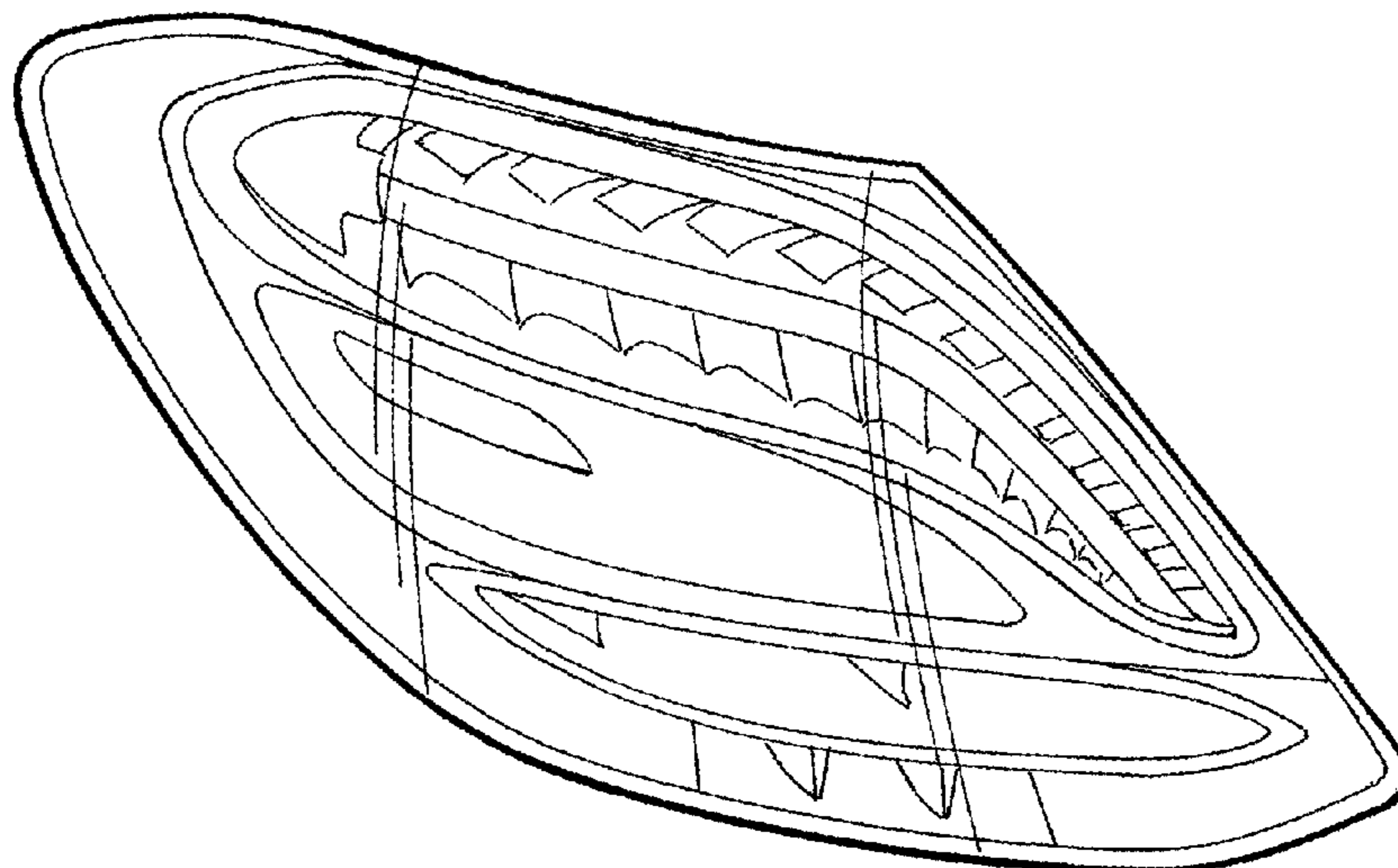

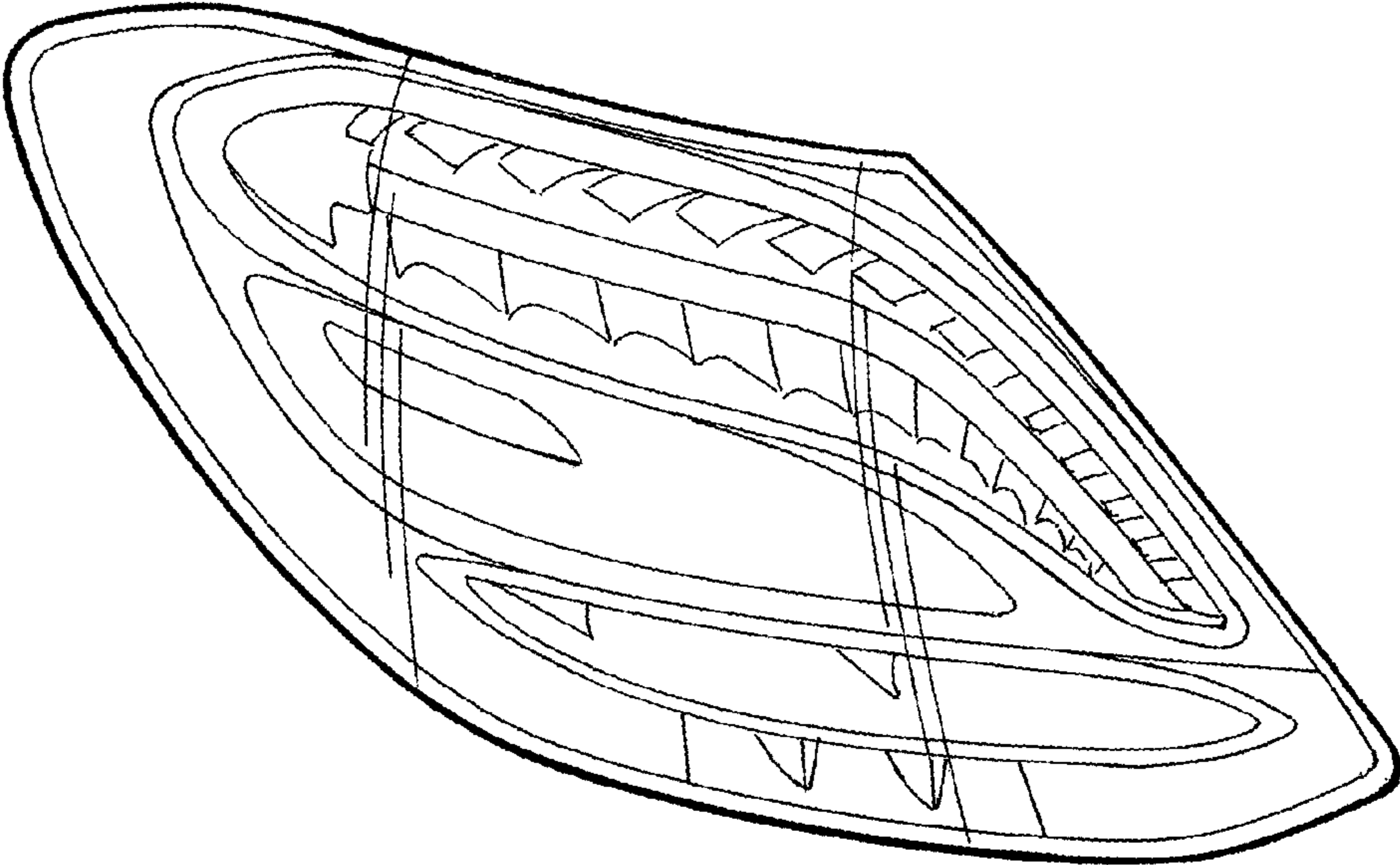

FIG. 1

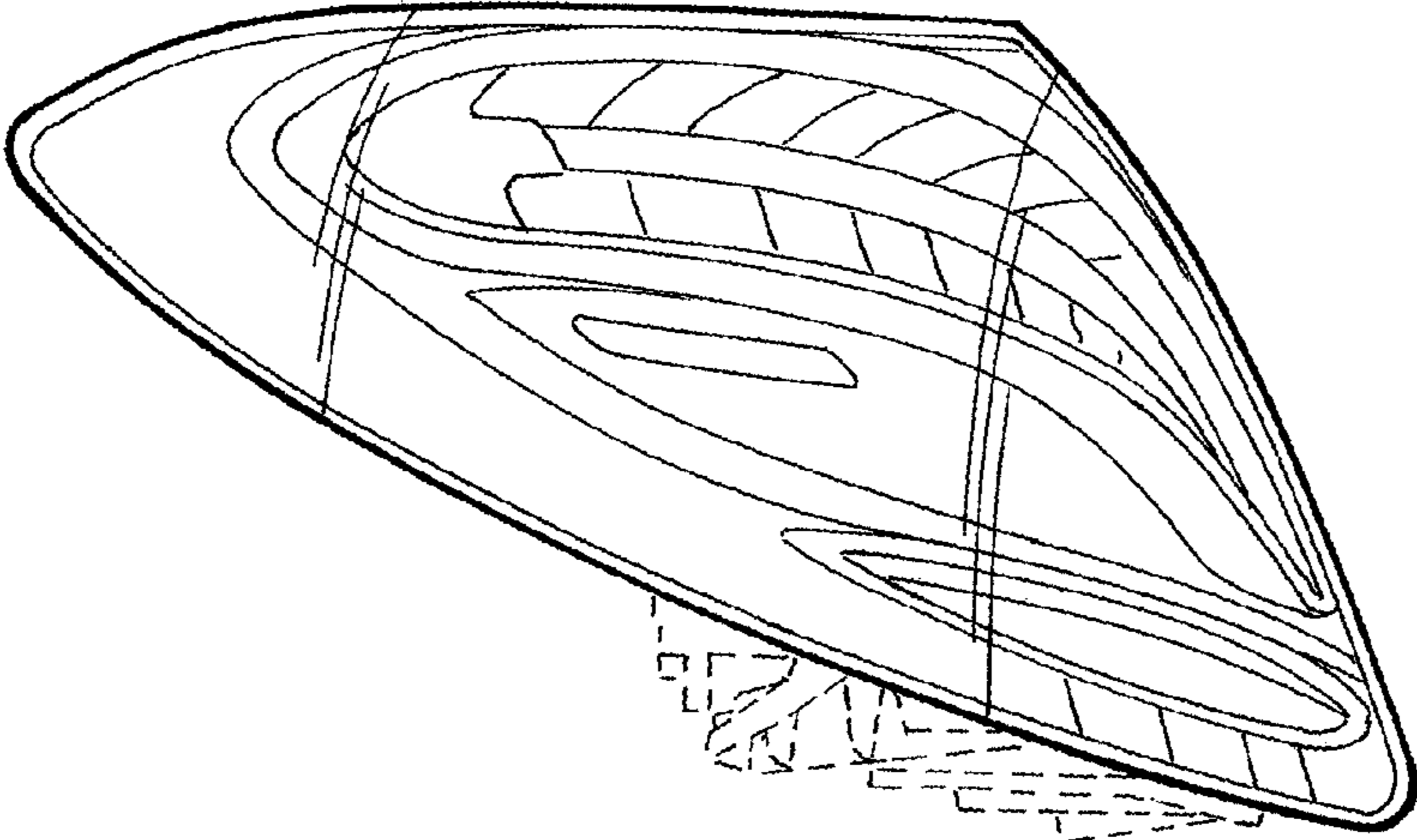

FIG. 2

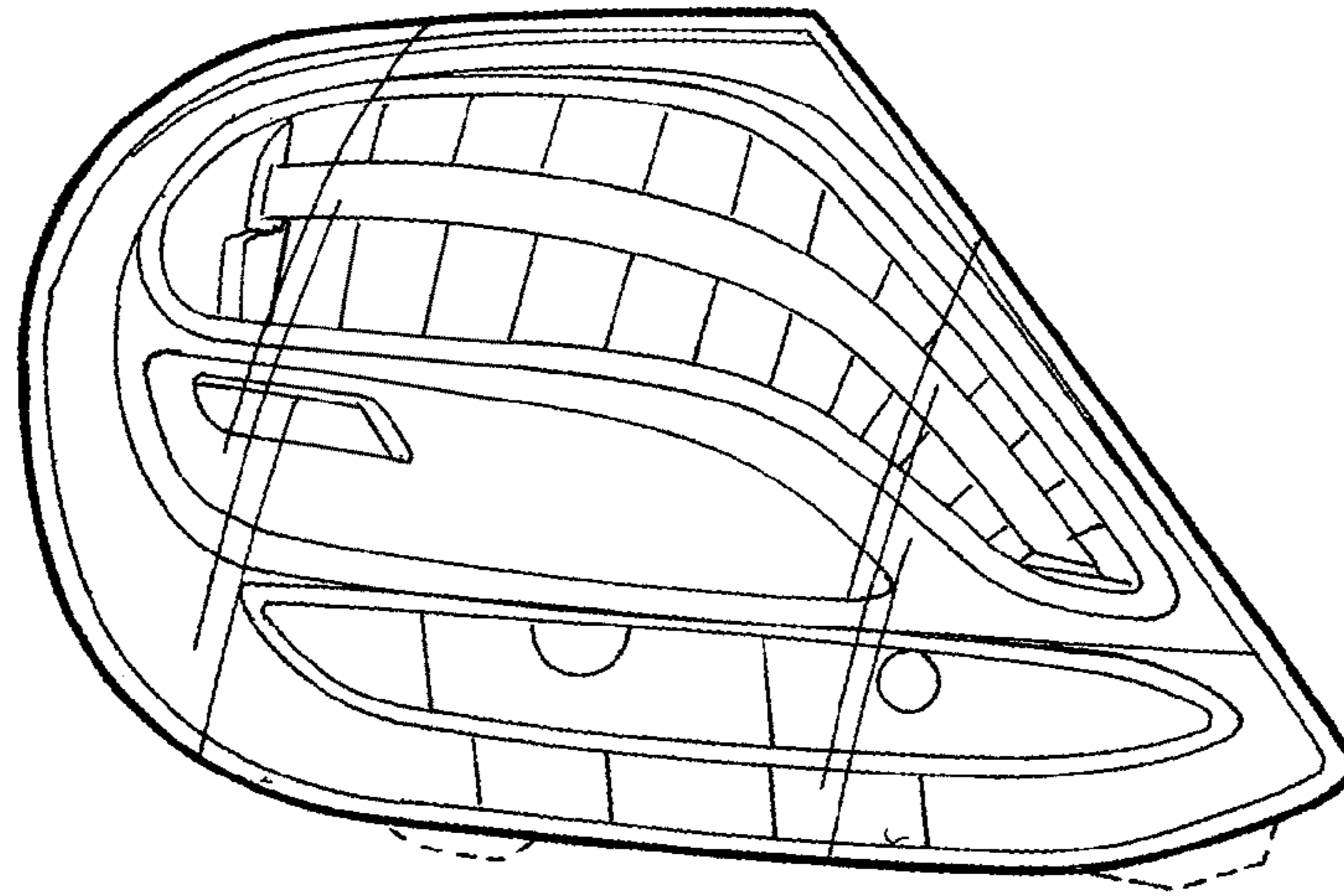

FIG. 3

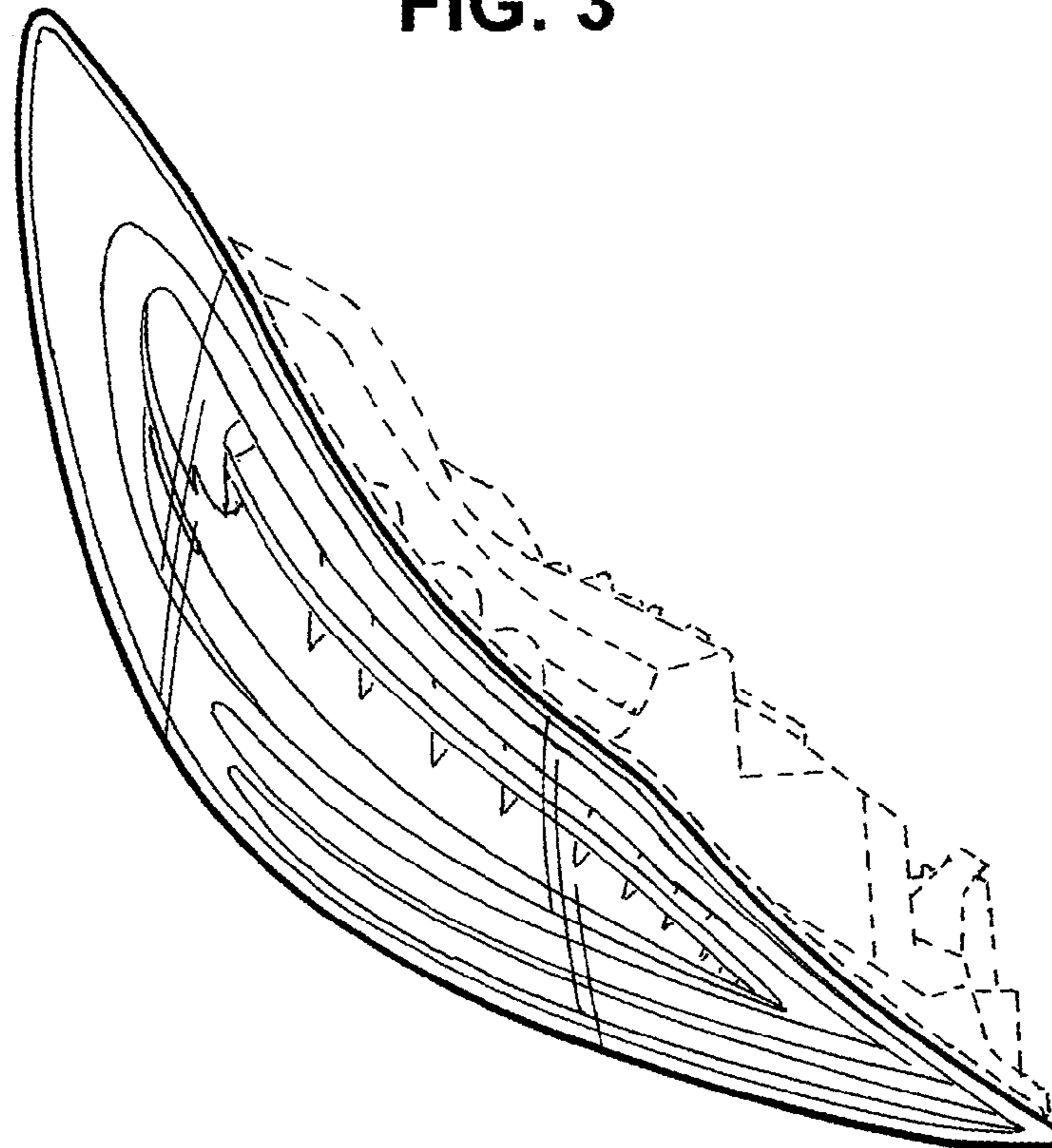

FIG. 4

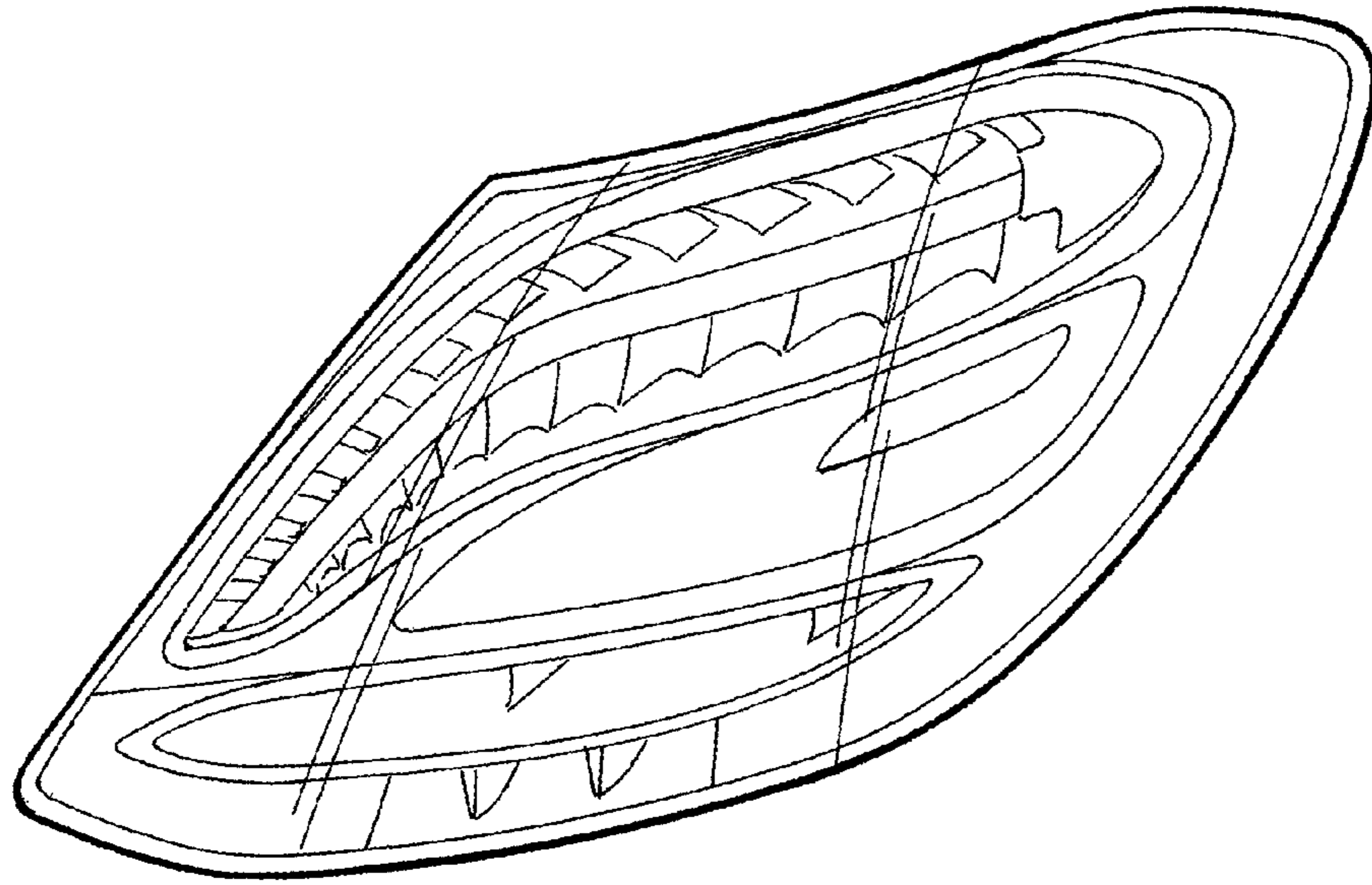

FIG. 5

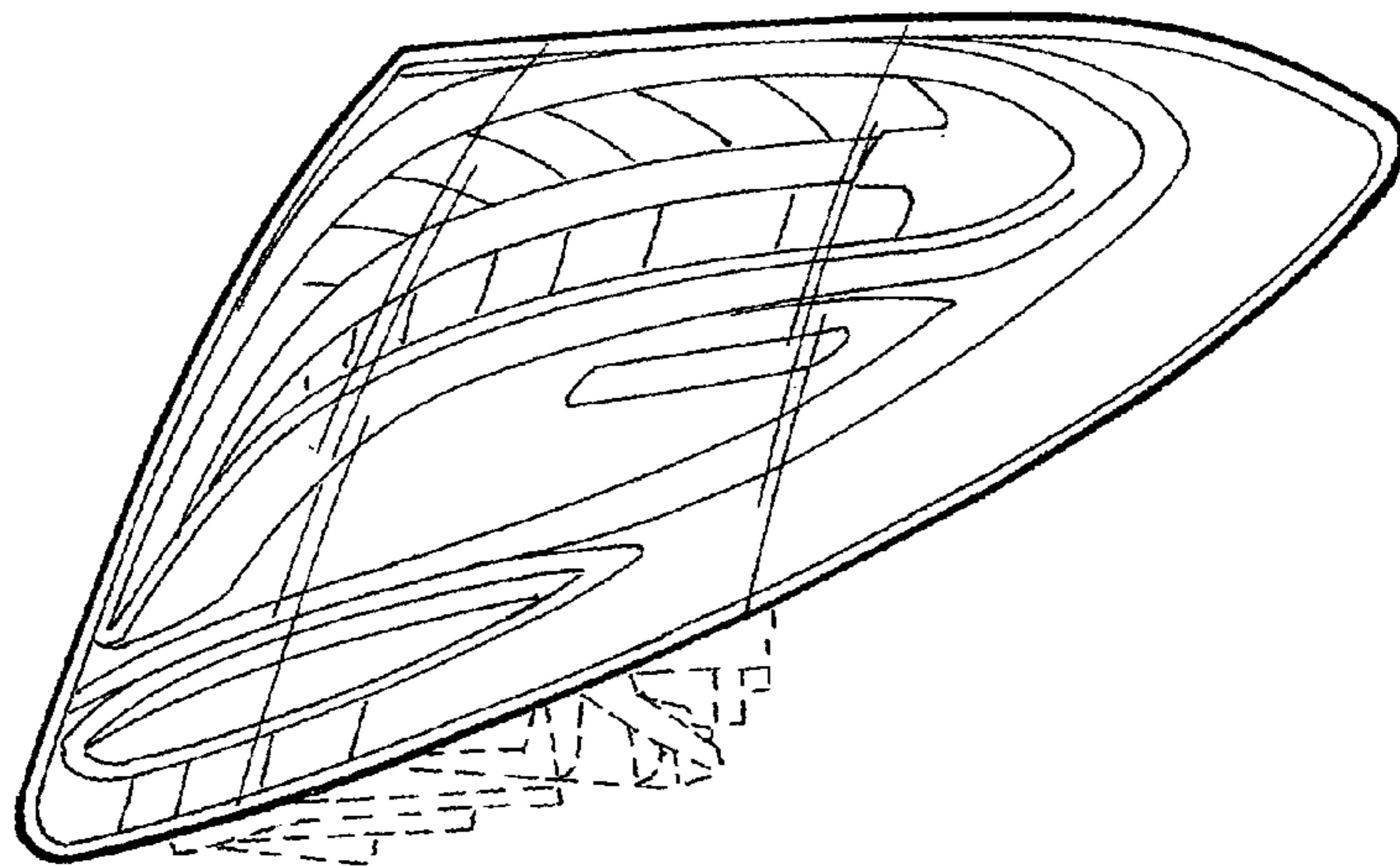

FIG. 6

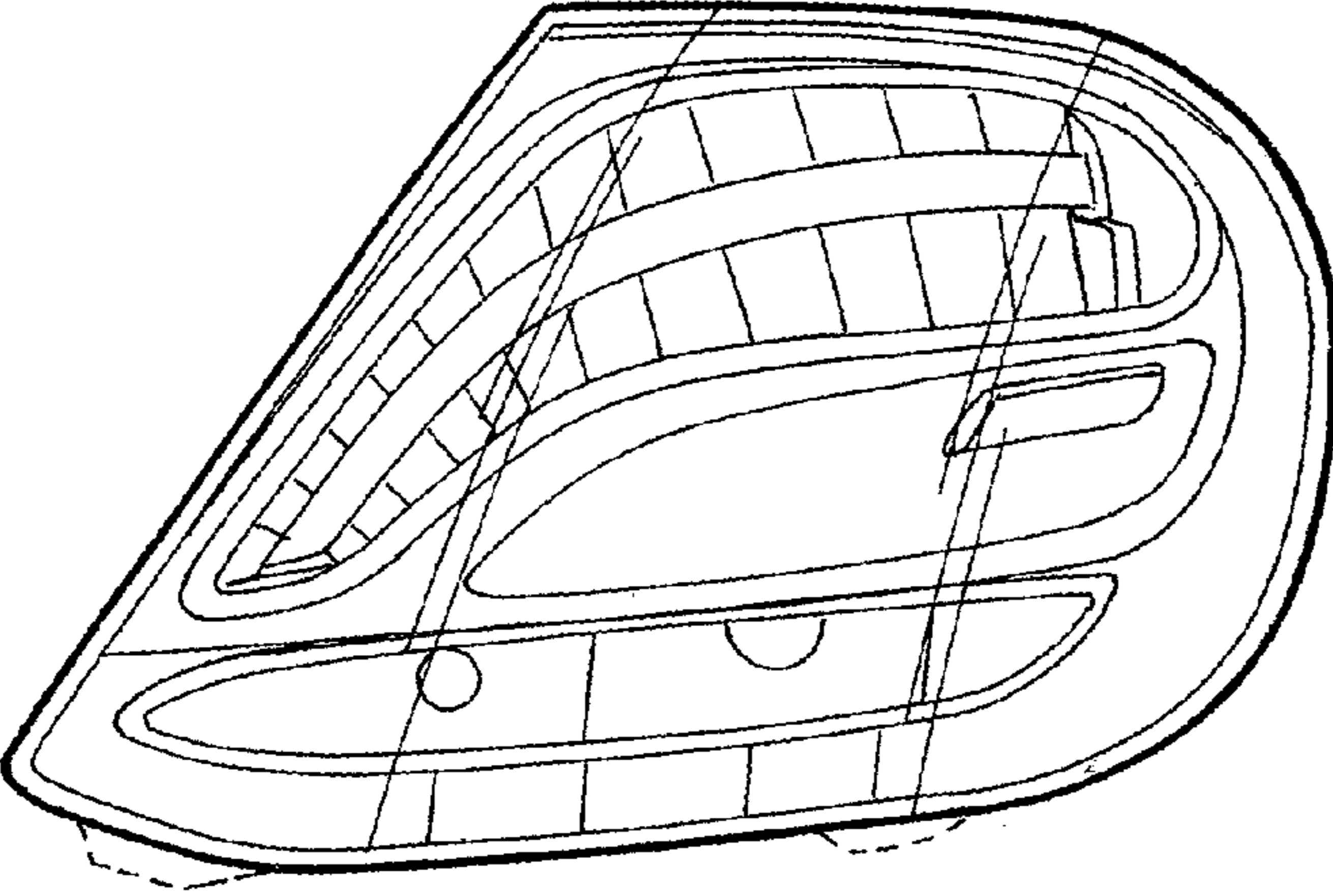

FIG. 7

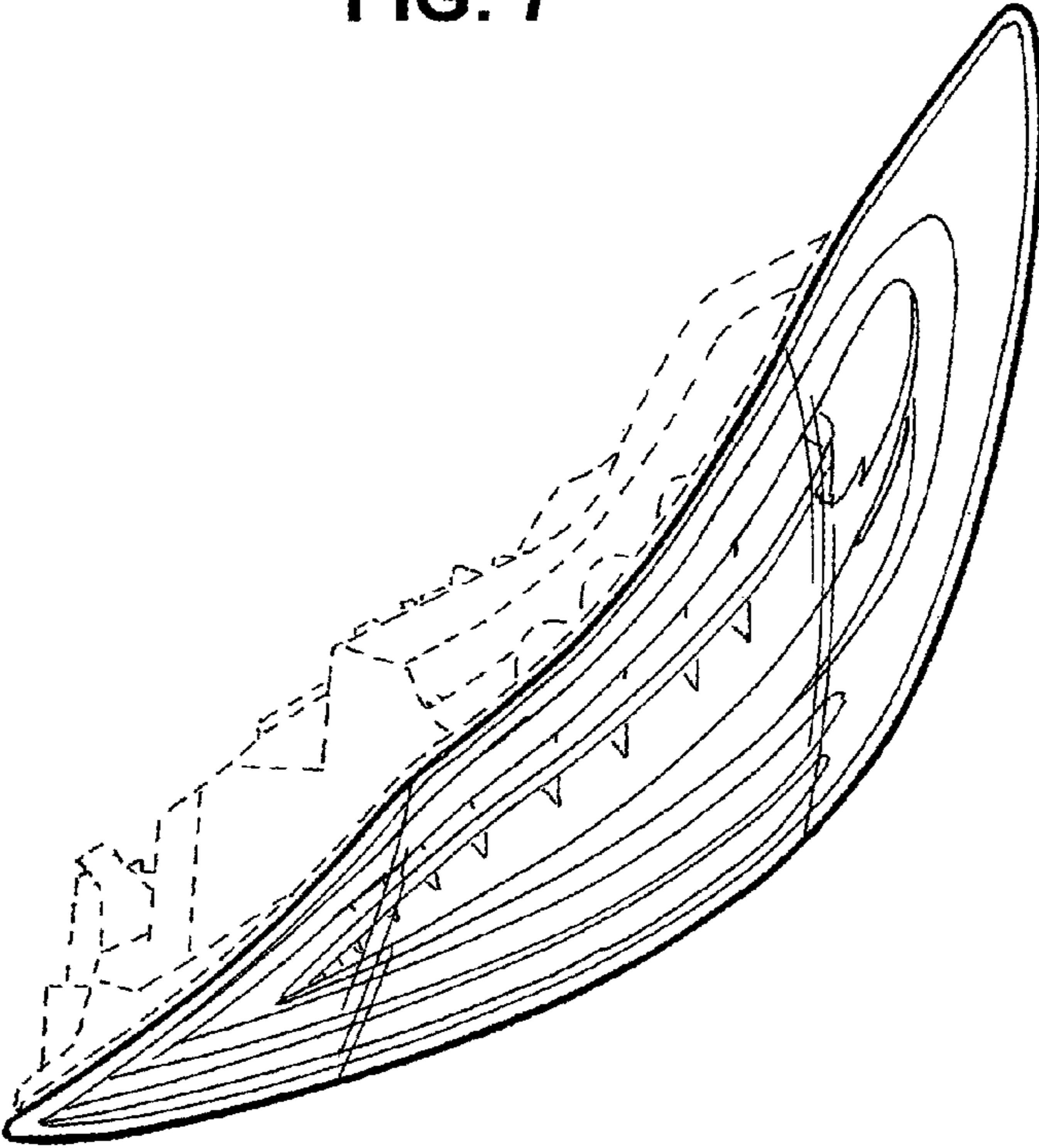

FIG. 8