

US00D756941S

(12) **United States Design Patent**  
**Zheng et al.**

(10) **Patent No.:** **US D756,941 S**

(45) **Date of Patent:** **\*\* May 24, 2016**

(54) **CAM SWITCH**

(71) Applicant: **ABB Oy**, Helsinki (FI)

(72) Inventors: **Qifeng Zheng**, Quanzhou (CN); **Qishun Guo**, Fujian (CN); **Xinde Lin**, Wenling (CN); **Jiejun Lu**, Fujian (CN); **Shujing Ye**, Fujian (CN)

(73) Assignee: **ABB OY**, Helsinki (FI)

(\*\*) Term: **15 Years**

(21) Appl. No.: **29/531,926**

(22) Filed: **Jun. 30, 2015**

**Related U.S. Application Data**

(62) Division of application No. 29/443,176, filed on Jan. 14, 2013, now Pat. No. Des. 738,323.

(30) **Foreign Application Priority Data**

Jul. 16, 2012 (CN) ..... 2012 3 0328647

(51) **LOC (10) Cl.** ..... **13-03**

(52) **U.S. Cl.**  
USPC ..... **D13/169**; D13/158

(58) **Field of Classification Search**  
USPC ..... D13/158, 160, 162, 169, 171, 178  
CPC ..... H01H 1/02; H01H 1/08; H01H 1/20;  
H01H 3/20; H01H 3/40; H01H 3/42; H01H  
9/22; H01H 9/282; H01H 19/00; H01H  
19/035; H01H 19/114; H01H 19/6355;  
H01H 19/64

See application file for complete search history.

(56) **References Cited**

**U.S. PATENT DOCUMENTS**

4,335,288 A 6/1982 Ludwig et al.  
4,713,498 A 12/1987 Ludwig et al.

(Continued)

*Primary Examiner* — Selina Sikder

(74) *Attorney, Agent, or Firm* — Buchanan, Ingersoll & Rooney PC

(57) **CLAIM**

The ornamental design for a cam switch, as shown and described.

**DESCRIPTION**

FIG. 1 is a perspective view of a cam switch showing a first embodiment of our new design.

FIG. 2 is a front elevational view thereof.

FIG. 3 is a rear elevational view thereof drawn at a larger scale for ease of illustration.

FIG. 4 is a left side elevational view thereof.

FIG. 5 is a right side elevational view thereof.

FIG. 6 is a top plan view thereof.

FIG. 7 is a bottom plan view thereof.

FIG. 8 is a perspective view of a cam switch showing a second embodiment of our new design.

FIG. 9 is a front elevational view thereof.

FIG. 10 is a rear elevational view thereof drawn at a larger scale for ease of illustration.

FIG. 11 is a left side elevational view thereof.

FIG. 12 is a right side elevational view thereof.

FIG. 13 is a top plan view thereof.

FIG. 14 is a bottom plan view thereof.

FIG. 15 is a perspective view of a cam switch showing a third embodiment of our new design.

FIG. 16 is a front elevational view thereof.

FIG. 17 is a rear elevational view thereof drawn at a larger scale for ease of illustration.

FIG. 18 is a left side elevational view thereof.

FIG. 19 is a right side elevational view thereof.

FIG. 20 is a top plan view thereof.

FIG. 21 is a bottom plan view thereof.

FIG. 22 is a perspective view of a cam switch showing a fourth embodiment of our new design.

FIG. 23 is a front elevational view thereof.

FIG. 24 is a rear elevational view thereof drawn at a larger scale for ease of illustration.

FIG. 25 is a left side elevational view thereof.

FIG. 26 is a right side elevational view thereof.

FIG. 27 is a top plan view thereof.

FIG. 28 is a bottom plan view thereof; and,

FIG. 29 is an enlarged bottom plan view of the lower end unit shown in FIGS. 7, 14, 21, and 28 views drawn at a larger scale for ease of illustration.

The broken line showing of the cam switch is for the purpose of illustrating environmental structure and forms no part of the claimed design.

**1 Claim, 29 Drawing Sheets**

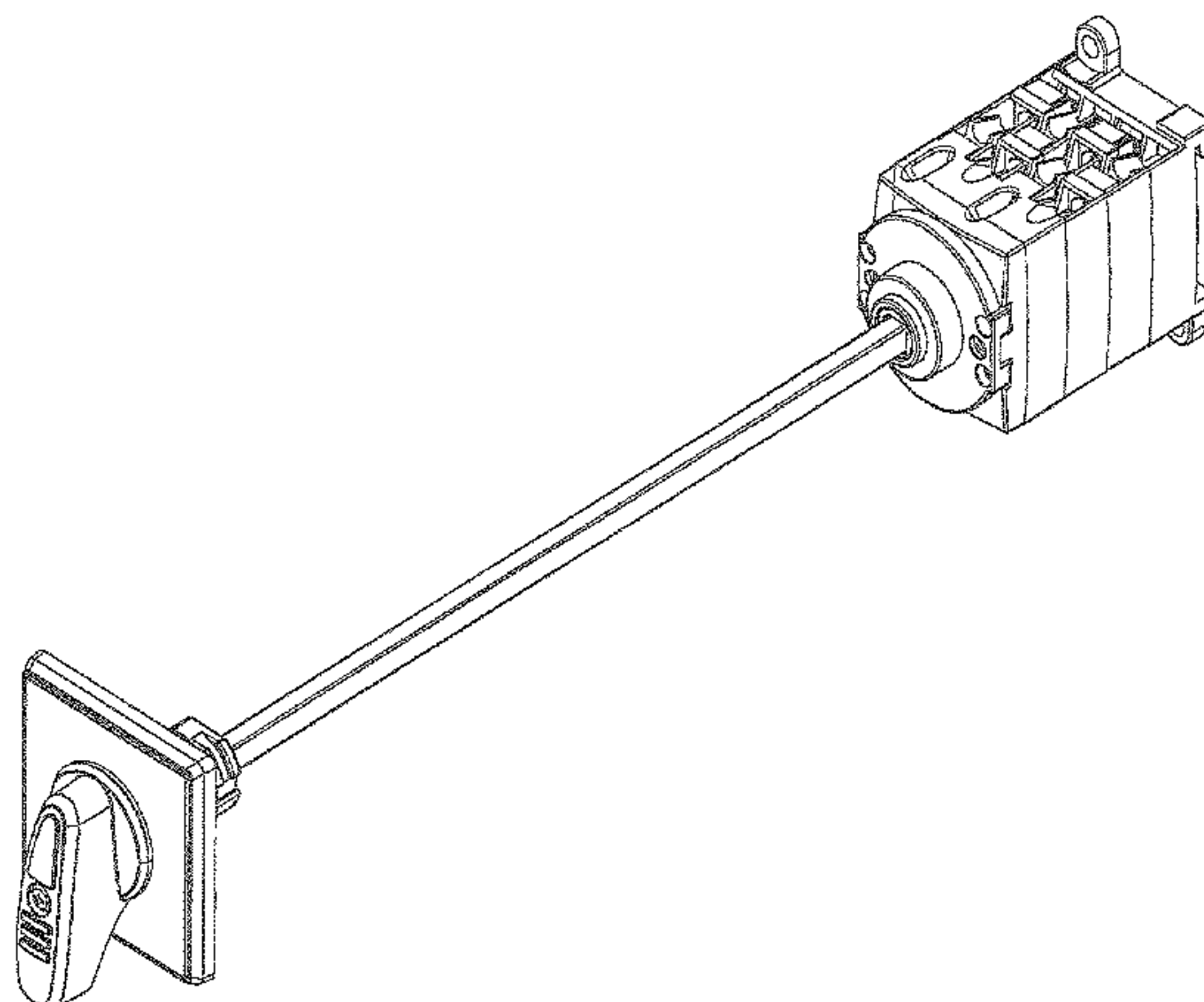

(56)

References Cited

U.S. PATENT DOCUMENTS

4,851,620 A 7/1989 Schaeffer  
4,861,949 A 8/1989 Bortolloni et al.  
D393,626 S 4/1998 Siat  
6,072,128 A 6/2000 Ansorge et al.  
6,423,912 B1 7/2002 Arenz et al.  
6,576,851 B1 6/2003 Barlian et al.  
6,969,813 B1 11/2005 Winslett et al.  
7,368,675 B2 5/2008 Ishido et al.  
7,514,645 B2 4/2009 Shahmuradyan  
7,870,810 B2 1/2011 Da Dalt et al.

D658,597 S 5/2012 Kuwae et al.  
D738,322 S \* 9/2015 Zheng ..... D13/158  
D738,323 S \* 9/2015 Zheng ..... D13/158  
D738,324 S \* 9/2015 Zheng ..... D13/158  
2012/0080298 A1 4/2012 Lee  
2014/0097155 A1\* 4/2014 Uitto ..... H01H 1/2041  
218/154  
2014/0144761 A1\* 5/2014 Webber ..... H01H 19/02  
200/11 A  
2014/0326585 A1 11/2014 Reinhart et al.  
2015/0008108 A1\* 1/2015 Wu ..... H01R 4/38  
200/293

\* cited by examiner

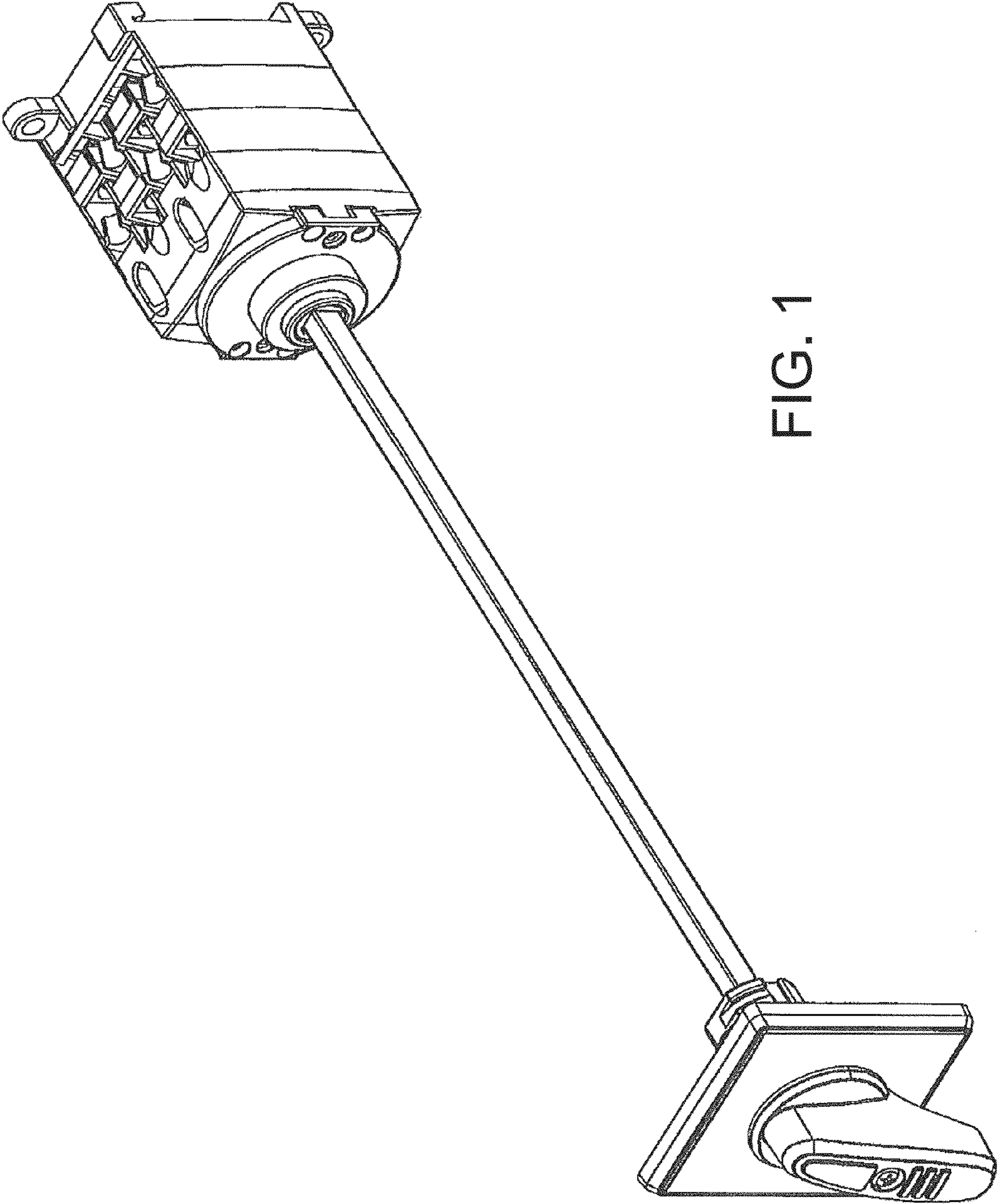

FIG. 1

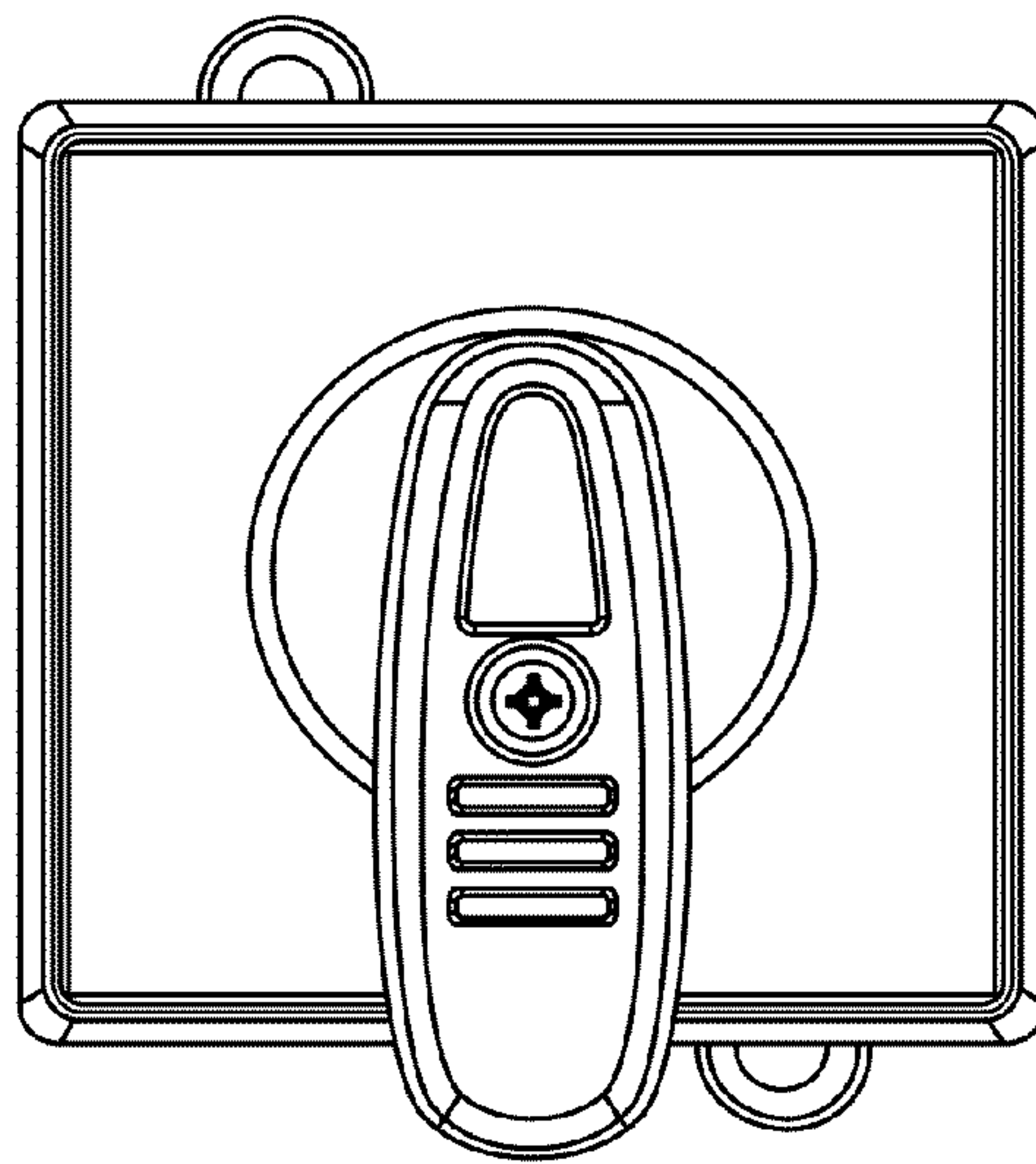

FIG. 2



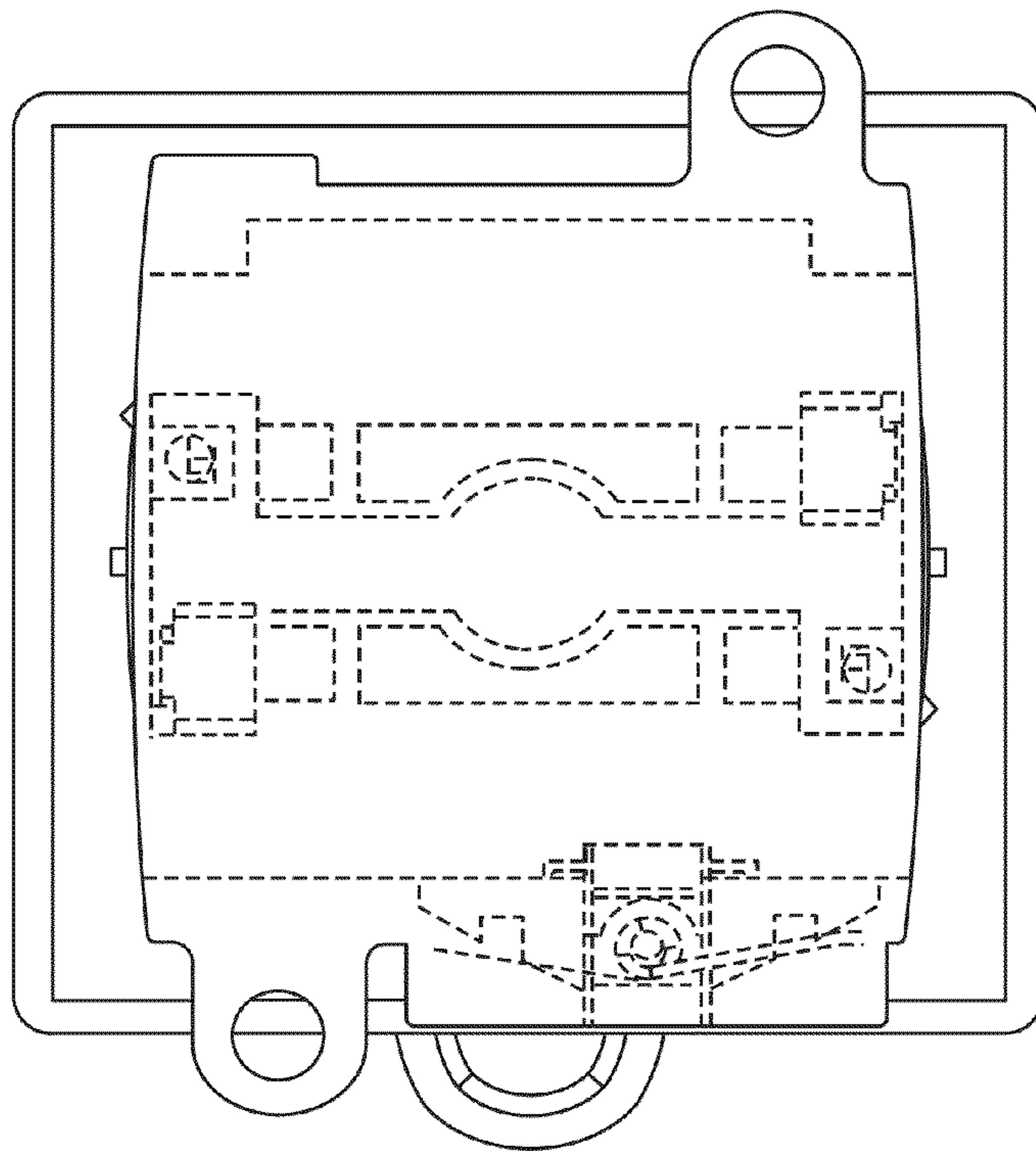

FIG. 3

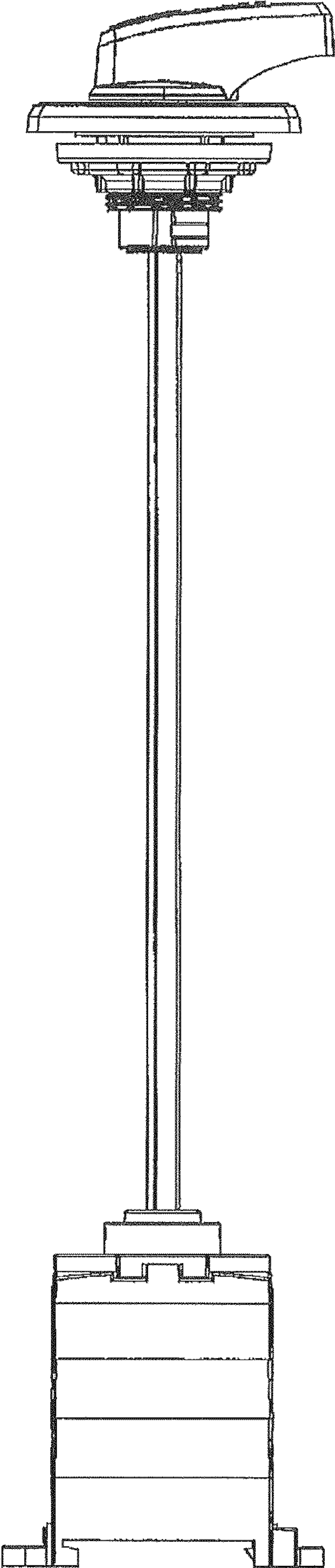

FIG. 4

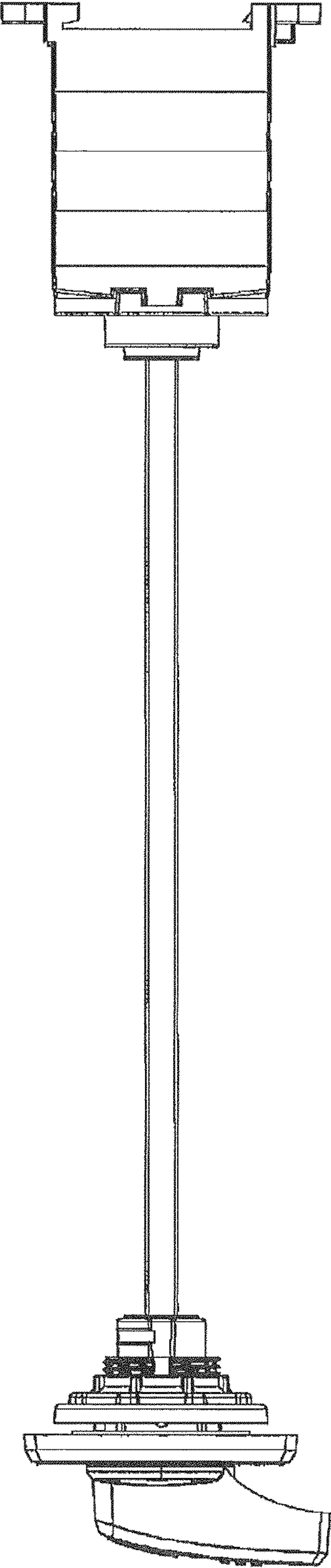

FIG. 5

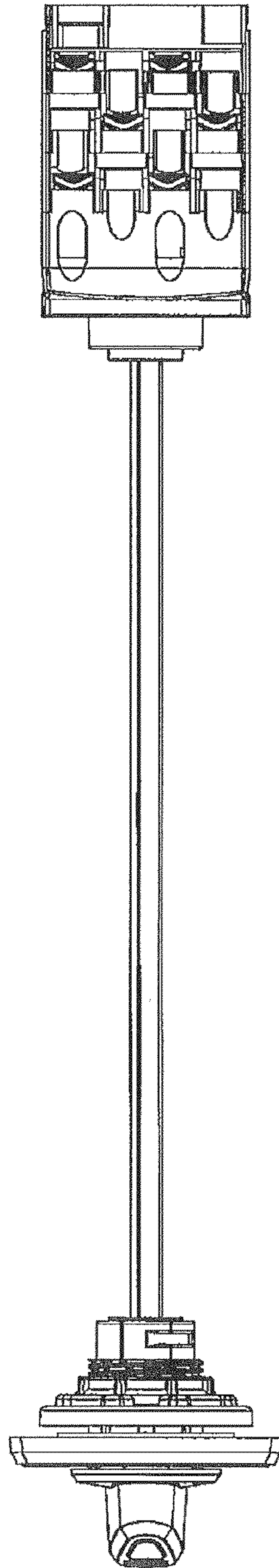

FIG. 6



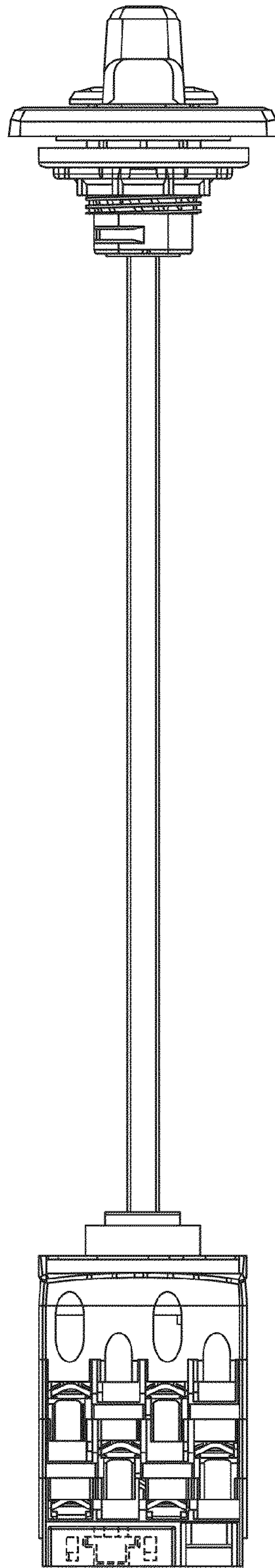

FIG. 7

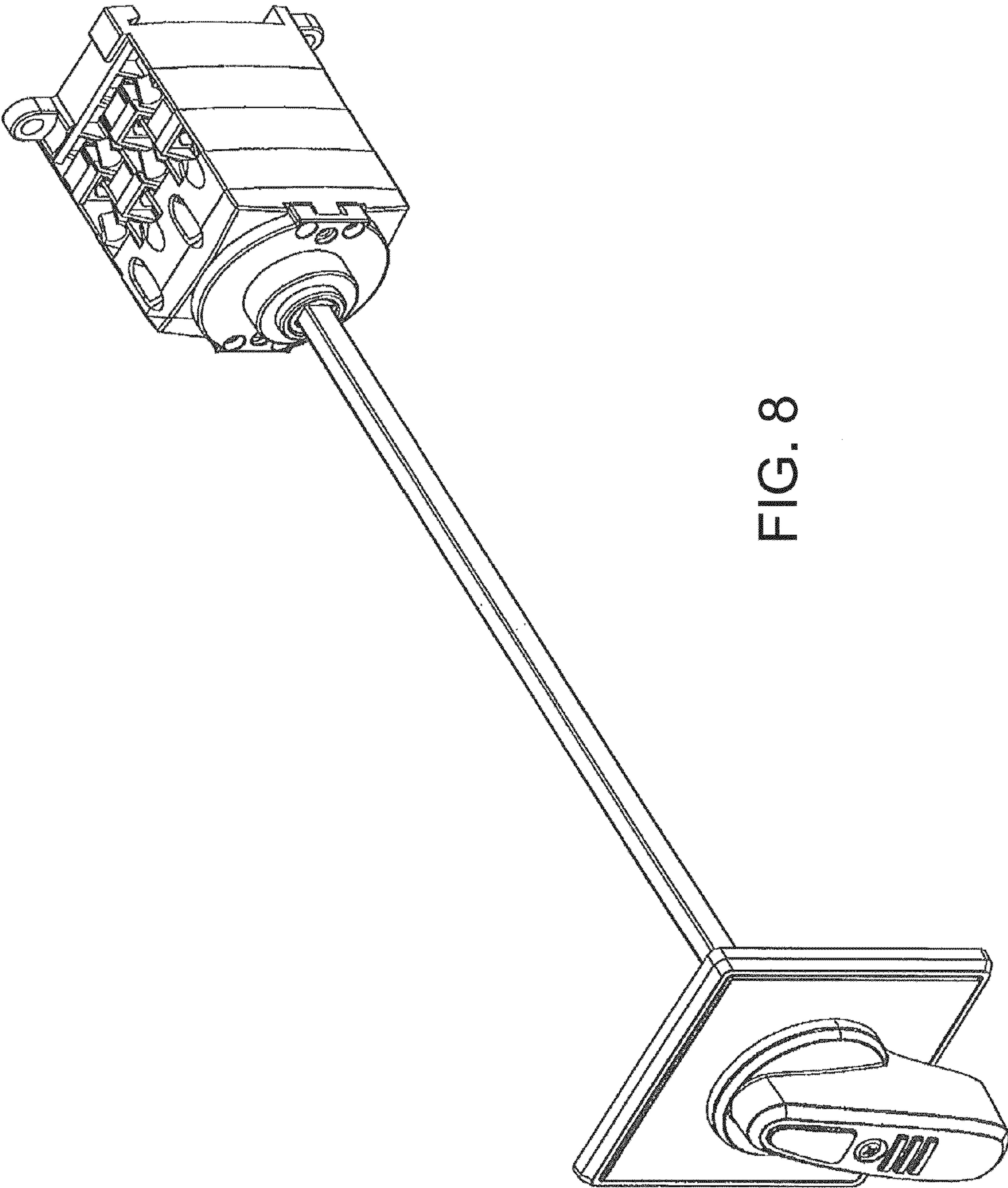

FIG. 8

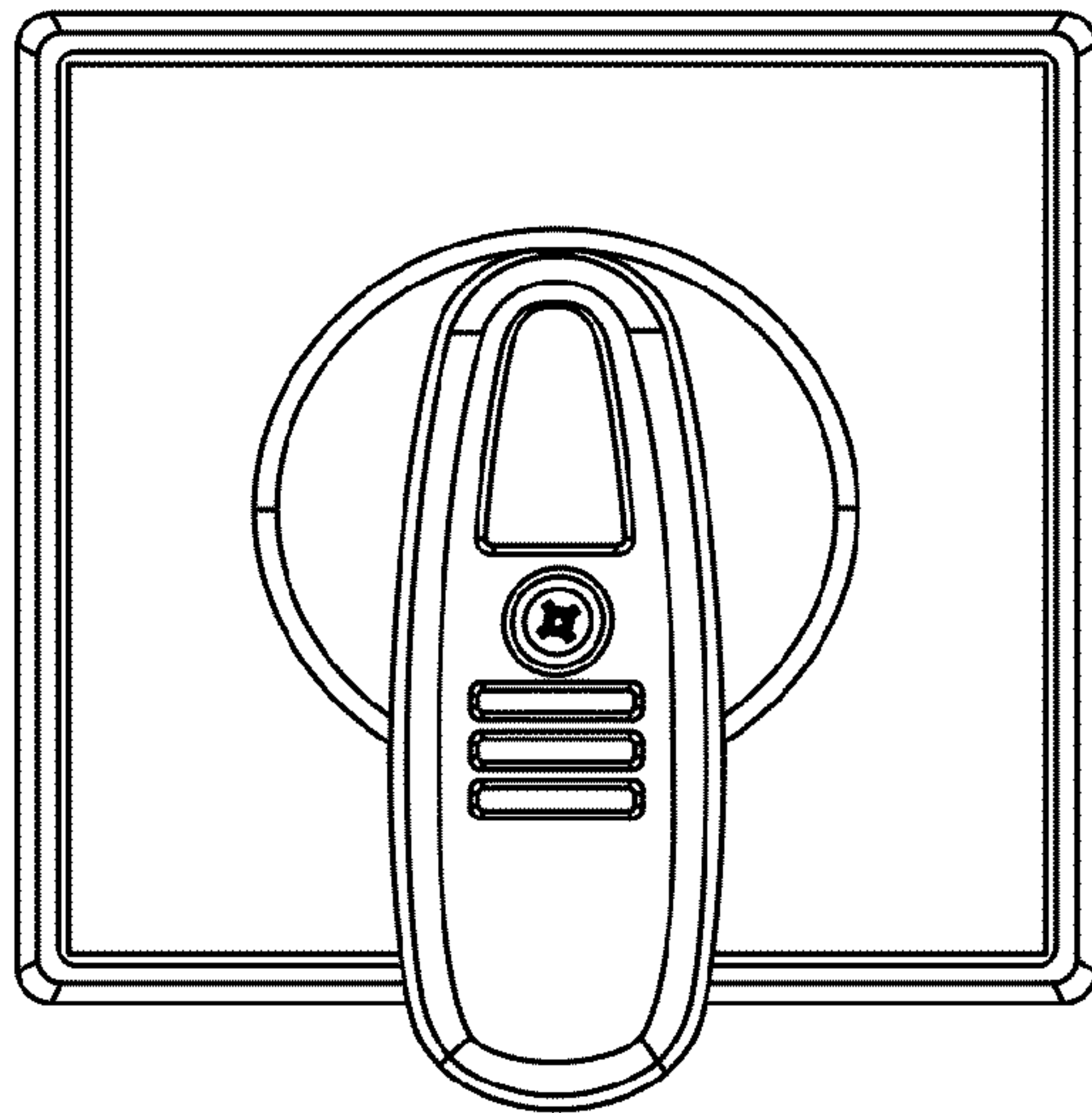

FIG. 9

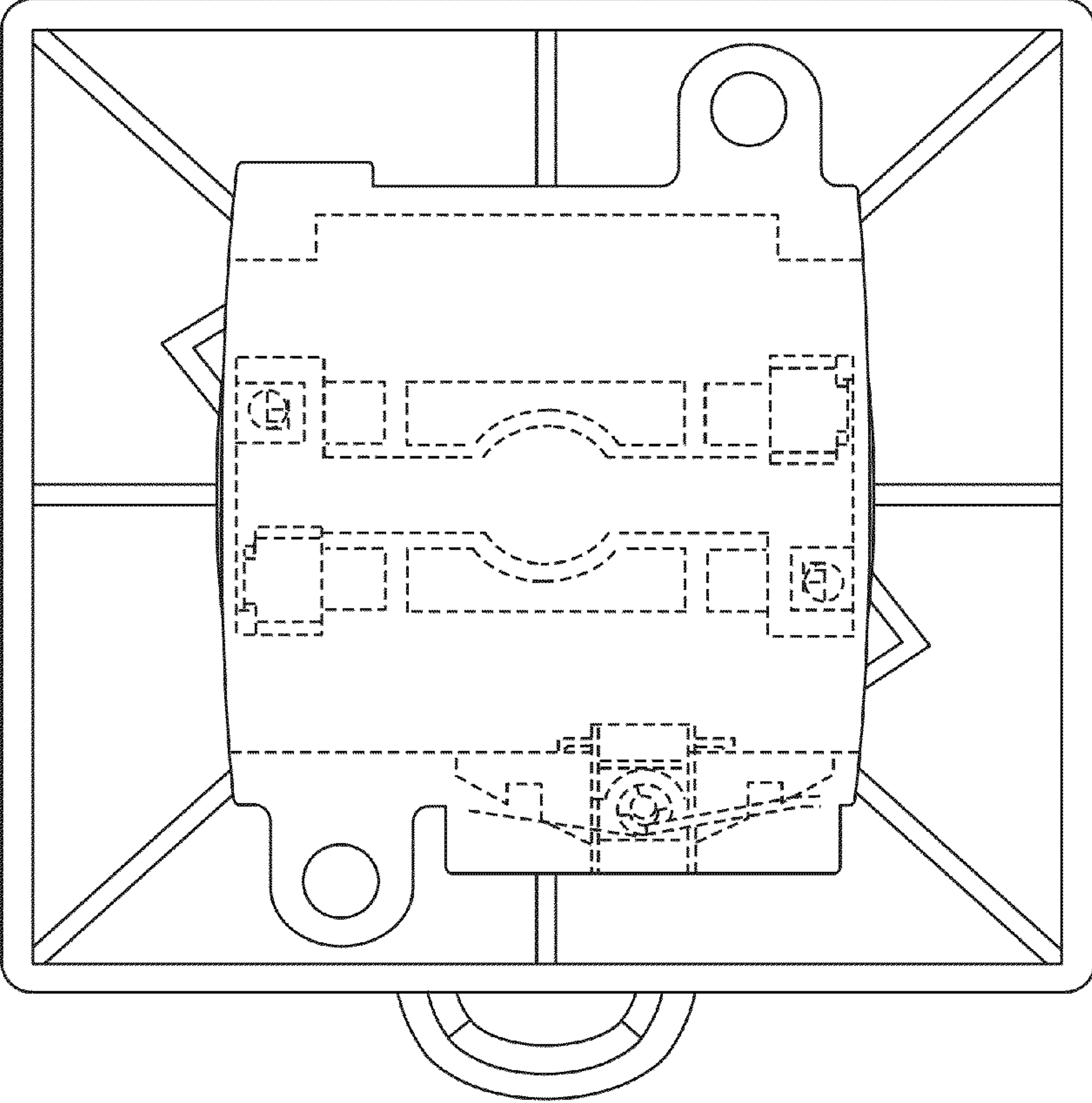

FIG. 10

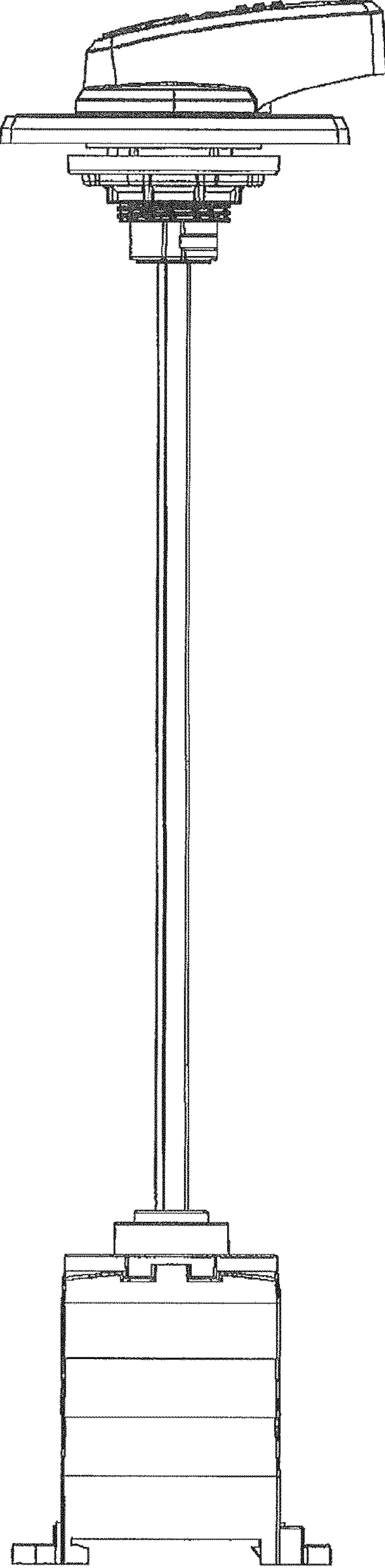

FIG. 11



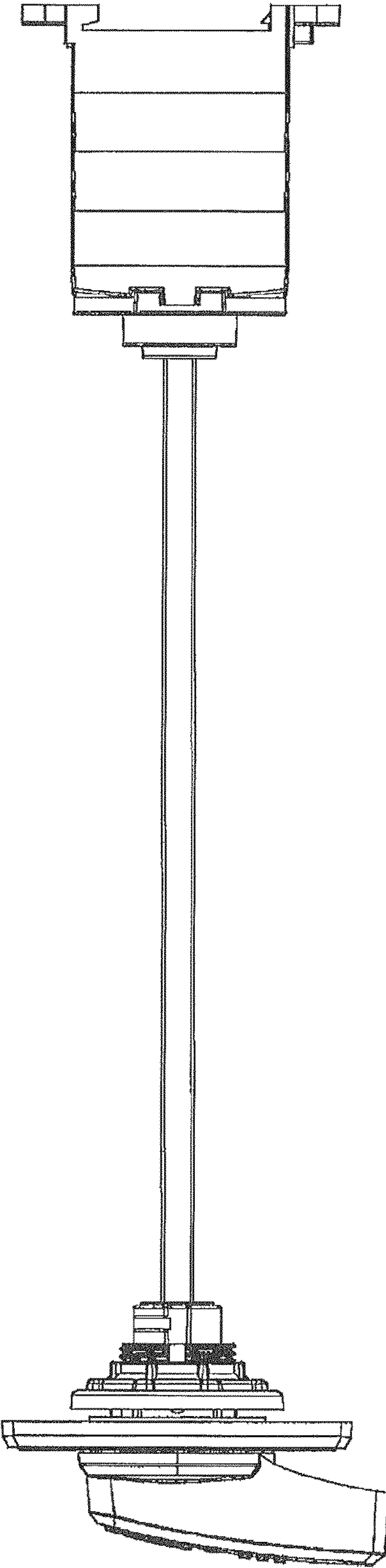

FIG. 12

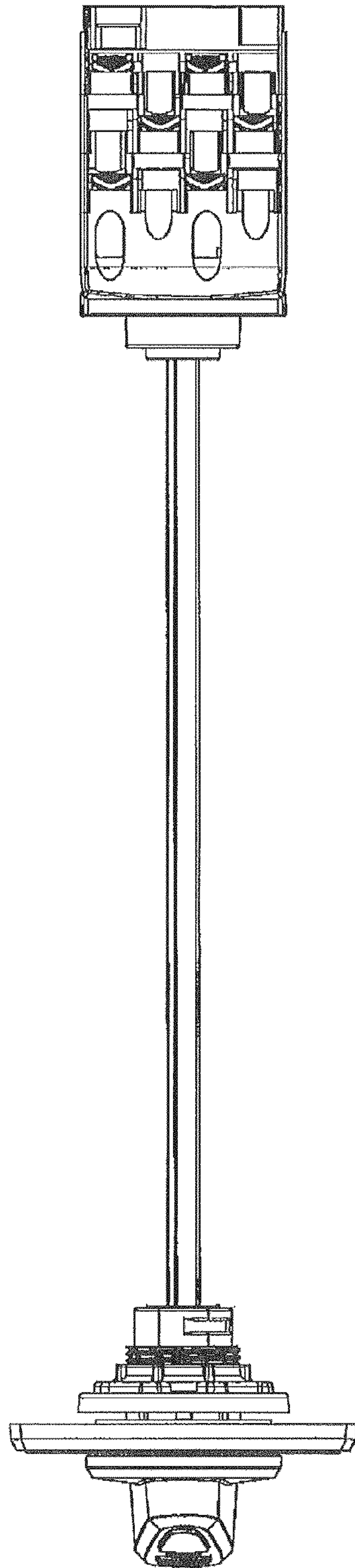

FIG. 13

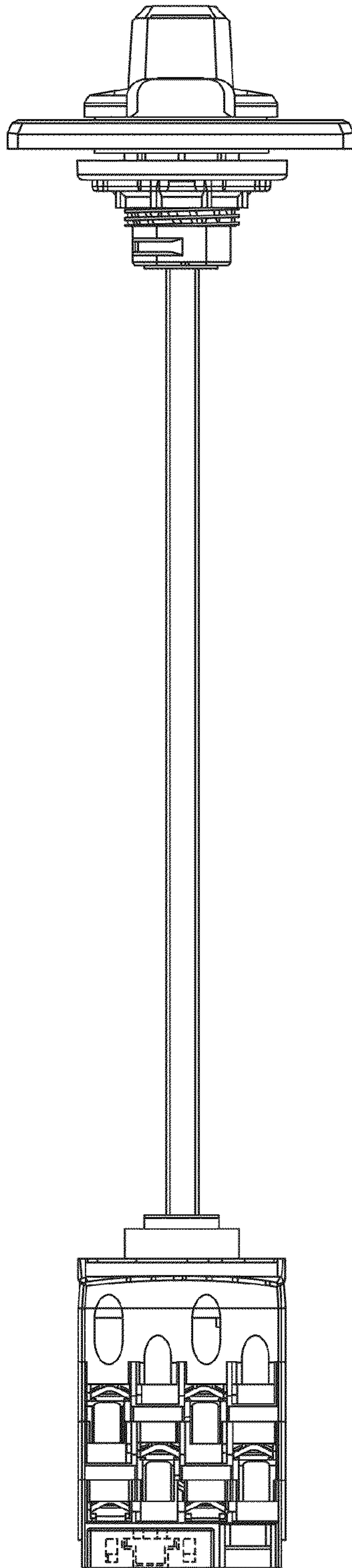

FIG. 14

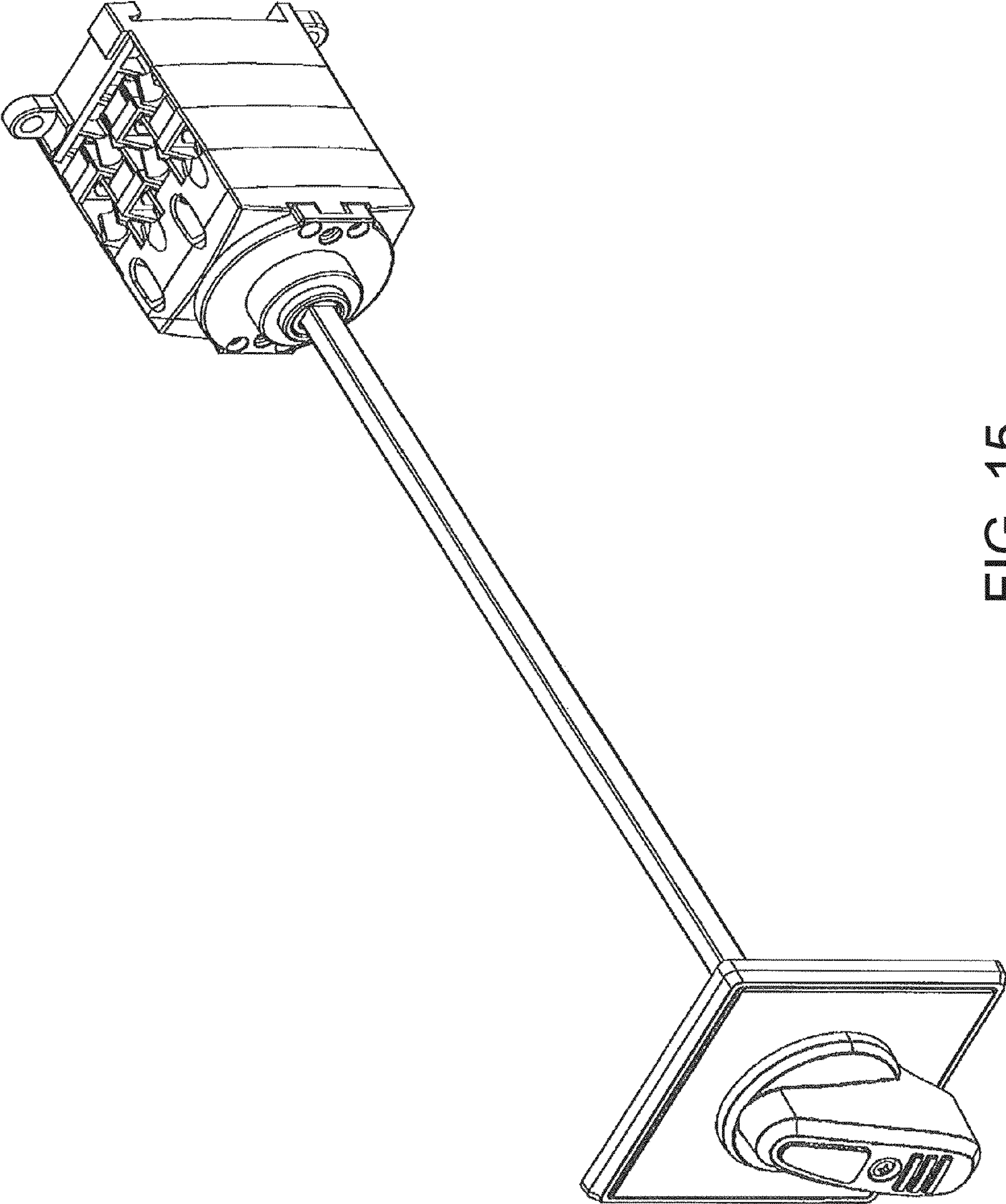

FIG. 15

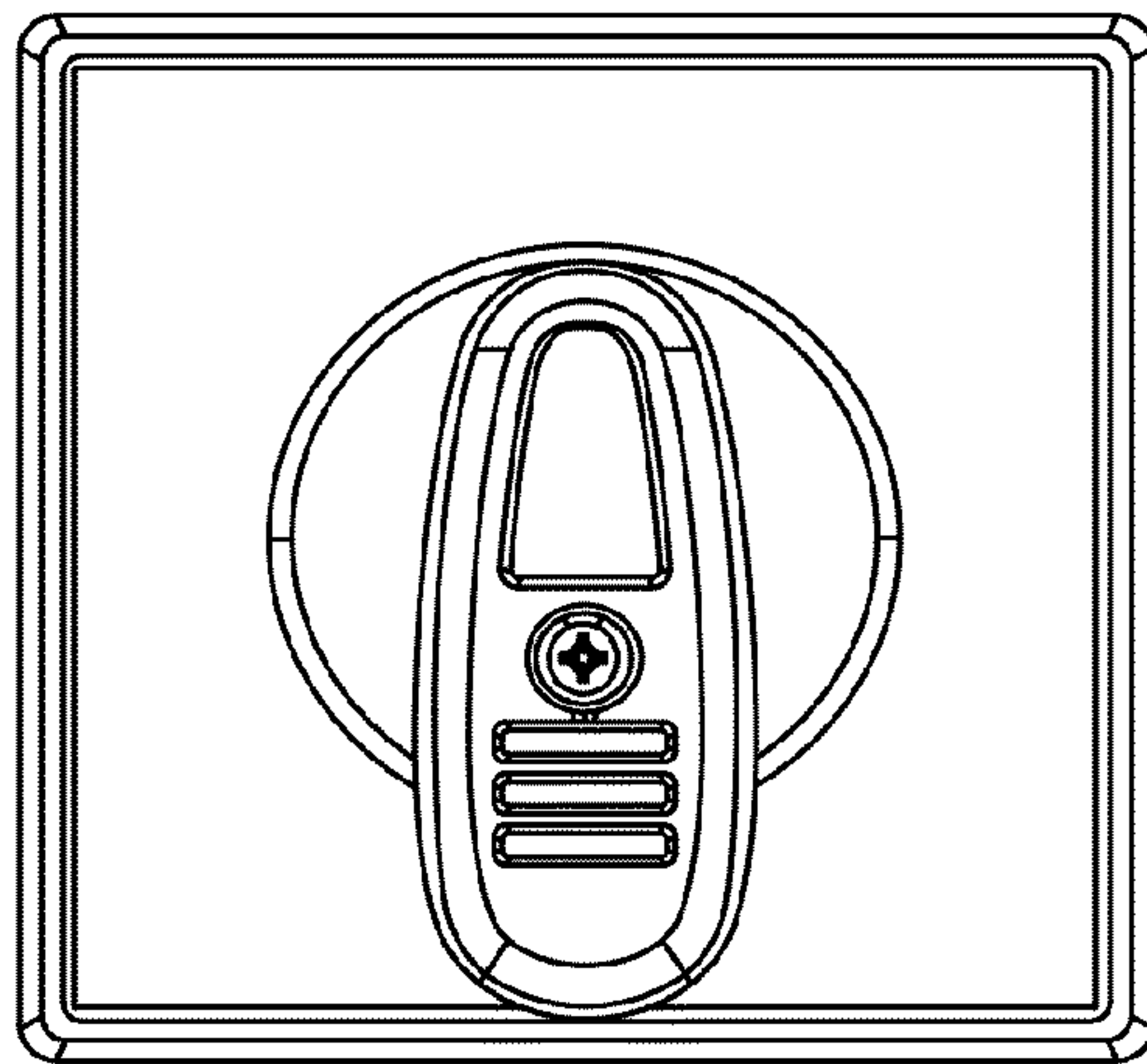

FIG. 16



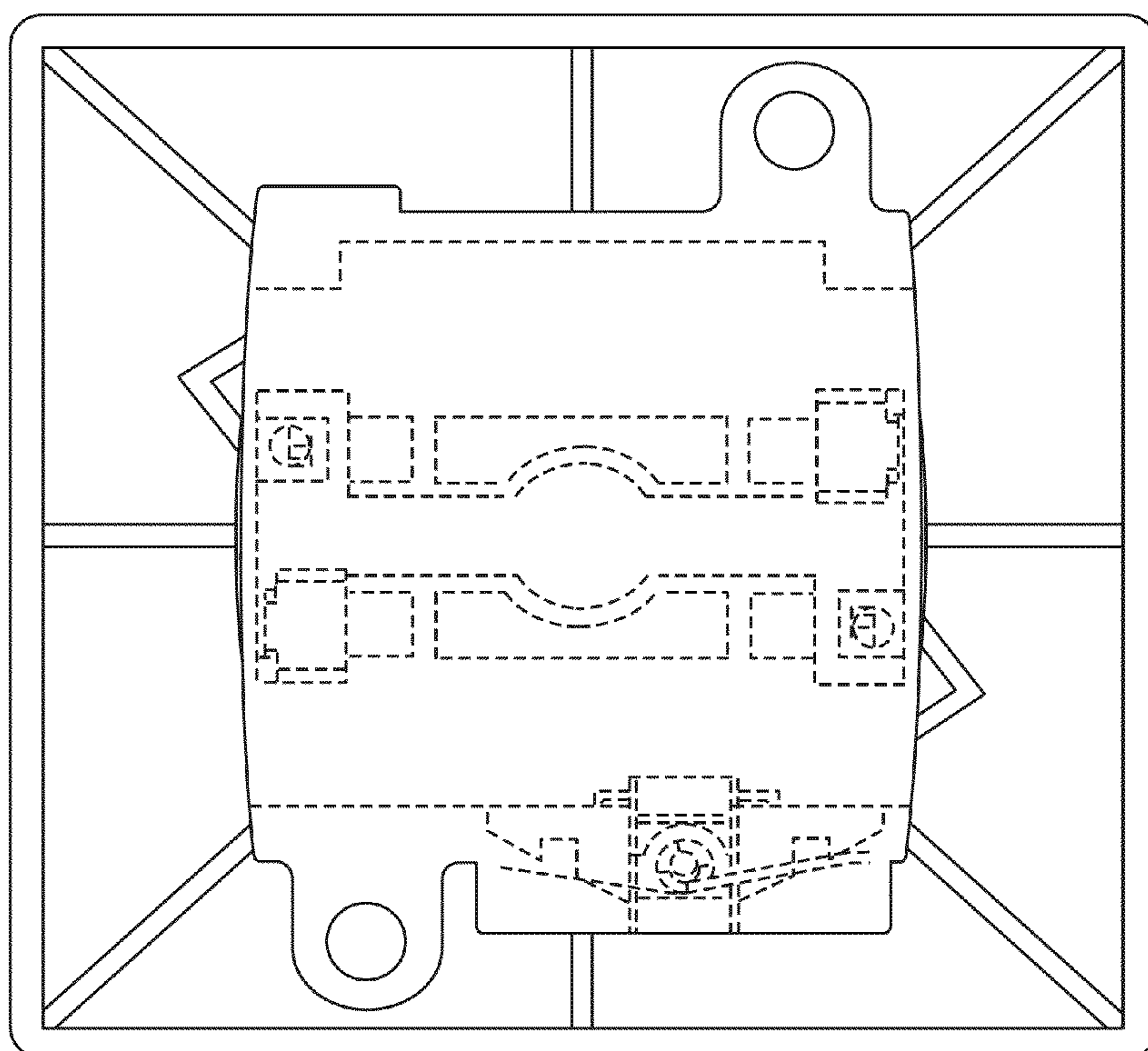

FIG. 17

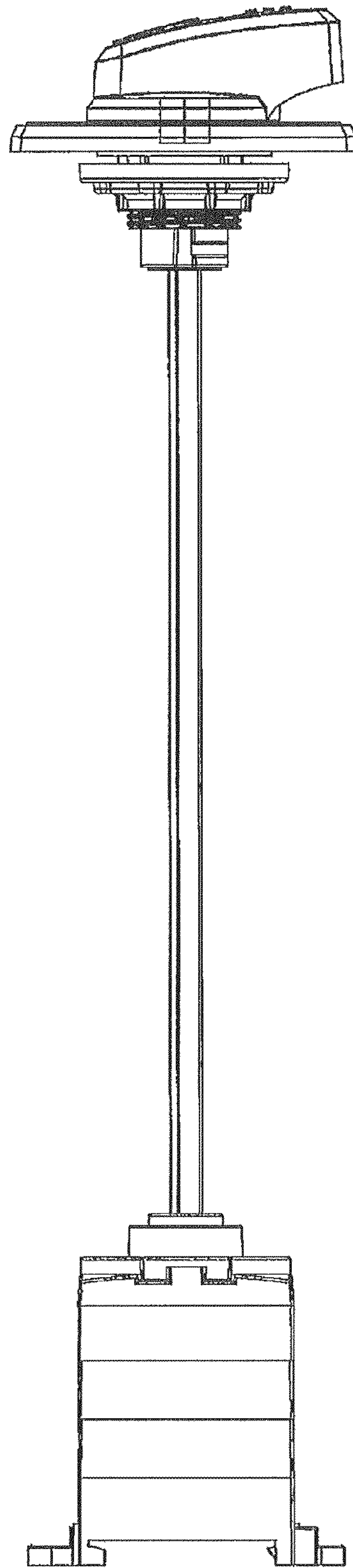

FIG. 18

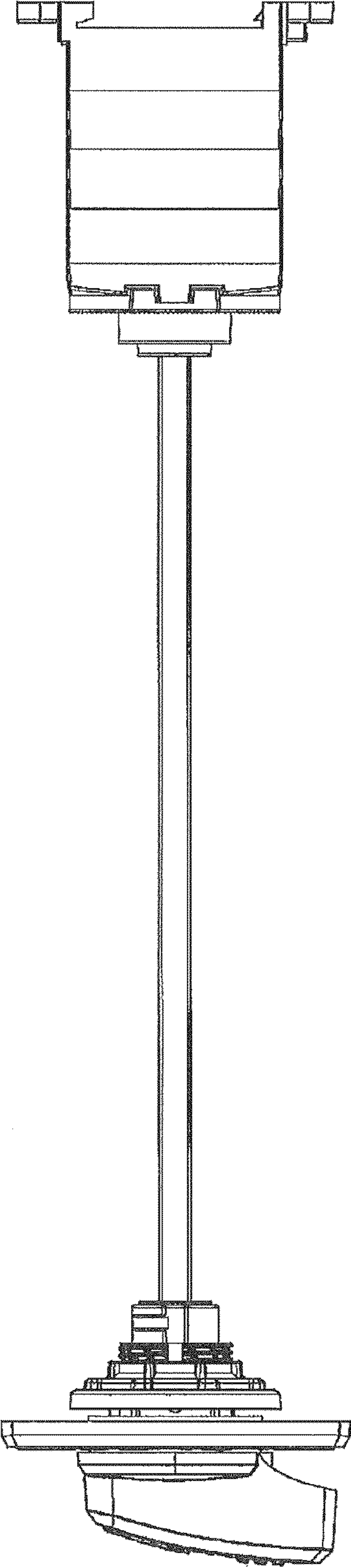

FIG. 19

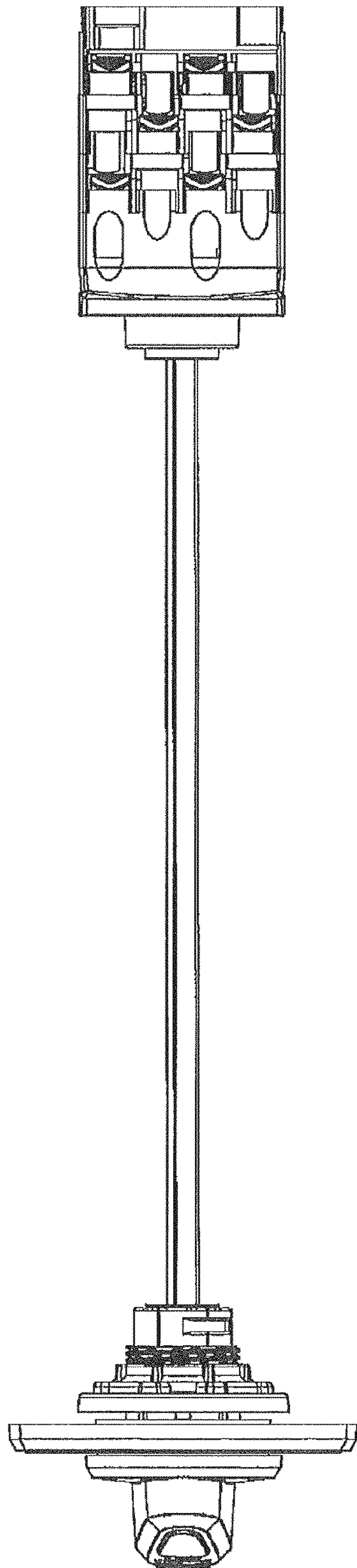

FIG. 20

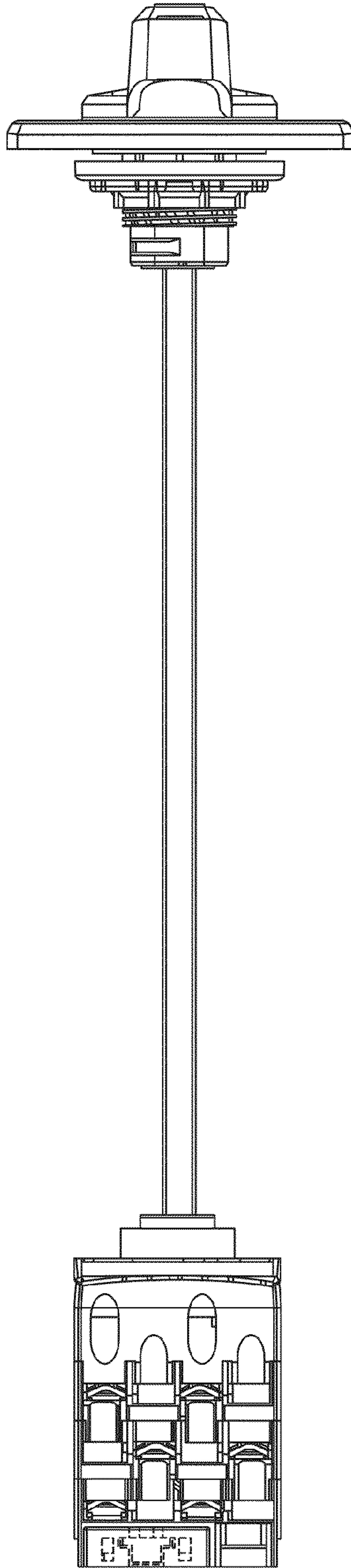

FIG. 21



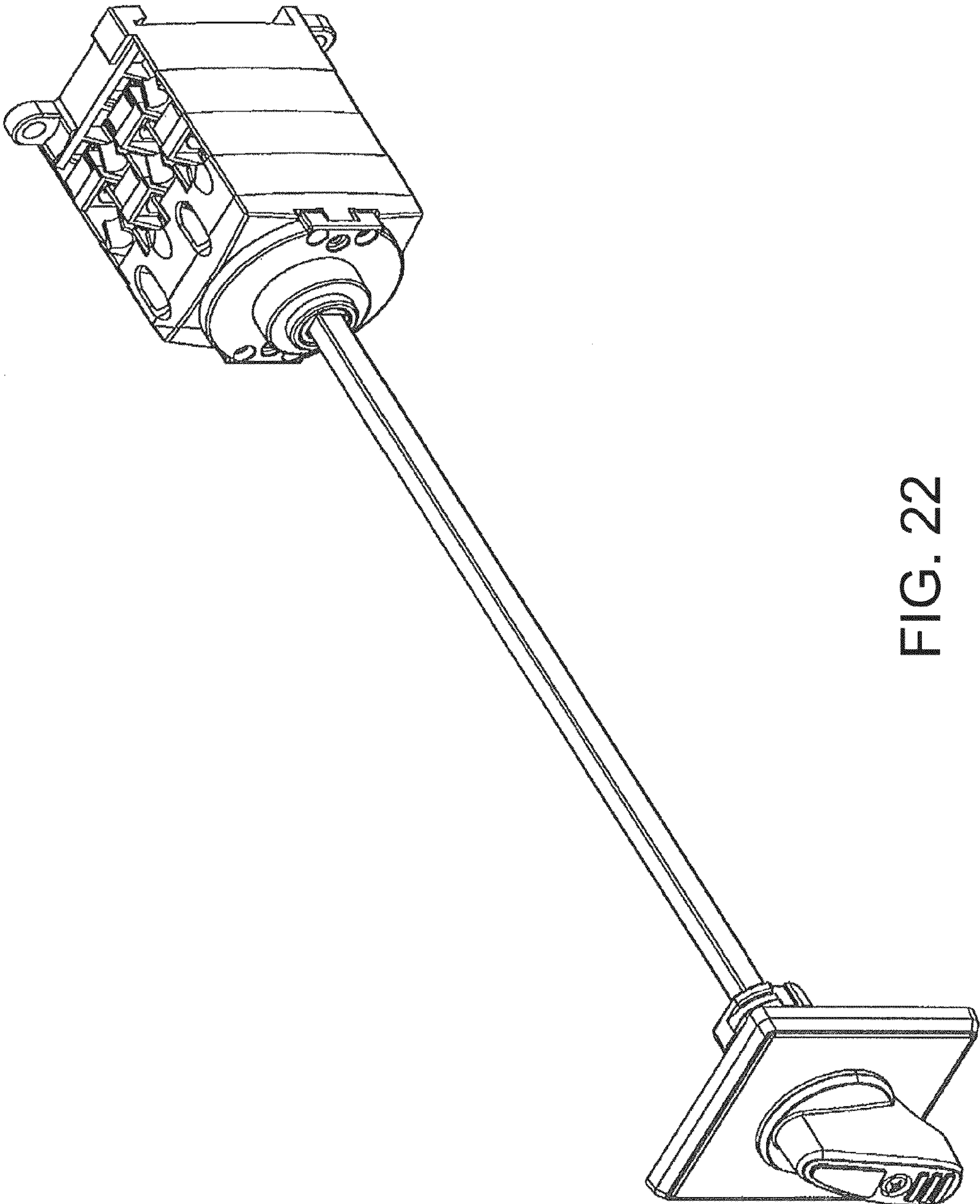

FIG. 22

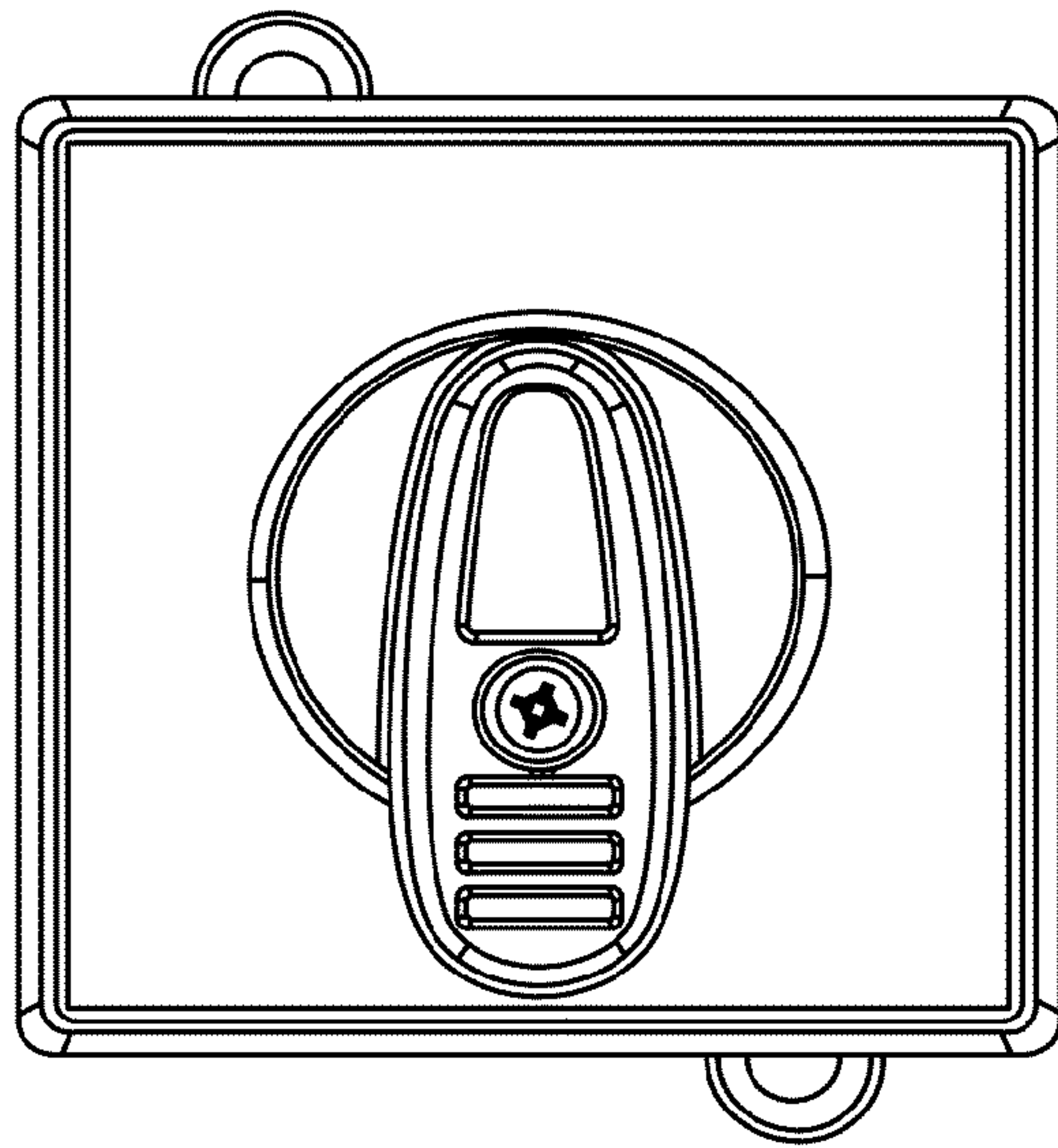

FIG. 23

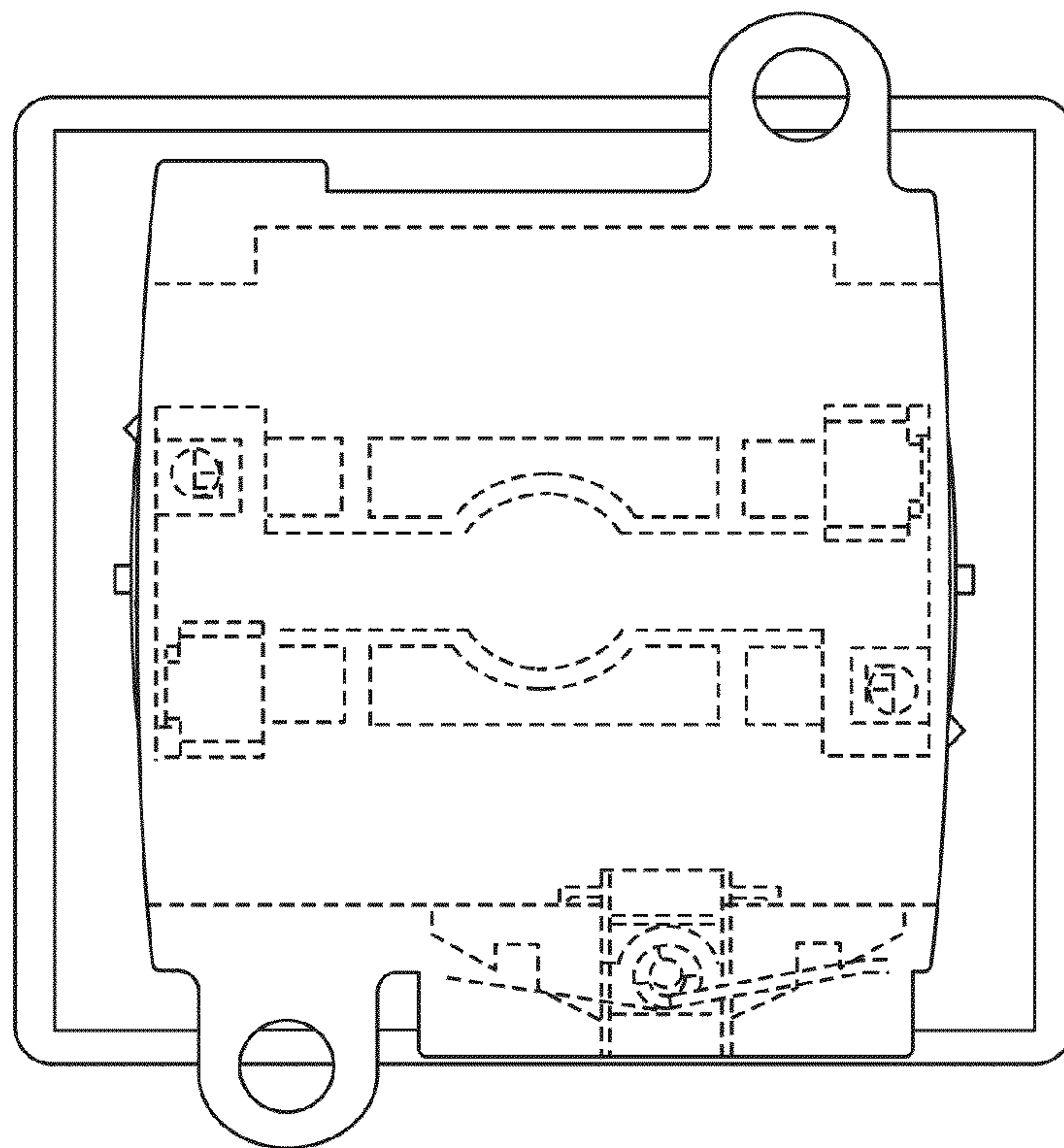

FIG. 24

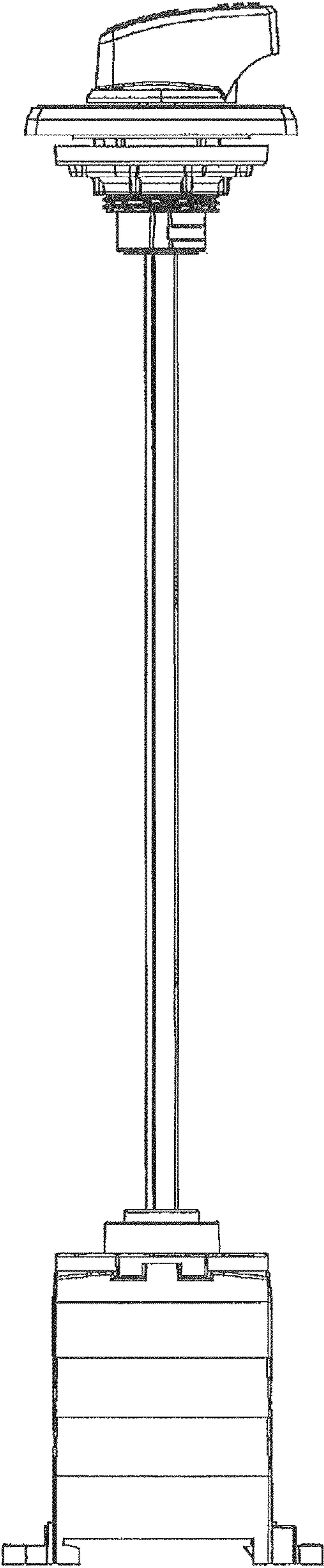

FIG. 25

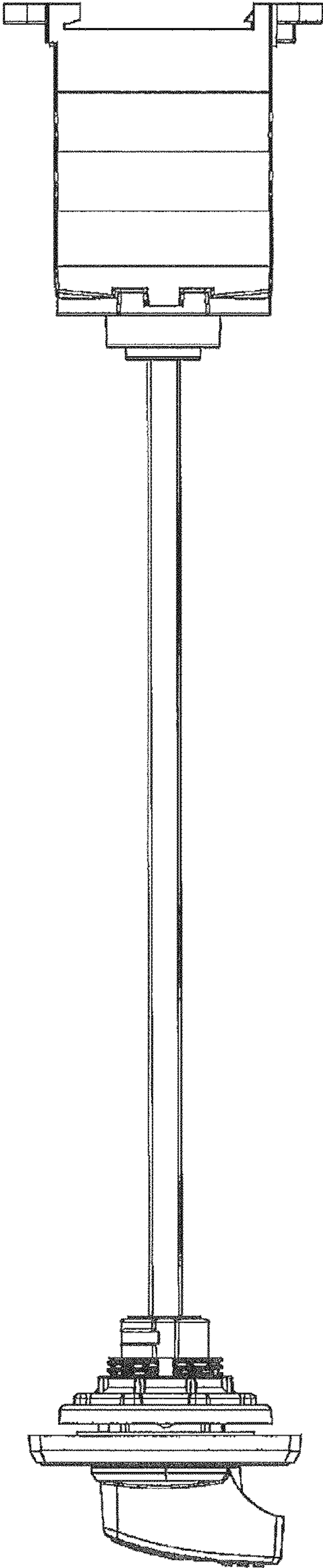

FIG. 26



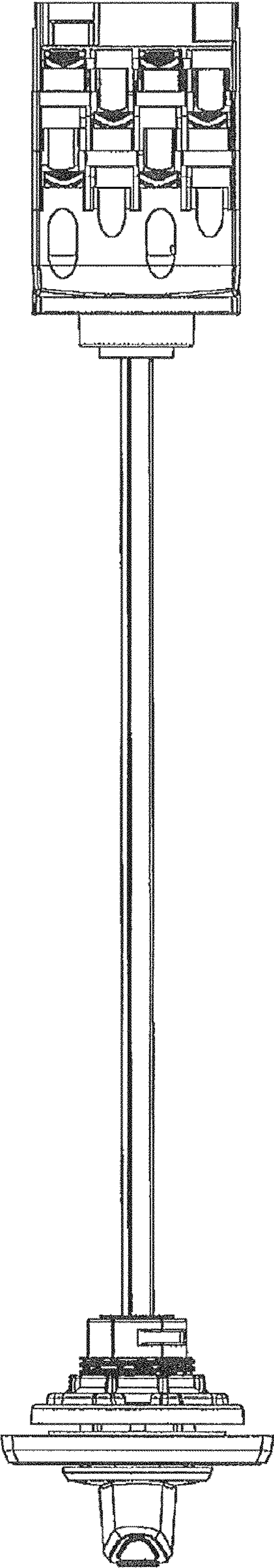

FIG. 27

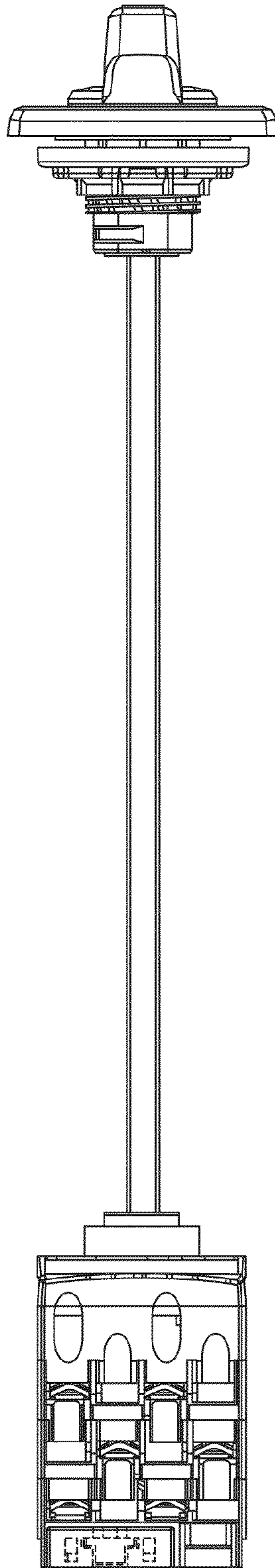

FIG. 28

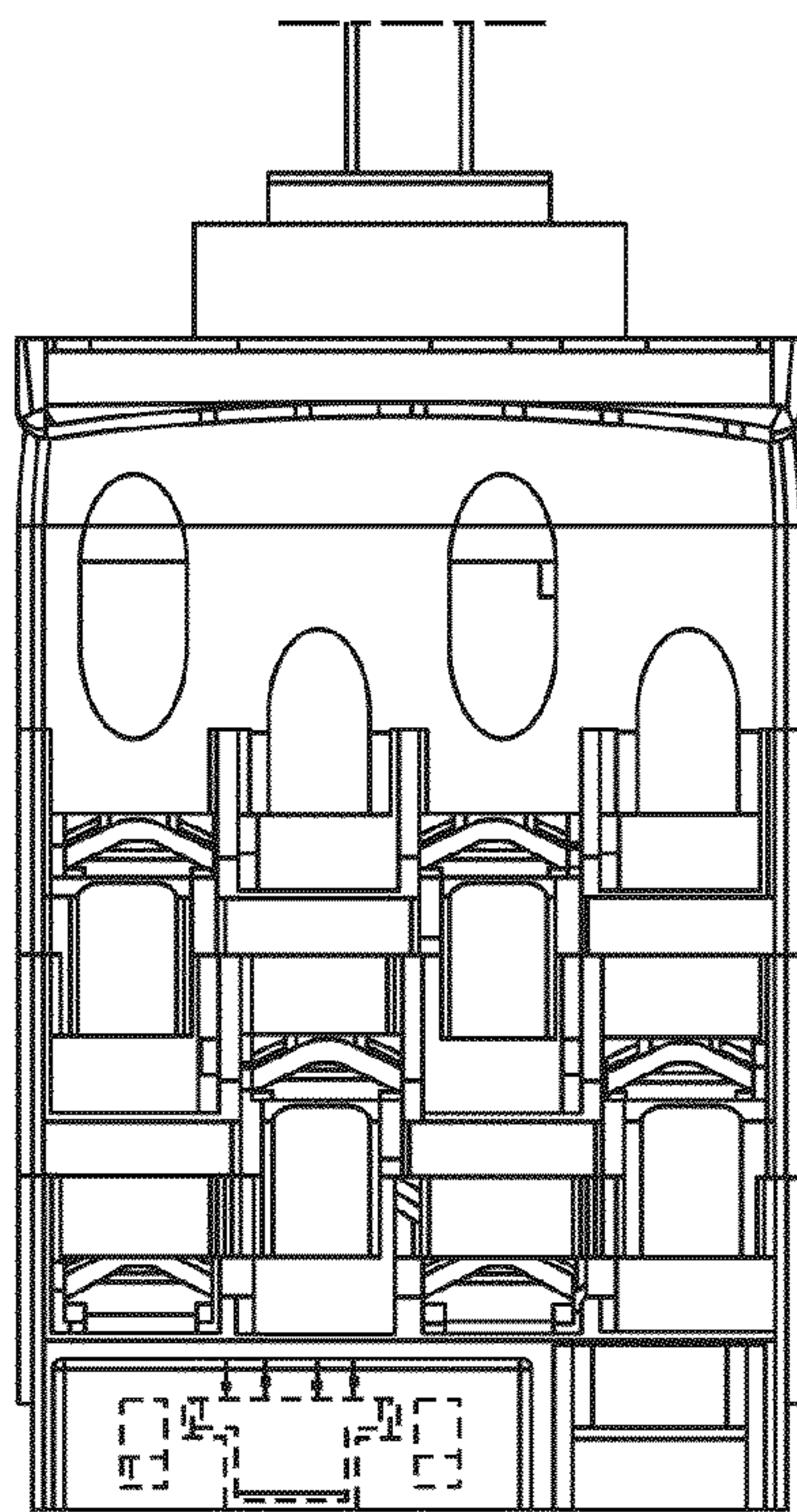

FIG. 29