



US00D756550S

(12) **United States Design Patent**
Sedler

(10) **Patent No.:** **US D756,550 S**

(45) **Date of Patent:** **** May 17, 2016**

(54) **MOTORCYCLE TURN SIGNAL LIGHT**

(71) Applicant: **W. Edward Sedler**, Rochester, NH (US)

(72) Inventor: **W. Edward Sedler**, Rochester, NH (US)

(**) Term: **14 Years**

(21) Appl. No.: **29/511,635**

(22) Filed: **Dec. 12, 2014**

(51) **LOC (10) Cl.** **26-06**

(52) **U.S. Cl.**
USPC **D26/28**

(58) **Field of Classification Search**
USPC D26/28-36; 362/61, 80-83, 459-468,
362/475-478, 485-487
CPC F21S 48/00; F21S 48/10; F21S 48/115;
B62J 6/00; B62J 6/02; B61L 15/02; B60Q
1/34; B60Q 1/305
See application file for complete search history.

(56) **References Cited**

U.S. PATENT DOCUMENTS

D455,852 S	*	4/2002	Sawabe	D26/28
D499,824 S	*	12/2004	Wu	D26/28
D501,571 S	*	2/2005	Kouchi	D26/28
D511,016 S	*	10/2005	Tamura	D26/28
D517,708 S	*	3/2006	Phillips	D26/28
D518,207 S	*	3/2006	Wong	D26/28

D587,827 S	*	3/2009	Tsukui	D26/28
D590,079 S	*	4/2009	Higashikawa	D26/28
D592,328 S	*	5/2009	Chen	D26/28
D593,234 S	*	5/2009	Matsumura	D26/30
D602,184 S	*	10/2009	Wu	D26/28

* cited by examiner

Primary Examiner — Marcus Jackson

(74) *Attorney, Agent, or Firm* — Jonathan B. Witcomb;
Sheehan Phinney Bass & Green Pa

(57) **CLAIM**

I claim the ornamental design for a motorcycle turn signal light, as shown and described.

DESCRIPTION

FIG. 1 is a front perspective view of a motorcycle turn signal light of the present invention as mounted on a motorcycle; FIG. 2 is an isolated front perspective view of the motorcycle turn signal light of the present invention; FIG. 3 is a front view of the motorcycle turn signal light; FIG. 4 is a top view of the motorcycle turn signal light; FIG. 5 is a left view of the motorcycle turn signal light; FIG. 6 is a right side view of the motorcycle turn signal light; FIG. 7 is a rear view of the motorcycle turn signal light; and, FIG. 8 is a bottom view of the motorcycle turn signal light. The broken lines in FIGS. 1-3 and 5-8 are included for the purpose of showing environmental structure that forms no part of the design.

1 Claim, 4 Drawing Sheets

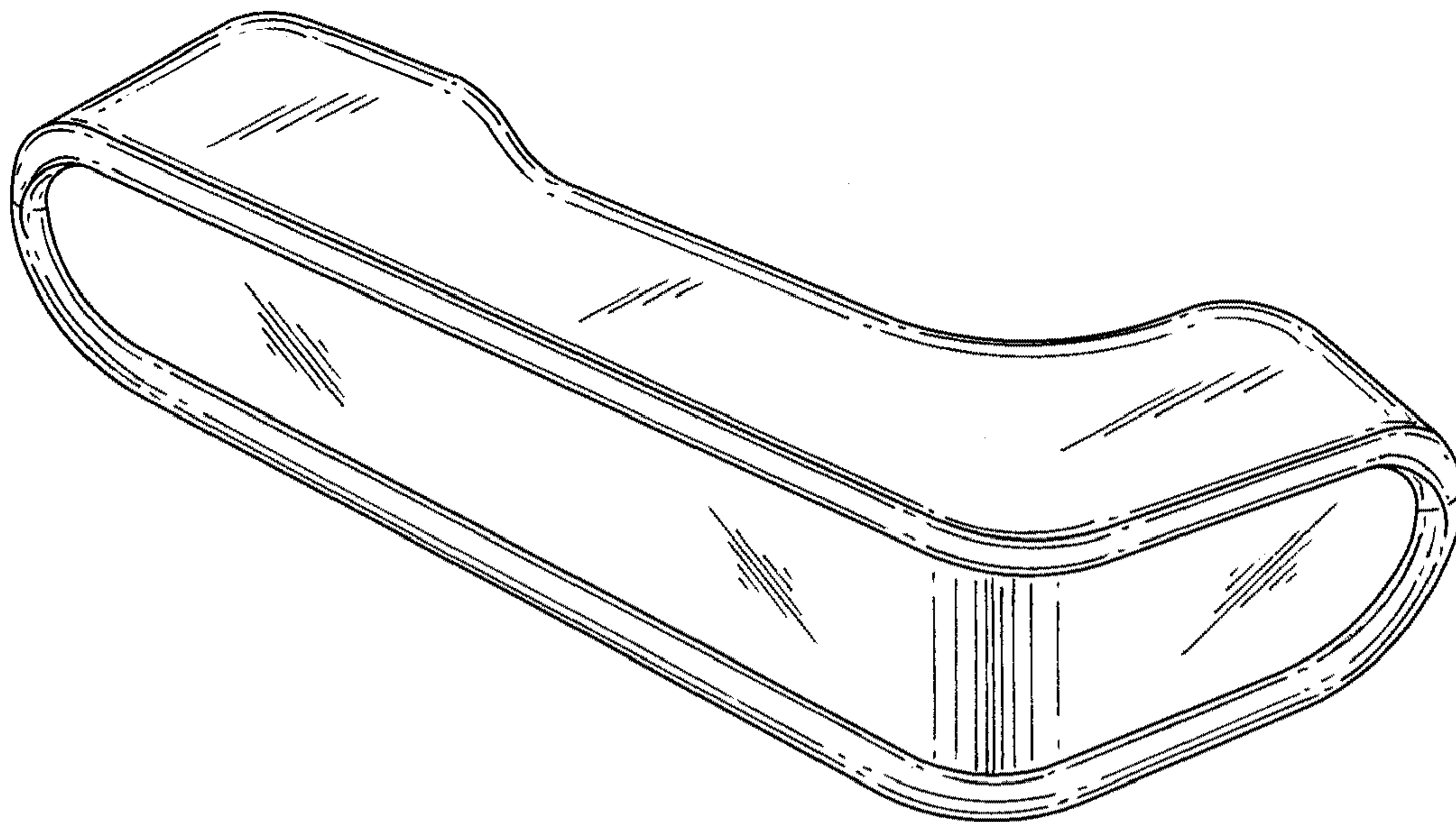

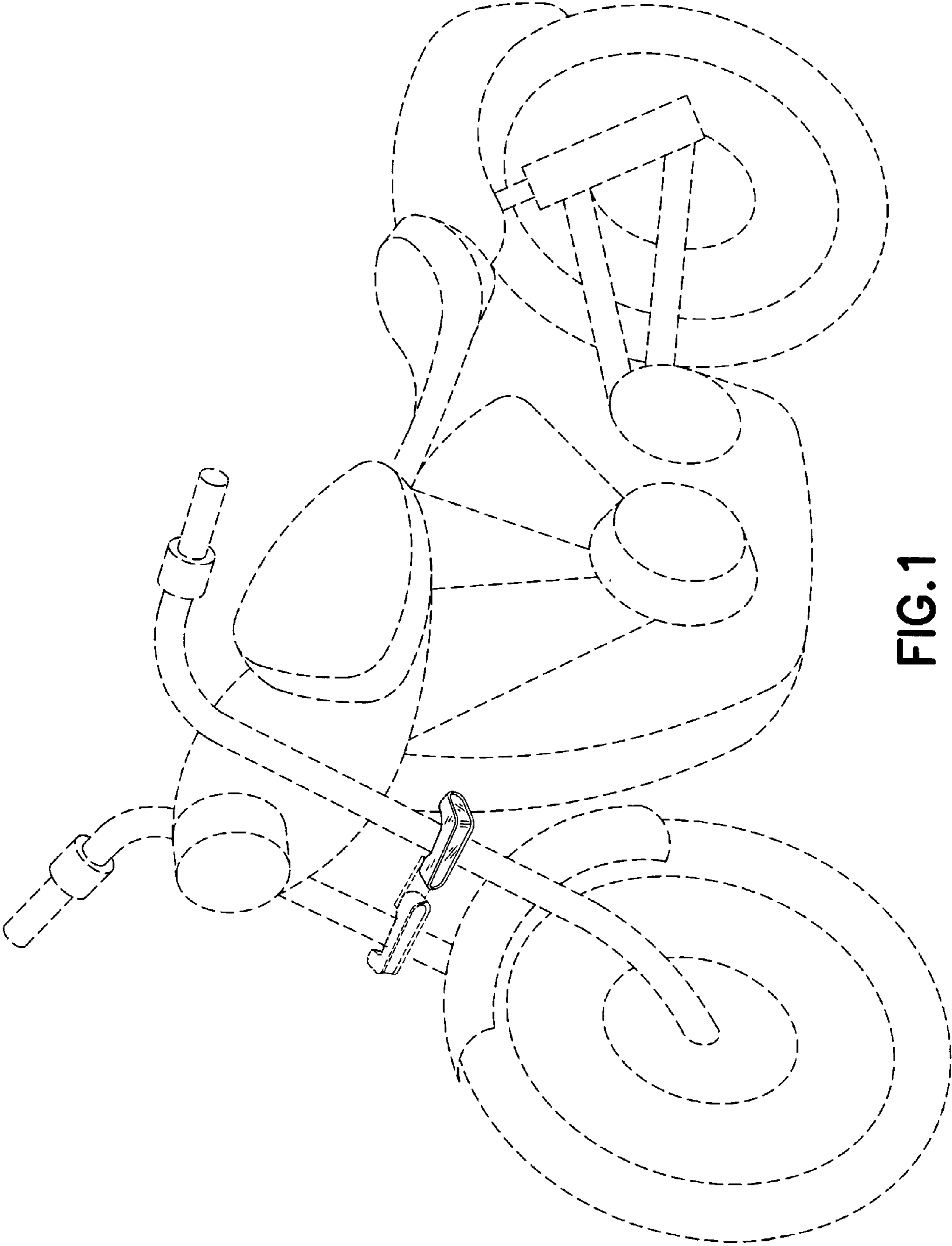

FIG.1

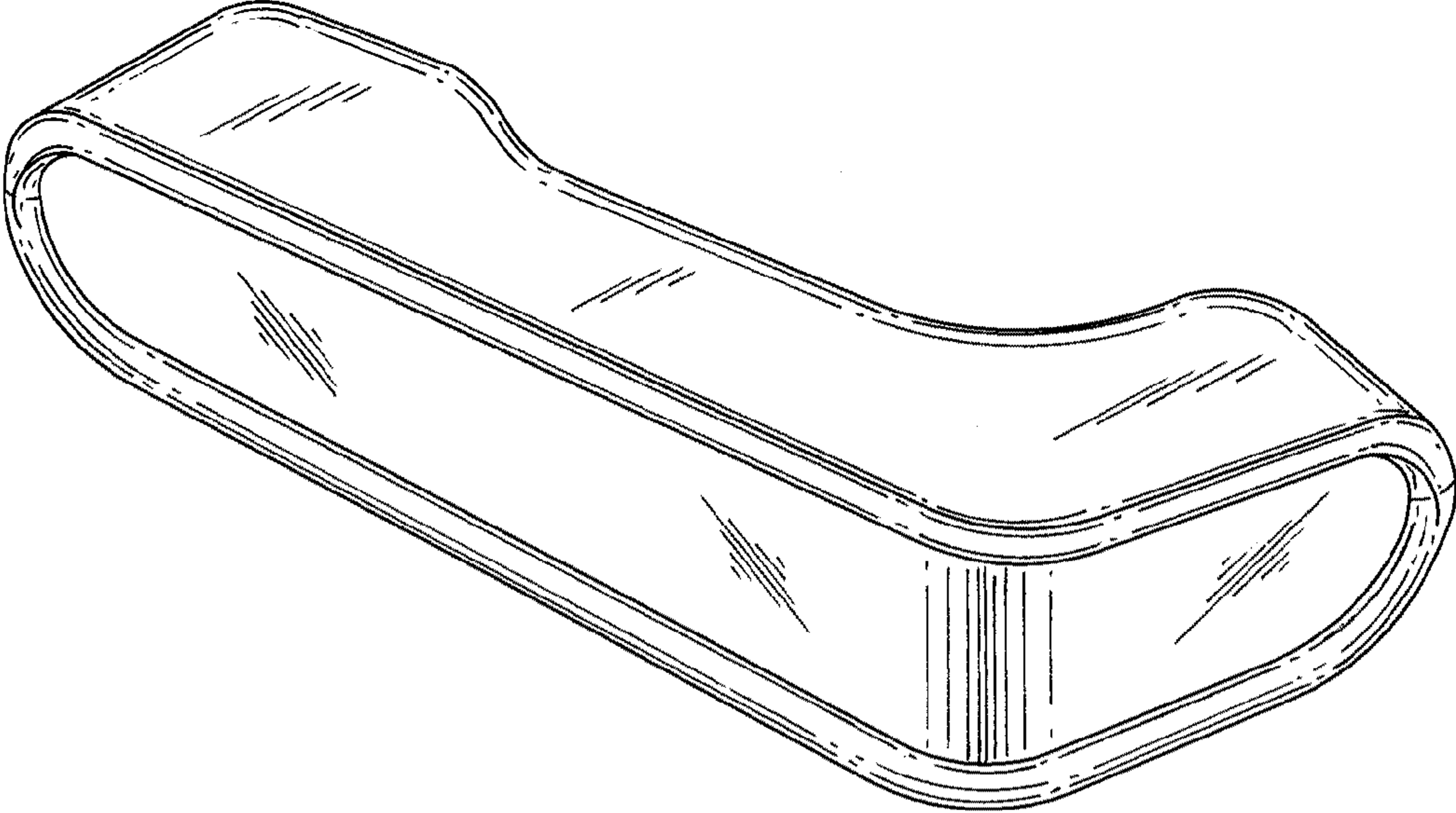

FIG. 2

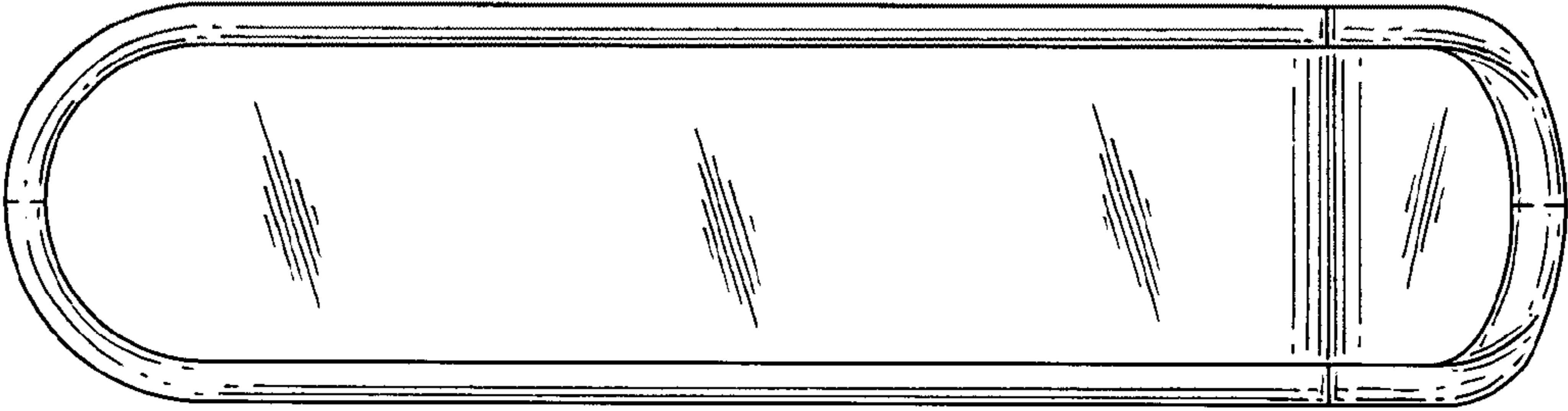

FIG. 3

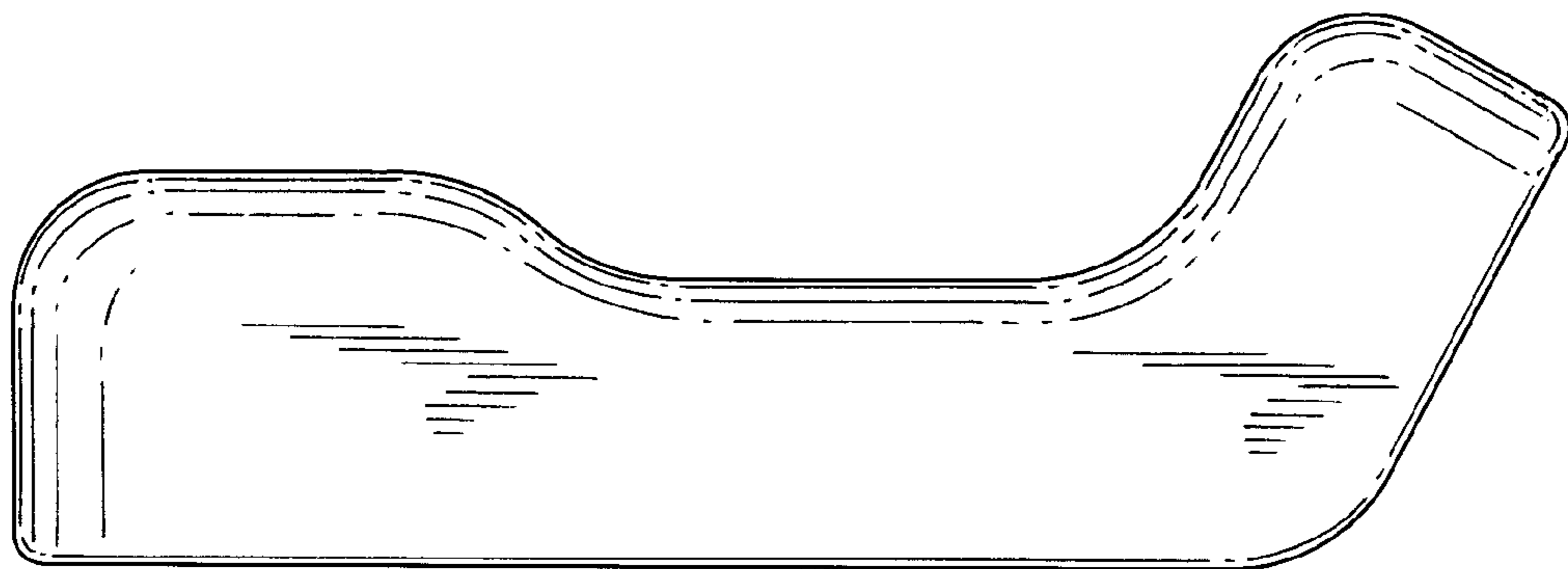

FIG. 4

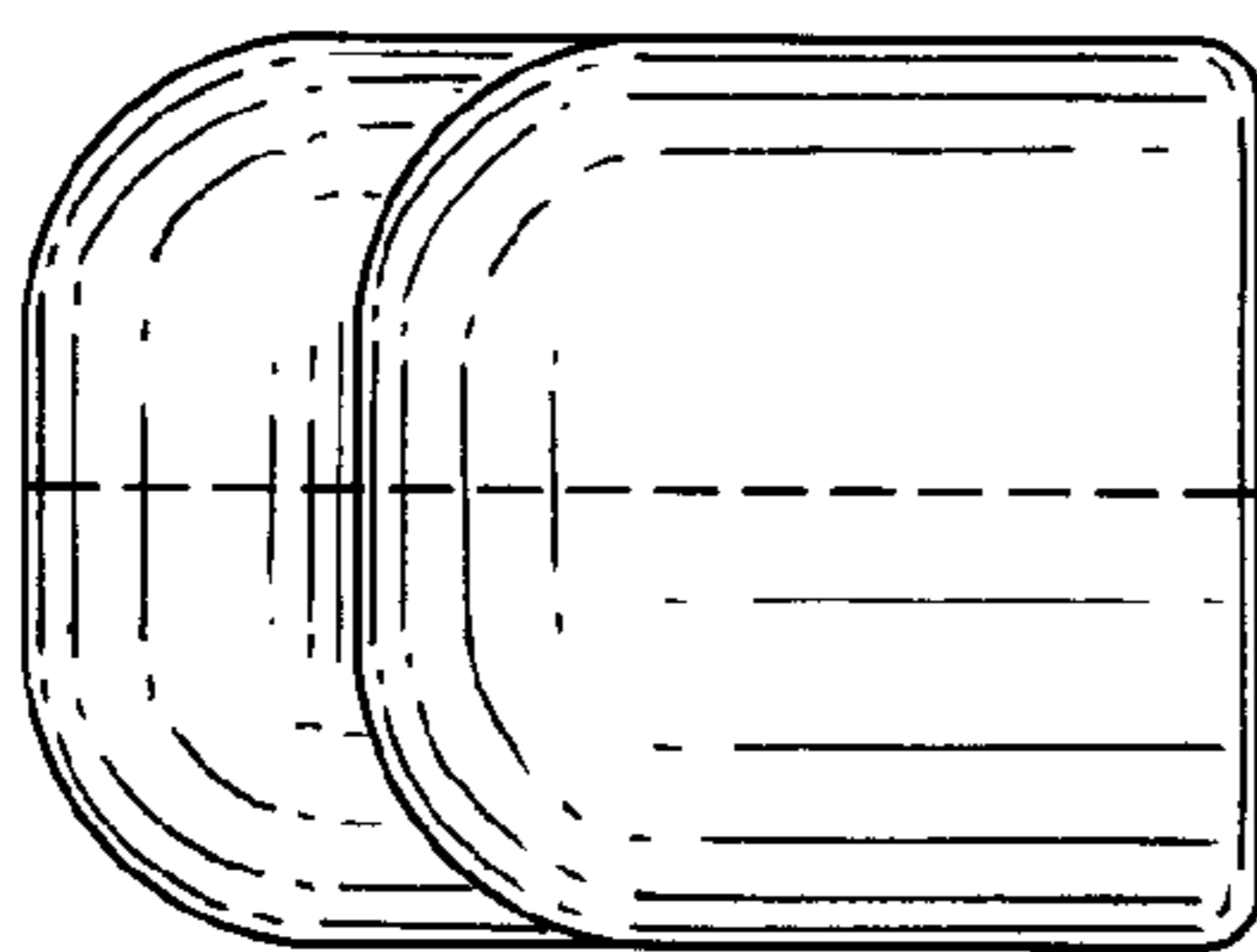

FIG. 5

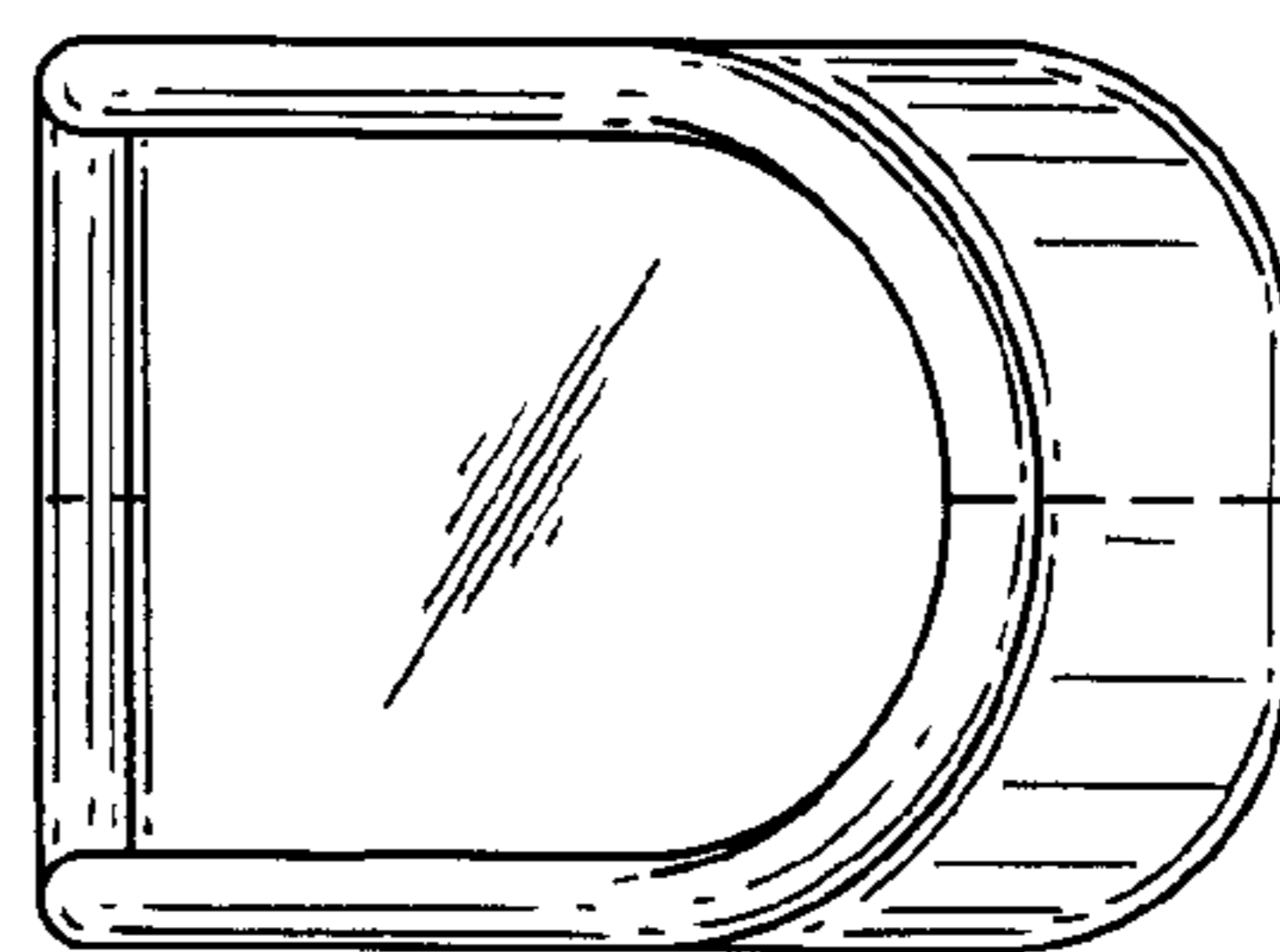

FIG. 6

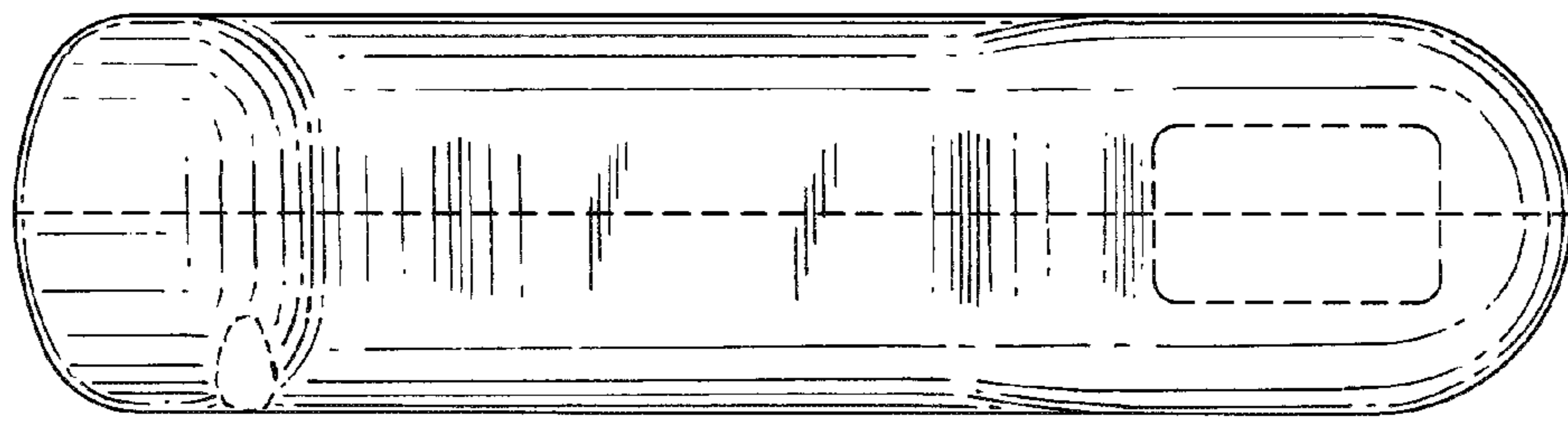

FIG. 7

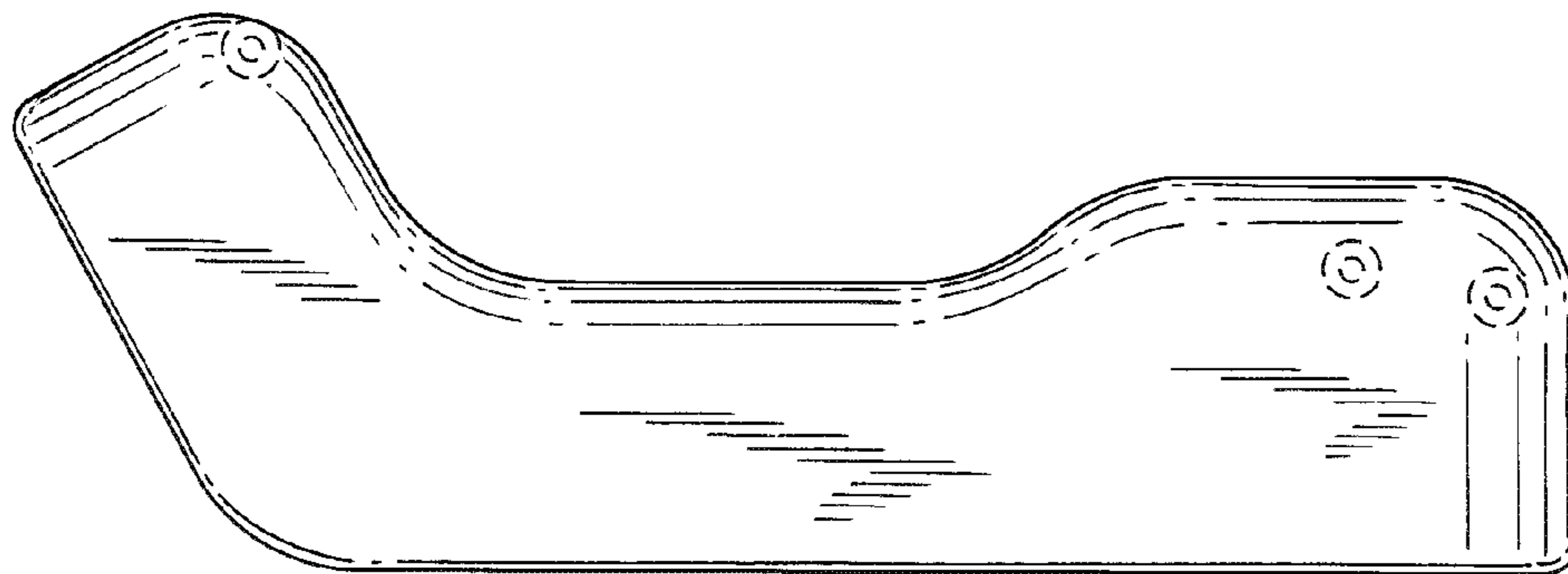

FIG. 8