



US00D756322S

(12) **United States Design Patent**
Østensen et al.

(10) **Patent No.:** **US D756,322 S**
(45) **Date of Patent:** **** May 17, 2016**

(54) **VIDEO CONFERENCE SYSTEM ENDPOINT**

(71) Applicant: **Cisco Technology, Inc.**, San Jose, CA
(US)

(72) Inventors: **Kristian Magnus Østensen**, Oslo (NO);
Vidar Borthne, Oslo (NO); **Torkel Mellingen**, Oslo (NO)

(73) Assignee: **Cisco Technology, Inc.**, San Jose, CA
(US)

(**) Term: **15 Years**

(21) Appl. No.: **29/540,191**

(22) Filed: **Sep. 22, 2015**

Related U.S. Application Data

(62) Division of application No. 29/481,377, filed on Feb. 5, 2014, now Pat. No. Des. 742,845.

(51) **LOC (10) Cl.** **14-03**

(52) **U.S. Cl.**
USPC **D14/126**

(58) **Field of Classification Search**
USPC D14/125–134, 239, 371, 136, 374–377,
D14/440, 450, 448, 336, 342, 159; 312/7.2;
348/836, 838, 180, 184, 325, 739;
248/917–924, 465; 345/104, 133, 156,
345/168, 87, 173; D21/329, 515, 577, 622,
D21/333, 433, 448, 452, 450, 331, 505;
D10/15, 26; 446/484, 175, 356;
D6/477, 479, 300; D24/185; D34/14
CPC ... G06F 1/1601; G06F 1/1643; H05K 5/0004;
H05K 5/0017; H05K 5/02; H05K 5/0217
See application file for complete search history.

(56) **References Cited**

U.S. PATENT DOCUMENTS

D540,762 S * 4/2007 Lunde D14/129
D615,054 S * 5/2010 Mellingen et al. D14/127

D623,619 S * 9/2010 Roed et al. D14/126
D636,359 S 4/2011 Buzzard et al.
D636,747 S 4/2011 Buzzard et al.
D637,568 S 5/2011 Desai et al.
D637,570 S 5/2011 Desai et al.
D653,245 S 1/2012 Buzzard et al.
D655,279 S 3/2012 Buzzard et al.
D682,293 S * 5/2013 Kanalakis et al. D14/487
8,542,264 B2 * 9/2013 Lu et al. 348/14.08
D708,158 S * 7/2014 Minyard D14/127
D718,260 S * 11/2014 Mellingen et al. D14/126
D720,317 S * 12/2014 Kamp et al. D14/126
D732,496 S * 6/2015 Mellingen et al. D14/126

* cited by examiner

Primary Examiner — Randall Gholson

(74) *Attorney, Agent, or Firm* — Edell, Shapiro, Finnan, LLC

(57) **CLAIM**

The ornamental design for a video conference system endpoint, as shown and described.

DESCRIPTION

FIG. 1 is a front perspective view of a video conference system endpoint;
FIG. 2 is a rear perspective view of the video conference system endpoint of FIG. 1;
FIG. 3 is a front elevation view of the video conference system endpoint of FIG. 1;
FIG. 4 is a rear elevation view of the video conference system endpoint of FIG. 1;
FIG. 5 is a first side elevation view of the video conference system endpoint of FIG. 1;
FIG. 6 is a second side elevation view the video conference system endpoint of FIG. 1;
FIG. 7 is a top plan view of the video conference system endpoint of FIG. 1; and,
FIG. 8 is a bottom plan view the video conference system endpoint of FIG. 1.
The broken lines depict portions of the video conference system endpoint that form no part of the claimed design.

1 Claim, 4 Drawing Sheets

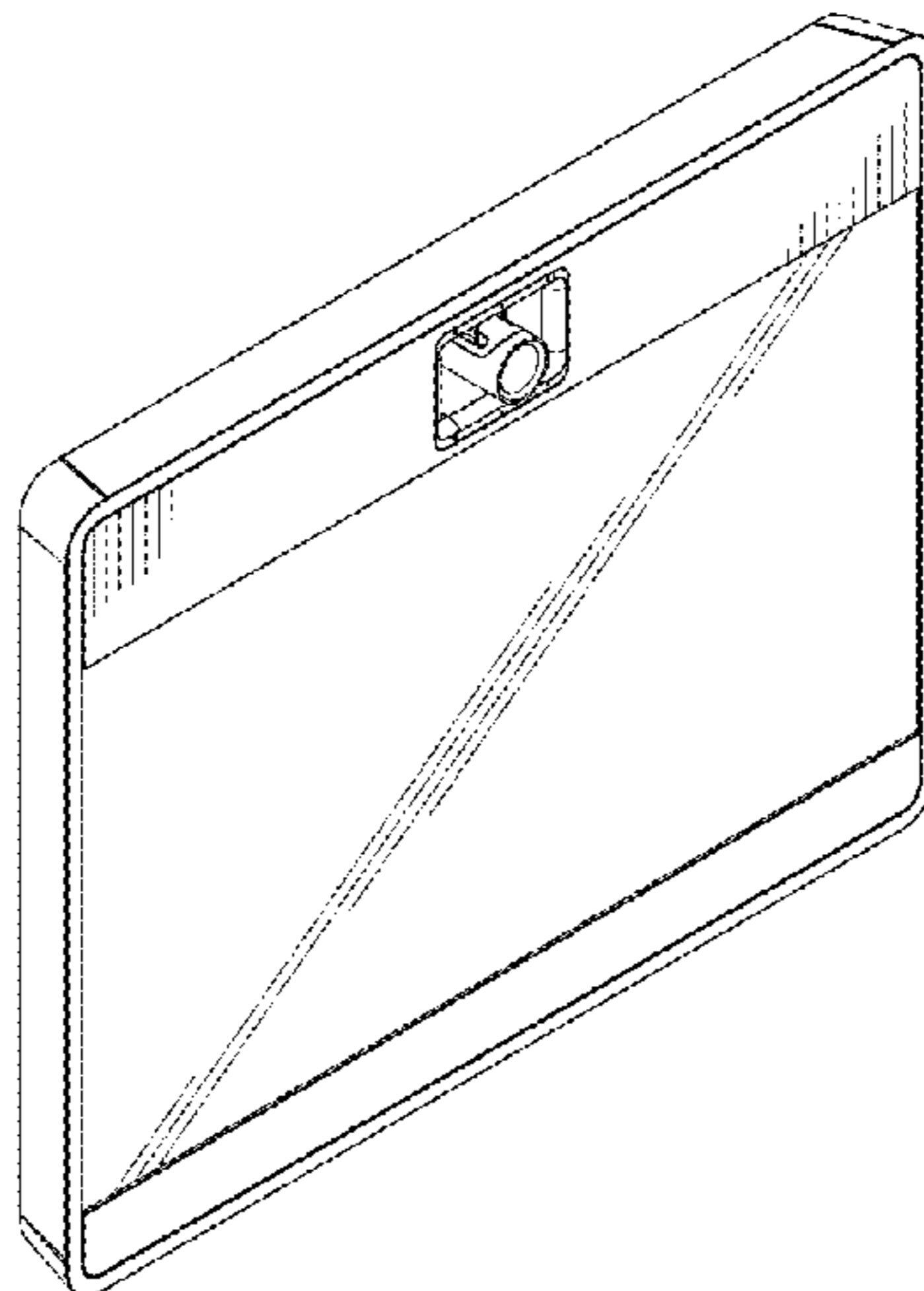

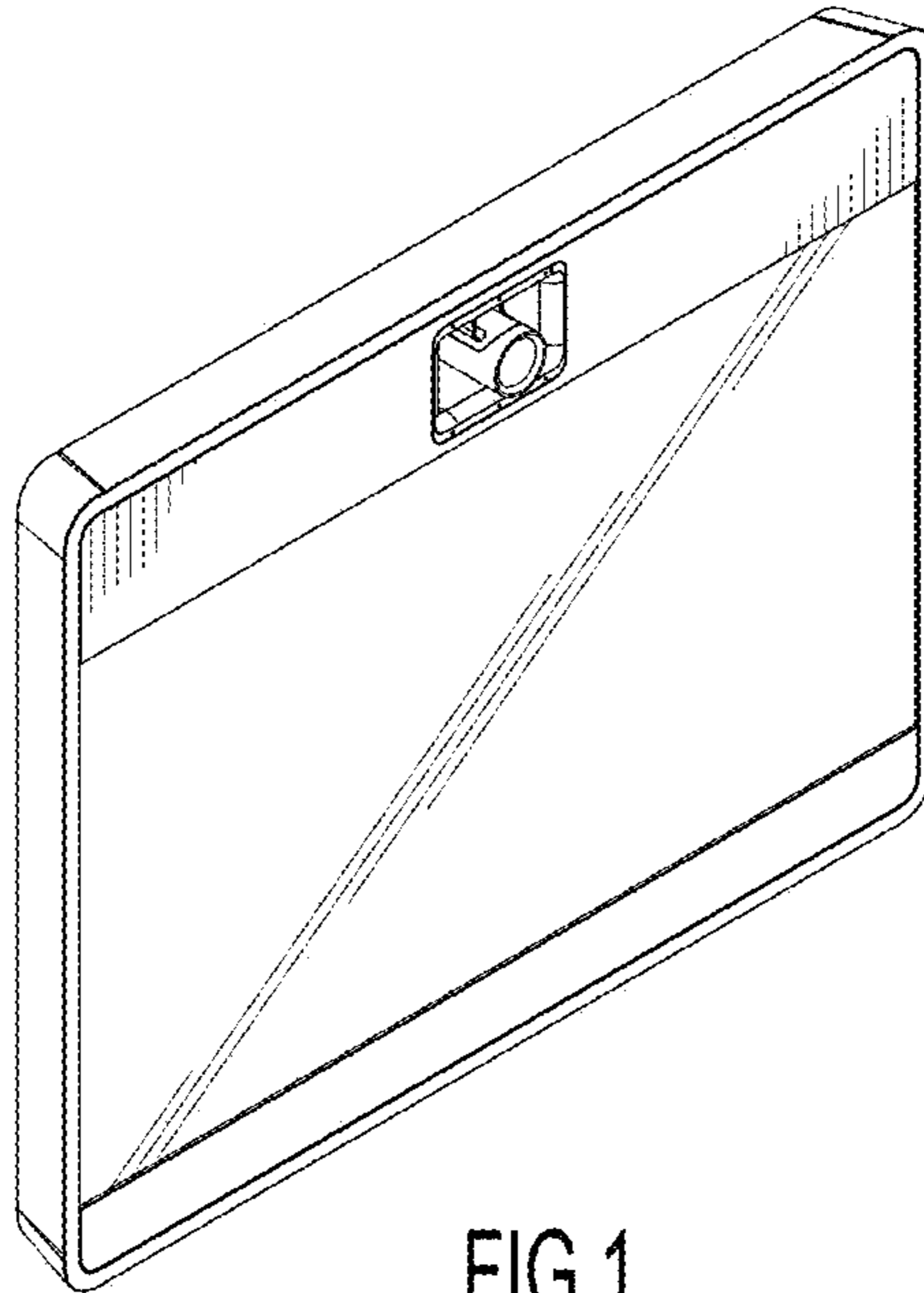

FIG.1

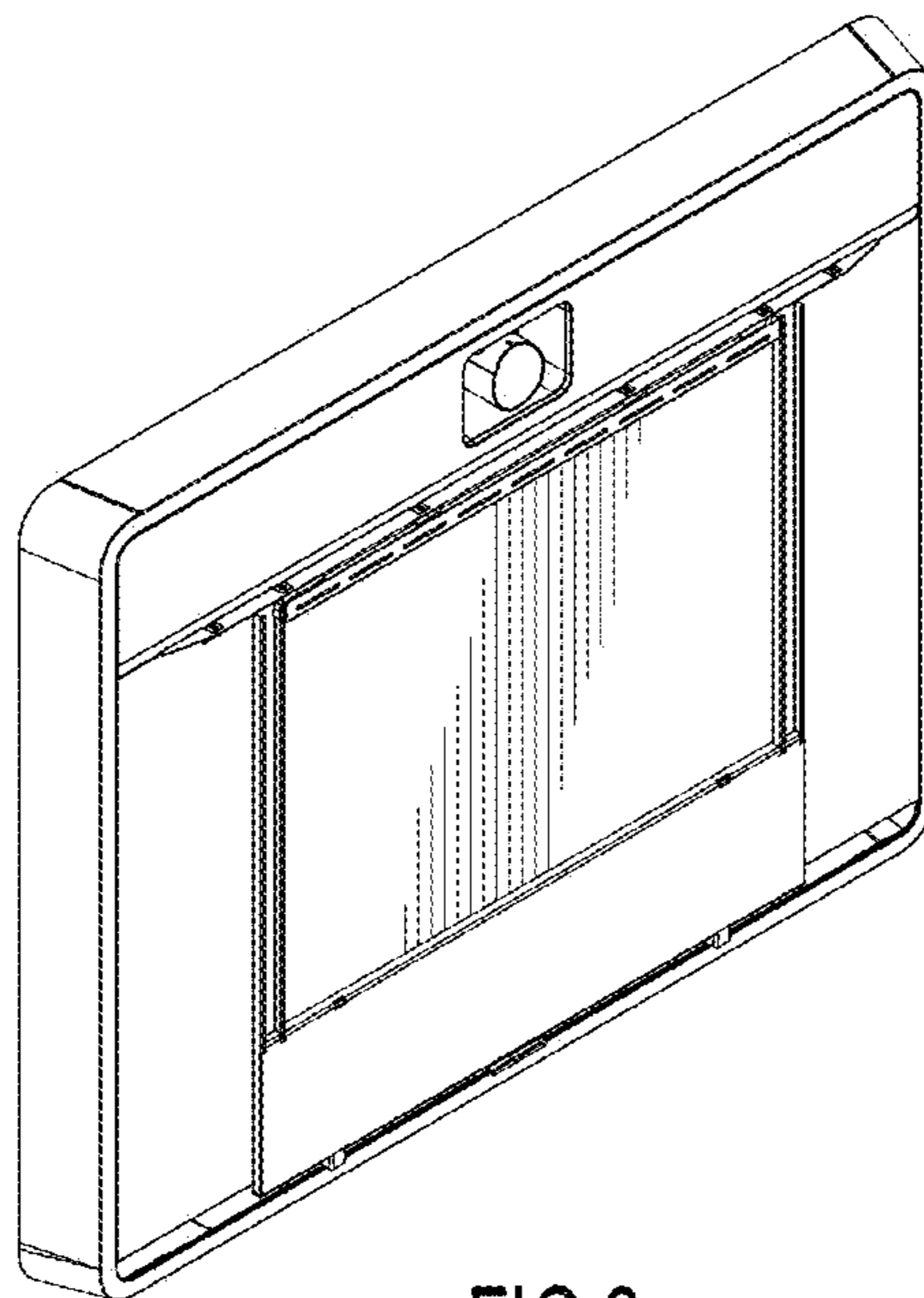

FIG.2

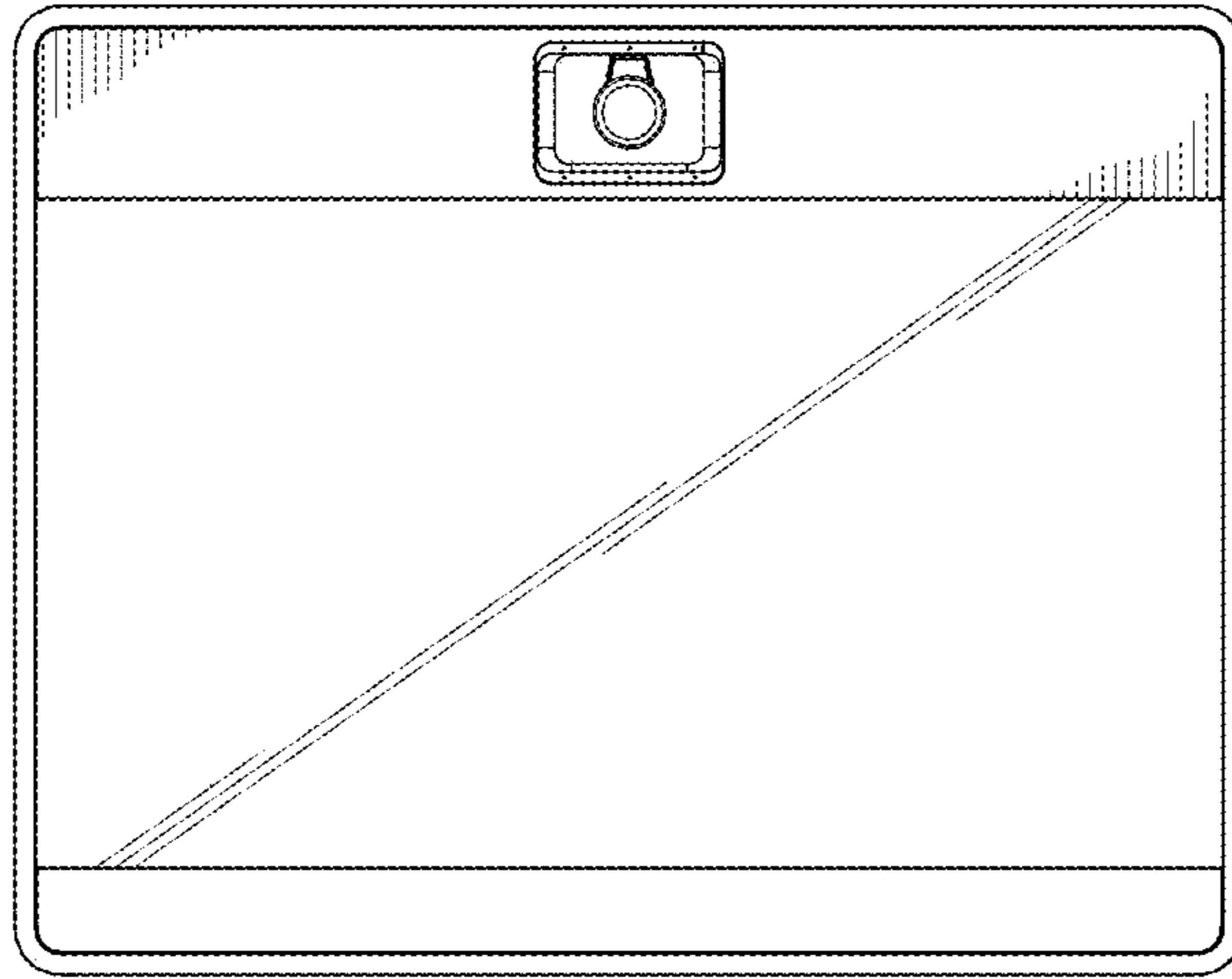

FIG.3

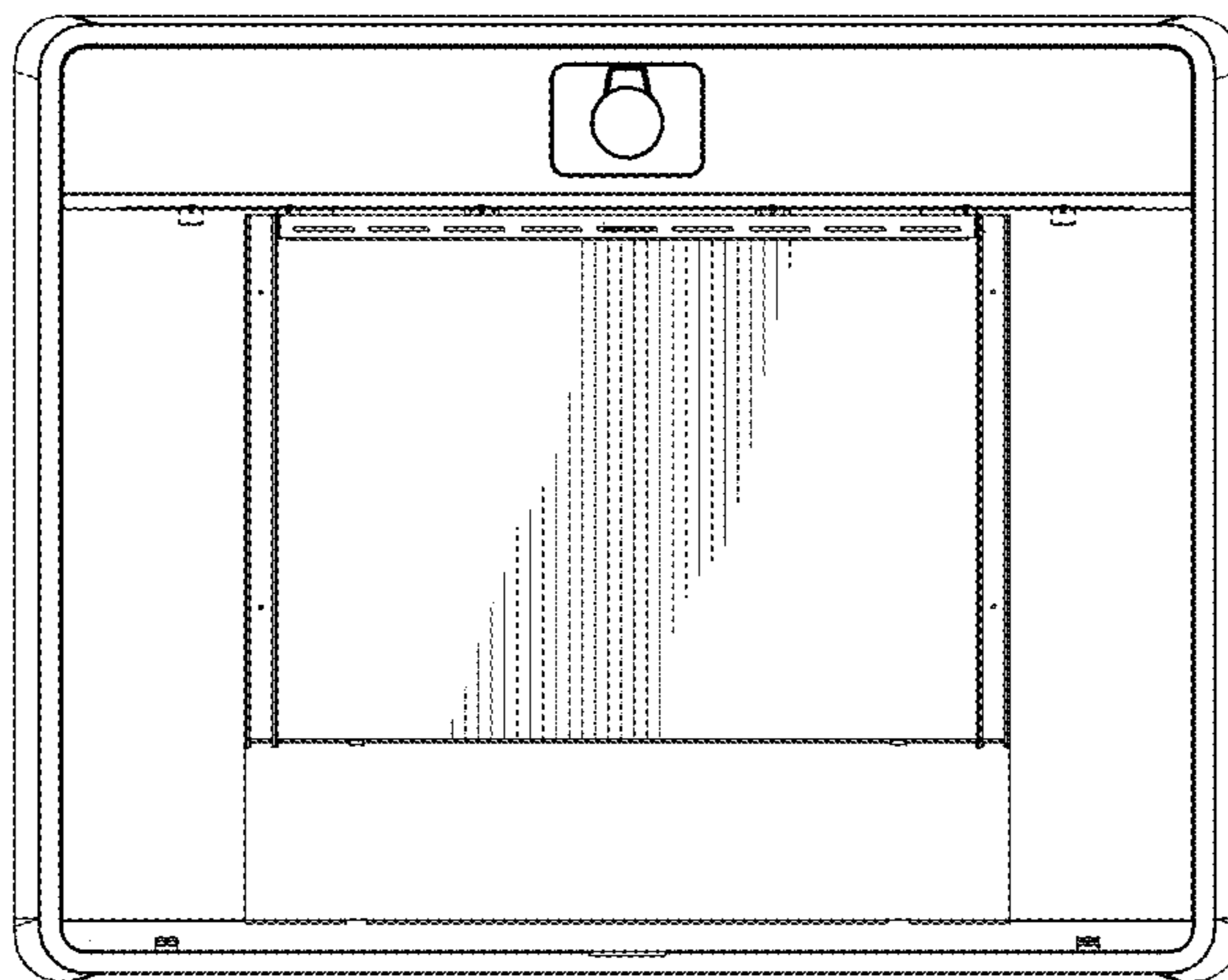

FIG.4

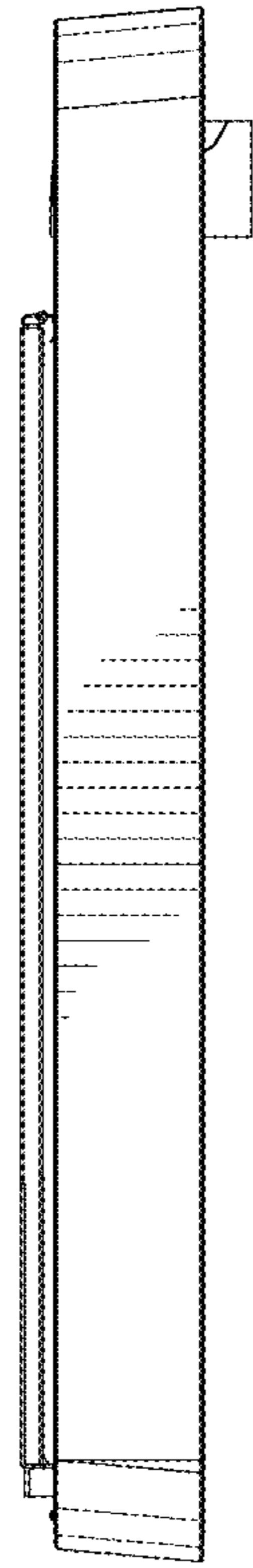

FIG.5

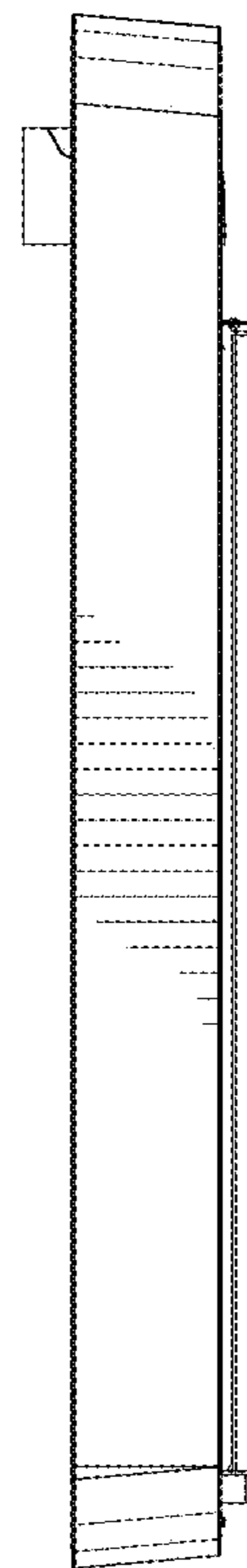

FIG.6

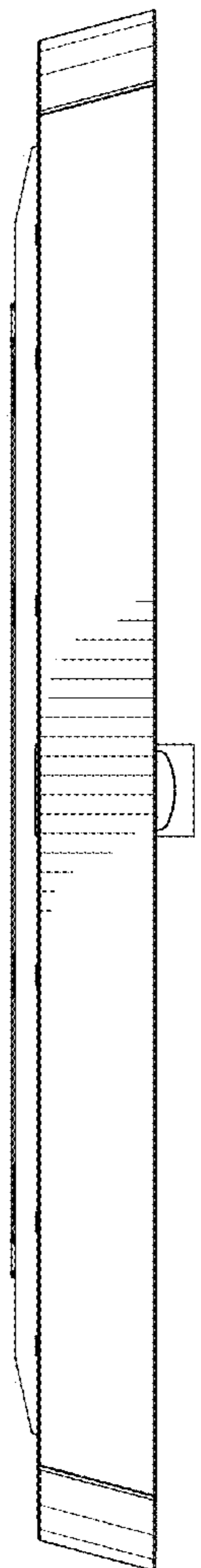

FIG. 7

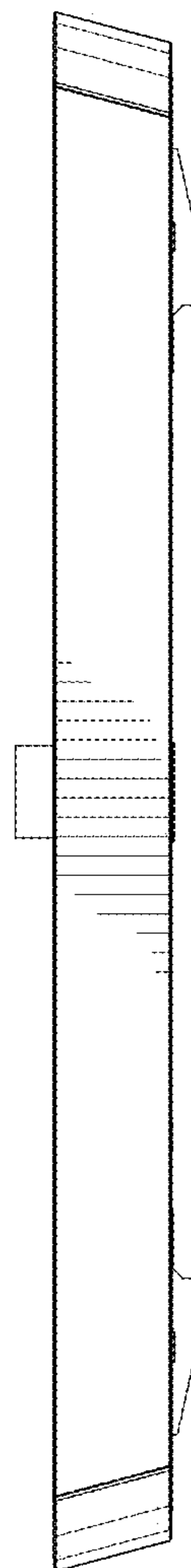

FIG. 8