



US00D756022S

(12) **United States Design Patent**  
**Shipman**

(10) **Patent No.:** **US D756,022 S**

(45) **Date of Patent:** **\*\* \*May 10, 2016**

(54) **COVER FOR WIRE HARNESS CONNECTING VEHICULAR ILLUMINATED INDICIA**

(71) Applicant: **Michael Shipman**, Newport Coast, CA (US)

(72) Inventor: **Michael Shipman**, Newport Coast, CA (US)

(\*) Notice: This patent is subject to a terminal disclaimer.

(\*\*) Term: **14 Years**

(21) Appl. No.: **29/511,029**

(22) Filed: **Dec. 5, 2014**

(51) **LOC (10) Cl.** ..... **26-99**

(52) **U.S. Cl.**  
USPC ..... **D26/113**

(58) **Field of Classification Search**

USPC ..... D10/18, 21, 24, 25, 27, 28, 46, 93, 104, D10/106, 113, 116.1, 121; D26/72, 118, D26/120, 124, 138

CPC ..... A63H 30/04; G05G 2009/04748; H04B 1/1027; F21S 8/04; F21S 2/005; F21S 2/00; B29D 21/04; F21V 15/015; F21V 27/00; F21V 21/14; F21V 21/005; F21Y 2103/00

See application file for complete search history.

(56) **References Cited**

**U.S. PATENT DOCUMENTS**

345,660 A \* 7/1886 Ashworth ..... A41F 9/002  
2/339

D23,114 S \* 3/1894 Ratcliff ..... D7/554.2

(Continued)

**OTHER PUBLICATIONS**

Extruded shape with rounded corners, image post date Dec. 18, 2014, site visited Oct. 8, 2015, (online), <<http://blender.stackexchange.com/questions/21107/can-shapes-with-rounded-corners-be-extruded-with-even-thickness>>.\*

(Continued)

*Primary Examiner* — Kevin Rudzinski

*Assistant Examiner* — Sean D Lough

(74) *Attorney, Agent, or Firm* — Russo & Duckworth, LLP; David G. Duckworth

(57) **CLAIM**

The ornamental design for the cover for wire harness connecting vehicular illuminated indicia, as shown and described.

**DESCRIPTION**

FIG. 1 is a top, left, rear perspective view of the cover for wire harness connecting vehicular illuminated indicia showing my design;

FIG. 2 is a bottom, right, rear perspective view thereof;

FIG. 3 is a front elevation view thereof;

FIG. 4 is a rear elevation view thereof;

FIG. 5 is a left elevation view thereof;

FIG. 6 is a right elevation view thereof;

FIG. 7 is a top plan view thereof;

FIG. 8 is a bottom plan view thereof;

FIG. 9 is a top, left, rear perspective view of the cover for wire harness connecting vehicular illuminated indicia showing my design covering a harness connecting four indicia;

FIG. 10 is a top, left, rear perspective view of the cover for wire harness connecting vehicular illuminated indicia showing my design covering a harness connecting three indicia;

FIG. 11 is a bottom, right, rear perspective view of the cover for wire harness connecting vehicular illuminated indicia showing my design attached to a wire harness connecting three indicia; and,

FIG. 12 is a top plan view of the cover for wire harness connecting vehicular illuminated indicia showing my design is attached to a portion of an emergency response vehicle depicted covering a wire harness connecting four indicia.

The broken lines shown represent environmental subject matter that forms no part of the claimed design. Specifically, the indicia and wire harness illustrated in FIGS. 9-12; and the portion of the emergency response vehicle shown in FIG. 12 illustrate environment of the cover for wire harness connecting vehicular illuminated indicia that forms no part of the claimed design. Further, FIG. 12 includes two-dash dot border lines that limit the environmental subject matter depicted to that of a portion of an emergency response vehicle. The dash-dot border lines as well as portions of the environmental subject matter depicted form no part of the claimed design.

**1 Claim, 7 Drawing Sheets**

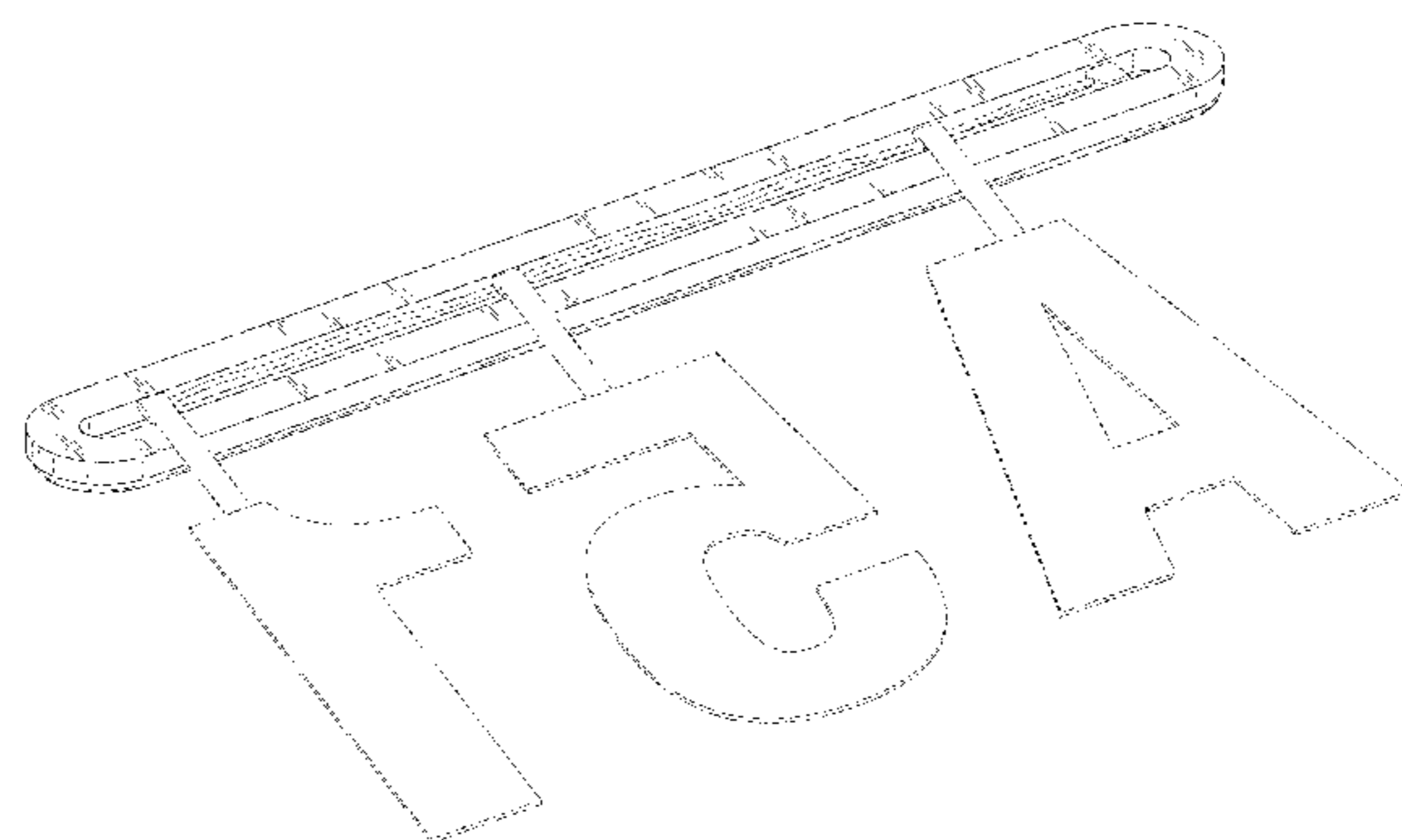
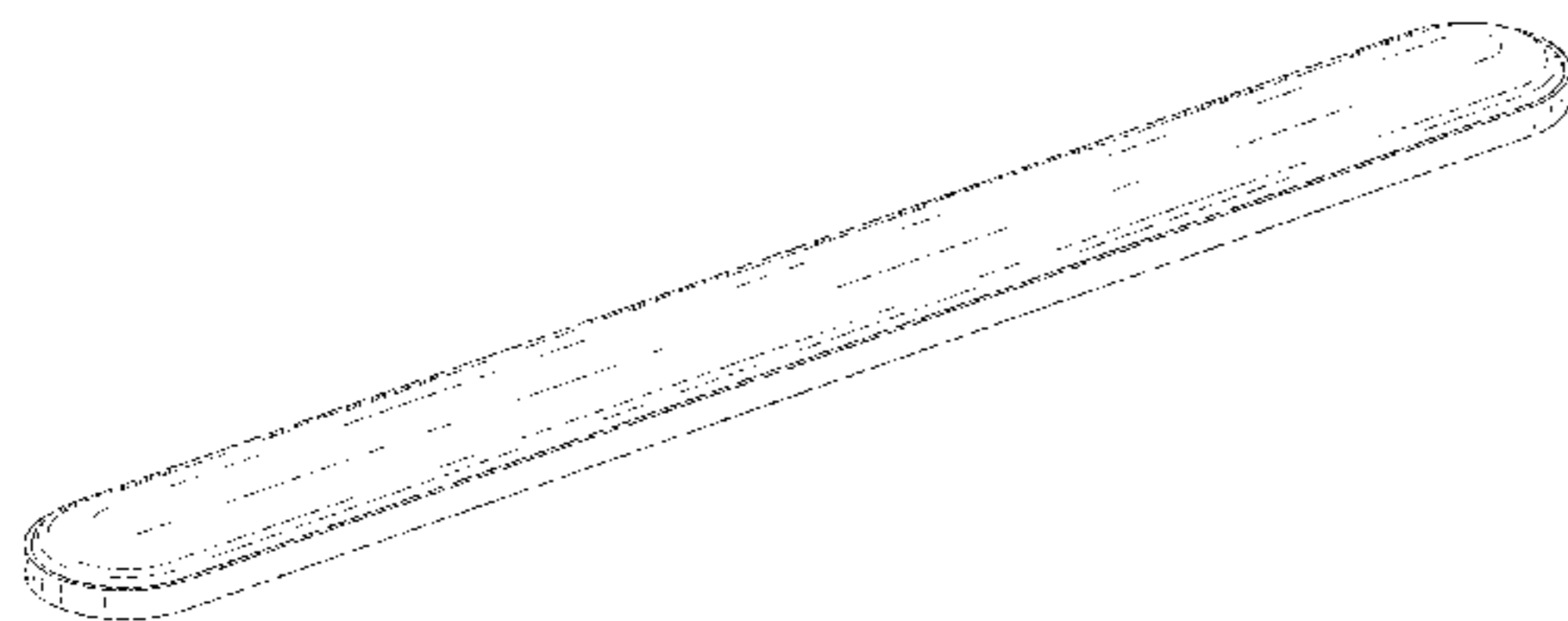

(56)

## References Cited

## U.S. PATENT DOCUMENTS

- 2,634,799 A \* 4/1953 Young ..... A47C 27/081  
267/81
- 2,958,810 A \* 11/1960 Balf ..... G01R 11/04  
200/51.1
- D203,160 S \* 12/1965 Blum et al. .... D25/121
- 3,436,719 A \* 4/1969 Scheinbaum ..... H01M 2/22  
439/504
- D279,067 S \* 6/1985 Kuster ..... D7/554.2
- 4,692,198 A \* 9/1987 Borresen ..... B41M 5/035  
156/235
- D292,322 S \* 10/1987 Krol ..... D26/72
- 4,700,981 A \* 10/1987 Seyler ..... B21D 39/20  
156/295
- D298,360 S \* 11/1988 Dacanay ..... D26/85
- D309,593 S \* 7/1990 Bailey ..... D12/167
- D322,013 S \* 12/1991 Daenen ..... D7/502
- 5,125,606 A \* 6/1992 Cassano ..... A47B 21/0371  
248/118
- 5,154,715 A \* 10/1992 Van Iten ..... A61F 13/5616  
604/385.03
- D333,363 S \* 2/1993 Lee ..... D26/142
- 5,200,280 A \* 4/1993 Karasa ..... H01M 2/105  
429/100
- 5,224,013 A \* 6/1993 Pagliuca ..... H01T 4/06  
337/32
- D341,509 S \* 11/1993 Evans ..... D6/601
- 5,381,320 A \* 1/1995 Jordan ..... F21V 3/00  
362/147
- D359,374 S \* 6/1995 Weinstock ..... D26/80
- 5,445,858 A \* 8/1995 Nwoko ..... A45F 3/12  
428/174
- D362,315 S \* 9/1995 Herst ..... D26/76
- D366,038 S \* 1/1996 Rogers ..... D14/461
- D374,737 S \* 10/1996 Can ..... D26/80
- 5,579,657 A \* 12/1996 Makous ..... E05B 73/0005  
248/51
- D380,854 S \* 7/1997 Bray ..... D26/142
- D381,450 S \* 7/1997 Sonneman ..... D26/72
- D386,007 S \* 11/1997 Eckhardt ..... D11/131
- D396,323 S \* 7/1998 Miranda ..... D26/142
- D399,195 S \* 10/1998 Cummings ..... D14/460
- D414,580 S \* 9/1999 Herst ..... D26/76
- 6,219,867 B1 \* 4/2001 Yates ..... A47B 21/0371  
248/118
- 6,247,828 B1 \* 6/2001 Herst ..... F21S 8/06  
362/217.03
- D444,910 S \* 7/2001 Lee ..... D26/142
- 6,292,964 B1 \* 9/2001 Rose ..... A47G 9/10  
5/630
- 6,434,087 B1 \* 8/2002 Schell ..... G11B 11/10506  
369/116
- 6,499,703 B2 \* 12/2002 Chou ..... A47B 21/0371  
248/118
- D476,517 S \* 7/2003 Davis ..... D6/601
- D477,767 S \* 7/2003 Burdett ..... D8/330
- 6,694,553 B1 \* 2/2004 Yates ..... A47B 21/0371  
5/646
- D493,565 S \* 7/2004 Smith ..... D26/118
- D498,018 S \* 11/2004 Sieczkowski ..... D26/118
- D498,965 S \* 11/2004 Thompson ..... D6/601
- D526,736 S \* 8/2006 Blackman ..... D26/76
- 7,157,633 B1 \* 1/2007 Kopesec ..... G09B 15/06  
248/118
- D543,125 S \* 5/2007 Feibelman ..... D10/106.9
- D545,477 S \* 6/2007 DeBruyne ..... D26/76
- D548,373 S \* 8/2007 Handsaker ..... D26/24
- D549,871 S \* 8/2007 Karussi ..... D28/8.1
- D551,041 S \* 9/2007 Park ..... D8/19
- D551,792 S \* 9/2007 Philpot ..... D26/76
- D562,570 S \* 2/2008 Leyden ..... D6/309
- D567,425 S \* 4/2008 Yates ..... D26/76
- D574,550 S \* 8/2008 Salman ..... D26/113
- D589,966 S \* 4/2009 Zuckerman ..... D14/461
- D593,703 S \* 6/2009 Copeland ..... D26/89
- D611,645 S \* 3/2010 Copeland ..... D26/76
- D615,469 S \* 5/2010 Huang ..... D12/190
- D617,513 S \* 6/2010 Still ..... D32/29.1
- D619,669 S \* 7/2010 Mesirov ..... D21/797
- D626,267 S \* 10/2010 Ng ..... D26/76
- D639,465 S \* 6/2011 Abernethy ..... D26/24
- D642,726 S \* 8/2011 Khubani ..... D26/37
- D644,647 S \* 9/2011 Sykes ..... D14/447
- D647,241 S \* 10/2011 Takahashi ..... D26/72
- D649,673 S \* 11/2011 Liang ..... D26/72
- D650,507 S \* 12/2011 Osiecki ..... D26/72
- D658,798 S \* 5/2012 Hillard ..... D26/51
- D665,195 S \* 8/2012 Hsieh ..... D8/71
- D668,383 S \* 10/2012 Schieffelin ..... D26/142
- D670,524 S \* 11/2012 Oberlander ..... D6/601
- D677,422 S \* 3/2013 Lin ..... D26/120
- D681,866 S \* 5/2013 Lin ..... D26/120
- D685,943 S \* 7/2013 Duquette ..... D26/74
- D686,772 S \* 7/2013 Waltz ..... D26/118
- D687,177 S \* 7/2013 Grandsart ..... D26/85
- D690,847 S \* 10/2013 Wang ..... D26/24
- D693,813 S \* 11/2013 Symons ..... D14/432
- D695,445 S \* 12/2013 Panchisin ..... D26/118
- D703,398 S \* 4/2014 Nixon ..... D32/29.1
- D703,399 S \* 4/2014 Nixon ..... D32/29.1
- D706,516 S \* 6/2014 Caglia ..... D1/105
- D707,880 S \* 6/2014 Magnusson ..... D26/120
- D709,242 S \* 7/2014 Rogers ..... D26/142
- D710,049 S \* 7/2014 Haws ..... D26/142
- D712,086 S \* 8/2014 Barbato ..... D26/122
- D712,089 S \* 8/2014 Rogers ..... D26/142
- D725,816 S \* 3/2015 Fissell ..... D26/113
- 8,966,795 B1 \* 3/2015 Shipman ..... B60Q 1/503  
40/592
- D727,588 S \* 4/2015 Kemper, Sr. .... D99/1
- D731,700 S \* 6/2015 Santoro ..... D26/118
- D735,390 S \* 7/2015 Yanping ..... D26/74
- D735,392 S \* 7/2015 Ng ..... D26/76
- D737,500 S \* 8/2015 Santoro ..... D26/120
- 2004/0167056 A1 \* 8/2004 Lentsch ..... C11D 1/521  
510/504
- 2010/0295748 A1 \* 11/2010 Bradley ..... H01Q 1/42  
343/872
- 2014/0059904 A1 \* 3/2014 Shipman ..... G09F 13/20  
40/542
- 2015/0047238 A1 \* 2/2015 Shipman ..... B60Q 1/2611  
40/544
- 2015/0130722 A1 \* 5/2015 Shipman ..... G06F 3/0202  
345/170

## OTHER PUBLICATIONS

Carved Wooden Oval Bowl, image post date 2000, site visited Oct. 8, 2015, (online), <<https://www.pier1.com/Carved-Wooden-Oval-Bowl/2916572,default,pd.html?cgid=vases>>.\*

Pickup surrounds, image post date 1998, site visited Oct. 8, 2015, (online), <<https://fryerguitars.wordpress.com/red-special-restoration-1998/>>.\*

\* cited by examiner

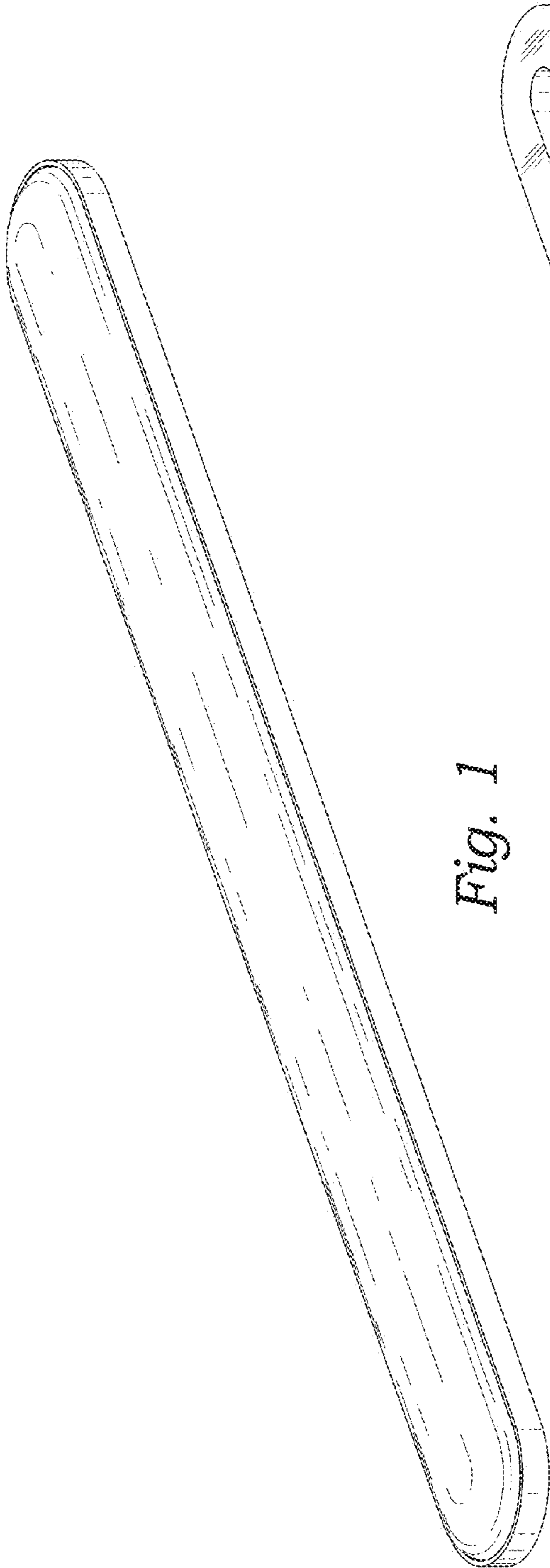

Fig. 1

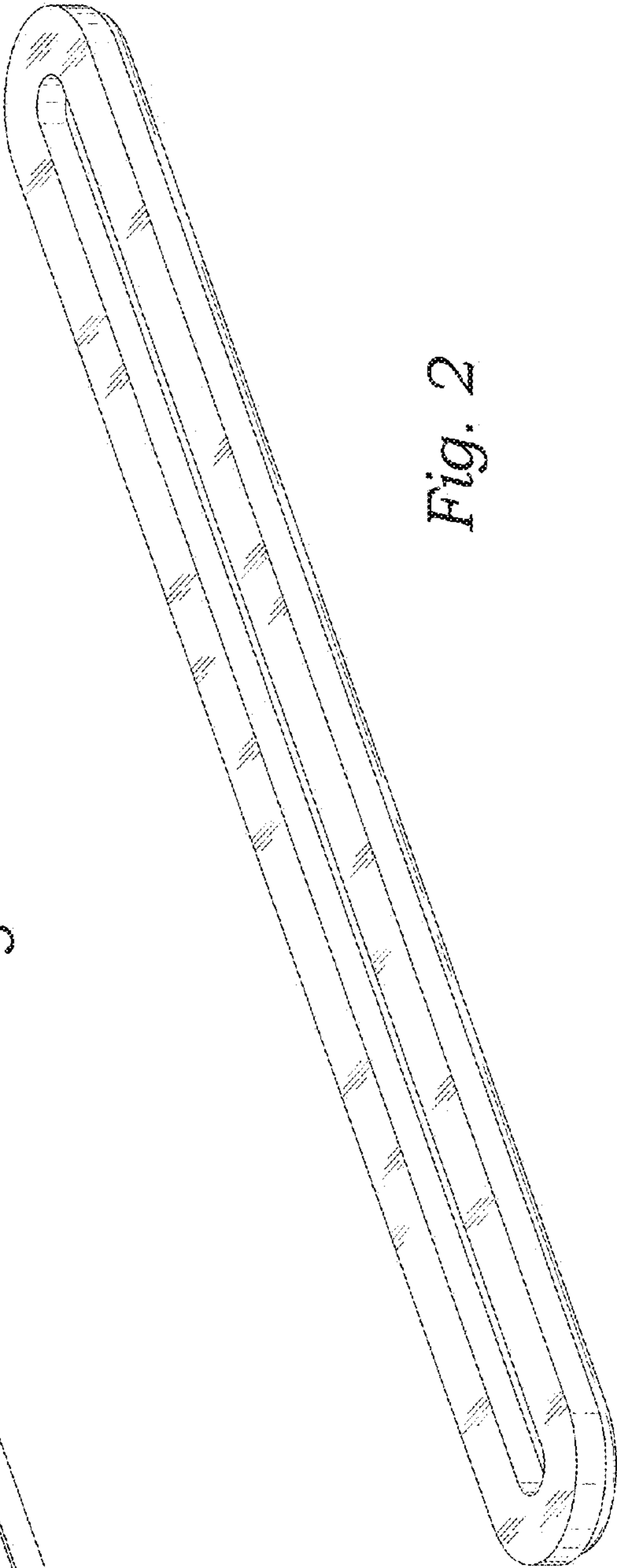

Fig. 2

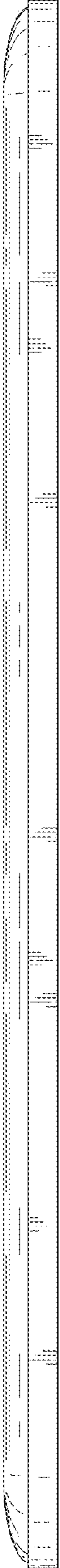

Fig. 3

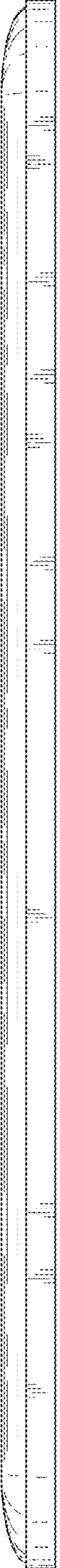

Fig. 4

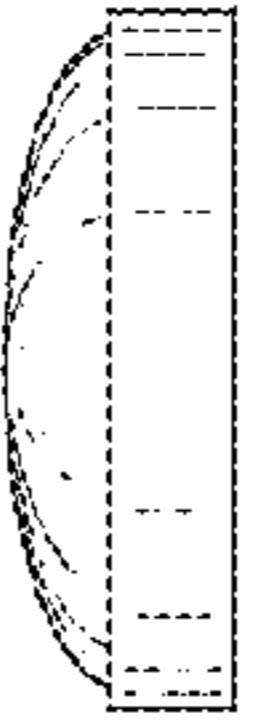
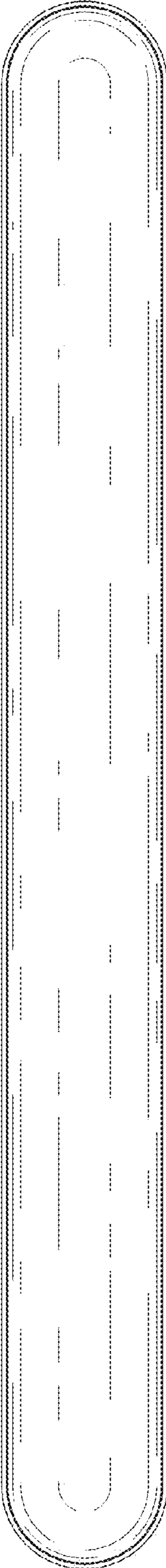

Fig. 5



Fig. 6



*Fig. 7*

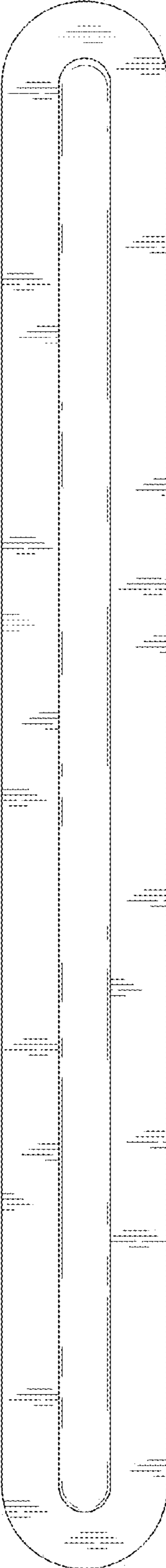

*Fig. 8*

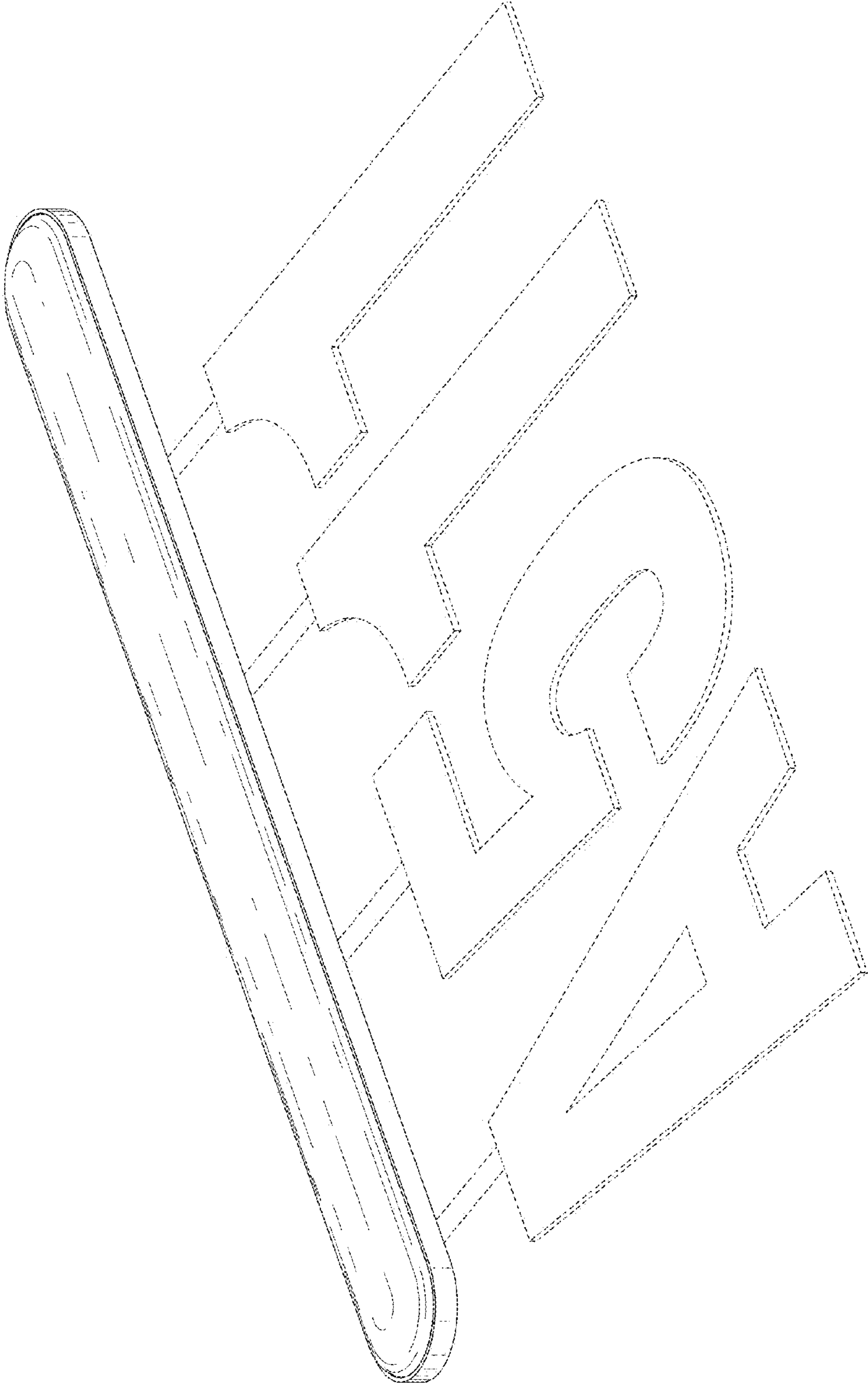

Fig. 9

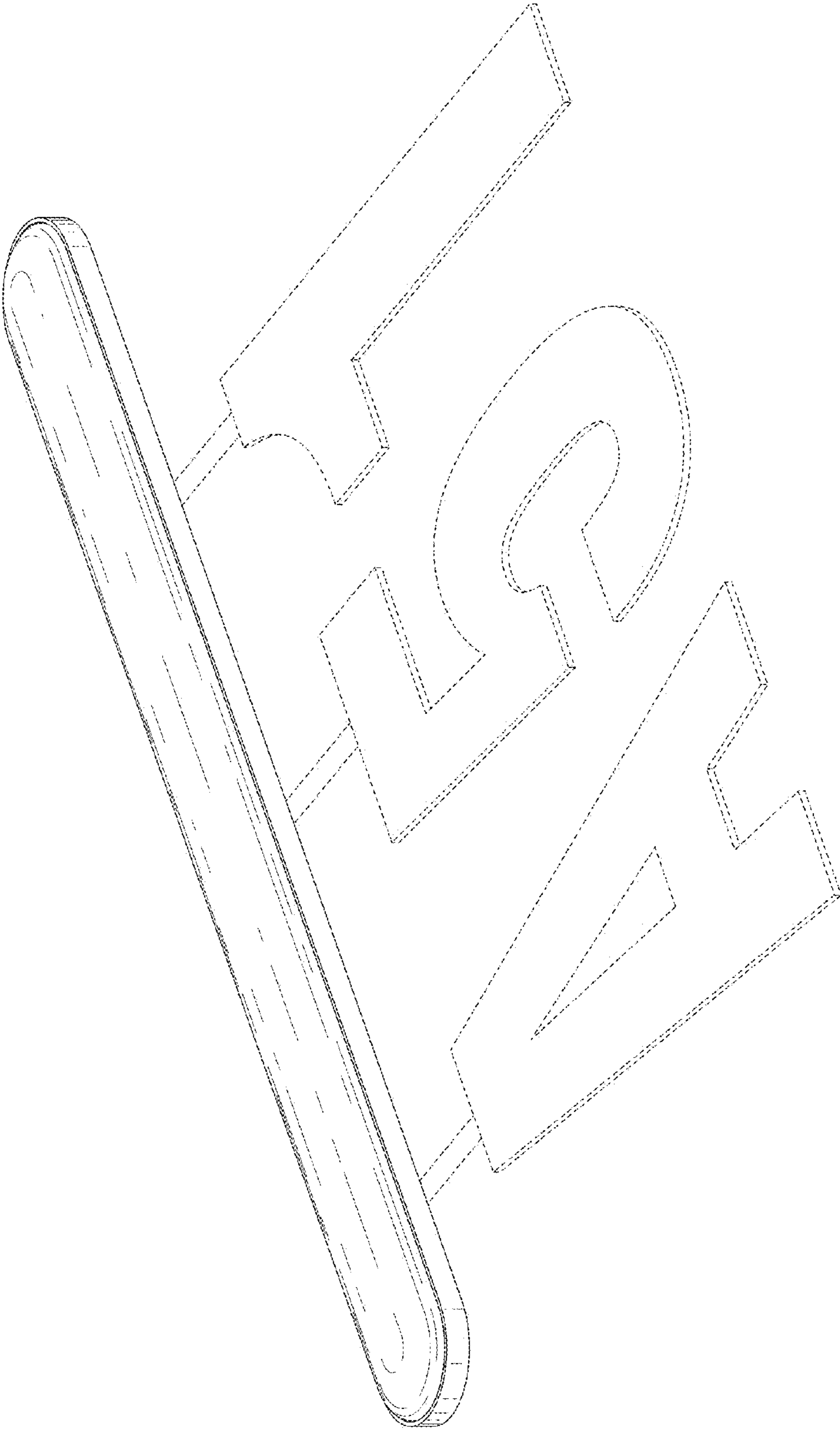
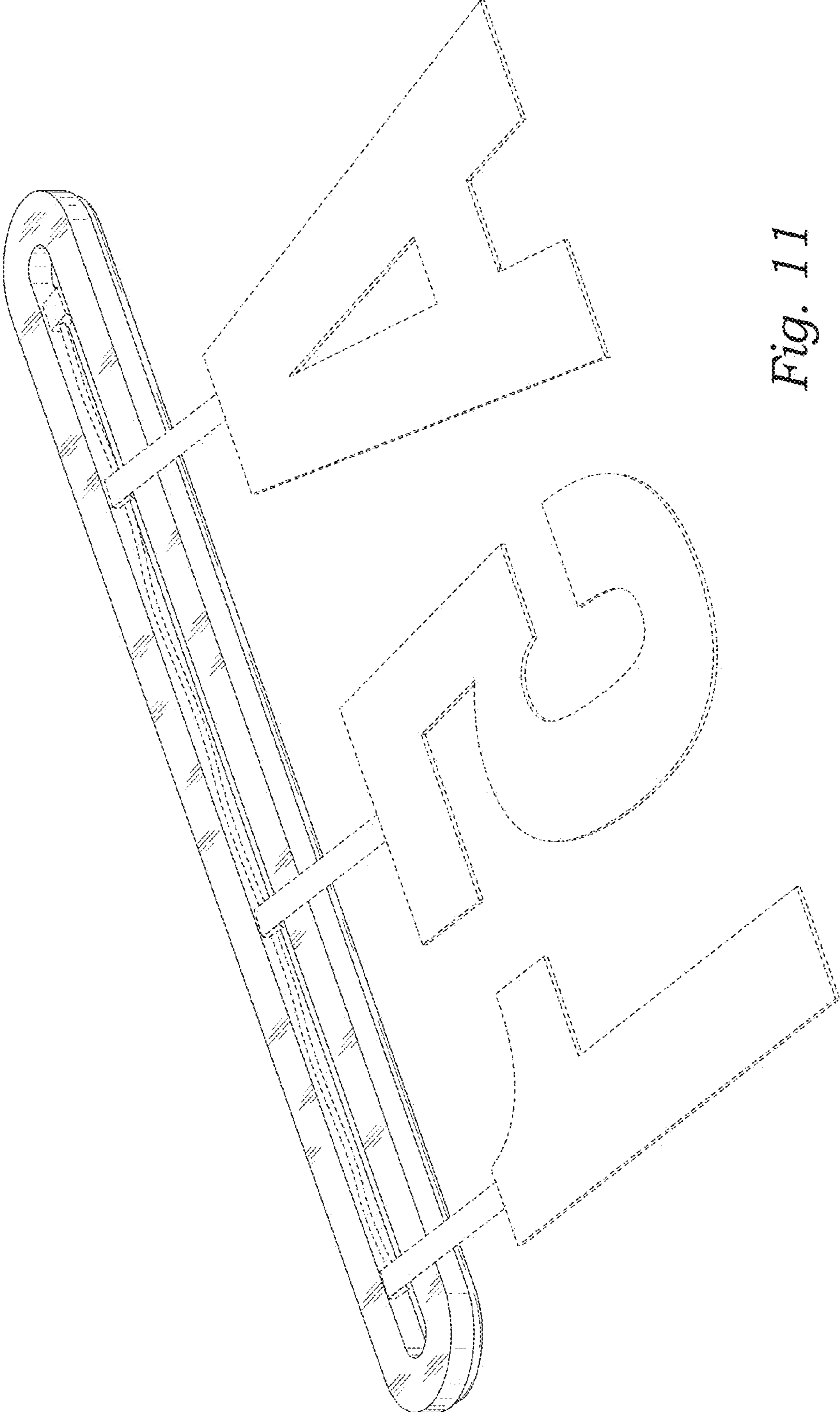
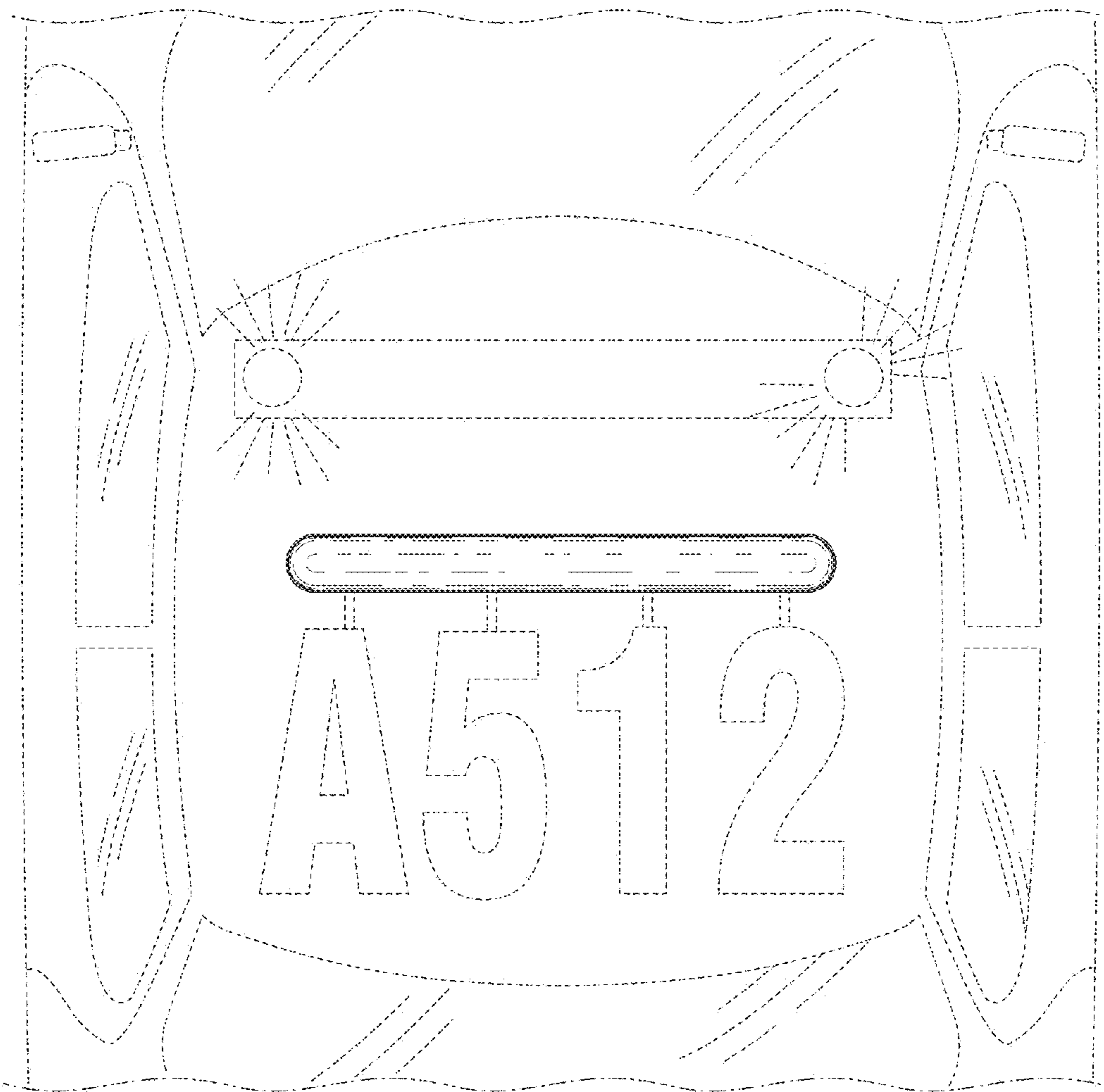

Fig. 10



*Fig. 11*





*Fig. 12*