



US00D755923S

(12) **United States Design Patent**
Kosaka et al.

(10) **Patent No.:** **US D755,923 S**
(45) **Date of Patent:** **** May 10, 2016**

- (54) **NOZZLE**
- (71) Applicant: **Anest Iwata Corporation**, Yokohama, Kanagawa-ken (JP)
- (72) Inventors: **Shozo Kosaka**, Oamishirasato (JP); **Nobuhiro Sawata**, Daisen (JP)
- (73) Assignee: **Anest Iwata Corporation**, Yokohama (JP)
- (**) Term: **14 Years**
- (21) Appl. No.: **29/519,342**
- (22) Filed: **Mar. 4, 2015**
- (30) **Foreign Application Priority Data**
 - Sep. 30, 2014 (JP) 2014-021686
 - Sep. 30, 2014 (JP) 2014-021687
 - Sep. 30, 2014 (JP) 2014-021688
- (51) **LOC (10) Cl.** **23-01**
- (52) **U.S. Cl.**
USPC **D23/213**
- (58) **Field of Classification Search**
USPC D23/213, 226; 222/566; 239/600, 601, 239/597
CPC B05B 1/00; B05B 15/065
See application file for complete search history.

- (56) **References Cited**
U.S. PATENT DOCUMENTS
 - 591,067 A * 10/1897 Wallace B05B 1/00 137/142
 - 2,755,137 A * 7/1956 Hughf B05B 1/00 239/288.5
 - 4,346,849 A * 8/1982 Rood B05B 1/00 239/597
 - 5,727,739 A * 3/1998 Hamilton F16L 37/244 239/600
 - 6,079,638 A * 6/2000 Chang A62C 31/02 239/390
 - 6,557,787 B2 * 5/2003 Swan B05B 1/267 239/597

- 6,712,293 B2 * 3/2004 Swan B05B 1/046 239/419.5
- 7,032,832 B2 * 4/2006 Kassanits B05B 15/065 239/597
- 7,163,163 B2 * 1/2007 Waddelow B05B 1/042 239/590
- D569,477 S * 5/2008 Fulkerson D23/213
- 7,708,211 B2 * 5/2010 Maier B05C 17/00516 222/502
- 7,806,350 B2 * 10/2010 Langiewicz B05B 1/04 239/505
- D712,009 S * 8/2014 Gopalan D23/213
- RE45,395 E * 3/2015 Fulkerson D23/213
- D723,658 S * 3/2015 Meister D23/213

* cited by examiner

Primary Examiner — Robin V Webster
(74) *Attorney, Agent, or Firm* — Flaster/Greenberg P.C.

(57) **CLAIM**
The ornamental design of a nozzle, as shown and described.

DESCRIPTION

FIG. 1 is a top front perspective view of an example of a nozzle of the new design.

FIG. 2 is an enlarged top front perspective view of the nozzle example of FIG. 1.

FIG. 3 is a first side view of the nozzle example of FIG. 1, wherein the top side view, the opposite side view, and the bottom side view are the essentially the same and each visible upon sequential rotations of the nozzle by 90 degrees.

FIG. 4 is a first cross section view of the nozzle example of FIG. 1.

FIG. 5 is an alternate side view of the nozzle example of FIG. 1, upon rotation of the nozzle by 45 degrees from the position of the first side elevation.

FIG. 6 is a second cross section view of the nozzle example of FIG. 1.

FIG. 7 is a front elevation view of the nozzle example of FIG. 1.

FIG. 8 is a top front perspective view of a further example of a nozzle of the new design.

FIG. 9 is an enlarged top front perspective view of the nozzle example of FIG. 8.

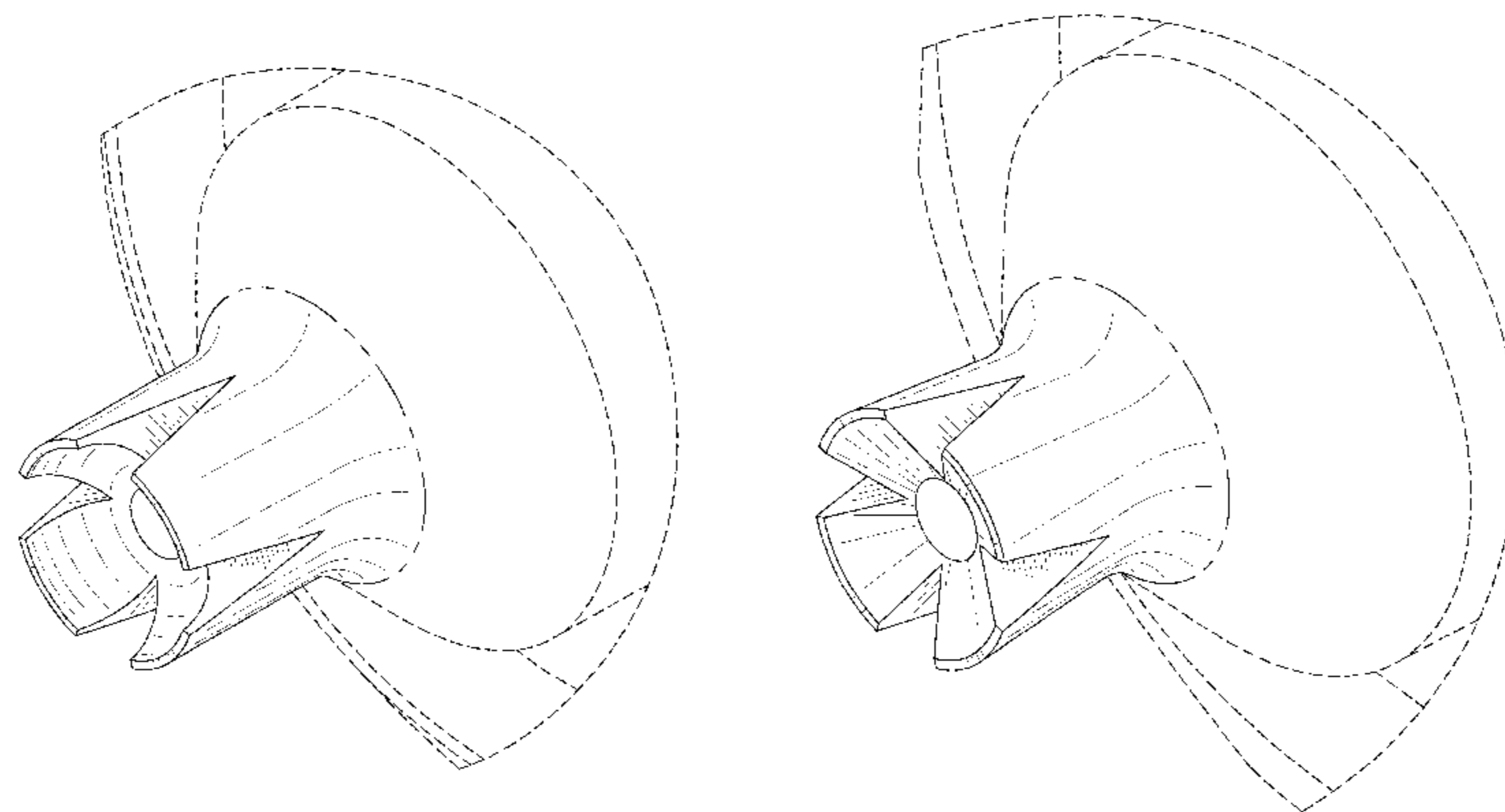

FIG. **10** is a first side view of the nozzle example of FIG. **8**, wherein the top side view, the opposite side view, and the bottom side view are the essentially the same, with each being visible upon sequential rotations of the nozzle by 90 degrees, FIG. **11** is a first cross section view of the nozzle example of FIG. **8**.

FIG. **12** is an alternate side view of the nozzle example of FIG. **8**, upon rotation of the nozzle by 45 degrees from the position of the first side elevation.

FIG. **13** is a second cross section view of the nozzle example of FIG. **8**,

FIG. **14** is a front elevation view of the nozzle example of FIG. **8**.

FIG. **15** is a top front perspective view of a further example of a nozzle of the new design.

FIG. **16** is an enlarged top front perspective view of the nozzle example of FIG. **15**.

FIG. **17** is a first side view of the nozzle example of FIG. **15**, wherein the top side view, the opposite side view, and the bottom side view are the essentially the same, with each being visible upon sequential rotations of the nozzle by 90 degrees. FIG. **18** is a first cross section view of the nozzle example of FIG. **15**.

FIG. **19** is an alternate side view of the nozzle example of FIG. **15**, upon rotation of the nozzle by 45 degrees from the position of the first side elevation.

FIG. **20** is a second cross section view of the nozzle example of FIG. **15**; and,

FIG. **21** is a front elevation view of the nozzle example of FIG. **15**.

In the drawings, broken lines are provided for the purpose of presenting a typical environment of the design. The broken lines form no part of the claimed design.

1 Claim, 21 Drawing Sheets

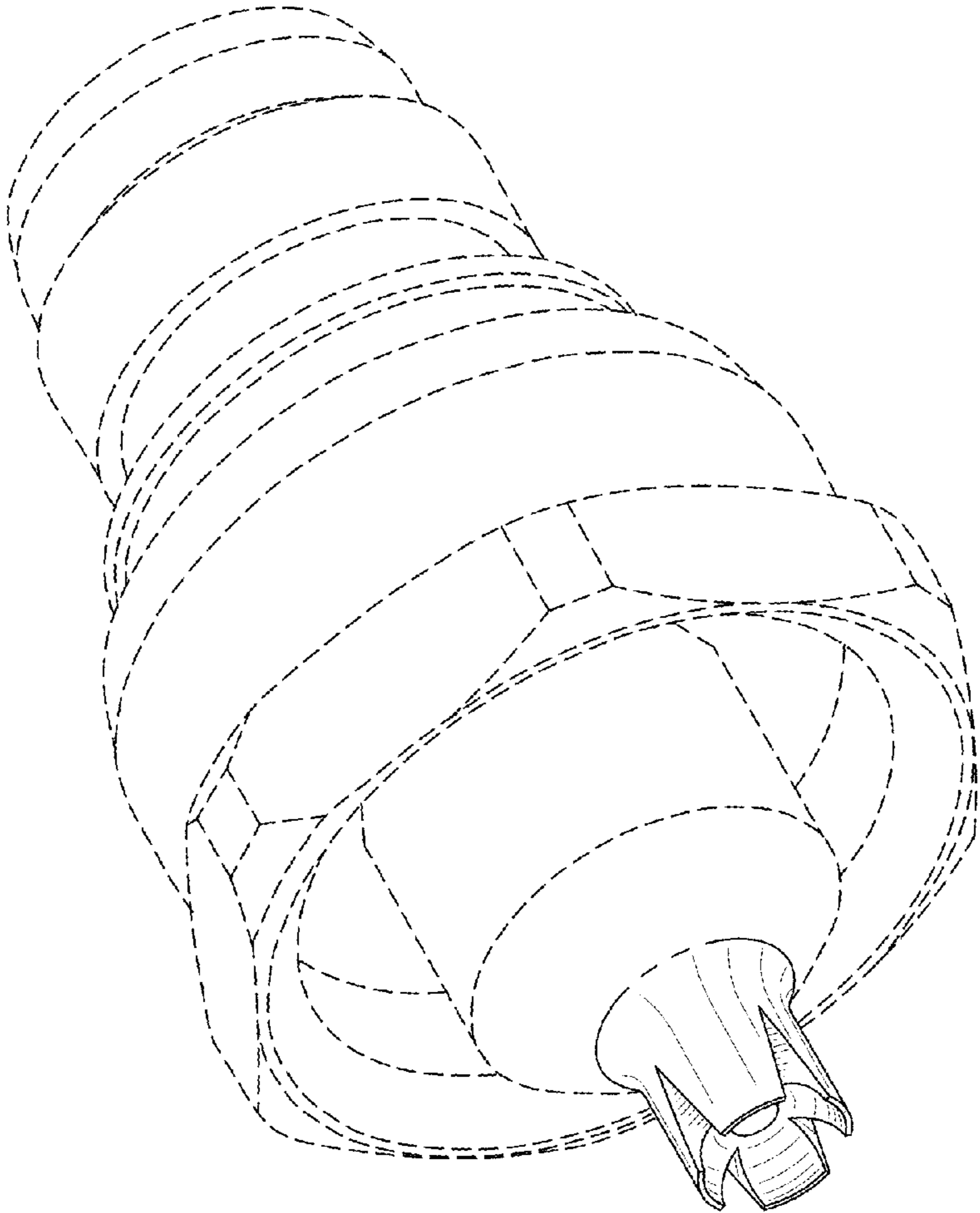

FIG. 1

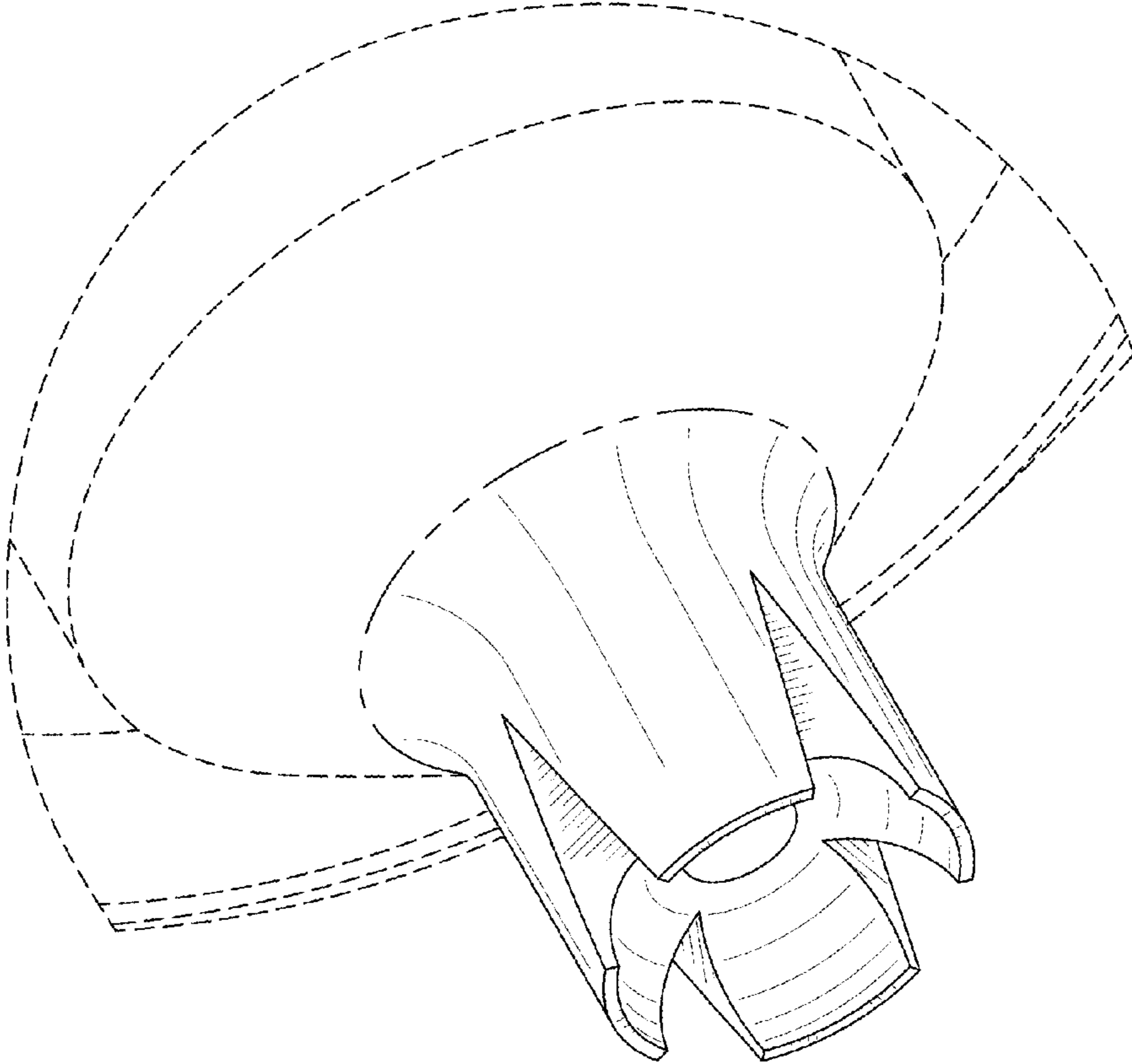

FIG. 2

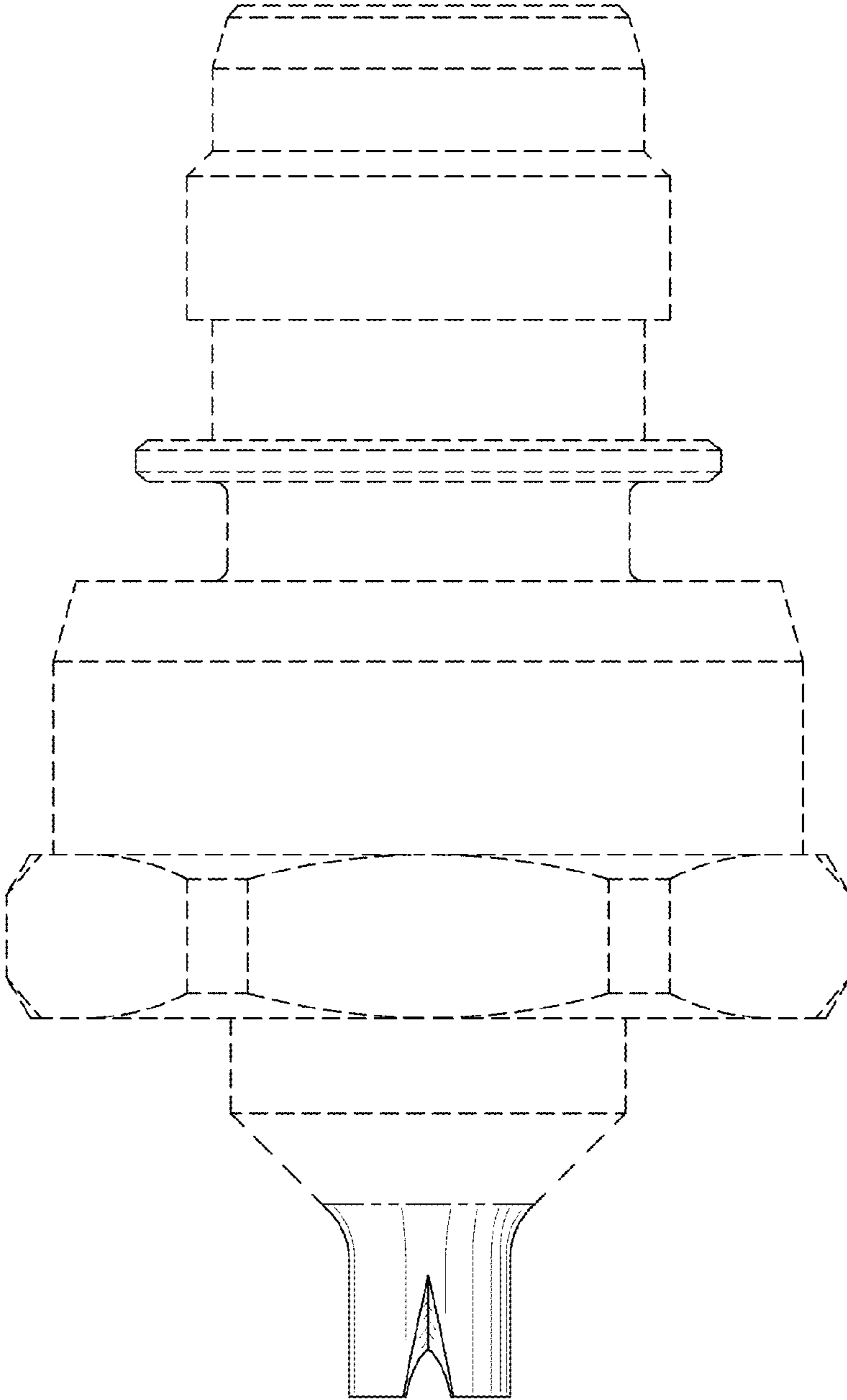

FIG. 3

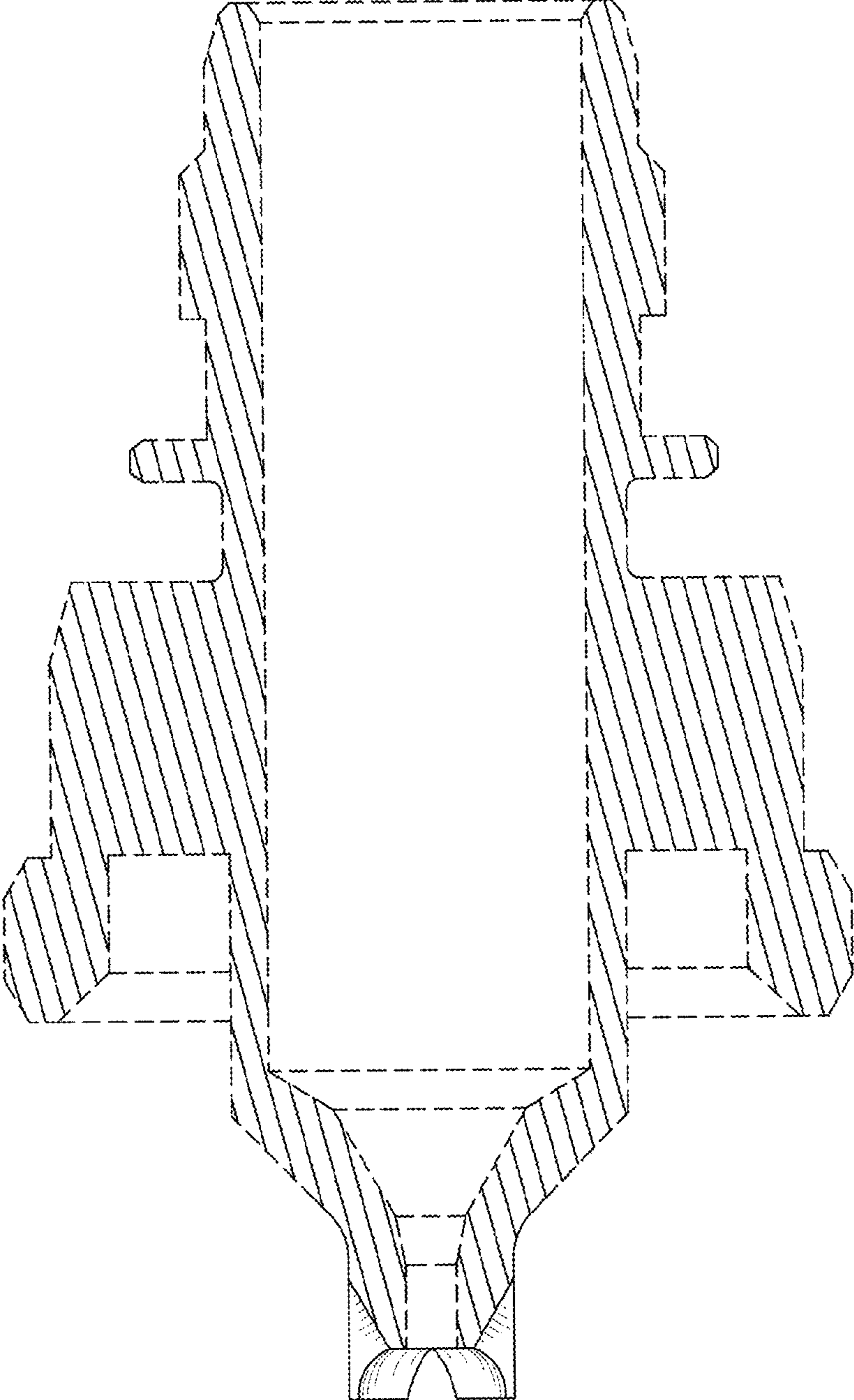

FIG. 4

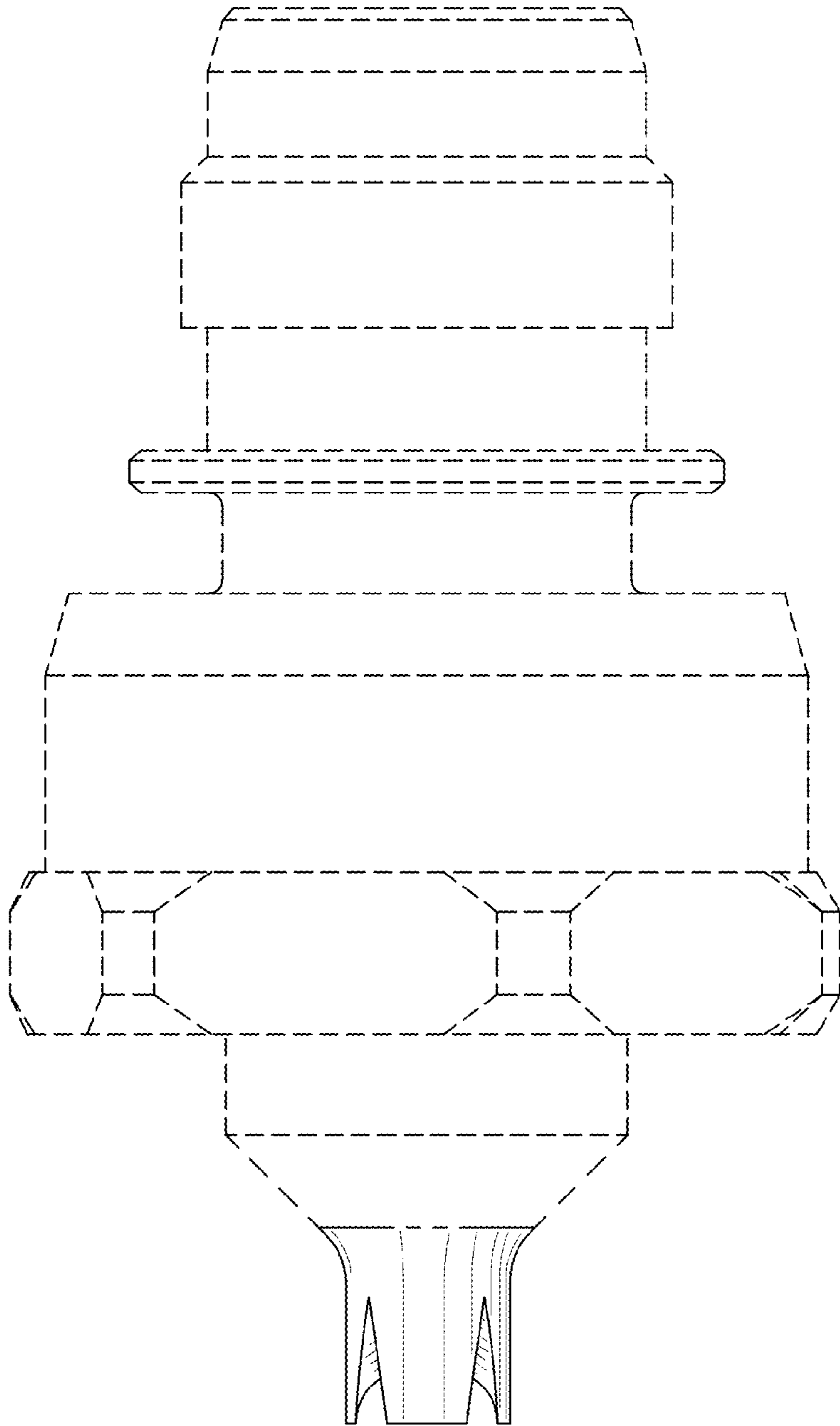

FIG. 5

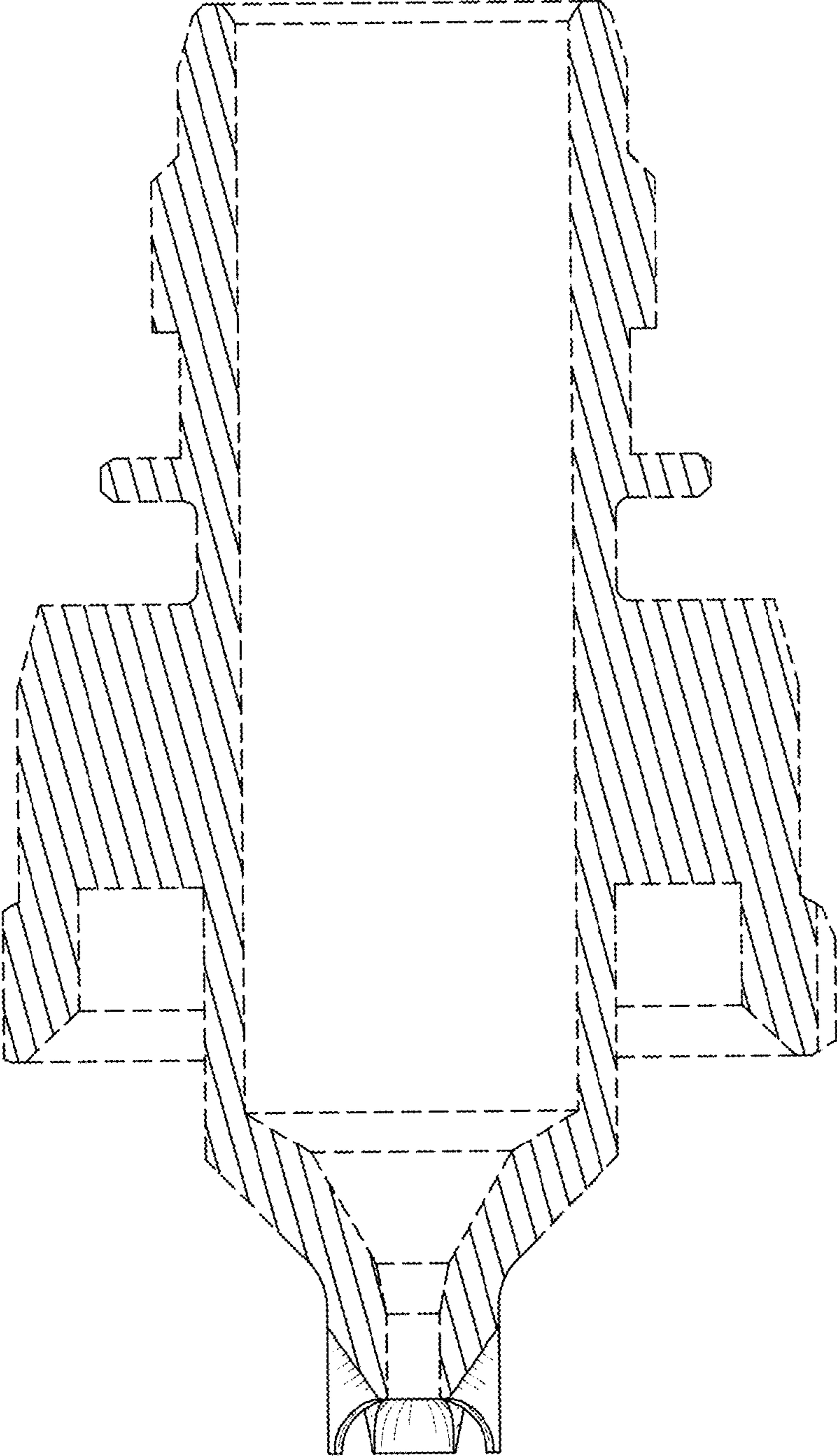

FIG. 6

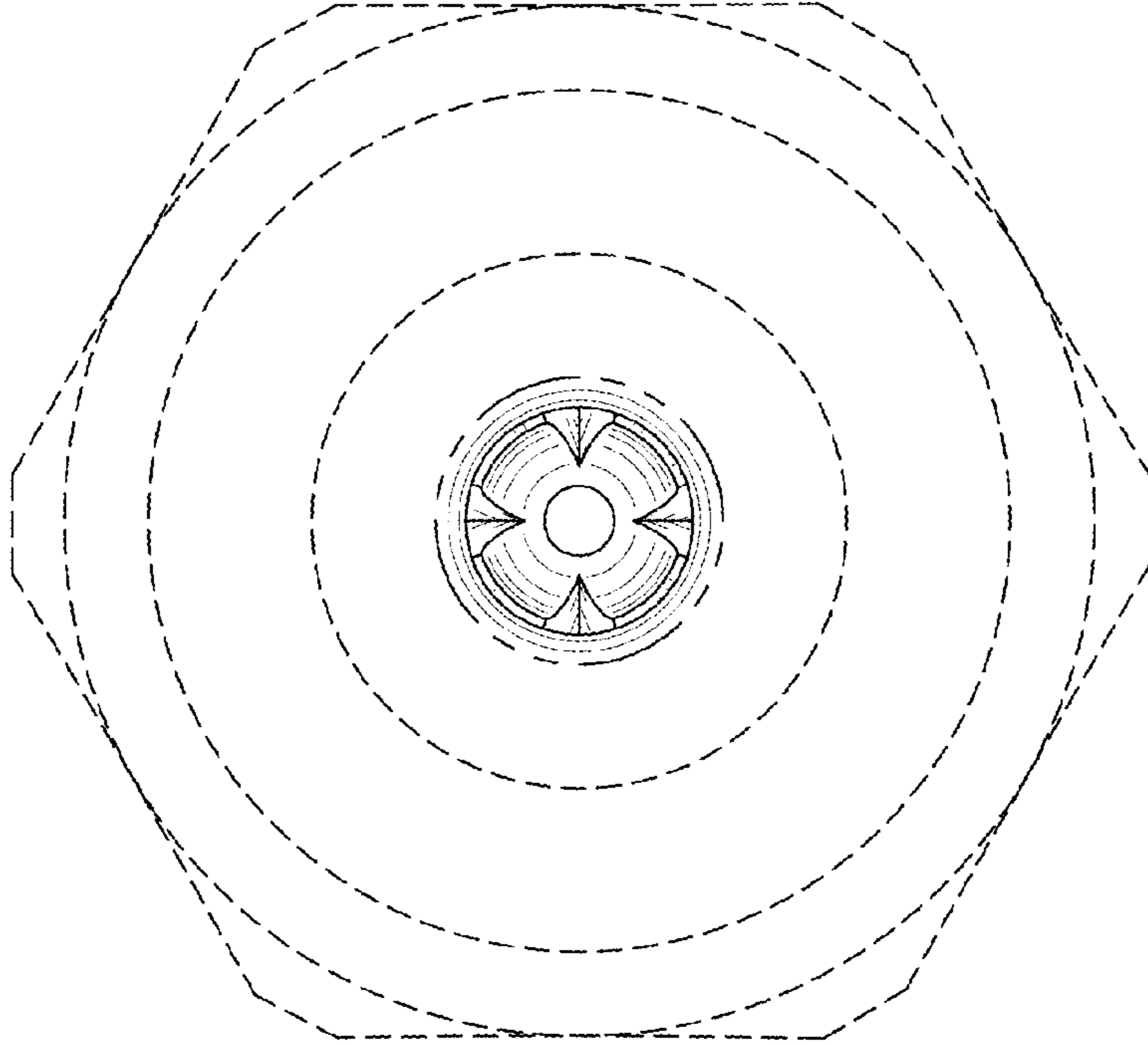

FIG. 7

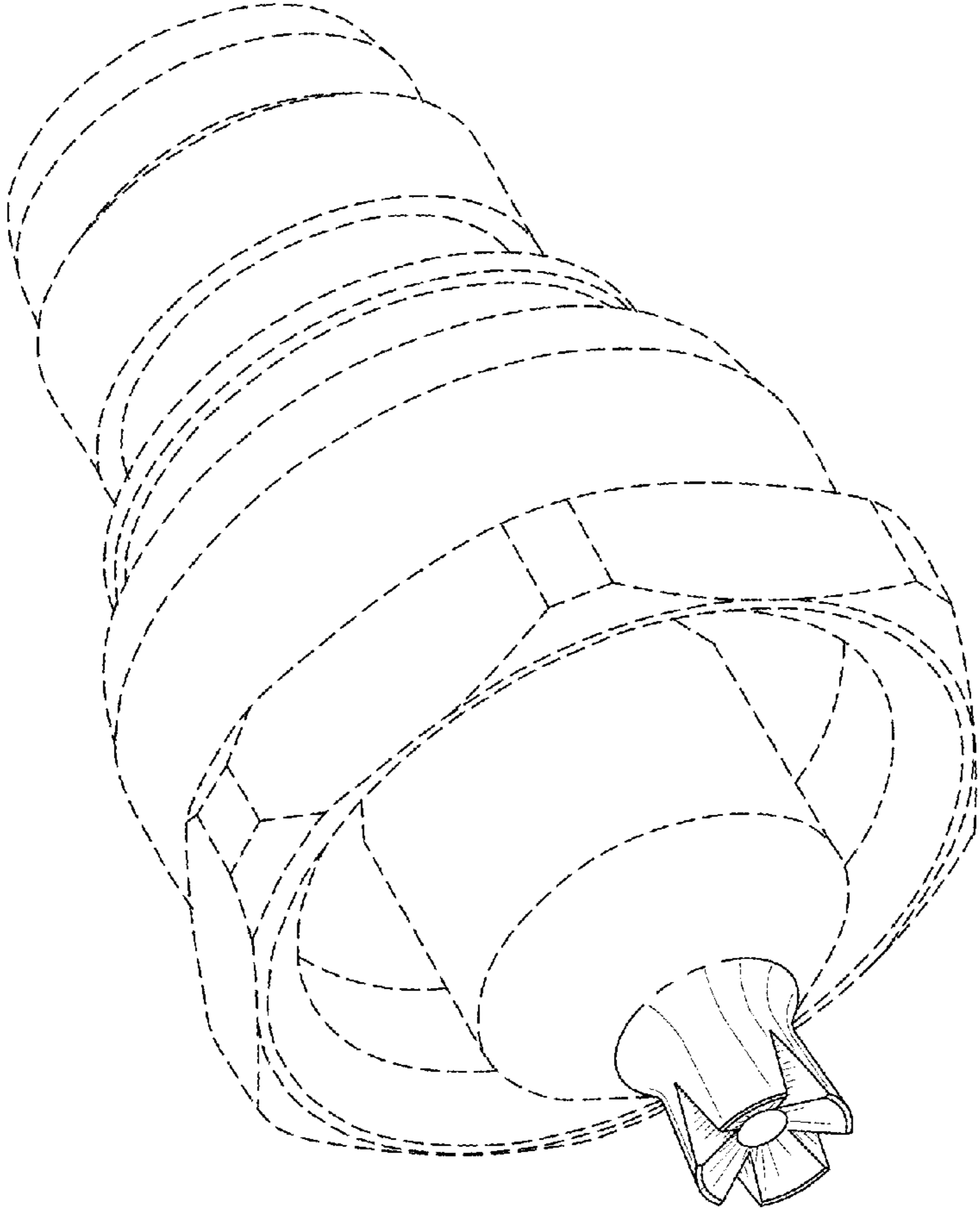

FIG. 8

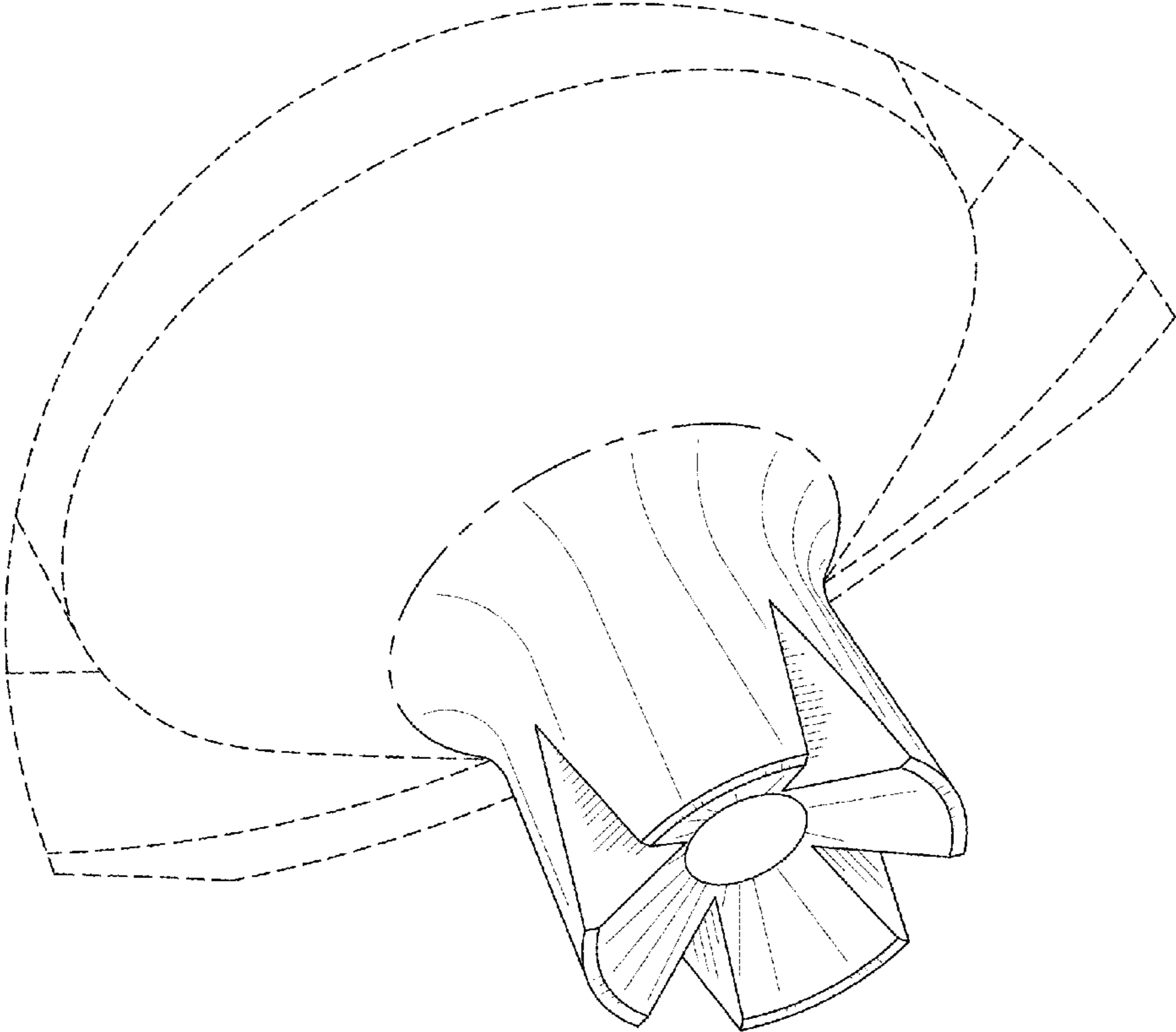

FIG. 9

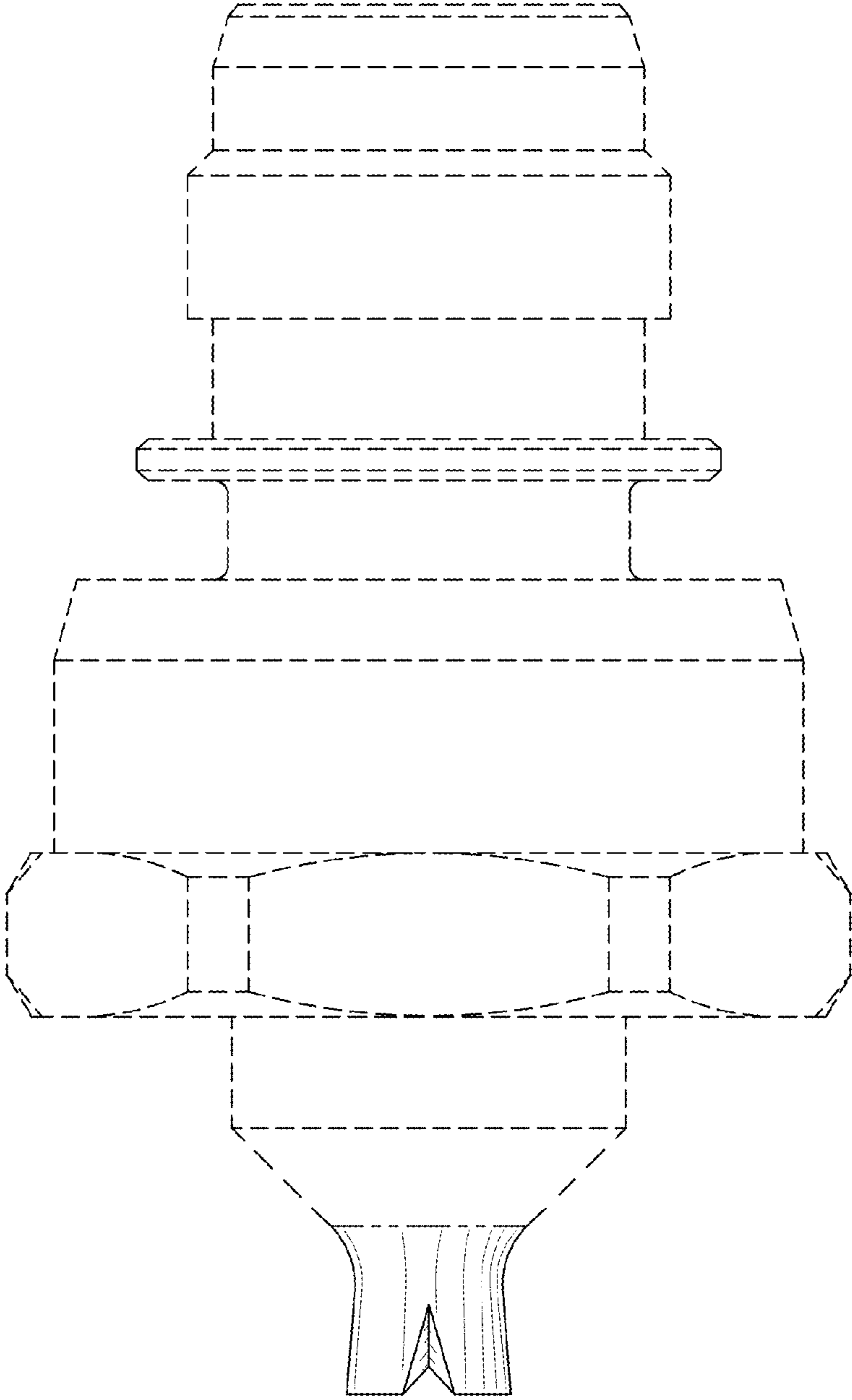

FIG. 10

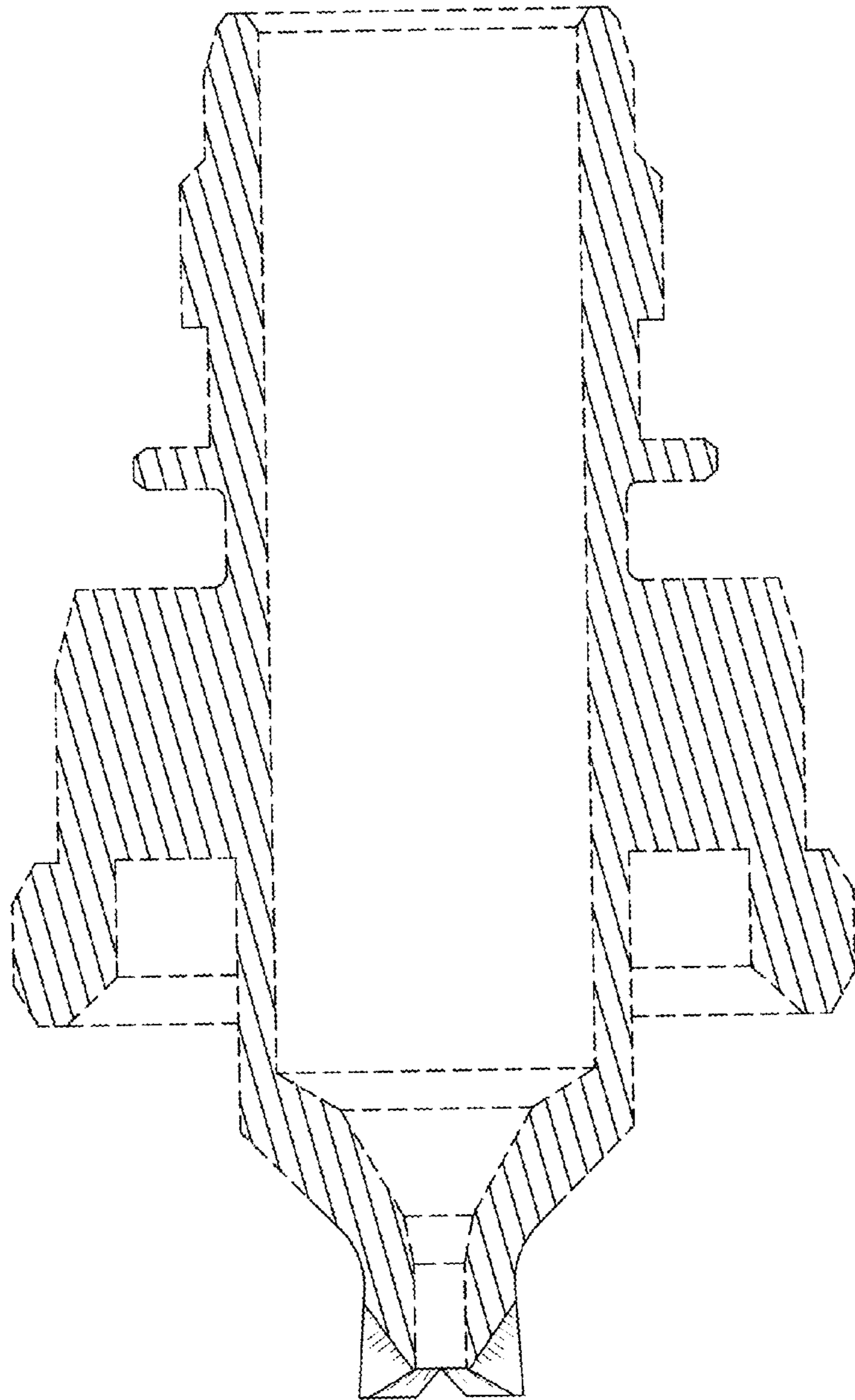

FIG. 11

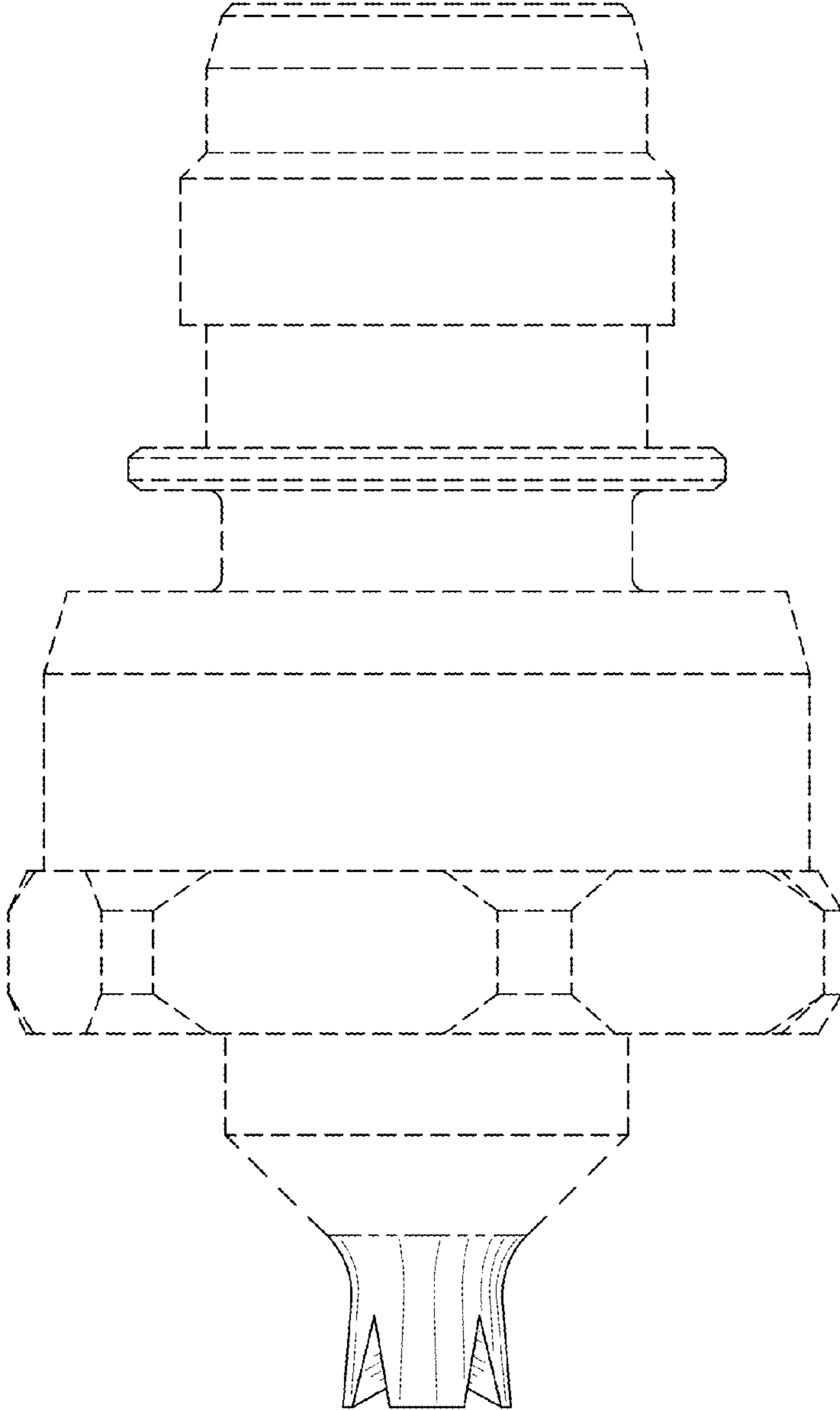

FIG. 12

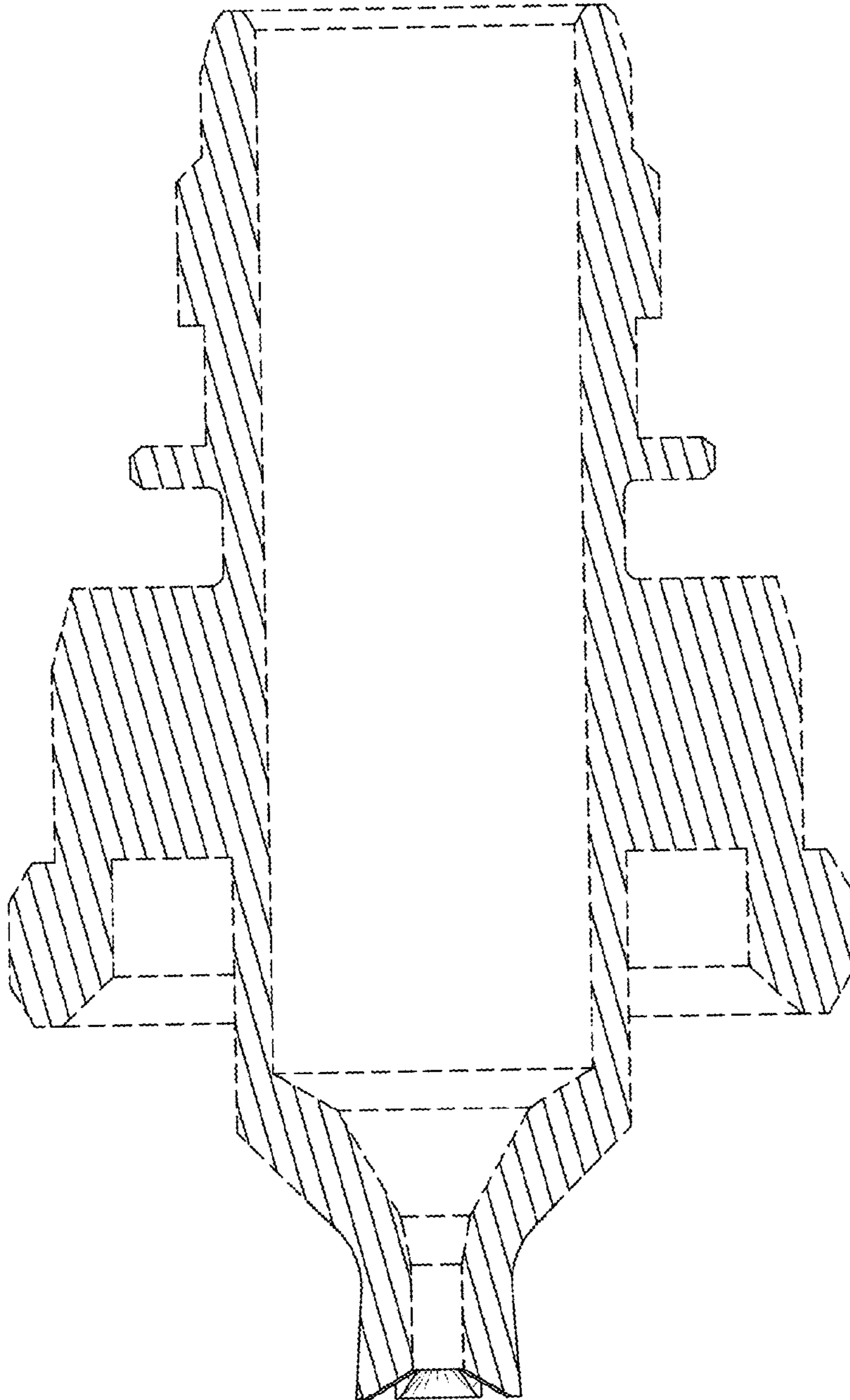

FIG. 13

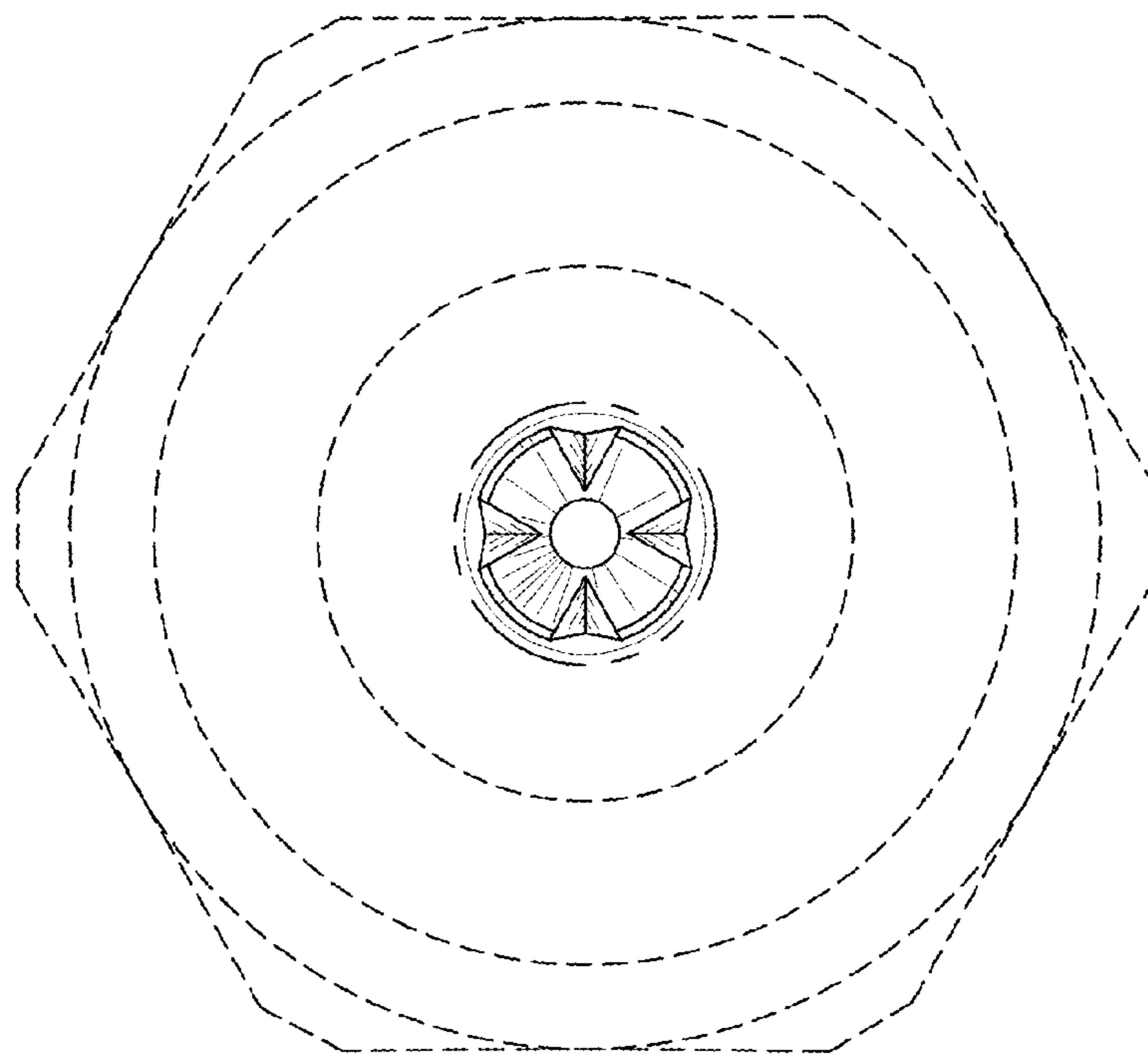

FIG. 14

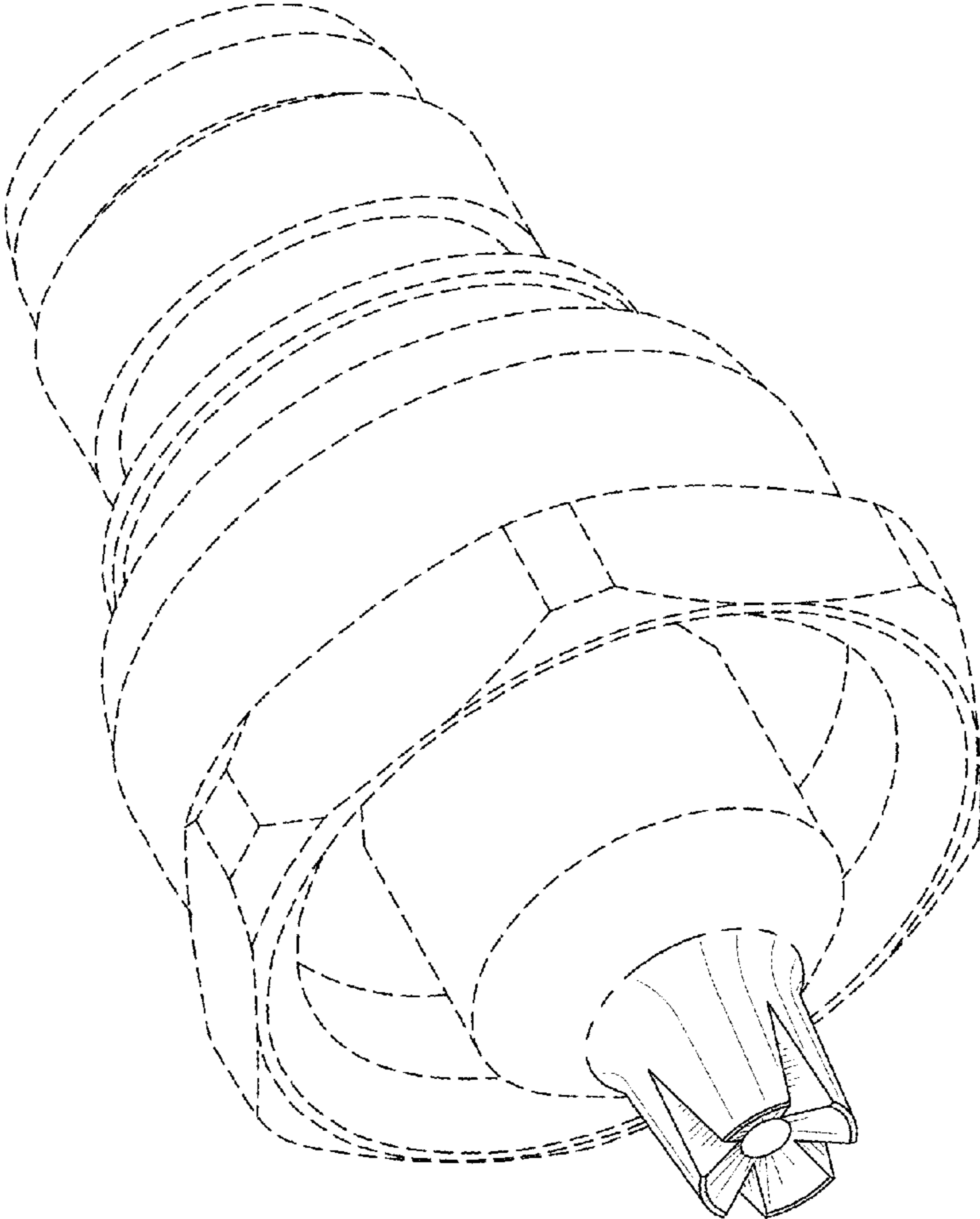

FIG. 15

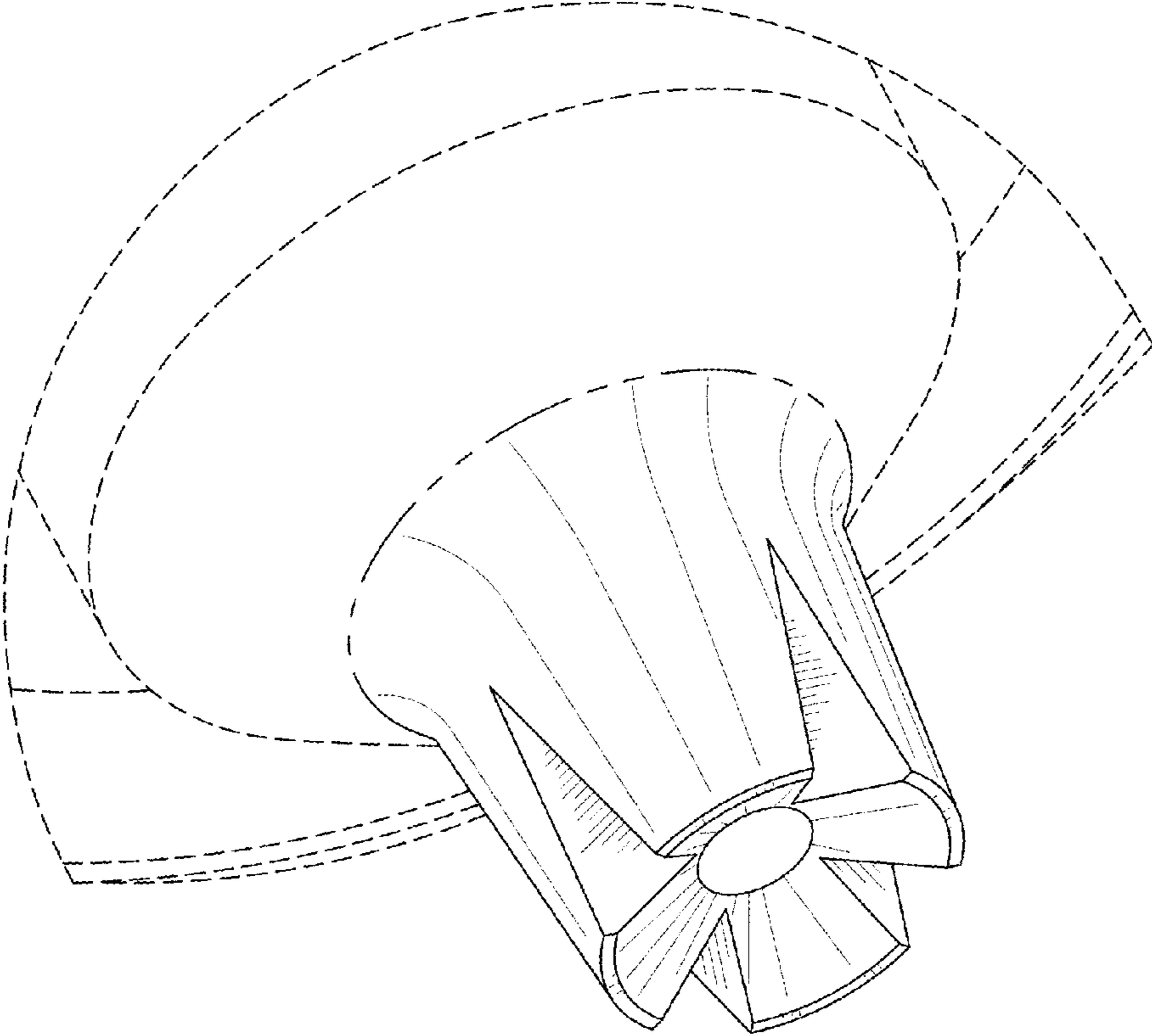

FIG. 16

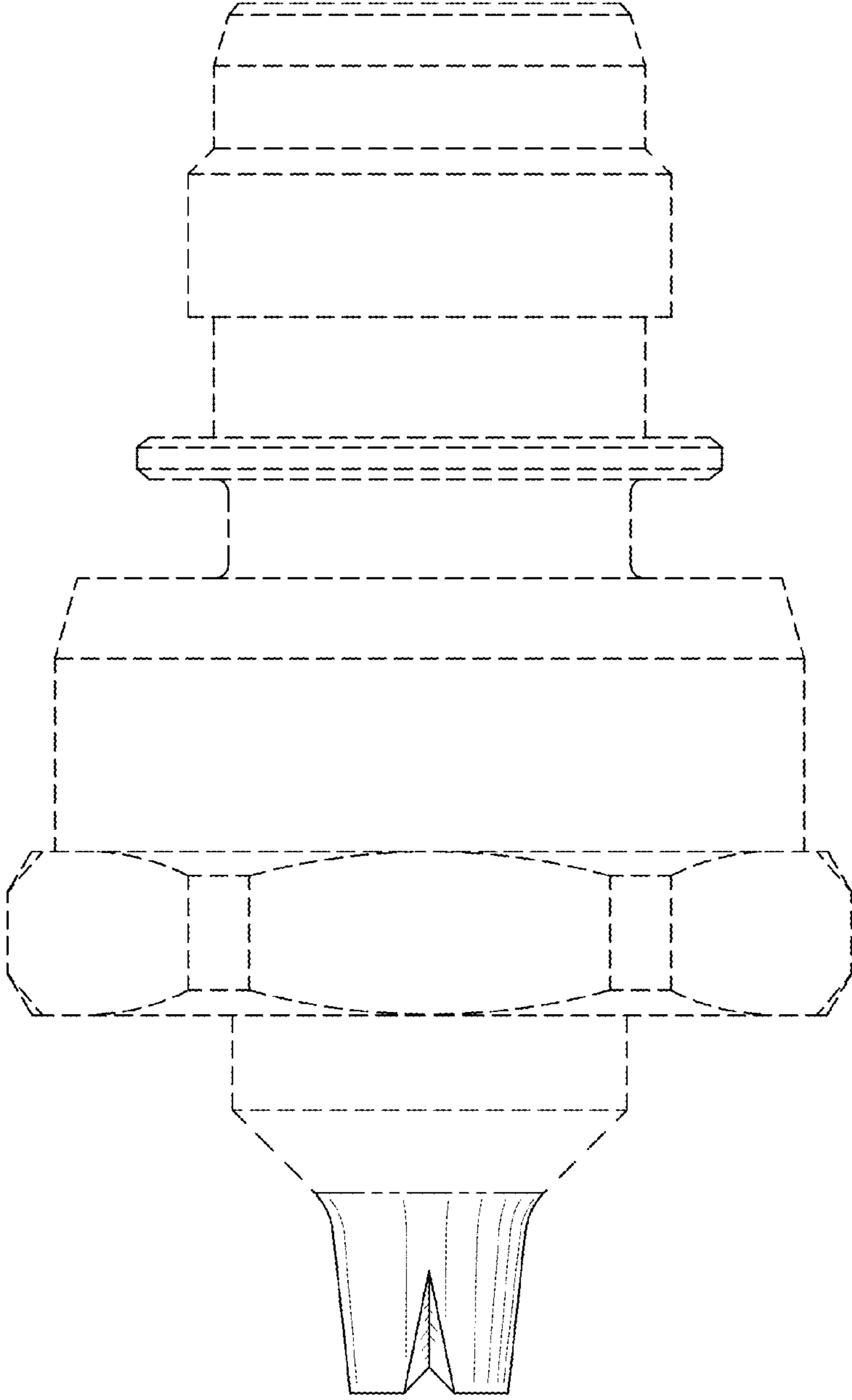

FIG. 17

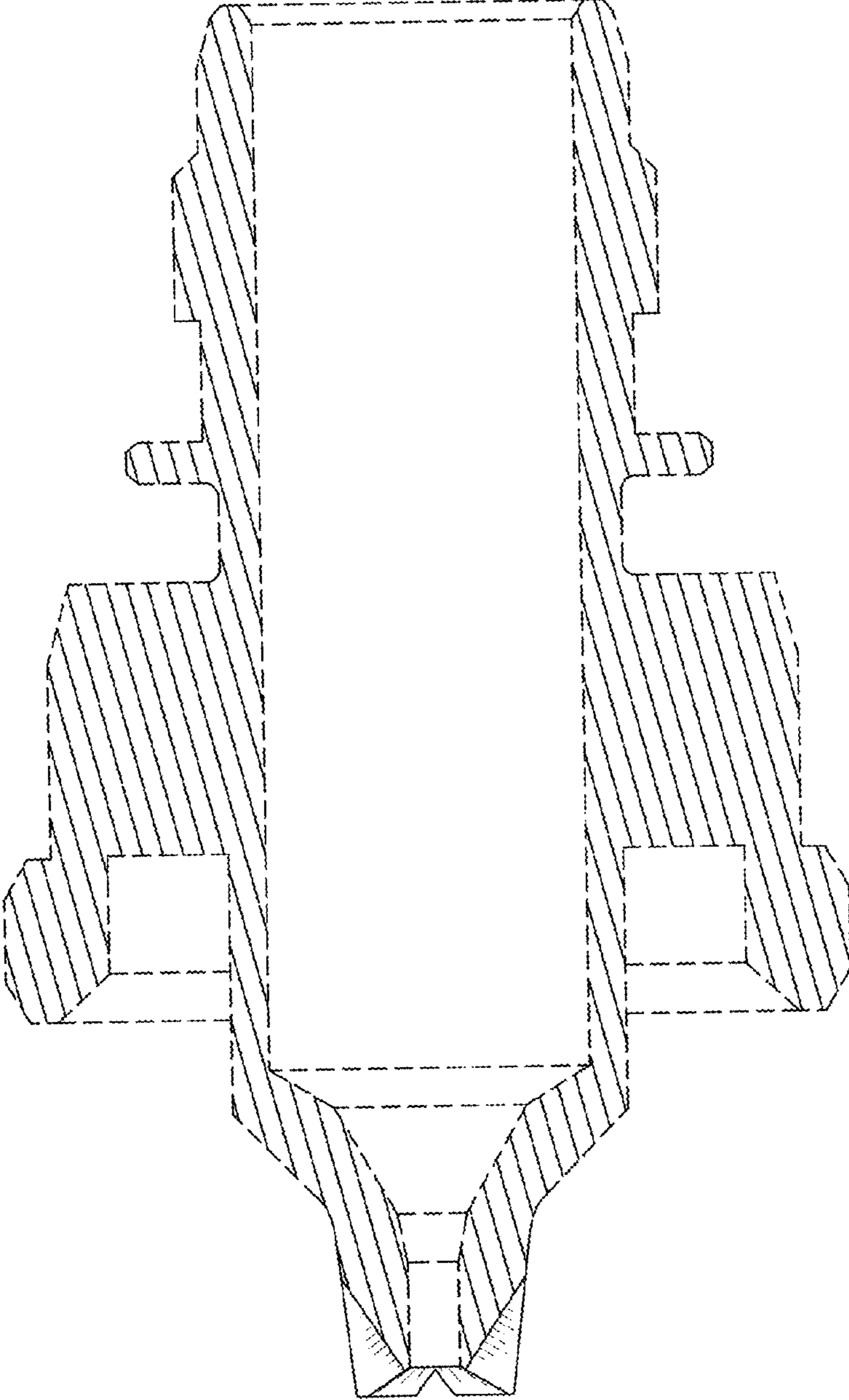

FIG. 18

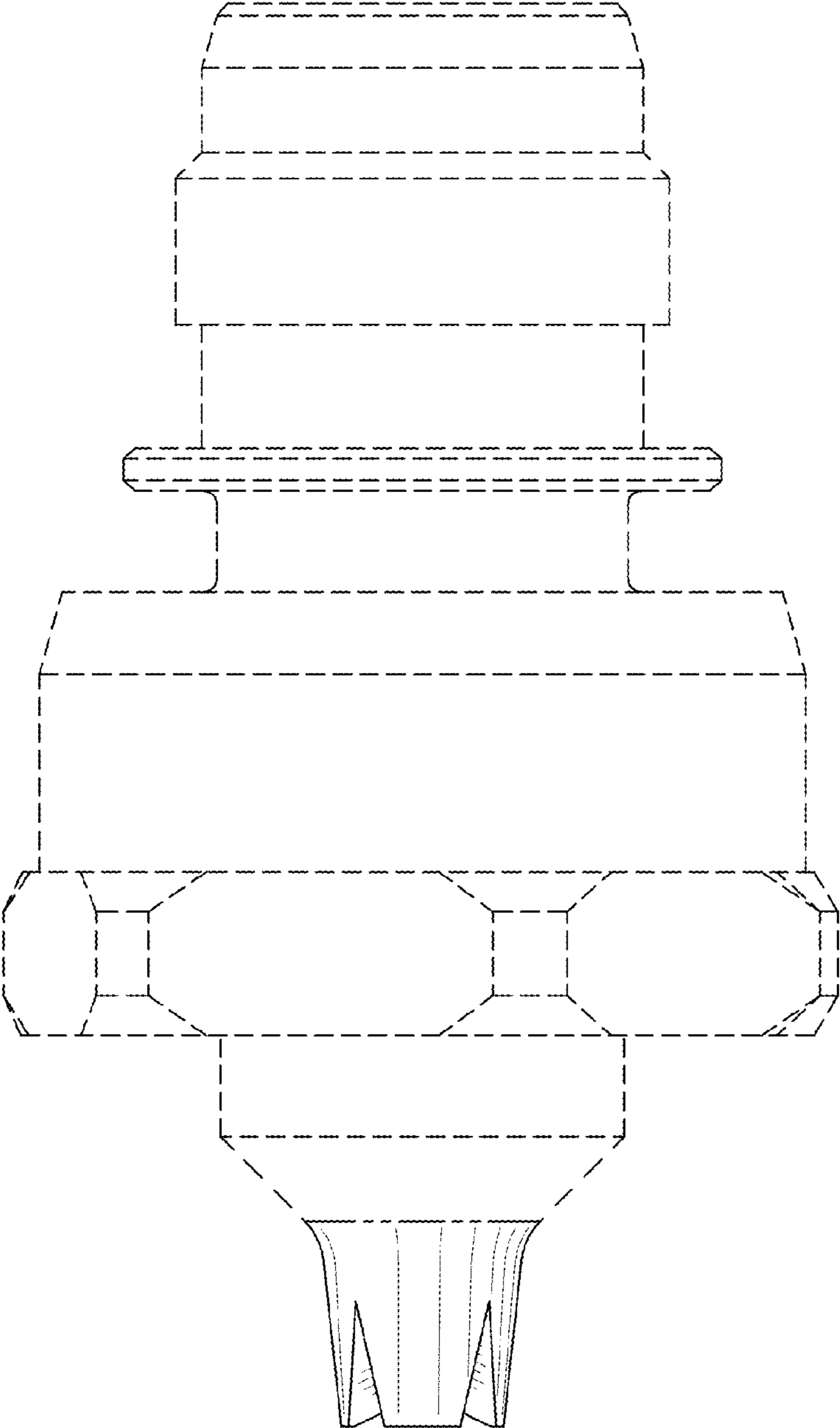

FIG. 19

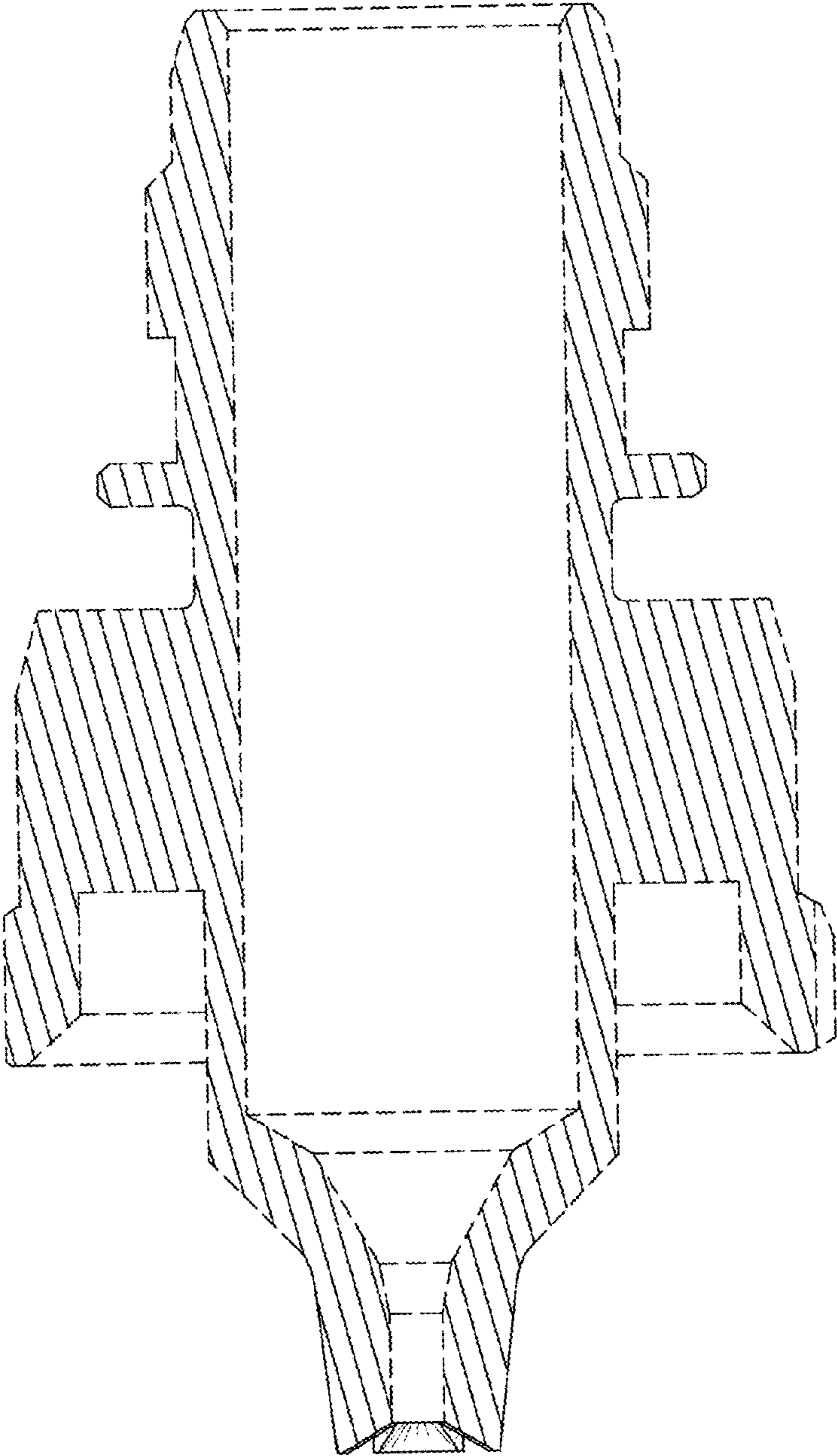

FIG. 20

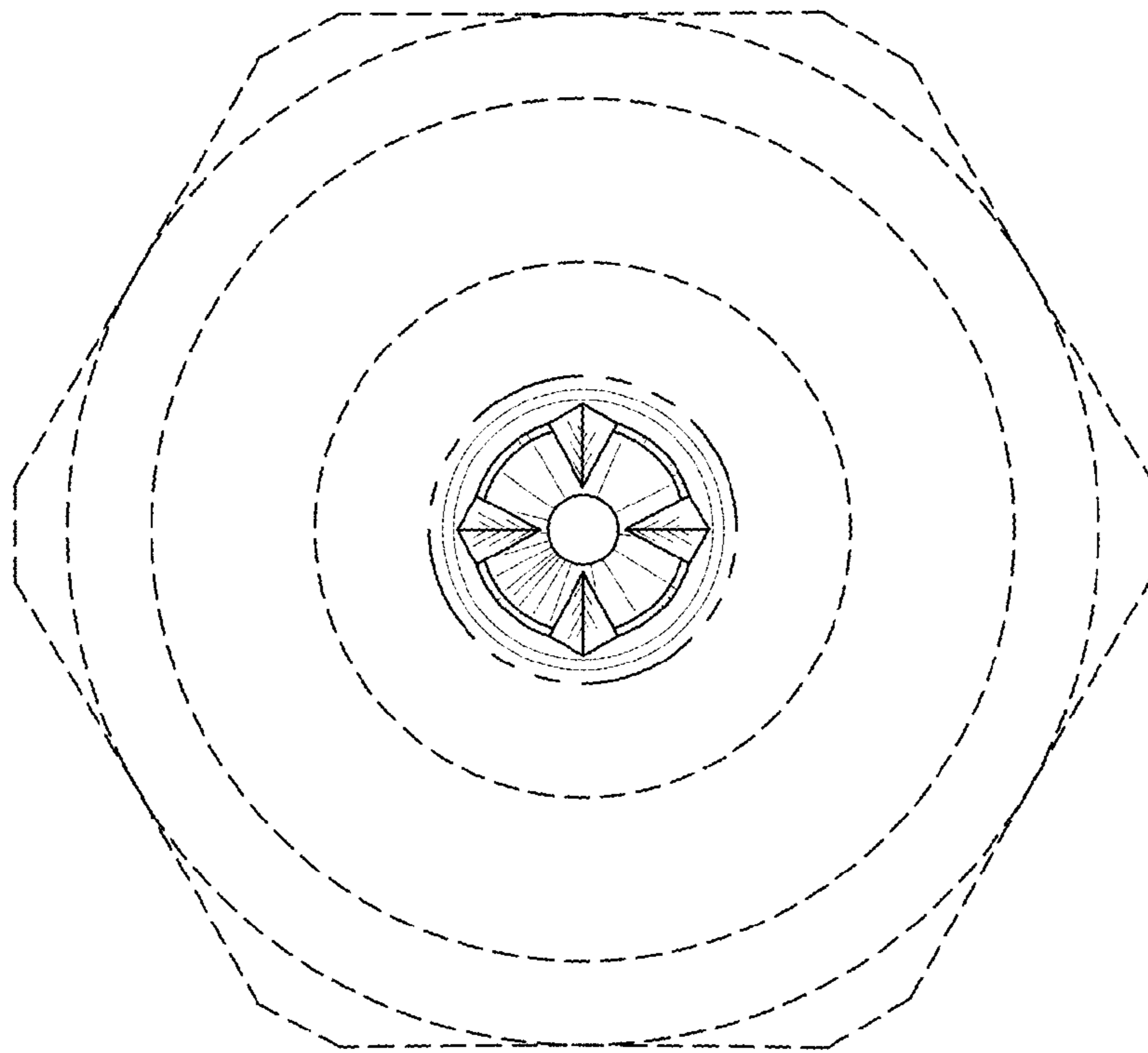

FIG. 21