



US00D755672S

(12) **United States Design Patent**
Joren et al.

(10) **Patent No.:** **US D755,672 S**

(45) **Date of Patent:** **** May 10, 2016**

(54) **ROLLING STOCK**

(71) Applicant: **MITSUBISHI HEAVY INDUSTRIES, LTD.**, Tokyo (JP)

(72) Inventors: **Ichiro Joren**, Tokyo (JP); **Masahisa Masukawa**, Tokyo (JP); **Mitsuaki Hoshi**, Tokyo (JP); **Ryuji Karasawa**, Hiroshima (JP)

(73) Assignee: **MITSUBISHI HEAVY INDUSTRIES, LTD.**, Tokyo (JP)

(**) Term: **14 Years**

(21) Appl. No.: **29/519,262**

(22) Filed: **Mar. 3, 2015**

(51) **LOC (10) Cl.** **12-03**

(52) **U.S. Cl.**
USPC **D12/36**

(58) **Field of Classification Search**
USPC D12/36-51, 320, 195, 345, 99, 1, 82, D12/84; 105/397, 404, 396; D26/69, 70, 72, D26/74, 80, 81, 88, 90
CPC B61D 37/00; B61D 17/045; B61D 17/00; B61D 17/12; B61D 29/00; B61D 17/041; B61D 17/04; B61D 1/00; B61D 13/00; B61D 17/043; B61D 17/005; B61D 19/00; B61F 5/245; B60Q 3/025; B60Q 3/0256; B60Q 3/0289; B60Q 3/02

See application file for complete search history.

(56) **References Cited**

U.S. PATENT DOCUMENTS

D206,838 S *	1/1967	Hawes	D12/37
4,313,383 A *	2/1982	Parazader	E01D 19/125 104/118
D320,581 S *	10/1991	Gallitzendorfer	D12/37
D331,033 S *	11/1992	Renfrew	D12/40
D421,581 S *	3/2000	Dimson	D12/37
D514,982 S *	2/2006	Meissner	D12/37
2015/0329124 A1 *	11/2015	Kuroda	B61D 17/08 105/413

* cited by examiner

Primary Examiner — T. Chase Nelson

Assistant Examiner — Ania Aman

(74) *Attorney, Agent, or Firm* — Kanesaka Berner and Partners LLP

(57) **CLAIM**

The ornamental design for a rolling stock, as shown and described.

DESCRIPTION

FIG. 1 is a perspective view of a rolling stock bearing the design.

FIG. 2 is a front elevation view of the rolling stock. A rear elevation view of the rolling stock appears identical to the front elevation view.

FIG. 3 is a left side elevation view of the rolling stock. A right side elevation view of the rolling stock appears identical to the left side elevation view; and,

FIG. 4 is a top plan view of the rolling stock.

The broken lines shown in the drawings illustrate portions of the rolling stock that form no part of the claimed design. The bottom view forms no part of the claimed design.

1 Claim, 4 Drawing Sheets

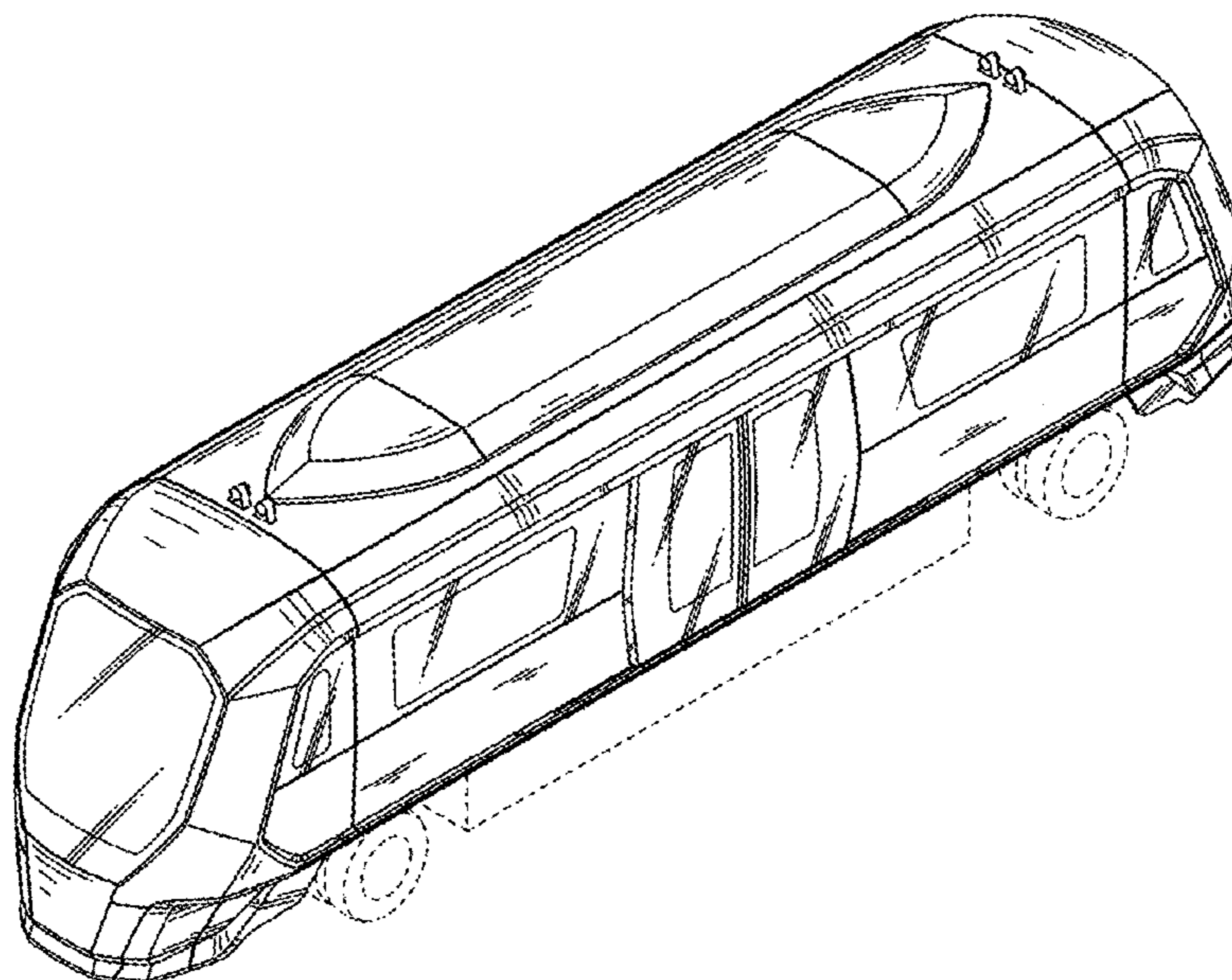

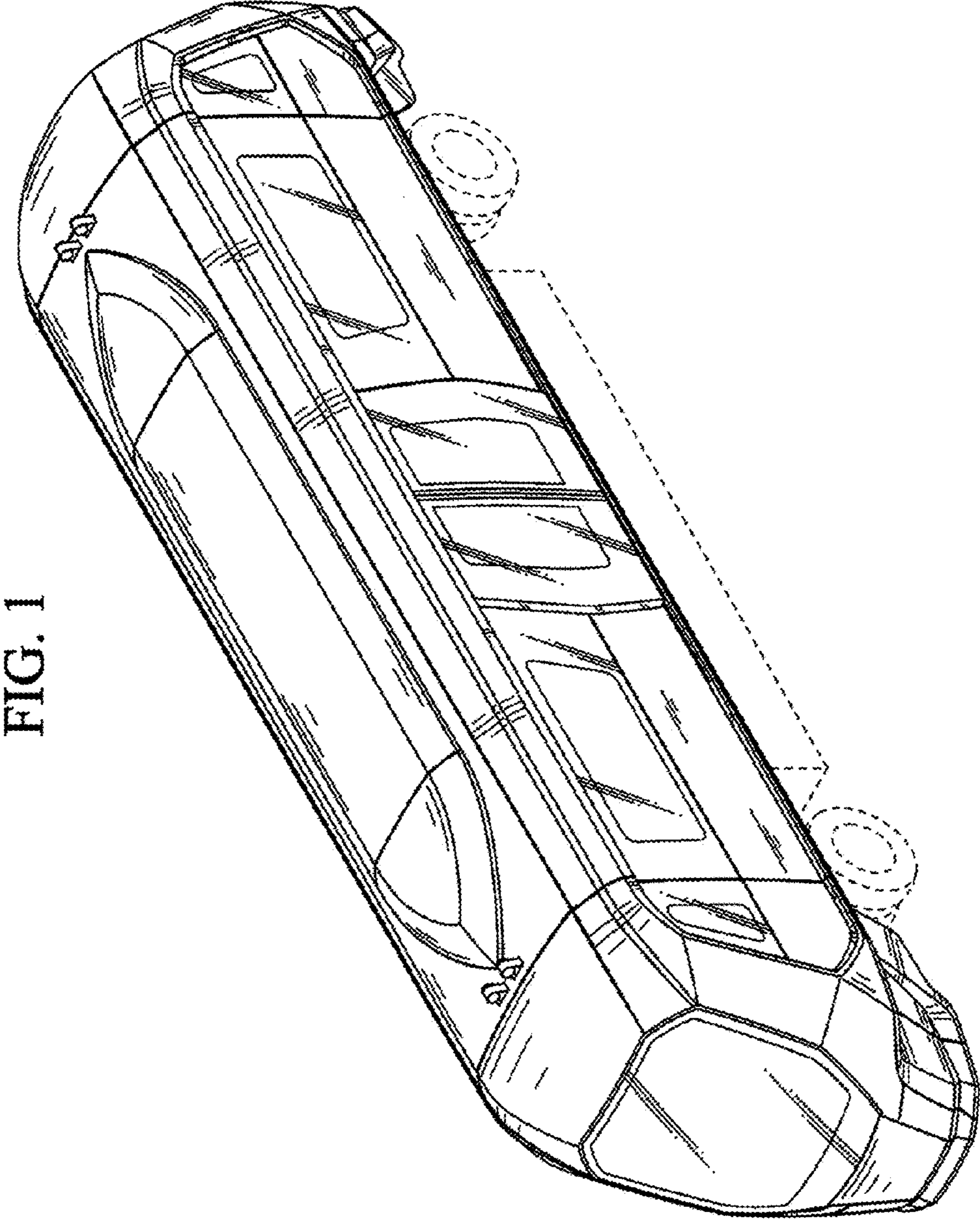

FIG. 1

FIG. 2

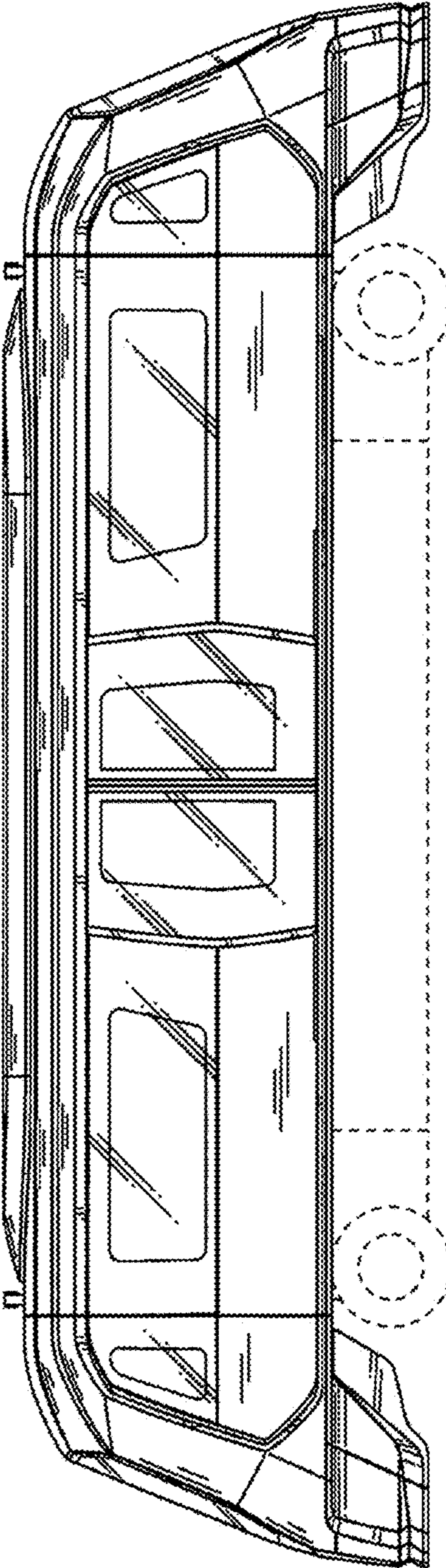

FIG. 3

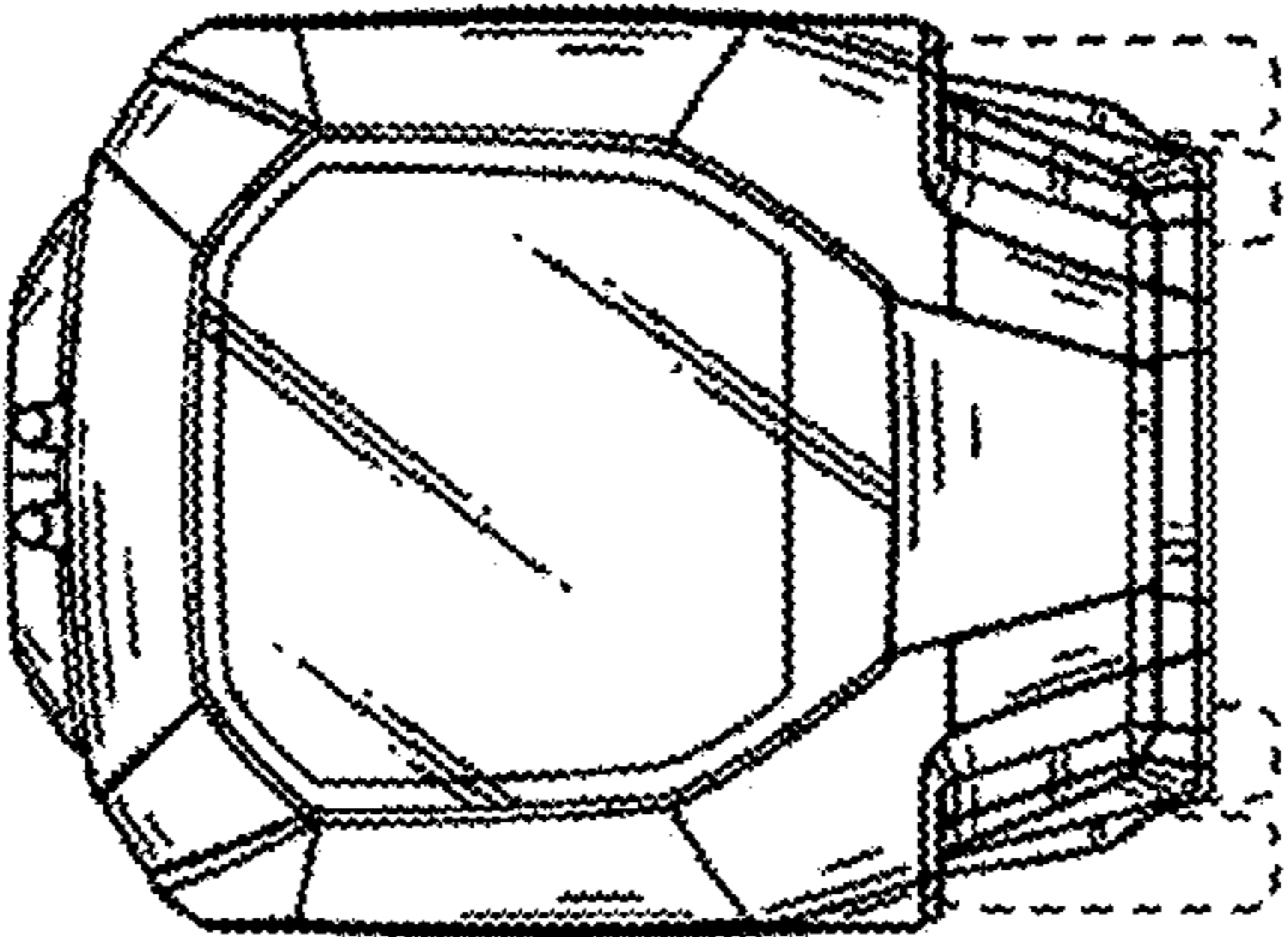
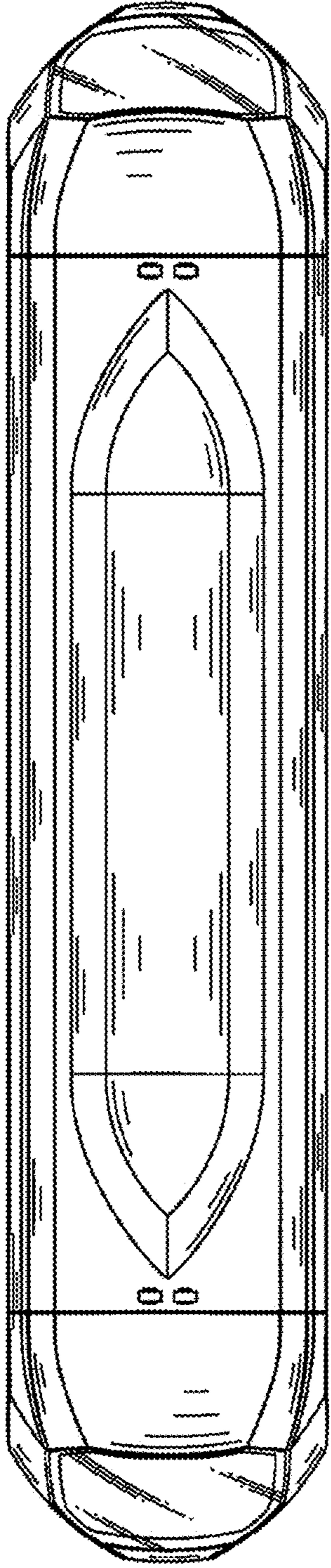

FIG. 4



UNITED STATES PATENT AND TRADEMARK OFFICE
CERTIFICATE OF CORRECTION

PATENT NO. : D755,672 S
APPLICATION NO. : 29/519262
DATED : May 10, 2016
INVENTOR(S) : Ichiro Joren et al.

Page 1 of 1

It is certified that error appears in the above-identified patent and that said Letters Patent is hereby corrected as shown below:

Title page, item (30) insert

--(30) Foreign Application Priority Data
September 4, 2014 (JP) 2014-019509 --

Signed and Sealed this
Twenty-seventh Day of September, 2016



Michelle K. Lee
Director of the United States Patent and Trademark Office