



US00D755581S

(12) **United States Design Patent**
Garman

(10) **Patent No.:** **US D755,581 S**
(45) **Date of Patent:** **** May 10, 2016**

- (54) **JUICER** 5,970,859 A * 10/1999 Lee A47J 19/022
99/506
- (71) Applicant: **Hamilton Beach Brands, Inc.**, Glen
Allen, VA (US) D419,398 S 1/2000 Shih
D422,184 S * 4/2000 Kao D7/666
6,155,164 A 12/2000 Egana et al.
D447,390 S * 9/2001 Lee D7/666
6,295,921 B1 * 10/2001 Stoev A47J 19/022
100/125
- (72) Inventor: **Michael Garman**, Moseley, VA (US) 6,318,252 B1 * 11/2001 Kao A47J 19/022
100/125
- (73) Assignee: **Hamilton Beach Brands, Inc.**, Glen
Allen, VA (US) 6,321,644 B1 11/2001 Kae
6,435,080 B1 8/2002 Zarlengo
6,564,705 B2 * 5/2003 Zarlengo A47J 19/005
100/245
- (**) Term: **14 Years**
- (21) Appl. No.: **29/518,132** 6,988,447 B1 1/2006 Horng
2007/0125244 A1 6/2007 Hensel
2013/0192711 A1 8/2013 Sessler
- (22) Filed: **Feb. 20, 2015**
- (51) **LOC (10) Cl.** **07-04** * cited by examiner
- (52) **U.S. Cl.**
USPC **D7/666**
- (58) **Field of Classification Search**
USPC D7/665, 666, 368, 669
CPC A47J 19/022; A47J 19/02; A47J 19/025;
A23N 1/00; A23N 1/003
See application file for complete search history.

Primary Examiner — Terry Wallace
(74) *Attorney, Agent, or Firm* — Alexander D. Raring

(57) **CLAIM**
The ornamental design for a juicer, as shown and described.

DESCRIPTION

FIG. 1 is a perspective view as seen from the top, front and right side of juicer showing the new design;
FIG. 2 is a front view thereof;
FIG. 3 is a rear view thereof;
FIG. 4 is a left side view thereof;
FIG. 5 is a right side view thereof;
FIG. 6 is a top view thereof; and,
FIG. 7 is a bottom view thereof.
Any broken line illustration of the structure in the drawings is not part of the claimed design.

1 Claim, 7 Drawing Sheets

- (56) **References Cited**
U.S. PATENT DOCUMENTS
- D92,537 S * 6/1934 Johnson D7/666
2,090,913 A * 8/1937 Johnson A47J 19/022
100/125
2,151,500 A * 3/1939 Cecil A47J 19/022
100/131
2,553,942 A * 5/1951 Roos A47J 19/022
100/125
2,703,522 A * 3/1955 Smith A47J 19/022
100/213
D304,140 S * 10/1989 Li D7/666
D370,837 S * 6/1996 Lee D7/666

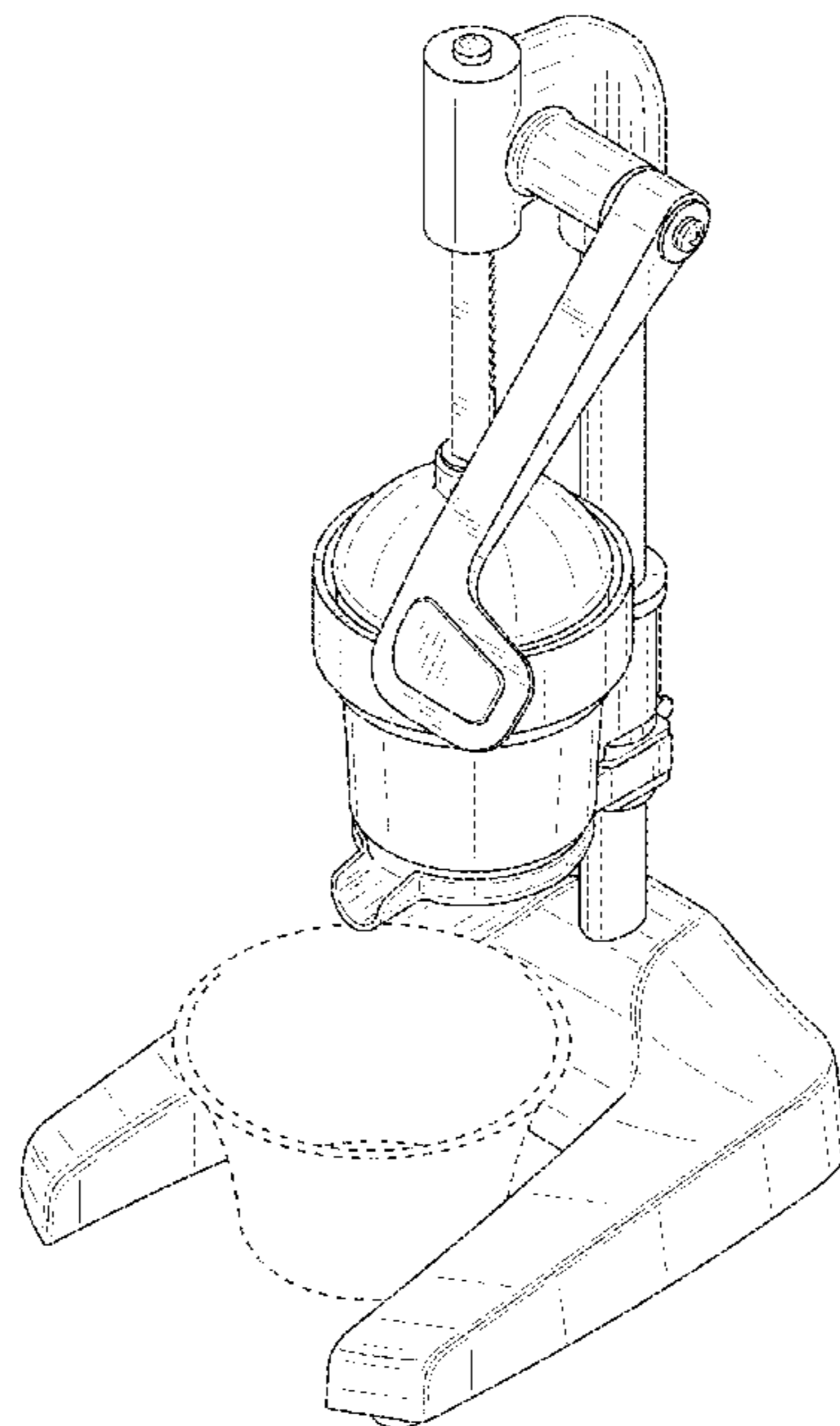

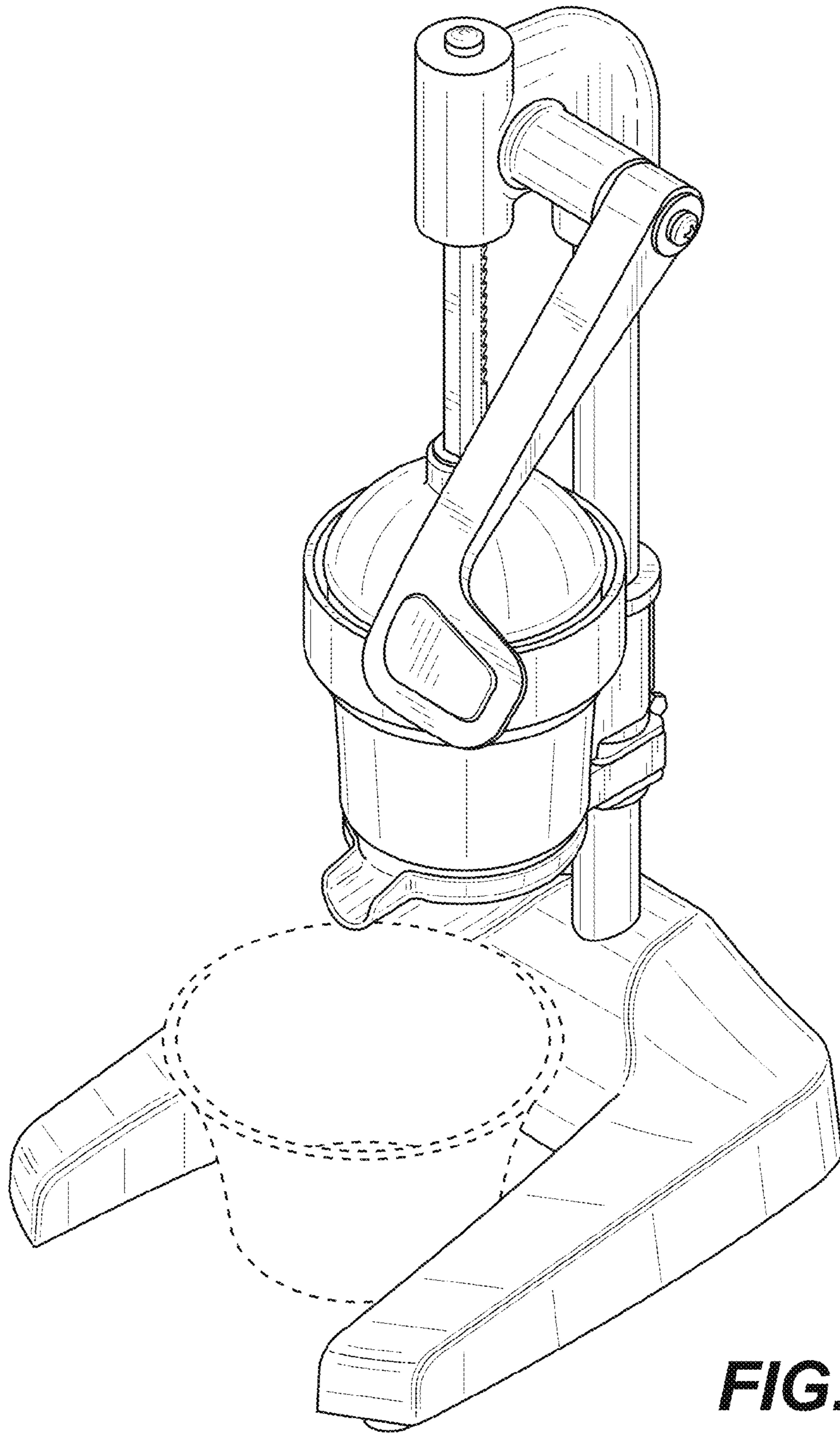

FIG. 1

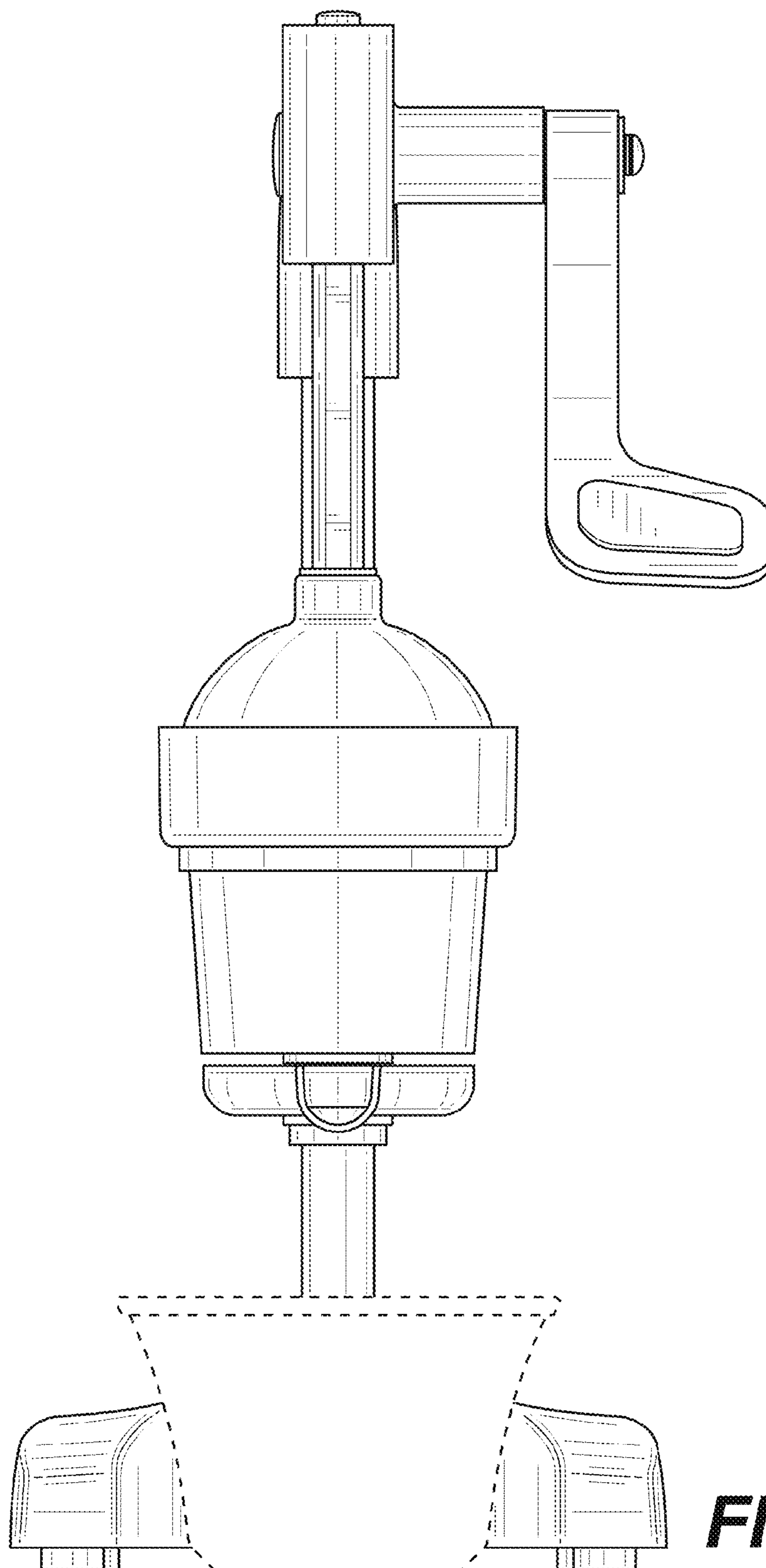

FIG. 2

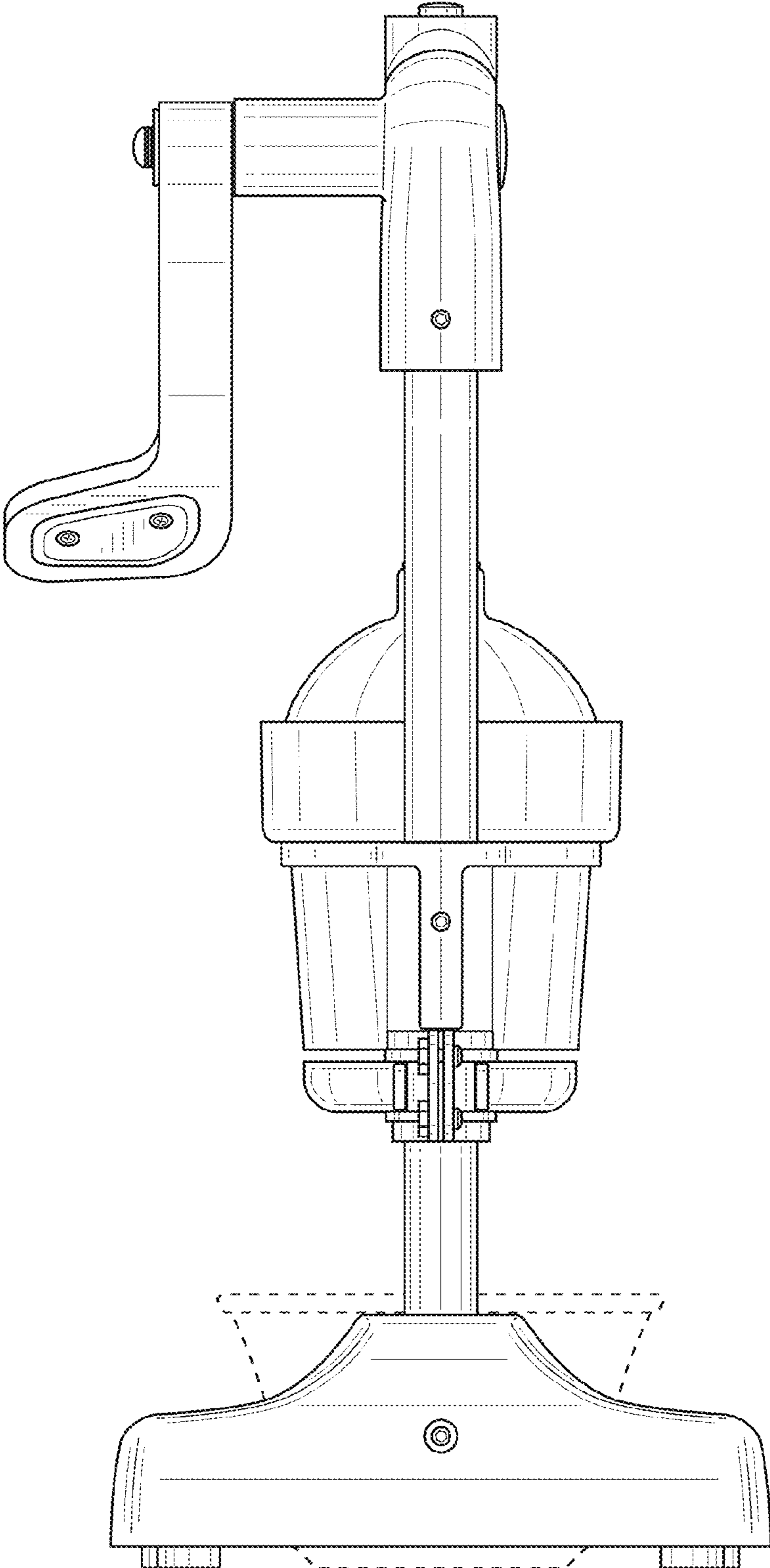

FIG. 3

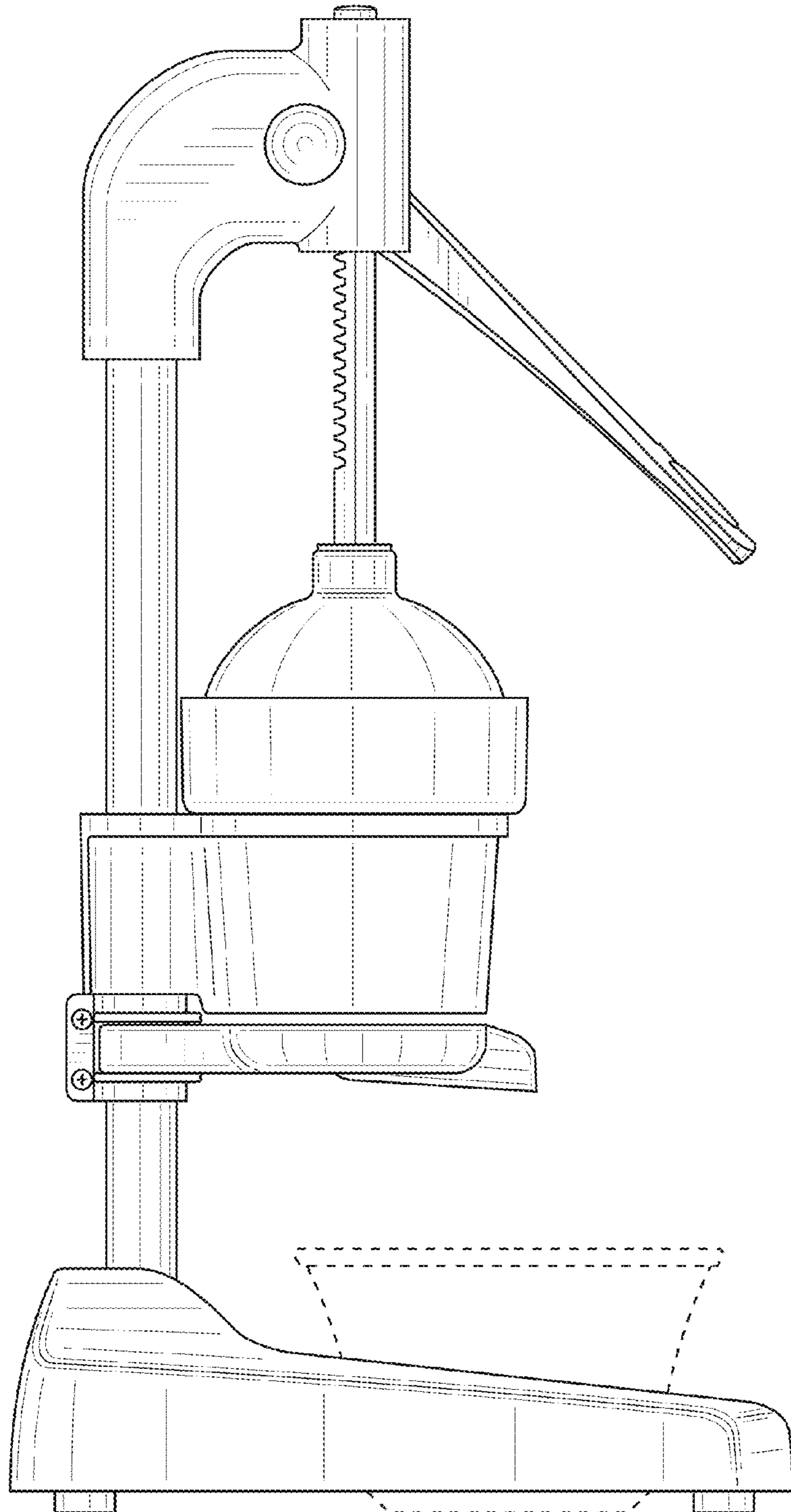

FIG. 4

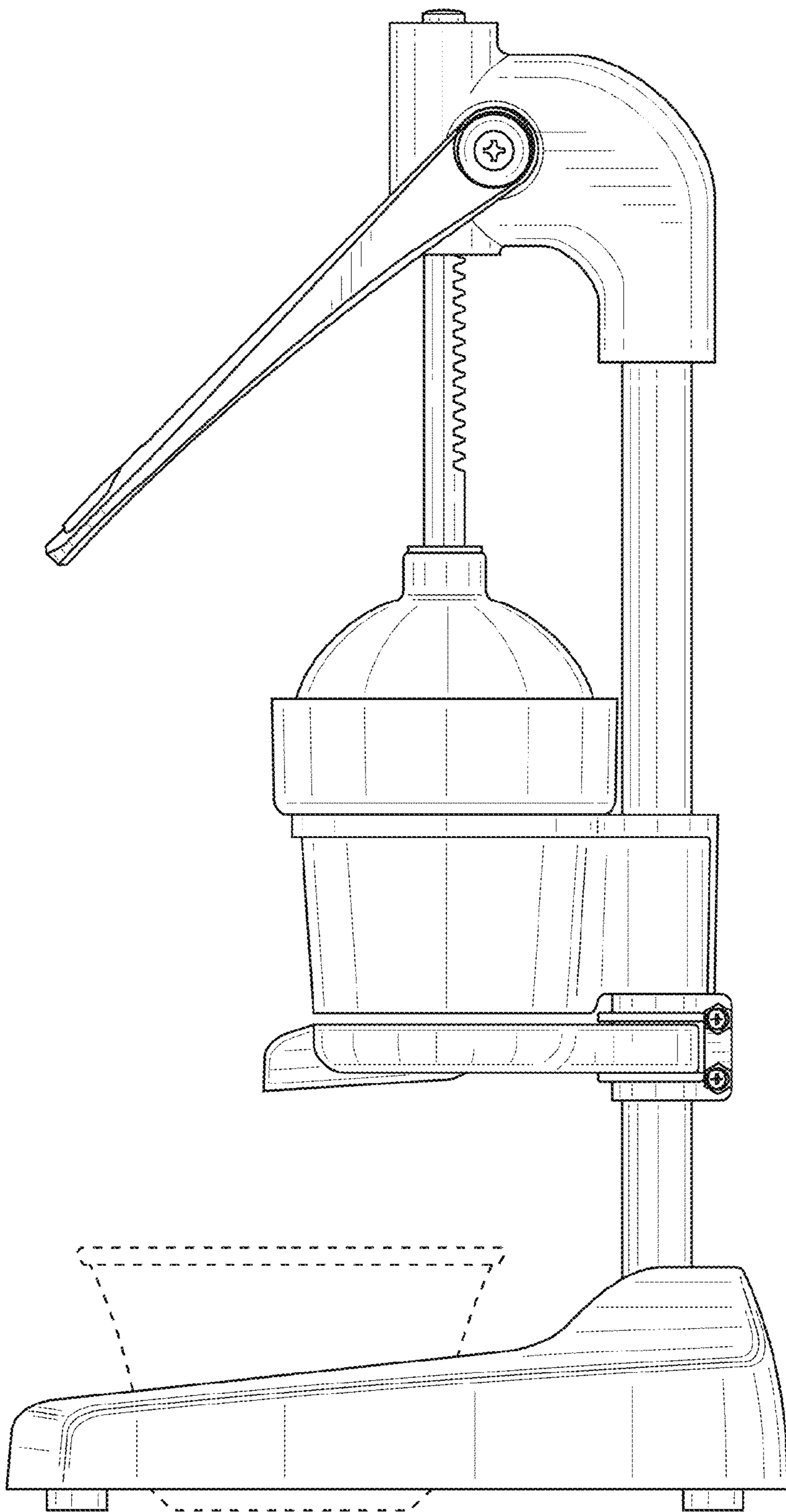

FIG. 5

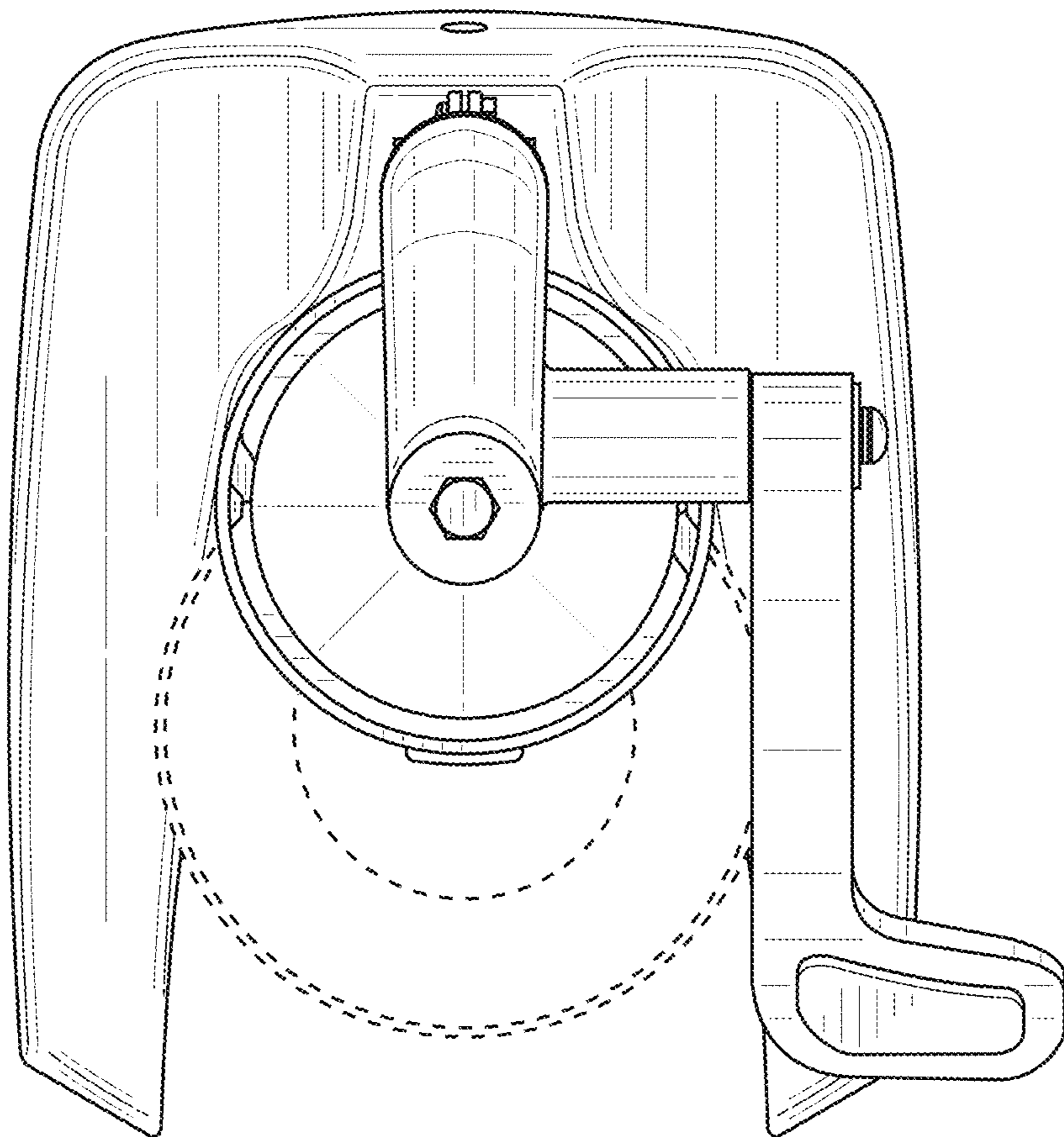

FIG. 6

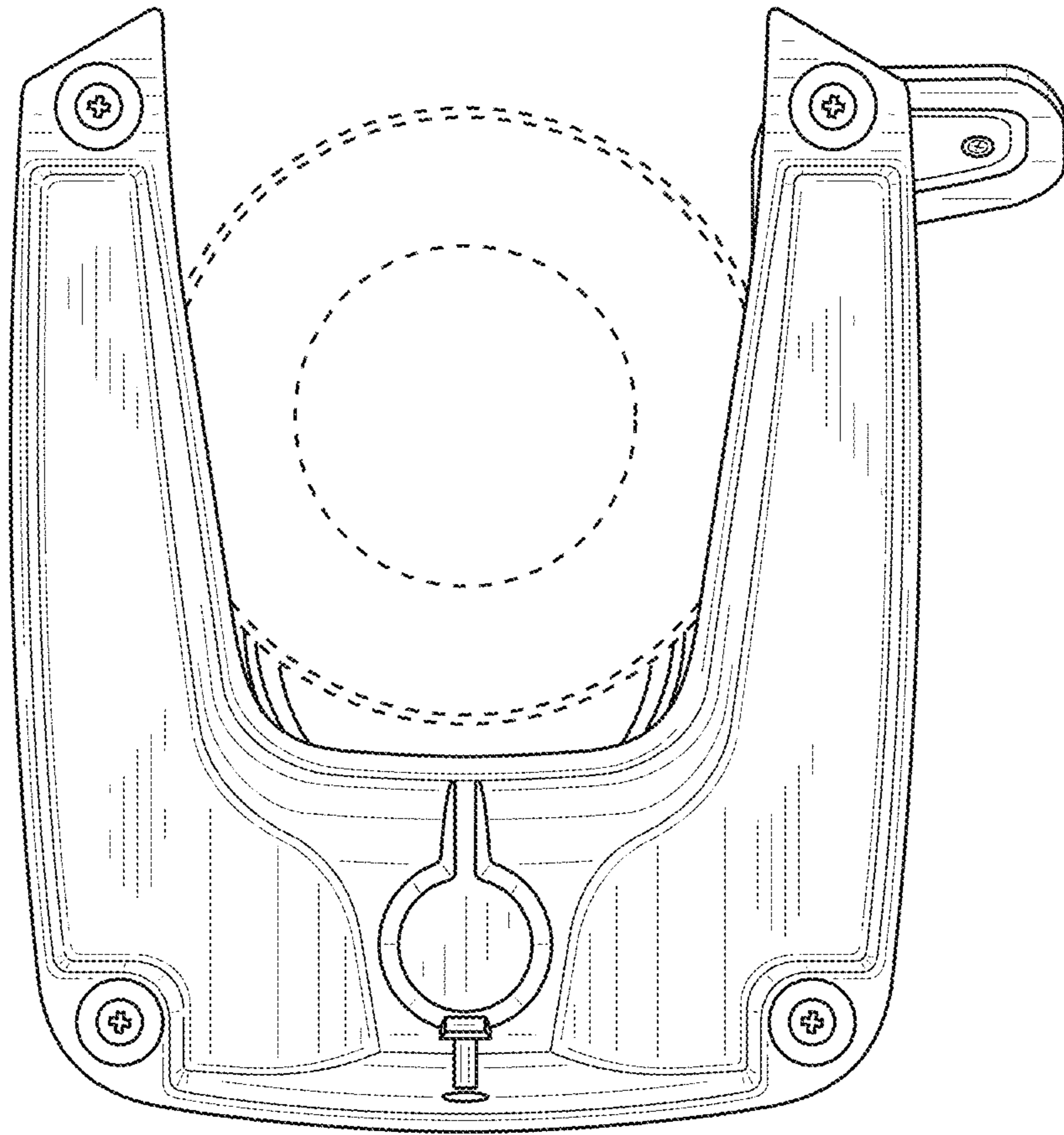

FIG. 7