



US00D755426S

(12) **United States Design Patent**
Handt et al.

(10) **Patent No.:** **US D755,426 S**

(45) **Date of Patent:** **** May 3, 2016**

(54) **HEADLIGHT FOR A VEHICLE**

D582,587 S * 12/2008 Yang D26/28
D593,232 S * 5/2009 Koman D26/28
D635,694 S * 4/2011 Yang D26/28

(71) Applicant: **Daimler AG**, Stuttgart (DE)

* cited by examiner

(72) Inventors: **Stefan Handt**, Stuttgart (DE); **Robert Lesnik**, Leonberg (DE); **Gorden Wagener**, Gaeufelden (DE)

Primary Examiner — Marcus Jackson

(74) *Attorney, Agent, or Firm* — Crowell & Moring LLP

(73) Assignee: **Daimler AG**, Stuttgart (DE)

(57) **CLAIM**

The ornamental design for a headlight for a vehicle, as shown and described.

(**) Term: **14 Years**

DESCRIPTION

(21) Appl. No.: **29/517,178**

This application contains subject matter related to the following co-pending U.S. design patent applications:

(22) Filed: **Feb. 11, 2015**

Application Ser. No. 29/515,462, filed Jul. 23, 2015 and entitled "Vehicle, Toy, and/or Replicas Thereof;"

(30) **Foreign Application Priority Data**

Aug. 12, 2014 (WO) DM/084 156

Application Ser. No. 29/515,464, filed Jul. 23, 2015 and entitled "Front Portion of a Vehicle, Toy, and/or Replicas Thereof;"

(51) **LOC (10) CL.** **26-06**

Application Ser. No. 29/517,179, filed herewith and entitled "Headlight for a Vehicle"; and

(52) **U.S. CL.**

USPC **D26/28**

Application Ser. No. 29/517,180, filed herewith and entitled "Headlight for a Vehicle".

(58) **Field of Classification Search**

USPC D26/28-36; 362/459-468, 475-478, 362/485-487

FIG. 1 is a right perspective view of a first embodiment of a headlight for a vehicle according to the design;

CPC F21S 48/00; F21S 48/10; F21S 48/115;

FIG. 2 is a right side view thereof; and

F21S 48/225; F21S 48/1233; F21S 48/1266;

FIG. 3 is a front view thereof.

F21S 48/1388; F21S 48/2268; F21V 21/04

FIG. 4 is a left perspective view of a second embodiment of the headlight for a vehicle thereof, with the headlight for a vehicle for the opposite side of the vehicle being depicted in the first embodiment;

See application file for complete search history.

FIG. 5 is a left side view thereof; and,

(56) **References Cited**

U.S. PATENT DOCUMENTS

FIG. 6 is a front view thereof.

The broken lines are for illustrative purposes only and form no part of the claimed design.

D538,956 S * 3/2007 Ishii D26/28

D544,614 S * 6/2007 Markefka D26/28

D561,358 S * 2/2008 Tachibana D26/28

D570,007 S * 5/2008 Hsu D26/28

1 Claim, 4 Drawing Sheets

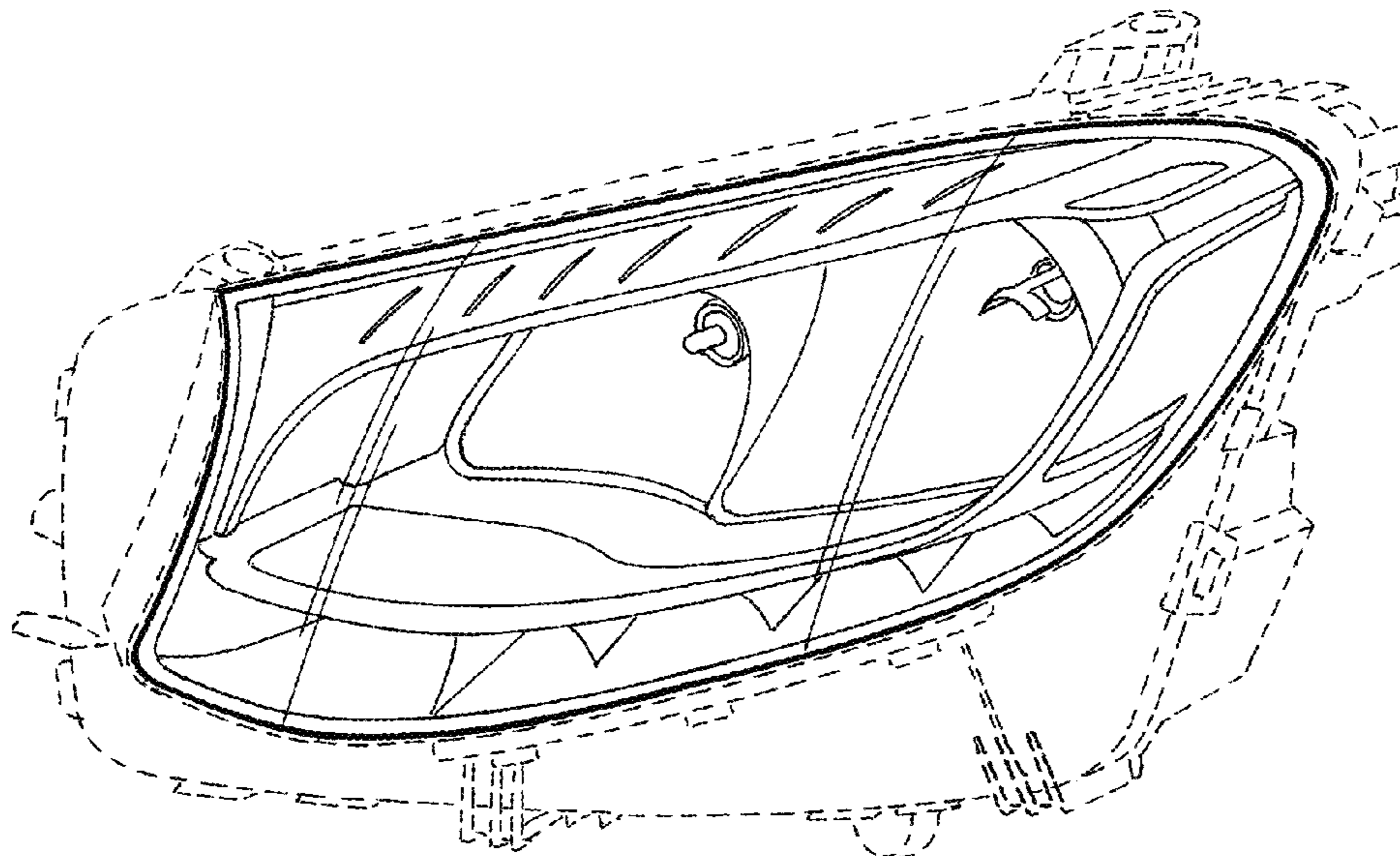

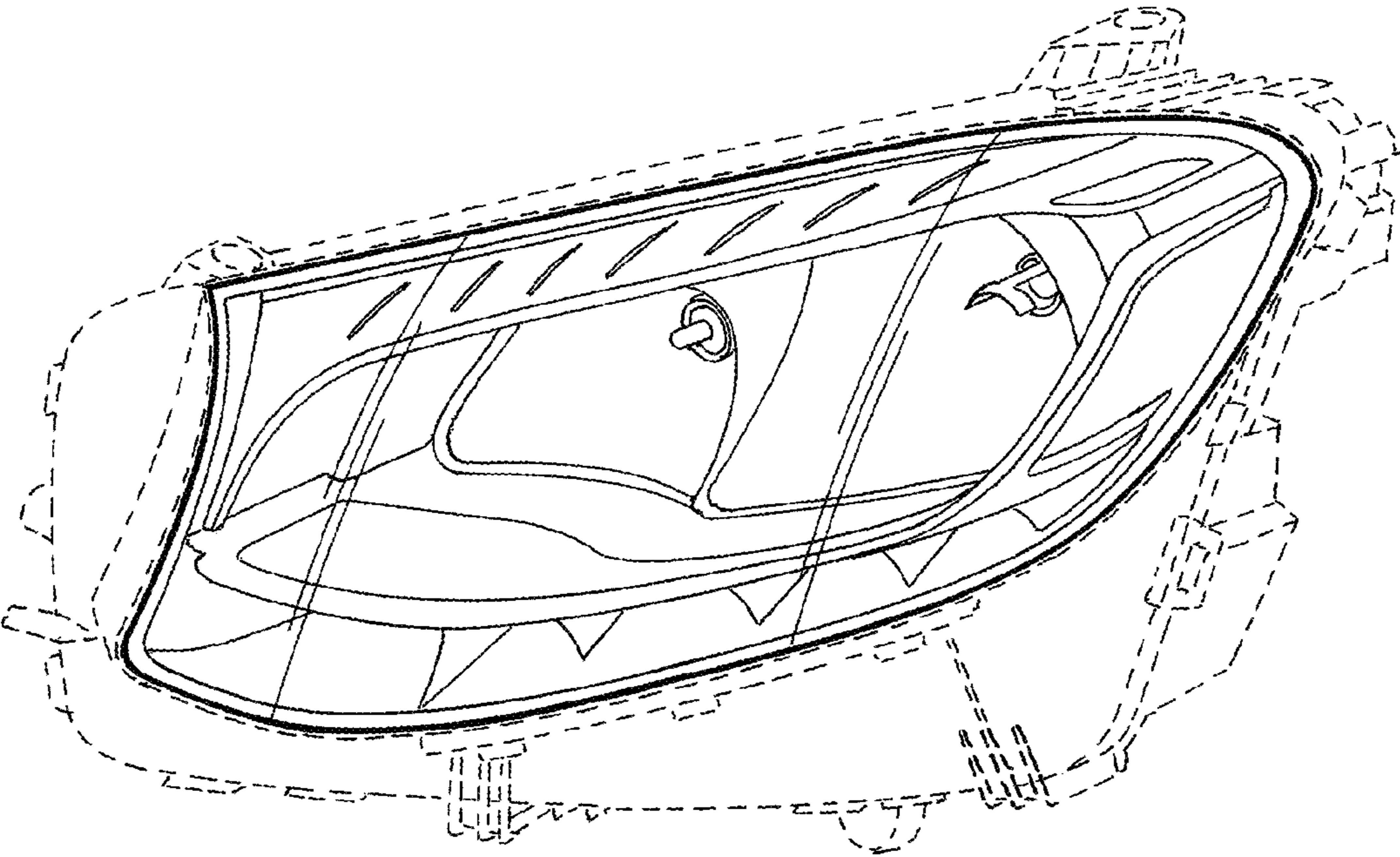

FIG. 1

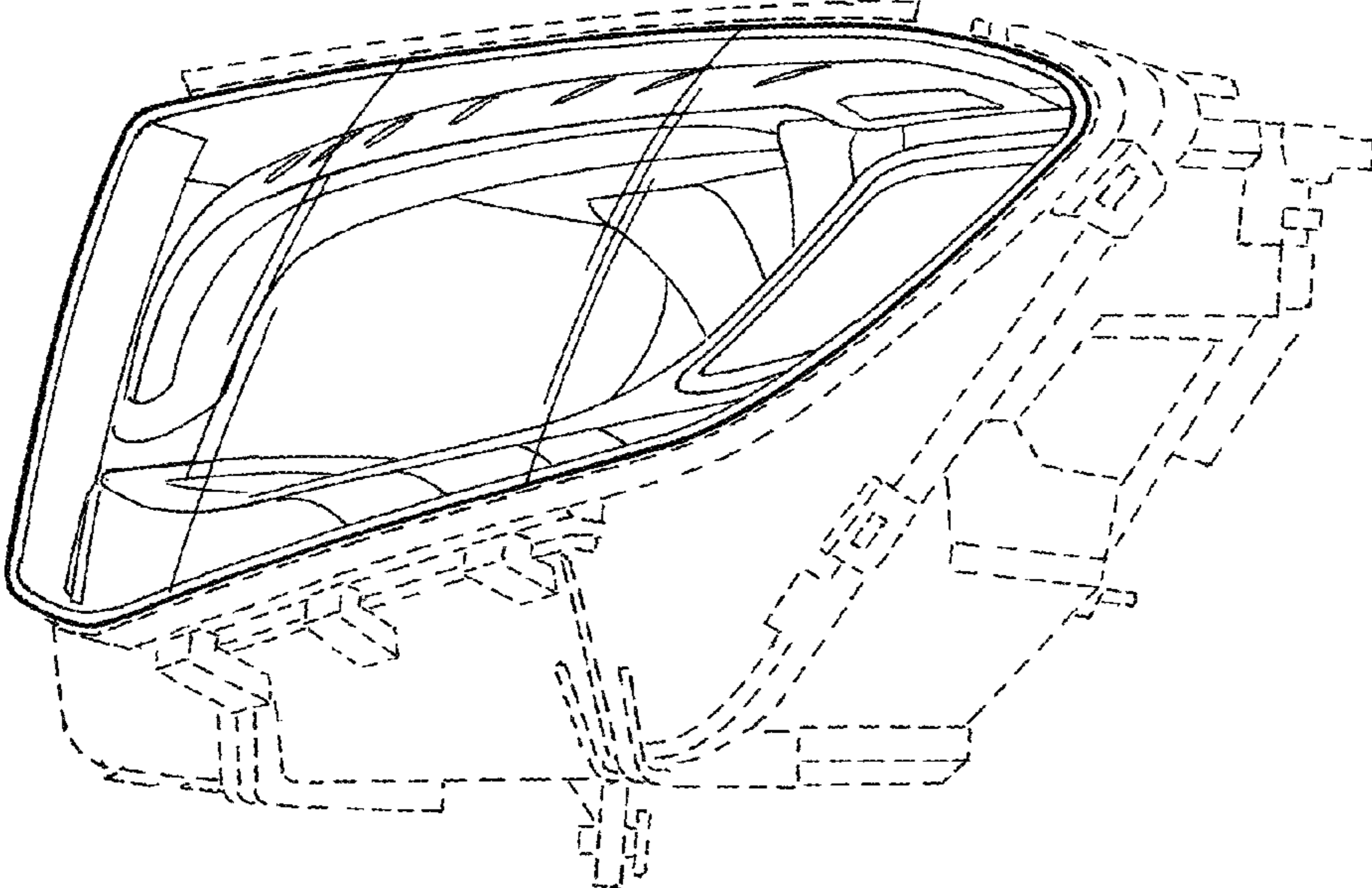

FIG. 2

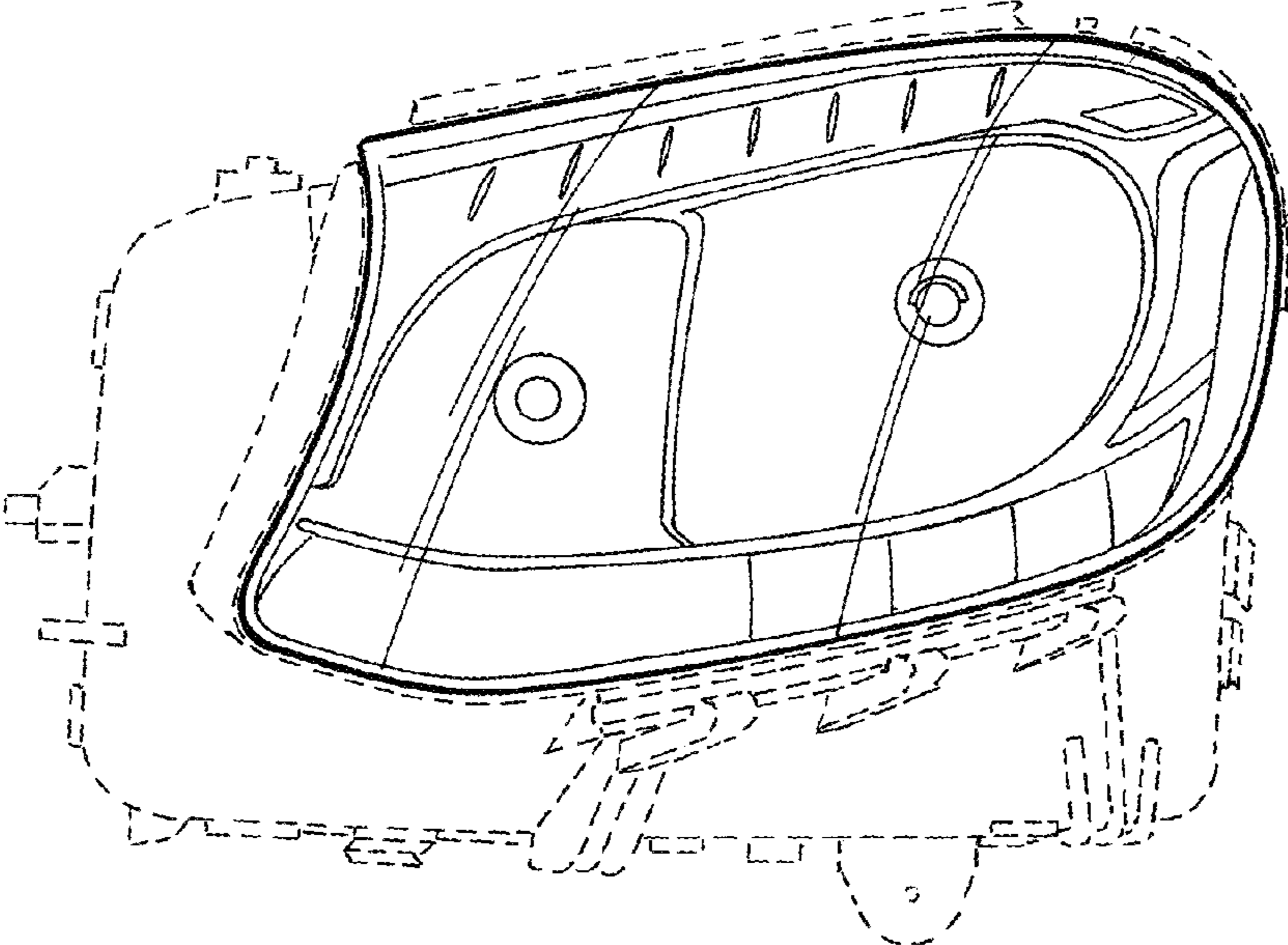

FIG. 3

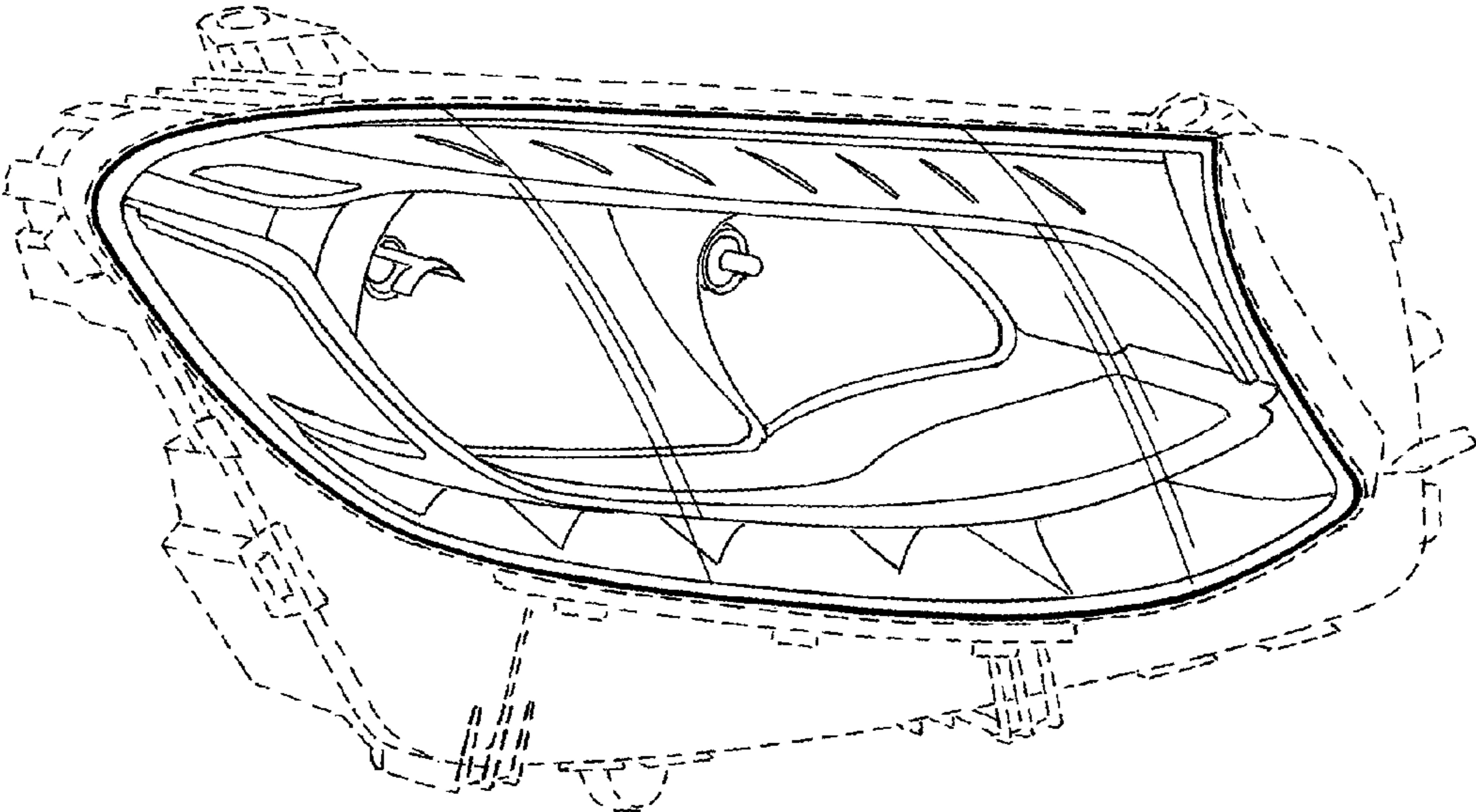

FIG. 4

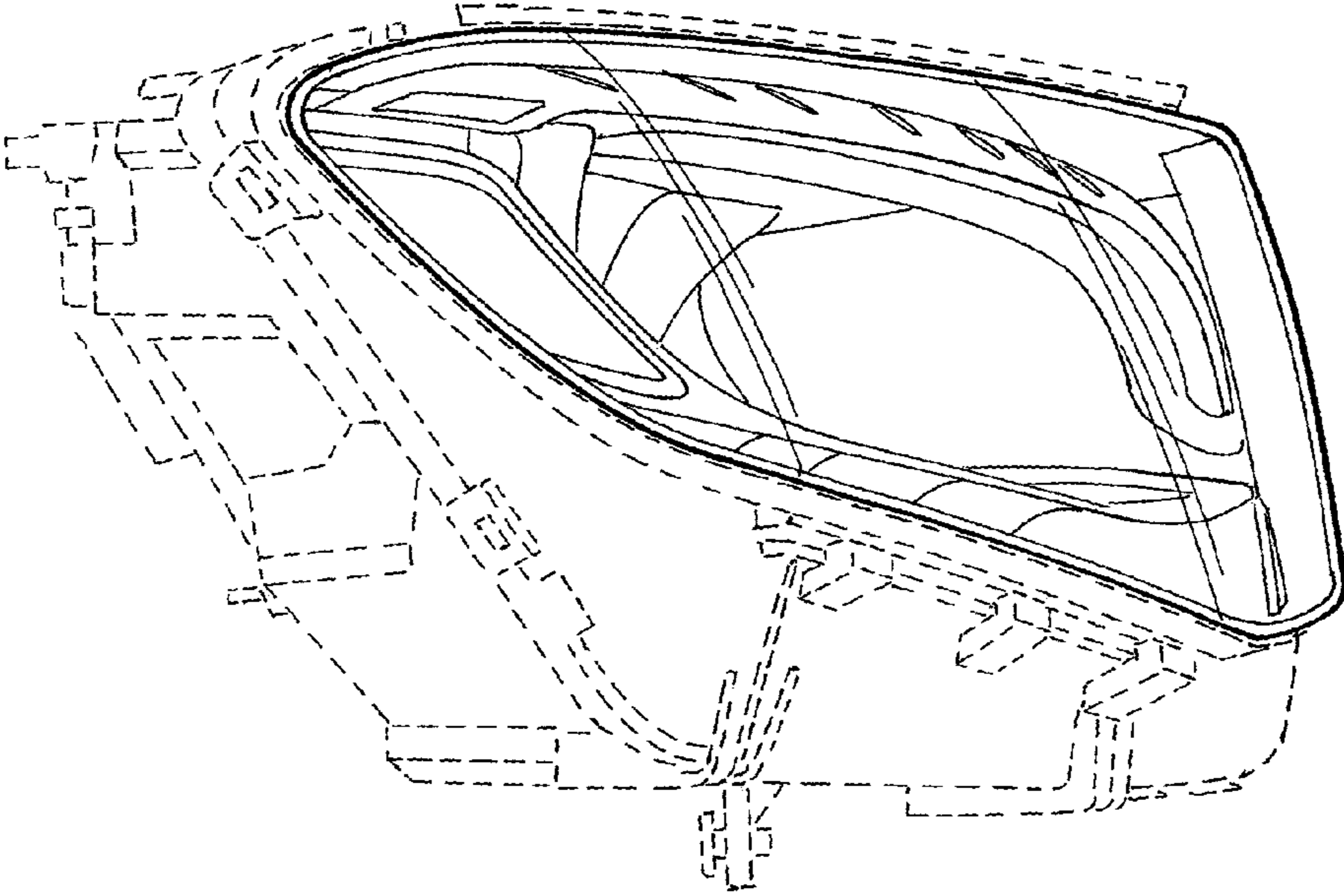

FIG. 5

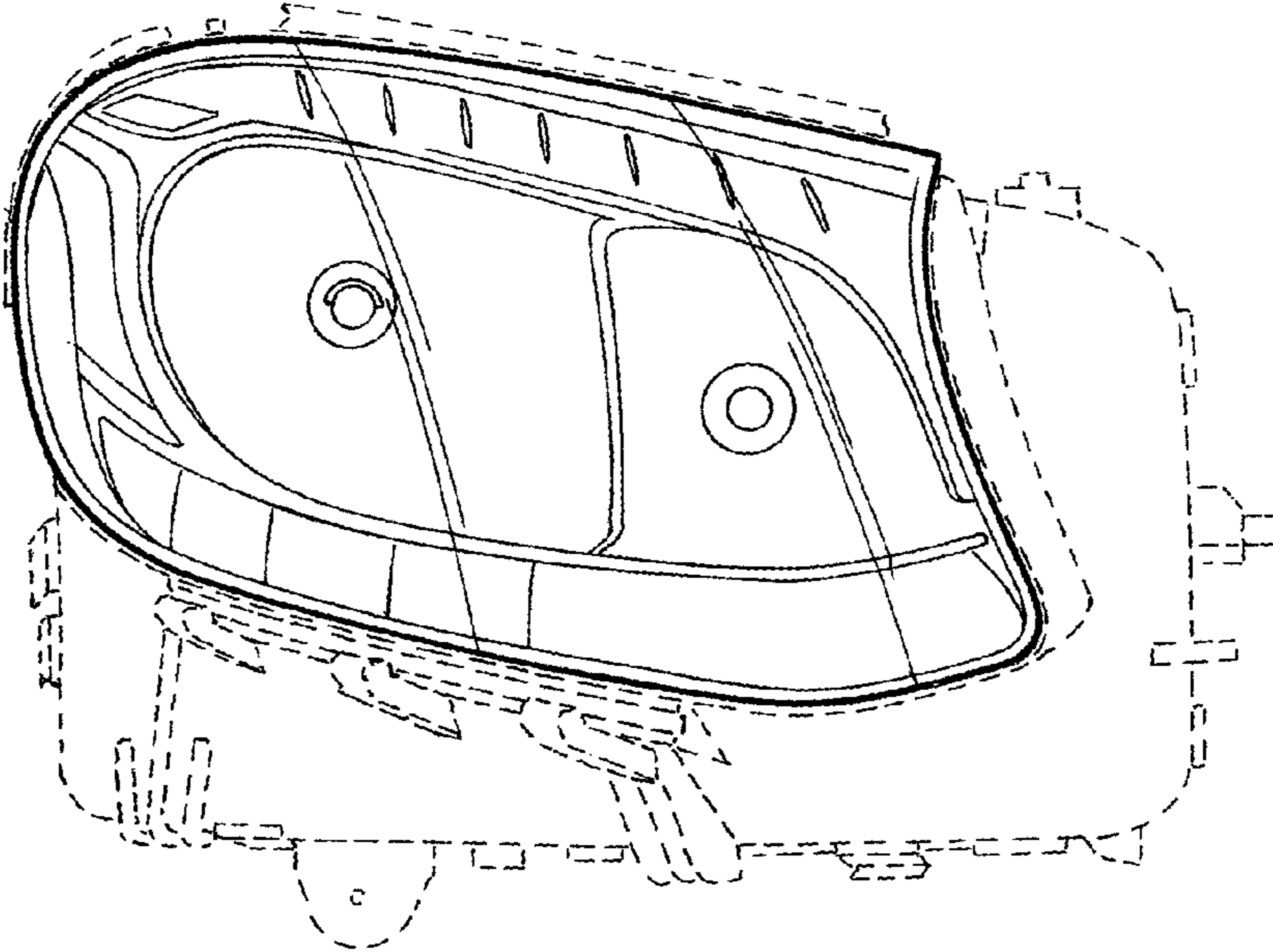

FIG. 6