



US00D755392S

(12) **United States Design Patent**
Hwang et al.

(10) **Patent No.:** **US D755,392 S**
(45) **Date of Patent:** **** May 3, 2016**

(54) **PULSE OXIMETRY SENSOR**

(71) Applicant: **MASIMO CORPORATION**, Irvine, CA (US)

(72) Inventors: **Sujin Hwang**, Irvine, CA (US); **Chad A. DeJong**, Los Angeles, CA (US); **Charles D. O'Neil**, Mission Viejo, CA (US)

(73) Assignee: **MASIMO CORPORATION**, Irvine, CA (US)

(**) Term: **14 Years**

(21) Appl. No.: **29/516,923**

(22) Filed: **Feb. 6, 2015**

(51) **LOC (10) Cl.** **24-02**

(52) **U.S. Cl.**
USPC **D24/165**

(58) **Field of Classification Search**

USPC D24/164, 165
CPC A61B 5/024; A61B 5/02438; A61B 5/02444; A61B 5/145; A61B 5/14503; A61B 5/14507; A61B 5/1451; A61B 5/14514; A61B 5/14517; A61B 5/14521; A61B 5/14525; A61B 5/14528; A61B 5/14532; A61B 5/14535; A61B 5/14539

See application file for complete search history.

(56) **References Cited**

U.S. PATENT DOCUMENTS

4,960,128 A 10/1990 Gordon et al.
4,964,408 A 10/1990 Hink et al.

(Continued)

OTHER PUBLICATIONS

US 8,845,543, 09/2014, Diab et al. (withdrawn).

(Continued)

Primary Examiner — Antoine D Davis

(74) *Attorney, Agent, or Firm* — Knobbe, Martens, Olson & Bear, LLP

(57) **CLAIM**

The ornamental design for a pulse oximetry sensor, as shown and described.

DESCRIPTION

FIG. 1 is a top, front and side perspective view of a first embodiment of a pulse oximetry sensor embodying my new design.

FIG. 2 is a bottom, back and side perspective view thereof.

FIG. 3 is a back and side view thereof.

FIG. 4 is a front and side view thereof.

FIG. 5 is a front view thereof

FIG. 6 is a back view thereof.

FIG. 7 is a first side view thereof.

FIG. 8 is a second side view thereof.

FIG. 9 is a top view thereof.

FIG. 10 is bottom view thereof.

FIG. 11 is a cross-sectional view taken along line 11-11 of FIG. 9.

FIG. 12 is a cross-sectional view taken along line 12-12 of FIG. 9.

FIG. 13 is a cross-sectional view taken along line 13-13 of FIG. 9.

FIG. 14 is a top, front and side perspective view of a second embodiment of a pulse oximetry sensor embodying my new design.

FIG. 15 is a bottom, back and side perspective view thereof.

FIG. 16 is a back and side view thereof.

FIG. 17 is a front and side view thereof.

FIG. 18 is a front view thereof

FIG. 19 is a back view thereof.

FIG. 20 is a first side view thereof.

FIG. 21 is a second side view thereof.

FIG. 22 is a top view thereof; and,

FIG. 23 is bottom view thereof.

Broken lines are used to illustrate features of the pulse oximetry sensor which form no part of the claimed design. The cross-sectional views of FIGS. 11-13 form no part of the claim design but illustrate certain of the contours of the pulse oximetry sensor.

1 Claim, 15 Drawing Sheets

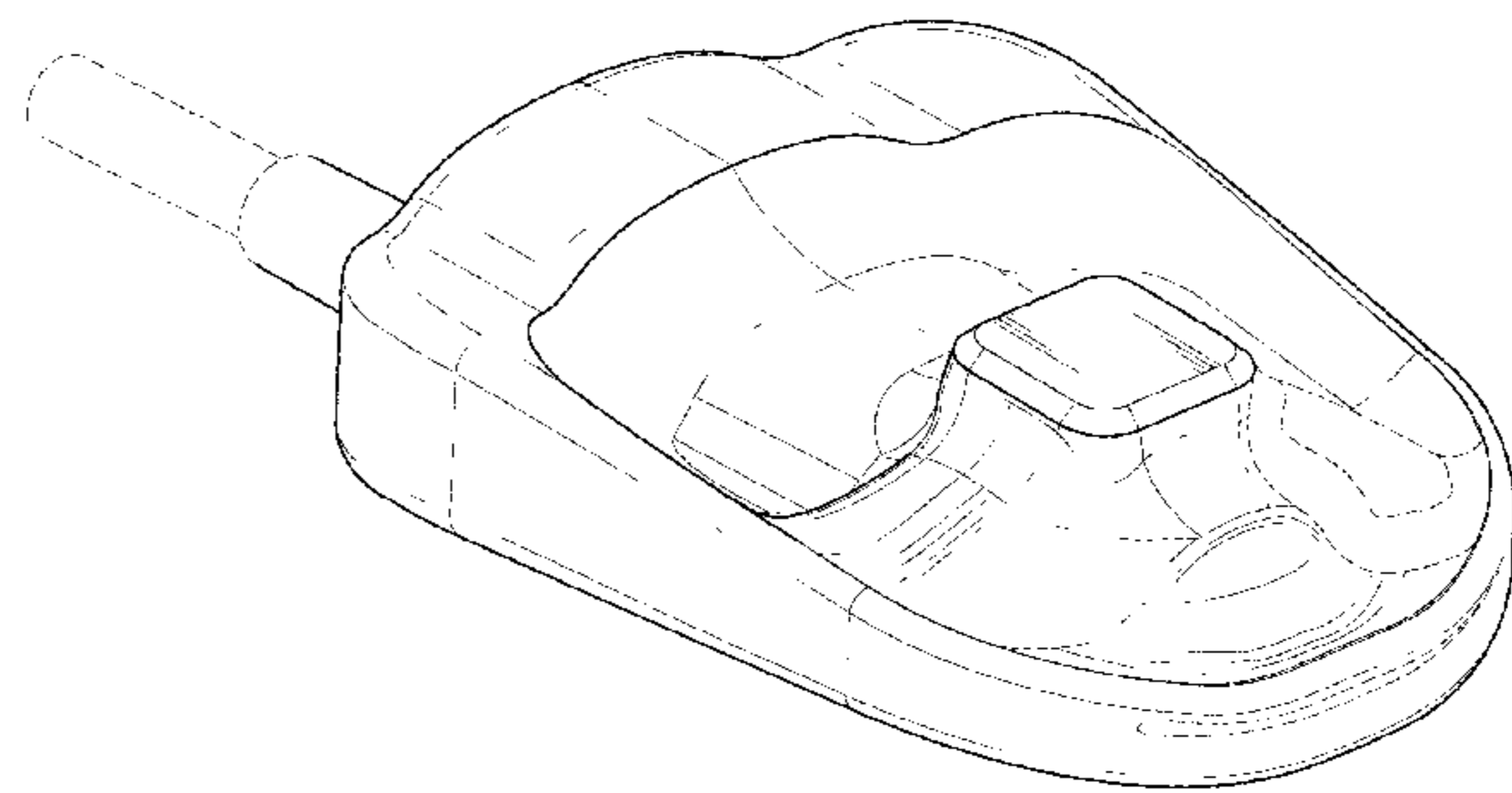
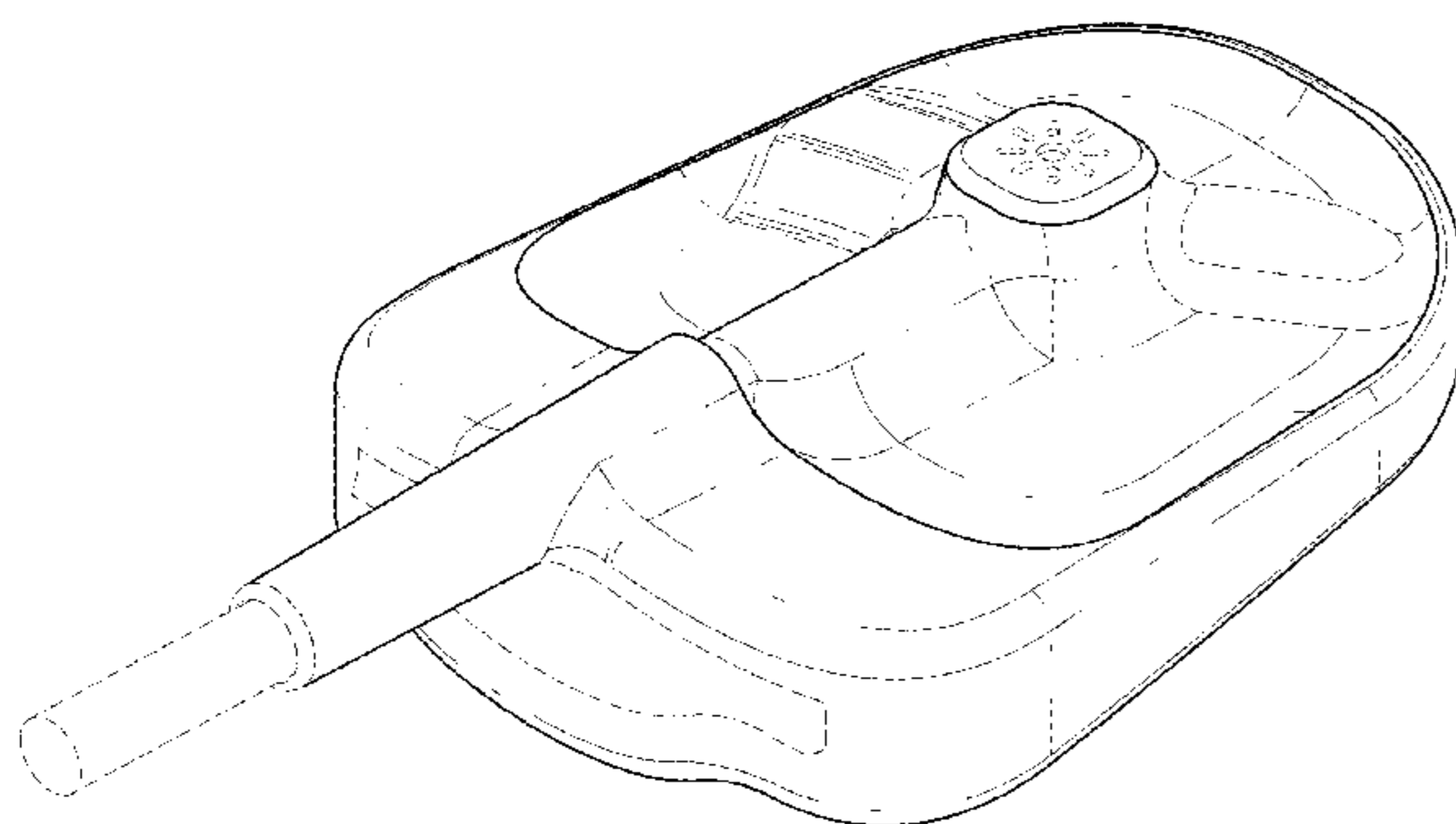

(56)

References Cited

U.S. PATENT DOCUMENTS

5,041,187	A	8/1991	Hink et al.	6,256,523	B1	7/2001	Diab et al.
5,069,213	A	12/1991	Polczynski	6,263,222	B1	7/2001	Diab et al.
5,163,438	A	11/1992	Gordon et al.	6,278,522	B1	8/2001	Lepper, Jr. et al.
5,319,355	A	6/1994	Russek	6,280,213	B1	8/2001	Tobler et al.
5,337,744	A	8/1994	Branigan	6,285,896	B1	9/2001	Tobler et al.
5,341,805	A	8/1994	Stavridi et al.	6,301,493	B1	10/2001	Marro et al.
D353,195	S	12/1994	Savage et al.	6,317,627	B1	11/2001	Ennen et al.
D353,196	S	12/1994	Savage et al.	6,321,100	B1	11/2001	Parker
5,377,676	A	1/1995	Vari et al.	6,325,761	B1	12/2001	Jay
D359,546	S	6/1995	Savage et al.	6,334,065	B1	12/2001	Al-Ali et al.
5,431,170	A	7/1995	Mathews	6,343,224	B1	1/2002	Parker
D361,840	S	8/1995	Savage et al.	6,349,228	B1	2/2002	Kiani et al.
D362,063	S	9/1995	Savage et al.	6,360,114	B1	3/2002	Diab et al.
5,452,717	A	9/1995	Branigan et al.	6,368,283	B1	4/2002	Xu et al.
D363,120	S	10/1995	Savage et al.	6,371,921	B1	4/2002	Caro et al.
5,456,252	A	10/1995	Vari et al.	6,377,829	B1	4/2002	Al-Ali
5,479,934	A	1/1996	Imran	6,388,240	B2	5/2002	Schulz et al.
5,482,036	A	1/1996	Diab et al.	6,397,091	B2	5/2002	Diab et al.
5,490,505	A	2/1996	Diab et al.	6,430,437	B1	8/2002	Marro
5,494,043	A	2/1996	O'Sullivan et al.	6,430,525	B1	8/2002	Weber et al.
5,533,511	A	7/1996	Kaspari et al.	6,463,311	B1	10/2002	Diab
5,534,851	A	7/1996	Russek	6,470,199	B1	10/2002	Kopotic et al.
5,561,275	A	10/1996	Savage et al.	6,501,975	B2	12/2002	Diab et al.
5,562,002	A	10/1996	Lalin	6,505,059	B1	1/2003	Kollias et al.
5,590,649	A	1/1997	Caro et al.	6,515,273	B2	2/2003	Al-Ali
5,602,924	A	2/1997	Durand et al.	6,519,487	B1	2/2003	Parker
5,632,272	A	5/1997	Diab et al.	6,525,386	B1	2/2003	Mills et al.
5,638,816	A	6/1997	Kiani-Azarbayjany et al.	6,526,300	B1	2/2003	Kiani et al.
5,638,818	A	6/1997	Diab et al.	6,541,756	B2	4/2003	Schulz et al.
5,645,440	A	7/1997	Tobler et al.	6,542,764	B1	4/2003	Al-Ali et al.
5,685,299	A	11/1997	Diab et al.	6,580,086	B1	6/2003	Schulz et al.
D393,830	S	4/1998	Tobler et al.	6,584,336	B1	6/2003	Ali et al.
5,743,262	A	4/1998	Lepper, Jr. et al.	6,595,316	B2	7/2003	Cybulski et al.
5,758,644	A	6/1998	Diab et al.	6,597,932	B2	7/2003	Tian et al.
5,760,910	A	6/1998	Lepper, Jr. et al.	6,597,933	B2	7/2003	Kiani et al.
5,769,785	A	6/1998	Diab et al.	6,606,511	B1	8/2003	Ali et al.
5,782,757	A	7/1998	Diab et al.	6,632,181	B2	10/2003	Flaherty et al.
5,785,659	A	7/1998	Caro et al.	6,639,668	B1	10/2003	Trepagnier
5,791,347	A	8/1998	Flaherty et al.	6,640,116	B2	10/2003	Diab
5,810,734	A	9/1998	Caro et al.	6,643,530	B2	11/2003	Diab et al.
5,823,950	A	10/1998	Diab et al.	6,650,917	B2	11/2003	Diab et al.
5,830,131	A	11/1998	Caro et al.	6,654,624	B2	11/2003	Diab et al.
5,833,618	A	11/1998	Caro et al.	6,658,276	B2	12/2003	Kiani et al.
5,860,919	A	1/1999	Kiani-Azarbayjany et al.	6,661,161	B1	12/2003	Lanzo et al.
5,890,929	A	4/1999	Mills et al.	6,671,531	B2	12/2003	Al-Ali et al.
5,904,654	A	5/1999	Wohlmann et al.	6,678,543	B2	1/2004	Diab et al.
5,919,134	A	7/1999	Diab	6,684,090	B2	1/2004	Ali et al.
5,934,925	A	8/1999	Tobler et al.	6,684,091	B2	1/2004	Parker
5,940,182	A	8/1999	Lepper, Jr. et al.	6,697,656	B1	2/2004	Al-Ali
5,995,855	A	11/1999	Kiani et al.	6,697,657	B1	2/2004	Shehada et al.
5,997,343	A	12/1999	Mills et al.	6,697,658	B2	2/2004	Al-Ali
6,002,952	A	12/1999	Diab et al.	RE38,476	E	3/2004	Diab et al.
6,011,986	A	1/2000	Diab et al.	6,699,194	B1	3/2004	Diab et al.
6,027,452	A	2/2000	Flaherty et al.	6,714,804	B2	3/2004	Al-Ali et al.
6,036,642	A	3/2000	Diab et al.	RE38,492	E	4/2004	Diab et al.
6,045,509	A	4/2000	Caro et al.	6,721,582	B2	4/2004	Trepagnier et al.
6,067,462	A	5/2000	Diab et al.	6,721,585	B1	4/2004	Parker
6,081,735	A	6/2000	Diab et al.	6,725,075	B2	4/2004	Al-Ali
6,088,607	A	7/2000	Diab et al.	6,728,560	B2	4/2004	Kollias et al.
6,110,522	A	8/2000	Lepper, Jr. et al.	6,735,459	B2	5/2004	Parker
6,124,597	A	9/2000	Shehada	6,745,060	B2	6/2004	Diab et al.
6,128,521	A	10/2000	Marro et al.	6,760,607	B2	7/2004	Al-Ali
6,129,675	A	10/2000	Jay	6,770,028	B1	8/2004	Ali et al.
6,144,868	A	11/2000	Parker	6,771,994	B2	8/2004	Kiani et al.
6,151,516	A	11/2000	Kiani-Azarbayjany et al.	6,792,300	B1	9/2004	Diab et al.
6,152,754	A	11/2000	Gerhardt et al.	6,813,511	B2	11/2004	Diab et al.
6,157,850	A	12/2000	Diab et al.	6,816,741	B2	11/2004	Diab
6,165,005	A	12/2000	Mills et al.	6,822,564	B2	11/2004	Al-Ali
6,184,521	B1	2/2001	Coffin, IV et al.	6,826,419	B2	11/2004	Diab et al.
6,206,830	B1	3/2001	Diab et al.	6,830,711	B2	12/2004	Mills et al.
6,229,856	B1	5/2001	Diab et al.	6,850,787	B2	2/2005	Weber et al.
6,232,609	B1	5/2001	Snyder et al.	6,850,788	B2	2/2005	Al-Ali
6,236,872	B1	5/2001	Diab et al.	6,852,083	B2	2/2005	Caro et al.
6,241,683	B1	6/2001	Macklem et al.	6,861,639	B2	3/2005	Al-Ali
6,253,097	B1	6/2001	Aronow et al.	6,898,452	B2	5/2005	Al-Ali et al.
				6,920,345	B2	7/2005	Al-Ali et al.
				6,931,268	B1	8/2005	Kiani-Azarbayjany et al.
				6,934,570	B2	8/2005	Kiani et al.
				6,939,305	B2	9/2005	Flaherty et al.

(56)

References Cited

U.S. PATENT DOCUMENTS

6,943,348 B1	9/2005	Coffin, IV	7,489,958 B2	2/2009	Diab et al.
6,950,687 B2	9/2005	Al-Ali	7,496,391 B2	2/2009	Diab et al.
6,961,598 B2	11/2005	Diab	7,496,393 B2	2/2009	Diab et al.
6,970,792 B1	11/2005	Diab	D587,657 S	3/2009	Al-Ali et al.
6,979,812 B2	12/2005	Al-Ali	7,499,741 B2	3/2009	Diab et al.
6,985,764 B2	1/2006	Mason et al.	7,499,835 B2	3/2009	Weber et al.
6,993,371 B2	1/2006	Kiani et al.	7,500,950 B2	3/2009	Al-Ali et al.
6,996,427 B2	2/2006	Ali et al.	7,509,154 B2	3/2009	Diab et al.
6,999,904 B2	2/2006	Weber et al.	7,509,494 B2	3/2009	Al-Ali
7,003,338 B2	2/2006	Weber et al.	7,510,849 B2	3/2009	Schurman et al.
7,003,339 B2	2/2006	Diab et al.	7,526,328 B2	4/2009	Diab et al.
7,015,451 B2	3/2006	Dalke et al.	7,530,942 B1	5/2009	Diab
7,024,233 B2	4/2006	Ali et al.	7,530,949 B2	5/2009	Al Ali et al.
7,027,849 B2	4/2006	Al-Ali	7,530,955 B2	5/2009	Diab et al.
7,030,749 B2	4/2006	Al-Ali	7,563,110 B2	7/2009	Al-Ali et al.
7,039,449 B2	5/2006	Al-Ali	7,596,397 B2 *	9/2009	Ortner A61B 5/026 600/340
7,041,060 B2	5/2006	Flaherty et al.	7,596,398 B2	9/2009	Al-Ali et al.
7,044,918 B2	5/2006	Diab	7,618,375 B2	11/2009	Flaherty
7,067,893 B2	6/2006	Mills et al.	D606,659 S	12/2009	Kiani et al.
7,096,052 B2	8/2006	Mason et al.	7,647,083 B2	1/2010	Al-Ali et al.
7,096,054 B2	8/2006	Abdul-Hafiz et al.	D609,193 S	2/2010	Al-Ali et al.
7,132,641 B2	11/2006	Schulz et al.	D614,305 S	4/2010	Al-Ali et al.
7,142,901 B2	11/2006	Kiani et al.	RE41,317 E	5/2010	Parker
7,149,561 B2	12/2006	Diab	7,729,733 B2	6/2010	Al-Ali et al.
7,186,966 B2	3/2007	Al-Ali	7,734,320 B2	6/2010	Al-Ali
7,190,261 B2	3/2007	Al-Ali	7,761,127 B2	7/2010	Al-Ali et al.
7,215,984 B2	5/2007	Diab	7,761,128 B2	7/2010	Al-Ali et al.
7,215,986 B2	5/2007	Diab	7,764,982 B2	7/2010	Dalke et al.
7,221,971 B2	5/2007	Diab	D621,516 S	8/2010	Kiani et al.
7,225,006 B2	5/2007	Al-Ali et al.	7,791,155 B2	9/2010	Diab
7,225,007 B2	5/2007	Al-Ali	7,801,581 B2	9/2010	Diab
RE39,672 E	6/2007	Shehada et al.	7,822,452 B2	10/2010	Schurman et al.
7,239,905 B2	7/2007	Kiani-Azarbayjany et al.	RE41,912 E	11/2010	Parker
7,245,953 B1	7/2007	Parker	7,844,313 B2	11/2010	Kiani et al.
7,254,429 B2	8/2007	Schurman et al.	7,844,314 B2	11/2010	Al-Ali
7,254,431 B2	8/2007	Al-Ali	7,844,315 B2	11/2010	Al-Ali
7,254,433 B2	8/2007	Diab et al.	7,865,222 B2	1/2011	Weber et al.
7,254,434 B2	8/2007	Schulz et al.	7,873,497 B2	1/2011	Weber et al.
7,272,425 B2	9/2007	Al-Ali	7,880,606 B2	2/2011	Al-Ali
7,274,955 B2	9/2007	Kiani et al.	7,880,626 B2	2/2011	Al-Ali et al.
D554,263 S	10/2007	Al-Ali	7,891,355 B2	2/2011	Al-Ali et al.
7,280,858 B2	10/2007	Al-Ali et al.	7,894,868 B2	2/2011	Al-Ali et al.
7,289,835 B2	10/2007	Mansfield et al.	7,899,507 B2	3/2011	Al-Ali et al.
7,292,883 B2	11/2007	De Felice et al.	7,899,518 B2	3/2011	Trepagnier et al.
7,295,866 B2	11/2007	Al-Ali	7,904,132 B2	3/2011	Weber et al.
7,328,053 B1	2/2008	Diab et al.	7,909,772 B2	3/2011	Popov et al.
7,332,784 B2	2/2008	Mills et al.	7,910,875 B2	3/2011	Al-Ali
7,340,287 B2	3/2008	Mason et al.	7,919,713 B2	4/2011	Al-Ali et al.
7,341,559 B2	3/2008	Schulz et al.	7,937,128 B2	5/2011	Al-Ali
7,343,186 B2	3/2008	Lamego et al.	7,937,129 B2	5/2011	Mason et al.
D566,282 S	4/2008	Al-Ali et al.	7,937,130 B2	5/2011	Diab et al.
7,355,512 B1	4/2008	Al-Ali	7,941,199 B2	5/2011	Kiani
7,356,365 B2	4/2008	Schurman	7,951,086 B2	5/2011	Flaherty et al.
7,359,742 B2 *	4/2008	Maser A61B 5/14552 600/340	7,957,780 B2	6/2011	Lamego et al.
7,371,981 B2	5/2008	Abdul-Hafiz	7,962,188 B2	6/2011	Kiani et al.
7,373,193 B2	5/2008	Al-Ali et al.	7,962,190 B1	6/2011	Diab et al.
7,373,194 B2	5/2008	Weber et al.	7,976,472 B2	7/2011	Kiani
7,376,453 B1	5/2008	Diab et al.	D643,929 S *	8/2011	DelloStritto D24/165
7,377,794 B2	5/2008	Al-Ali et al.	7,988,637 B2	8/2011	Diab
7,377,899 B2	5/2008	Weber et al.	7,990,382 B2	8/2011	Kiani
7,383,070 B2	6/2008	Diab et al.	7,991,446 B2	8/2011	Ali et al.
7,415,297 B2	8/2008	Al-Ali et al.	8,000,761 B2	8/2011	Al-Ali
7,428,432 B2	9/2008	Ali et al.	8,008,088 B2	8/2011	Bellott et al.
7,438,683 B2	10/2008	Al-Ali et al.	RE42,753 E	9/2011	Kiani-Azarbayjany et al.
7,440,787 B2	10/2008	Diab	8,019,400 B2	9/2011	Diab et al.
7,454,240 B2	11/2008	Diab et al.	8,028,701 B2	10/2011	Al-Ali et al.
7,460,897 B1 *	12/2008	Flessland A61B 5/0059 600/344	8,029,765 B2	10/2011	Bellott et al.
7,467,002 B2	12/2008	Weber et al.	8,036,727 B2	10/2011	Schurman et al.
7,469,157 B2	12/2008	Diab et al.	8,036,728 B2	10/2011	Diab et al.
7,471,969 B2	12/2008	Diab et al.	8,046,040 B2	10/2011	Ali et al.
7,471,971 B2	12/2008	Diab et al.	8,046,041 B2	10/2011	Diab et al.
7,483,729 B2	1/2009	Al-Ali et al.	8,046,042 B2	10/2011	Diab et al.
7,483,730 B2	1/2009	Diab et al.	8,048,040 B2	11/2011	Kiani
			8,050,728 B2	11/2011	Al-Ali et al.
			RE43,169 E	2/2012	Parker
			8,118,620 B2	2/2012	Al-Ali et al.
			8,126,528 B2	2/2012	Diab et al.
			8,128,572 B2	3/2012	Diab et al.

(56)

References Cited

U.S. PATENT DOCUMENTS

8,130,105 B2	3/2012	Al-Ali et al.	8,571,617 B2	10/2013	Reichgott et al.
8,145,287 B2	3/2012	Diab et al.	8,571,618 B1	10/2013	Lamego et al.
8,150,487 B2	4/2012	Diab et al.	8,571,619 B2	10/2013	Al-Ali et al.
8,175,672 B2	5/2012	Parker	8,577,431 B2	11/2013	Lamego et al.
8,180,420 B2	5/2012	Diab et al.	8,581,732 B2	11/2013	Al-Ali et al.
8,182,443 B1	5/2012	Kiani	8,584,345 B2	11/2013	Al-Ali et al.
8,185,180 B2	5/2012	Diab et al.	8,588,880 B2	11/2013	Abdul-Hafiz et al.
8,190,223 B2	5/2012	Al-Ali et al.	8,600,467 B2	12/2013	Al-Ali et al.
8,190,227 B2	5/2012	Diab et al.	8,606,342 B2	12/2013	Diab
8,203,438 B2	6/2012	Kiani et al.	8,626,255 B2	1/2014	Al-Ali et al.
8,203,704 B2	6/2012	Merritt et al.	8,630,691 B2	1/2014	Lamego et al.
8,204,566 B2	6/2012	Schurman et al.	8,634,889 B2	1/2014	Al-Ali et al.
8,219,172 B2	7/2012	Schurman et al.	8,641,631 B2	2/2014	Sierra et al.
8,224,411 B2	7/2012	Al-Ali et al.	8,652,060 B2	2/2014	Al-Ali
8,228,181 B2	7/2012	Al-Ali	8,663,107 B2	3/2014	Kiani
8,229,533 B2	7/2012	Diab et al.	8,666,468 B1	3/2014	Al-Ali
8,233,955 B2	7/2012	Al-Ali et al.	8,667,967 B2	3/2014	Al-Ali et al.
8,244,325 B2	8/2012	Al-Ali et al.	8,670,811 B2	3/2014	O'Reilly
8,255,026 B1	8/2012	Al-Ali	8,670,814 B2	3/2014	Diab et al.
8,255,027 B2	8/2012	Al-Ali et al.	8,676,286 B2	3/2014	Weber et al.
8,255,028 B2	8/2012	Al-Ali et al.	8,682,407 B2	3/2014	Al-Ali
8,260,577 B2	9/2012	Weber et al.	RE44,823 E	4/2014	Parker
8,265,723 B1	9/2012	McHale et al.	RE44,875 E	4/2014	Kiani et al.
8,274,360 B2	9/2012	Sampath et al.	8,690,799 B2	4/2014	Telfort et al.
8,301,217 B2	10/2012	Al-Ali et al.	8,700,112 B2	4/2014	Kiani
8,306,596 B2	11/2012	Schurman et al.	8,702,627 B2	4/2014	Telfort et al.
8,310,336 B2	11/2012	Muhsin et al.	8,706,179 B2	4/2014	Parker
8,315,683 B2	11/2012	Al-Ali et al.	8,712,494 B1	4/2014	MacNeish, III et al.
RE43,860 E	12/2012	Parker	8,715,206 B2	5/2014	Telfort et al.
8,337,403 B2	12/2012	Al-Ali et al.	8,718,735 B2	5/2014	Lamego et al.
8,346,330 B2	1/2013	Lamego	8,718,737 B2	5/2014	Diab et al.
8,353,842 B2	1/2013	Al-Ali et al.	8,718,738 B2	5/2014	Blank et al.
8,355,766 B2	1/2013	MacNeish, III et al.	8,720,249 B2	5/2014	Al-Ali
8,359,080 B2	1/2013	Diab et al.	8,721,541 B2	5/2014	Al-Ali et al.
8,364,223 B2	1/2013	Al-Ali et al.	8,721,542 B2	5/2014	Al-Ali et al.
8,364,226 B2	1/2013	Diab et al.	8,723,677 B1	5/2014	Kiani
8,374,665 B2	2/2013	Lamego	8,740,792 B1	6/2014	Kiani et al.
8,385,995 B2	2/2013	Al-Ali et al.	8,754,776 B2	6/2014	Poeze et al.
8,385,996 B2	2/2013	Smith et al.	8,755,535 B2	6/2014	Telfort et al.
8,388,353 B2	3/2013	Kiani et al.	8,755,856 B2	6/2014	Diab et al.
8,399,822 B2	3/2013	Al-Ali	8,755,872 B1	6/2014	Marinow
8,401,602 B2	3/2013	Kiani	8,761,850 B2	6/2014	Lamego
8,405,608 B2	3/2013	Al-Ali et al.	8,764,671 B2	7/2014	Kiani
8,414,499 B2	4/2013	Al-Ali et al.	8,768,423 B2	7/2014	Shakespeare et al.
8,418,524 B2	4/2013	Al-Ali	8,771,204 B2	7/2014	Telfort et al.
8,423,106 B2	4/2013	Lamego et al.	8,777,634 B2	7/2014	Kiani et al.
8,428,967 B2	4/2013	Olsen et al.	8,781,543 B2	7/2014	Diab et al.
8,430,817 B1	4/2013	Al-Ali et al.	8,781,544 B2	7/2014	Al-Ali et al.
8,437,825 B2	5/2013	Dalvi et al.	8,781,549 B2	7/2014	Al-Ali et al.
8,455,290 B2	6/2013	Siskavich	8,788,003 B2	7/2014	Schurman et al.
8,457,703 B2	6/2013	Al-Ali	8,790,268 B2	7/2014	Al-Ali
8,457,707 B2	6/2013	Kiani	8,801,613 B2	8/2014	Al-Ali et al.
8,463,349 B2	6/2013	Diab et al.	8,821,397 B2	9/2014	Al-Ali et al.
8,466,286 B2	6/2013	Bellott et al.	8,821,415 B2	9/2014	Al-Ali et al.
8,471,713 B2	6/2013	Poeze et al.	8,830,449 B1	9/2014	Lamego et al.
8,473,020 B2	6/2013	Kiani et al.	8,831,700 B2	9/2014	Schurman et al.
8,483,787 B2	7/2013	Al-Ali et al.	8,840,549 B2	9/2014	Al-Ali et al.
8,489,364 B2	7/2013	Weber et al.	8,847,740 B2	9/2014	Kiani et al.
8,498,684 B2	7/2013	Weber et al.	8,849,365 B2	9/2014	Smith et al.
8,504,128 B2	8/2013	Blank et al.	8,852,094 B2	10/2014	Al-Ali et al.
8,509,867 B2	8/2013	Workman et al.	8,852,994 B2	10/2014	Wojtczuk et al.
8,515,509 B2	8/2013	Bruinsma et al.	8,868,147 B2	10/2014	Stippick et al.
8,523,781 B2	9/2013	Al-Ali	8,868,150 B2	10/2014	Al-Ali et al.
8,529,301 B2	9/2013	Al-Ali et al.	8,870,792 B2	10/2014	Al-Ali et al.
8,532,727 B2	9/2013	Ali et al.	8,886,271 B2	11/2014	Kiani et al.
8,532,728 B2	9/2013	Diab et al.	8,888,539 B2	11/2014	Al-Ali et al.
D692,145 S	10/2013	Al-Ali et al.	8,888,708 B2	11/2014	Diab et al.
8,547,209 B2	10/2013	Kiani et al.	8,892,180 B2	11/2014	Weber et al.
8,548,548 B2	10/2013	Al-Ali	8,897,847 B2	11/2014	Al-Ali
8,548,549 B2	10/2013	Schurman et al.	8,909,310 B2	12/2014	Lamego et al.
8,548,550 B2	10/2013	Al-Ali et al.	8,911,377 B2	12/2014	Al-Ali
8,560,032 B2	10/2013	Al-Ali et al.	8,912,909 B2	12/2014	Al-Ali et al.
8,560,034 B1	10/2013	Diab et al.	8,920,317 B2	12/2014	Al-Ali et al.
8,570,167 B2	10/2013	Al-Ali	8,921,699 B2	12/2014	Al-Ali et al.
8,570,503 B2	10/2013	Vo et al.	8,922,382 B2	12/2014	Al-Ali et al.
			8,929,964 B2	1/2015	Al-Ali et al.
			8,942,777 B2	1/2015	Diab et al.
			8,948,834 B2	2/2015	Diab et al.
			8,948,835 B2	2/2015	Diab

(56)

References Cited

U.S. PATENT DOCUMENTS

- | | | | |
|--------------|----|---------|--------------------|
| 8,965,471 | B2 | 2/2015 | Lamego |
| 8,983,564 | B2 | 3/2015 | Al-Ali |
| 8,989,831 | B2 | 3/2015 | Al-Ali et al. |
| 8,996,085 | B2 | 3/2015 | Kiani et al. |
| 8,998,809 | B2 | 4/2015 | Kiani |
| 2009/0247984 | A1 | 10/2009 | Lamego et al. |
| 2009/0275844 | A1 | 11/2009 | Al-Ali |
| 2009/0299157 | A1 | 12/2009 | Telfort et al. |
| 2010/0004518 | A1 | 1/2010 | Vo et al. |
| 2010/0030040 | A1 | 2/2010 | Poeze et al. |
| 2010/0261979 | A1 | 10/2010 | Kiani |
| 2011/0001605 | A1 | 1/2011 | Kiani et al. |
| 2011/0082711 | A1 | 4/2011 | Poeze et al. |
| 2011/0105854 | A1 | 5/2011 | Kiani et al. |
| 2011/0208015 | A1 | 8/2011 | Welch et al. |
| 2011/0209915 | A1 | 9/2011 | Telfort et al. |
| 2011/0213212 | A1 | 9/2011 | Al-Ali |
| 2011/0230733 | A1 | 9/2011 | Al-Ali |
| 2011/0237911 | A1 | 9/2011 | Lamego et al. |
| 2012/0059267 | A1 | 3/2012 | Lamego et al. |
| 2012/0116175 | A1 | 5/2012 | Al-Ali et al. |
| 2012/0179006 | A1 | 7/2012 | Jansen et al. |
| 2012/0209082 | A1 | 8/2012 | Al-Ali |
| 2012/0209084 | A1 | 8/2012 | Olsen et al. |
| 2012/0227739 | A1 | 9/2012 | Kiani |
| 2012/0265039 | A1 | 10/2012 | Kiani |
| 2012/0283524 | A1 | 11/2012 | Kiani et al. |
| 2012/0286955 | A1 | 11/2012 | Welch et al. |
| 2012/0296178 | A1 | 11/2012 | Lamego et al. |
| 2012/0319816 | A1 | 12/2012 | Al-Ali |
| 2012/0330112 | A1 | 12/2012 | Lamego et al. |
| 2013/0023775 | A1 | 1/2013 | Lamego et al. |
| 2013/0041591 | A1 | 2/2013 | Lamego |
| 2013/0045685 | A1 | 2/2013 | Kiani |
| 2013/0046204 | A1 | 2/2013 | Lamego et al. |
| 2013/0060108 | A1 | 3/2013 | Schurman et al. |
| 2013/0060147 | A1 | 3/2013 | Welch et al. |
| 2013/0096405 | A1 | 4/2013 | Garfio |
| 2013/0096936 | A1 | 4/2013 | Sampath et al. |
| 2013/0109935 | A1 | 5/2013 | Al-Ali et al. |
| 2013/0162433 | A1 | 6/2013 | Muhsin et al. |
| 2013/0190581 | A1 | 7/2013 | Al-Ali et al. |
| 2013/0197328 | A1 | 8/2013 | Diab et al. |
| 2013/0211214 | A1 | 8/2013 | Olsen |
| 2013/0243021 | A1 | 9/2013 | Siskavich |
| 2013/0253334 | A1 | 9/2013 | Al-Ali et al. |
| 2013/0274571 | A1 | 10/2013 | Diab et al. |
| 2013/0296672 | A1 | 11/2013 | O'Neil et al. |
| 2013/0317370 | A1 | 11/2013 | Dalvi et al. |
| 2013/0324808 | A1 | 12/2013 | Al-Ali et al. |
| 2013/0331670 | A1 | 12/2013 | Kiani |
| 2013/0338461 | A1 | 12/2013 | Lamego et al. |
| 2014/0012100 | A1 | 1/2014 | Al-Ali et al. |
| 2014/0025306 | A1 | 1/2014 | Weber et al. |
| 2014/0034353 | A1 | 2/2014 | Al-Ali et al. |
| 2014/0051952 | A1 | 2/2014 | Reichgott et al. |
| 2014/0051953 | A1 | 2/2014 | Lamego et al. |
| 2014/0051954 | A1 | 2/2014 | Al-Ali et al. |
| 2014/0058230 | A1 | 2/2014 | Abdul-Hafiz et al. |
| 2014/0066783 | A1 | 3/2014 | Kiani et al. |
| 2014/0077956 | A1 | 3/2014 | Sampath et al. |
| 2014/0081100 | A1 | 3/2014 | Muhsin et al. |
| 2014/0081175 | A1 | 3/2014 | Telfort |
| 2014/0094667 | A1 | 4/2014 | Schurman et al. |
| 2014/0100434 | A1 | 4/2014 | Diab et al. |
| 2014/0114199 | A1 | 4/2014 | Lamego et al. |
| 2014/0120564 | A1 | 5/2014 | Workman et al. |
| 2014/0121482 | A1 | 5/2014 | Merritt et al. |
| 2014/0121483 | A1 | 5/2014 | Kiani |
| 2014/0125495 | A1 | 5/2014 | Al-Ali |
| 2014/0127137 | A1 | 5/2014 | Bellott et al. |
| 2014/0128696 | A1 | 5/2014 | Al-Ali |
| 2014/0128699 | A1 | 5/2014 | Al-Ali et al. |
| 2014/0129702 | A1 | 5/2014 | Lamego et al. |
| 2014/0135588 | A1 | 5/2014 | Al-Ali et al. |
| 2014/0142401 | A1 | 5/2014 | Al-Ali et al. |
| 2014/0142402 | A1 | 5/2014 | Al-Ali et al. |
| 2014/0163344 | A1 | 6/2014 | Al-Ali |
| 2014/0163402 | A1 | 6/2014 | Lamego et al. |
| 2014/0166076 | A1 | 6/2014 | Kiani et al. |
| 2014/0171763 | A1 | 6/2014 | Diab |
| 2014/0180038 | A1 | 6/2014 | Kiani |
| 2014/0180154 | A1 | 6/2014 | Sierra et al. |
| 2014/0194709 | A1 | 7/2014 | Al-Ali et al. |
| 2014/0194711 | A1 | 7/2014 | Al-Ali |
| 2014/0194766 | A1 | 7/2014 | Al-Ali et al. |
| 2014/0200420 | A1 | 7/2014 | Al-Ali |
| 2014/0200422 | A1 | 7/2014 | Weber et al. |
| 2014/0206963 | A1 | 7/2014 | Al-Ali |
| 2014/0213864 | A1 | 7/2014 | Abdul-Hafiz et al. |
| 2014/0243627 | A1 | 8/2014 | Diab et al. |
| 2014/0266790 | A1 | 9/2014 | Al-Ali et al. |
| 2014/0275808 | A1 | 9/2014 | Poeze et al. |
| 2014/0275835 | A1 | 9/2014 | Lamego et al. |
| 2014/0275871 | A1 | 9/2014 | Lamego et al. |
| 2014/0275872 | A1 | 9/2014 | Merritt et al. |
| 2014/0275881 | A1 | 9/2014 | Lamego et al. |
| 2014/0288400 | A1 | 9/2014 | Diab et al. |
| 2014/0296664 | A1 | 10/2014 | Bruinsma et al. |
| 2014/0303520 | A1 | 10/2014 | Telfort et al. |
| 2014/0309506 | A1 | 10/2014 | Lamego et al. |
| 2014/0309559 | A1 | 10/2014 | Telfort et al. |
| 2014/0316228 | A1 | 10/2014 | Blank et al. |
| 2014/0323825 | A1 | 10/2014 | Al-Ali et al. |
| 2014/0330092 | A1 | 11/2014 | Al-Ali et al. |
| 2014/0330098 | A1 | 11/2014 | Merritt et al. |
| 2014/0330099 | A1 | 11/2014 | Al-Ali et al. |
| 2014/0333440 | A1 | 11/2014 | Kiani |
| 2014/0336481 | A1 | 11/2014 | Shakespeare et al. |
| 2014/0343436 | A1 | 11/2014 | Kiani |
| 2015/0018650 | A1 | 1/2015 | Al-Ali et al. |

OTHER PUBLICATIONS

Philips Electronics N.V. "Reusable sensors that last" brochure. Sep. 2008.

* cited by examiner

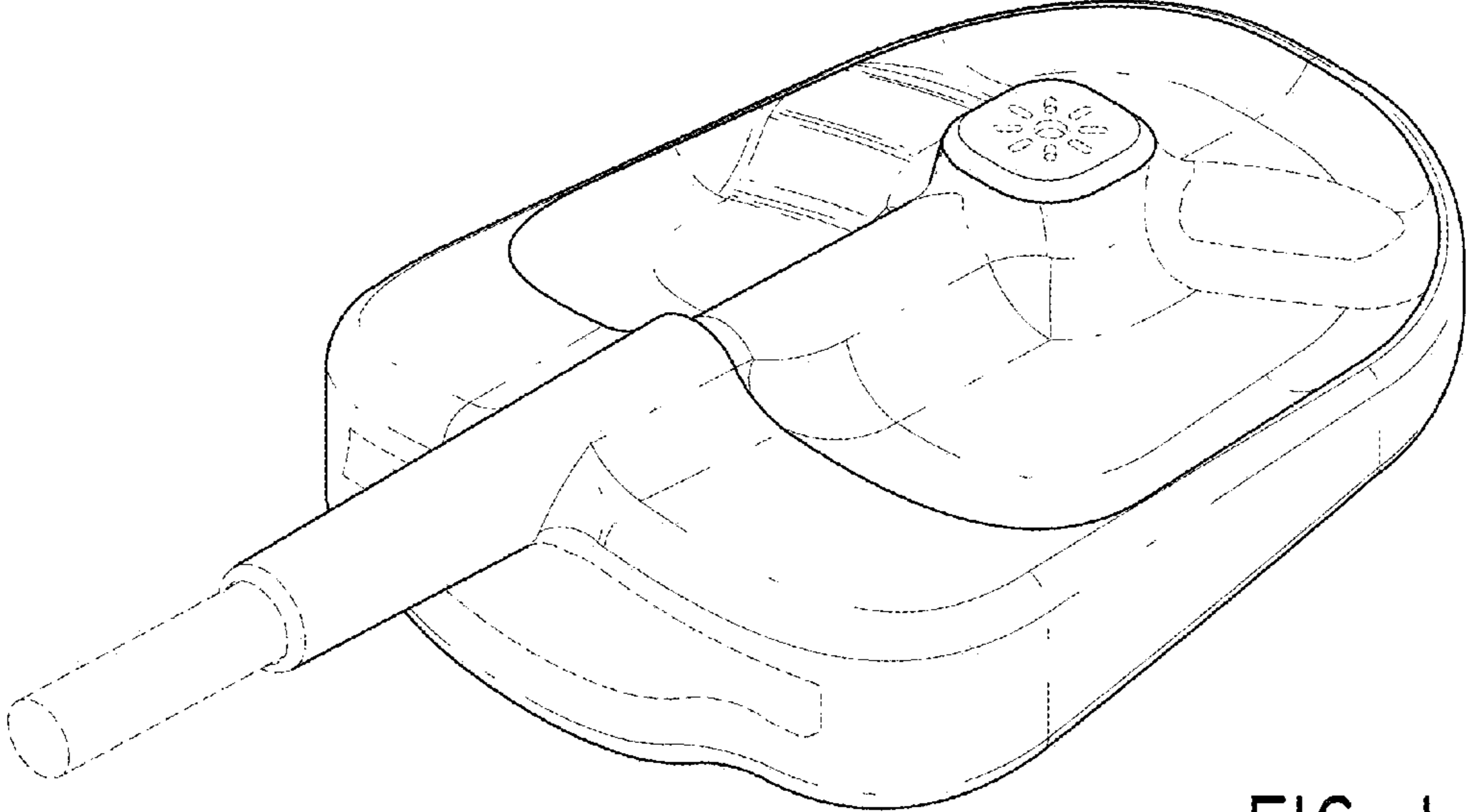

FIG. 1

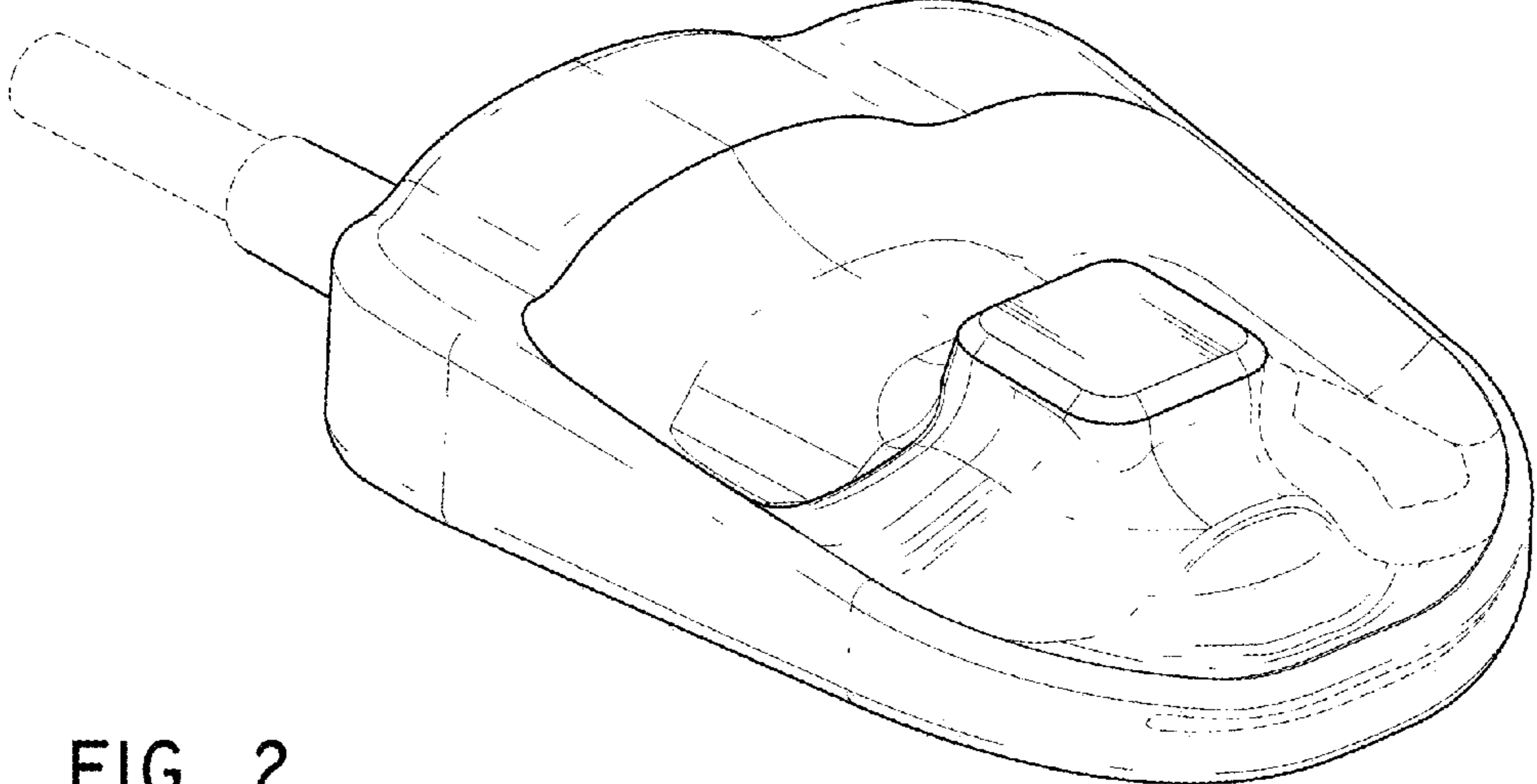

FIG. 2

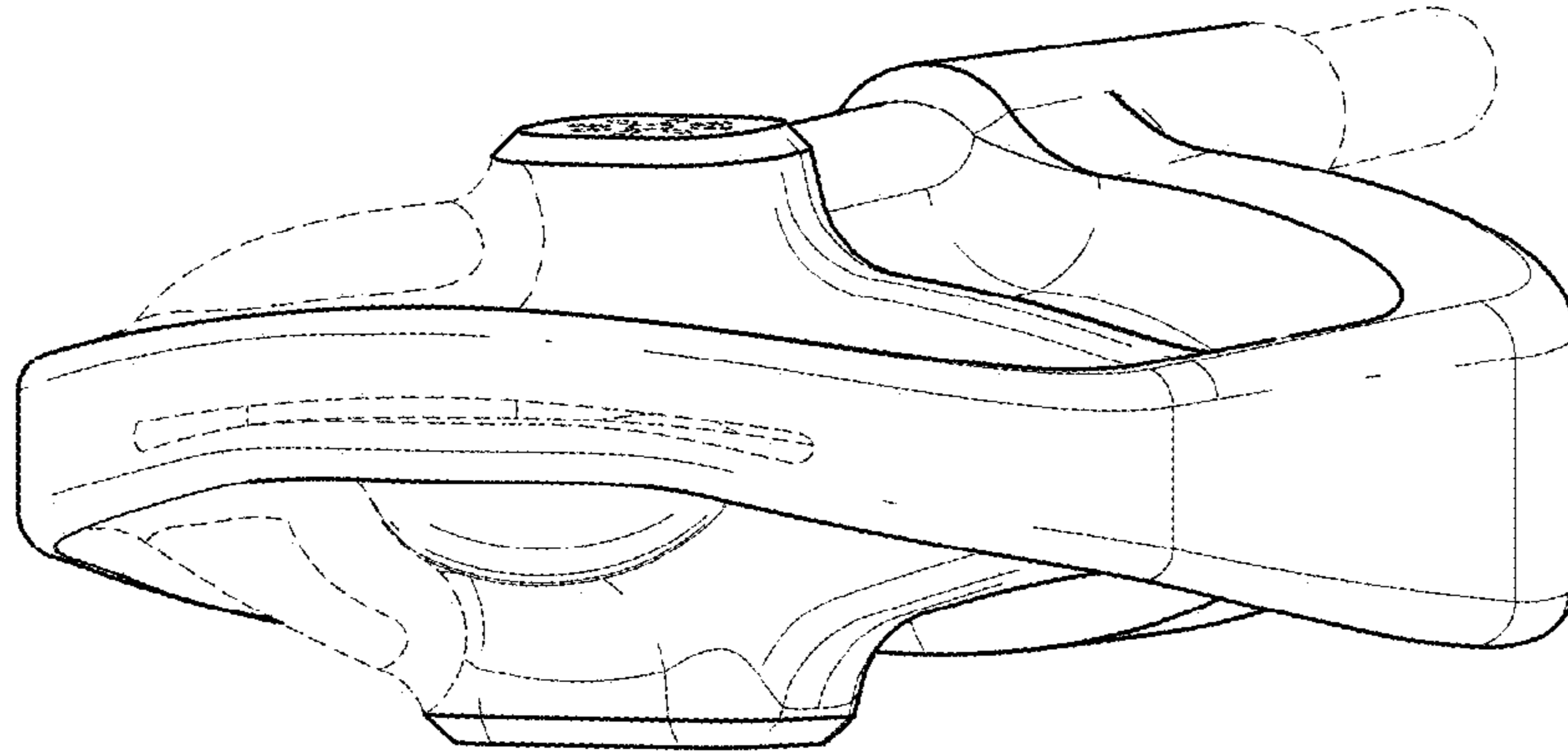

FIG. 3

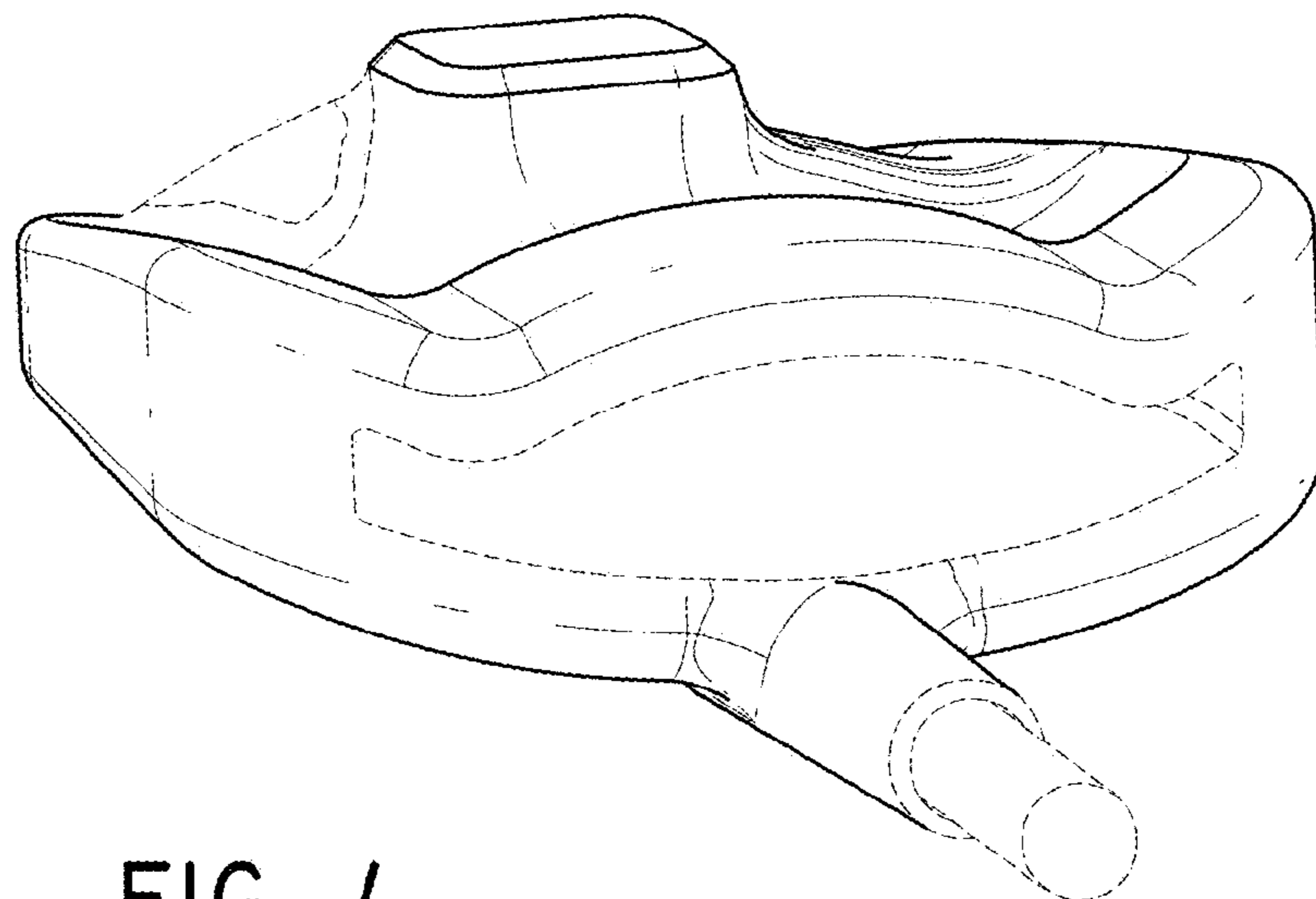

FIG. 4

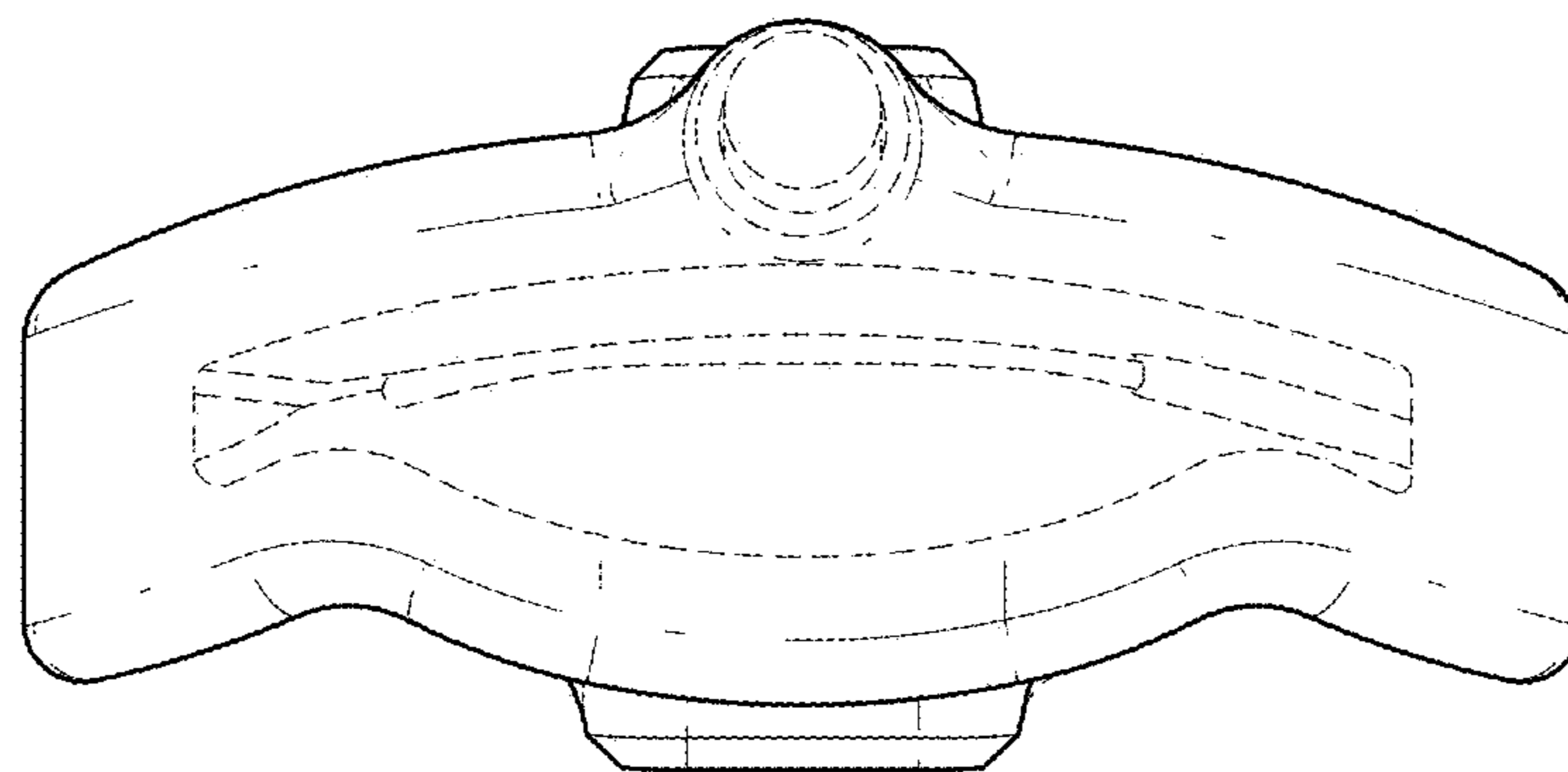

FIG. 5

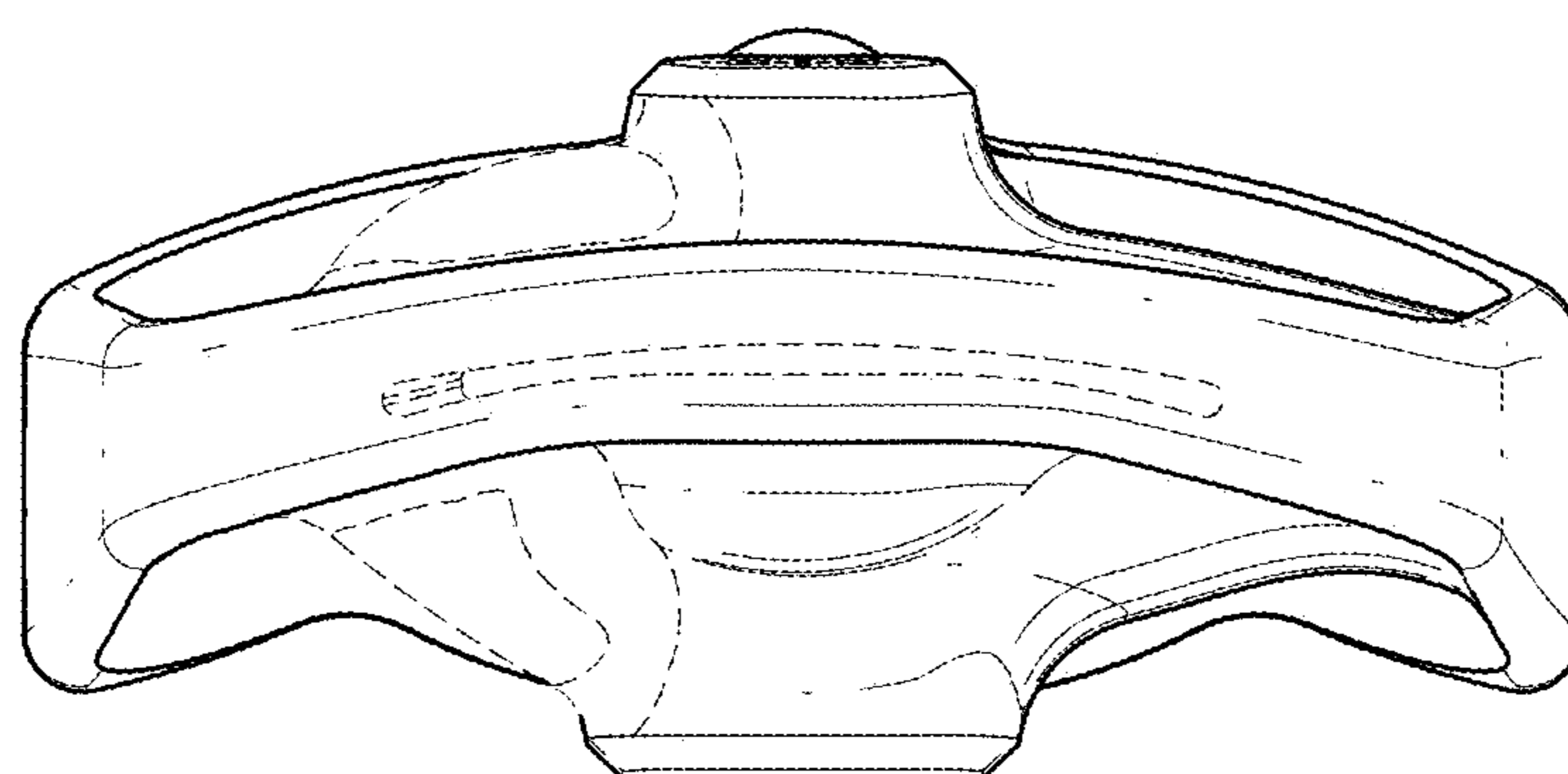

FIG. 6

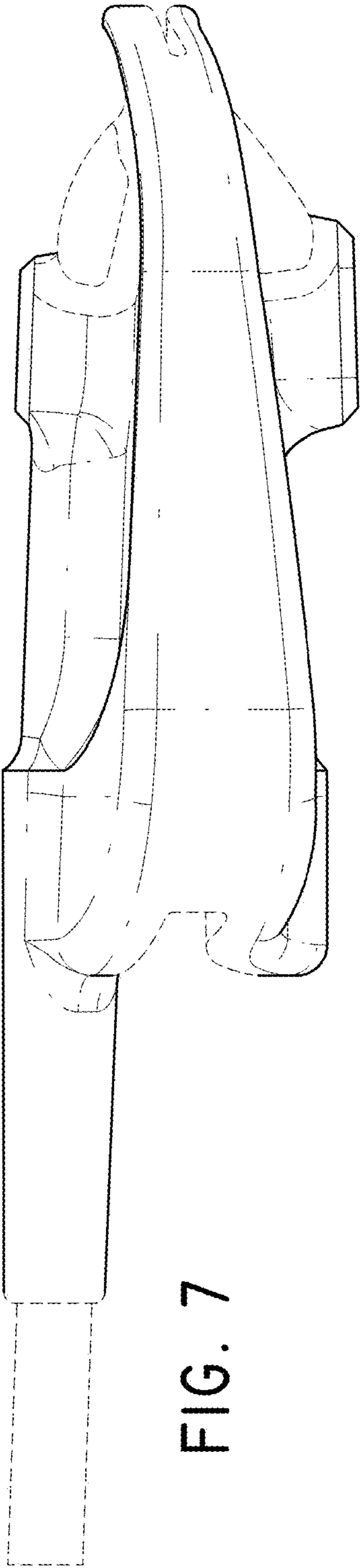

FIG. 7

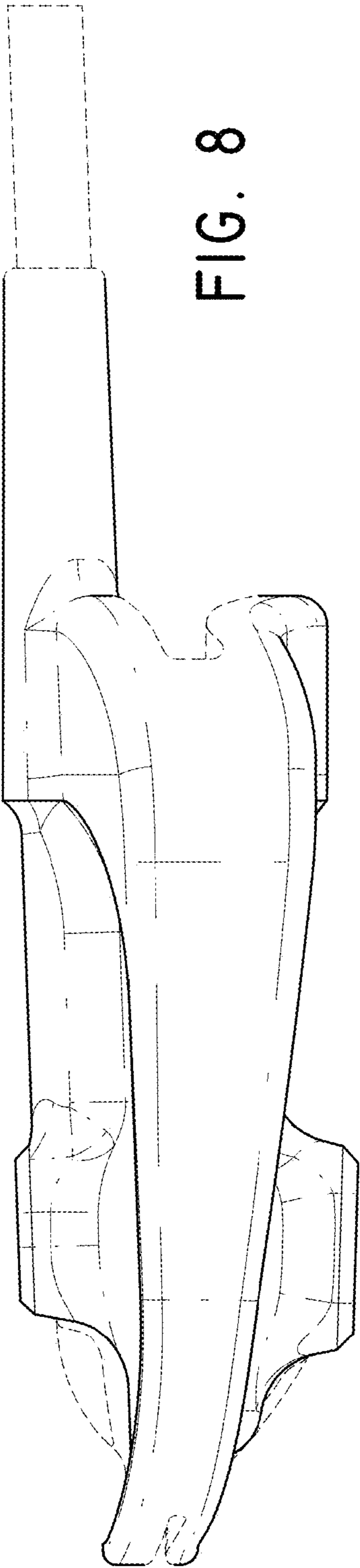

FIG. 8

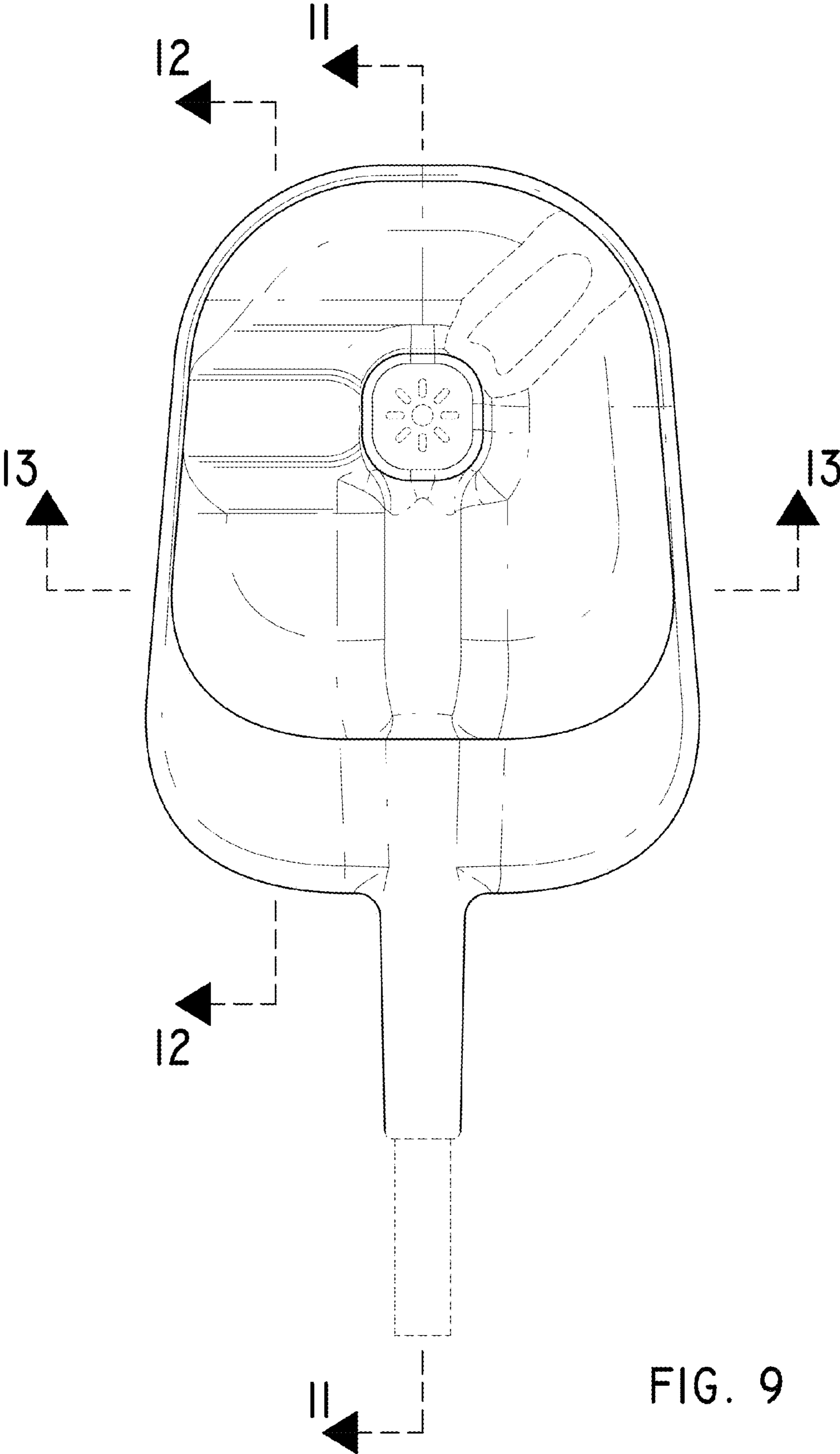

FIG. 9

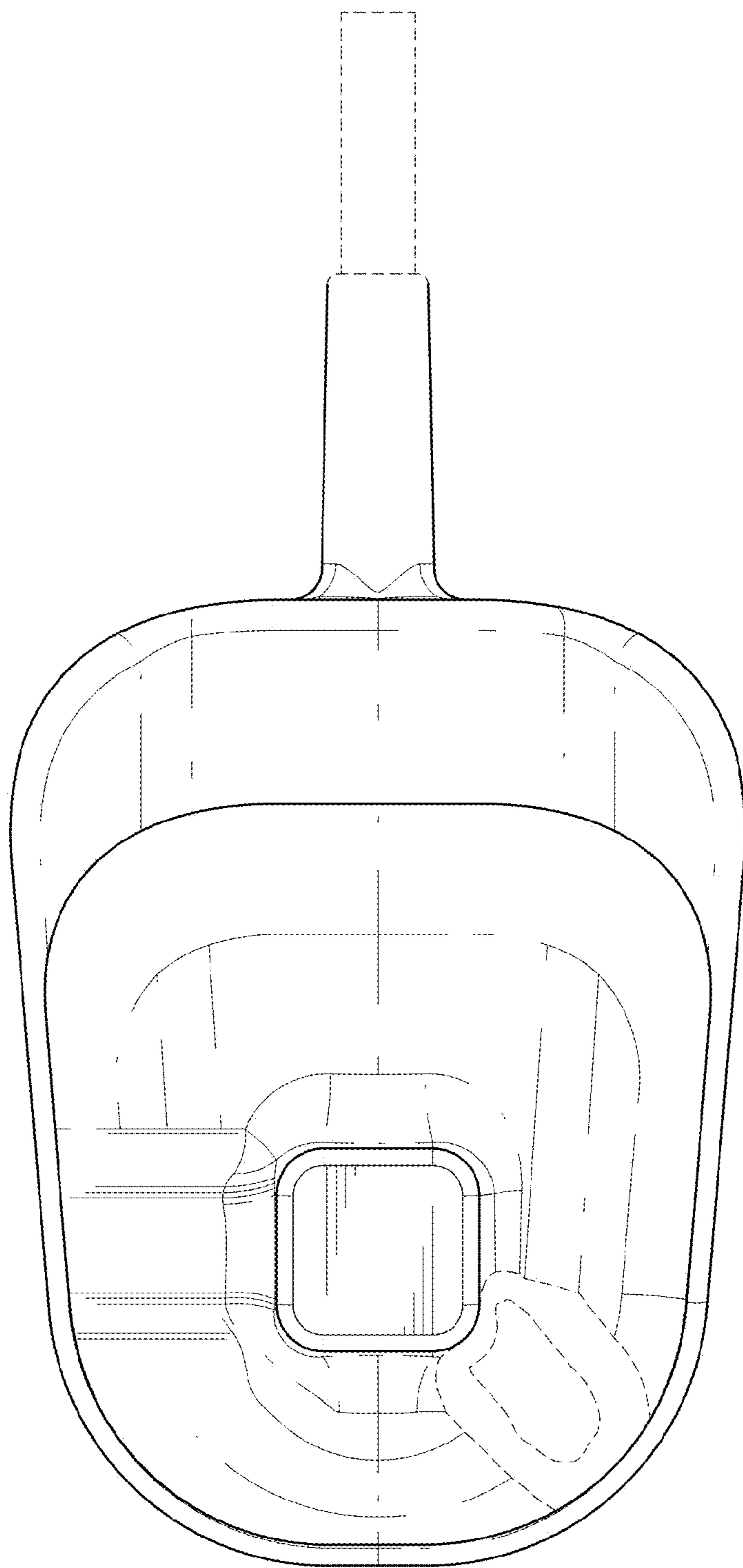

FIG. 10

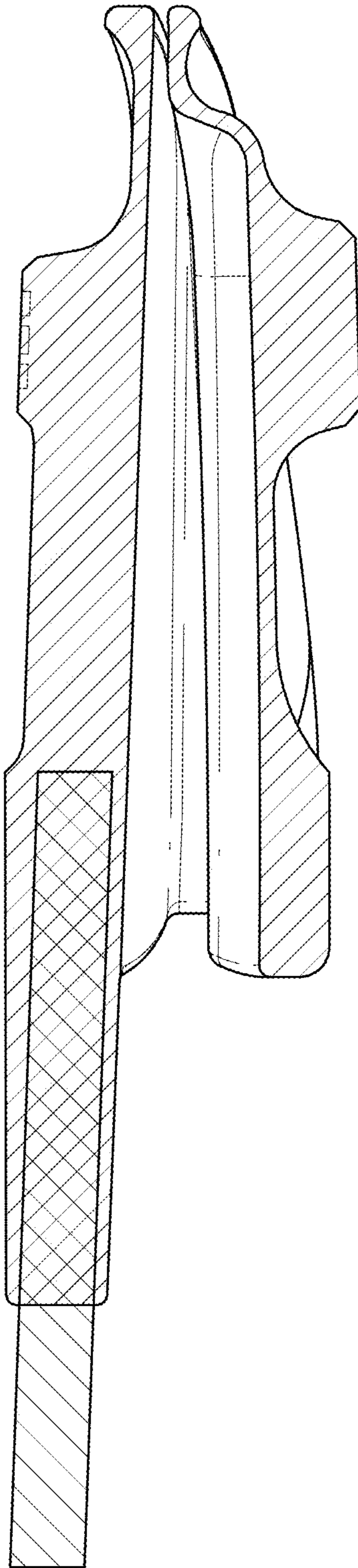

FIG. II

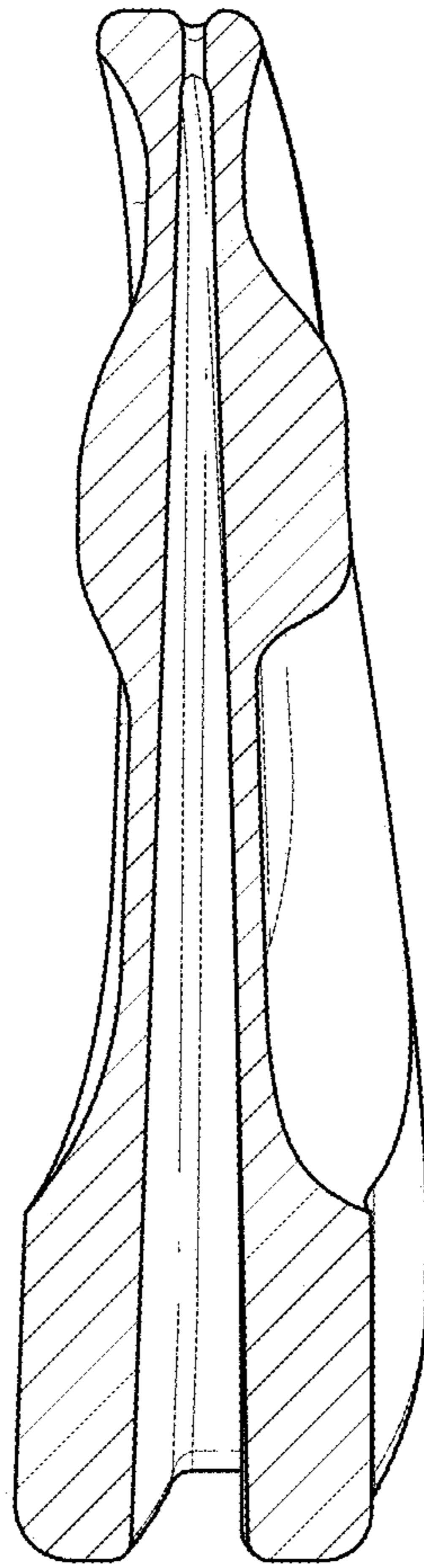

FIG. 12

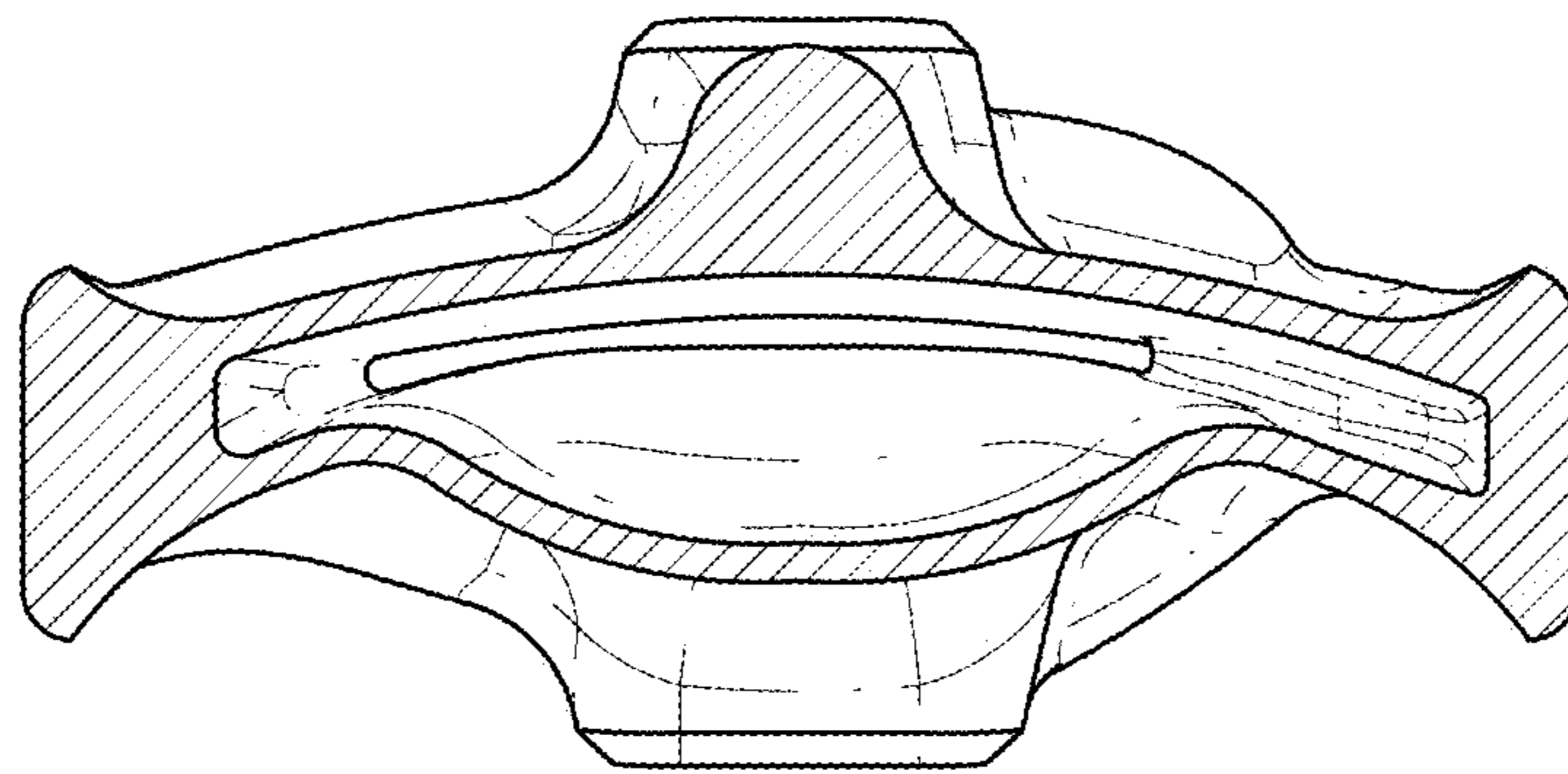

FIG. 13

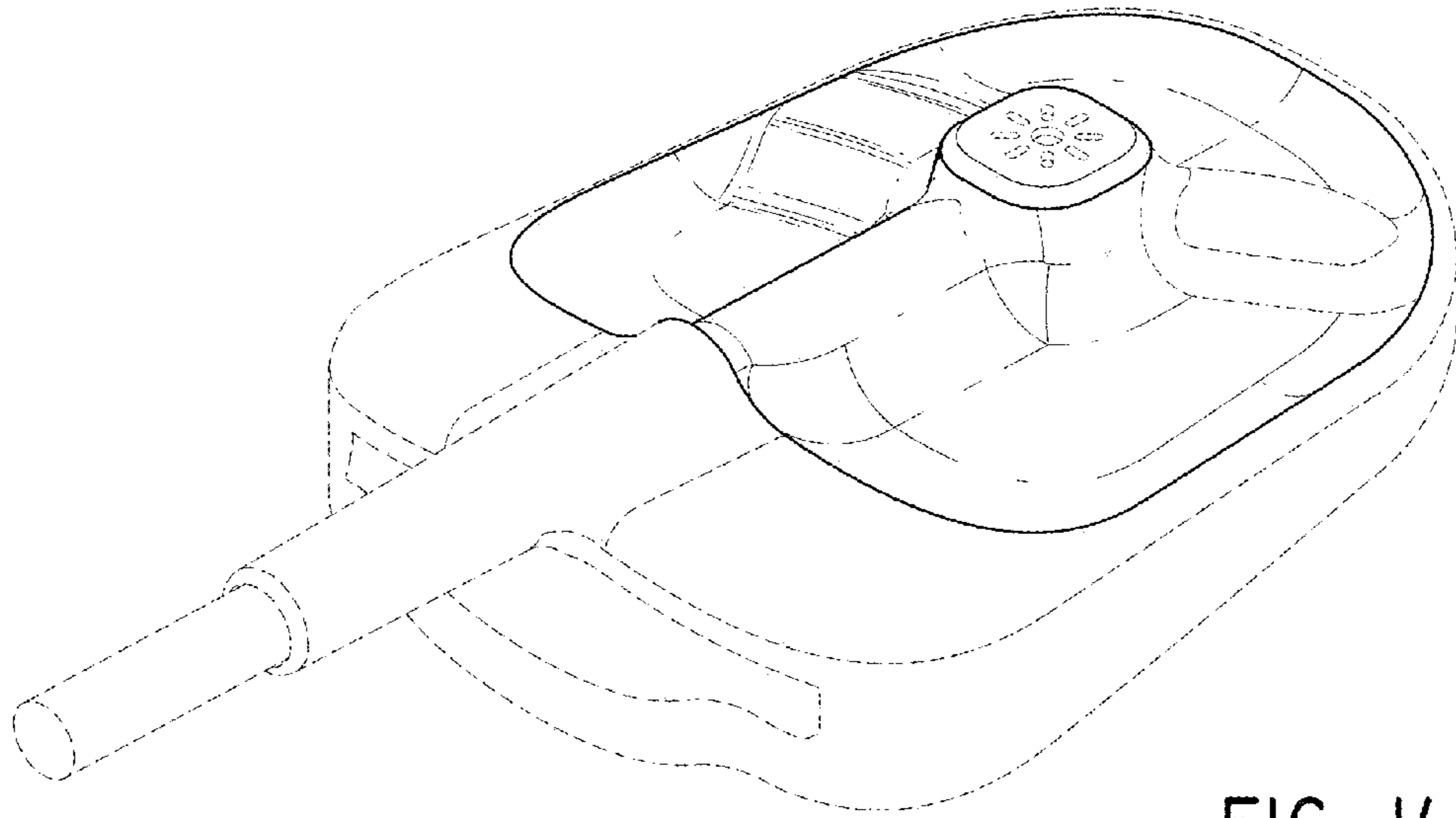

FIG. 14

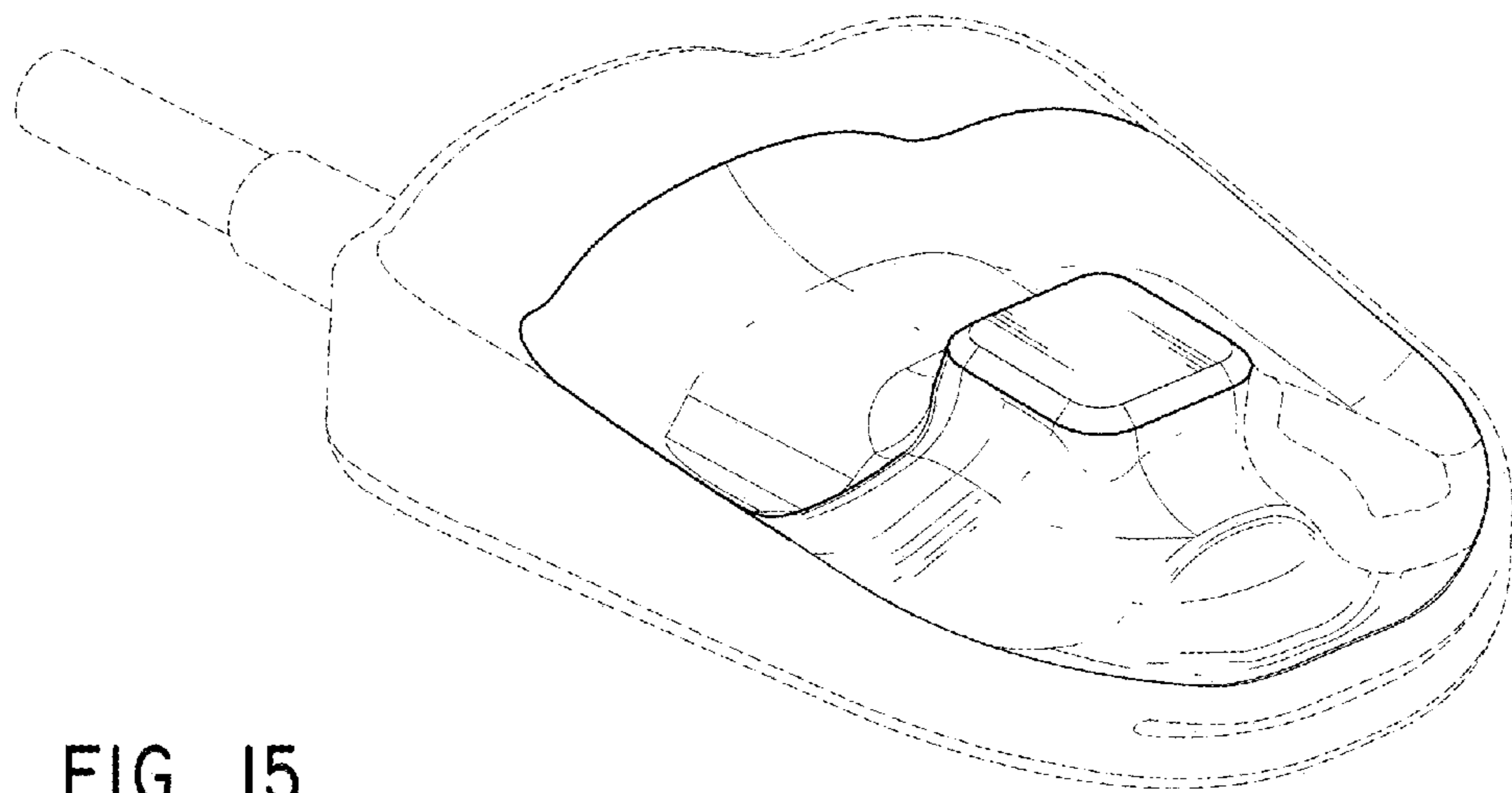

FIG. 15

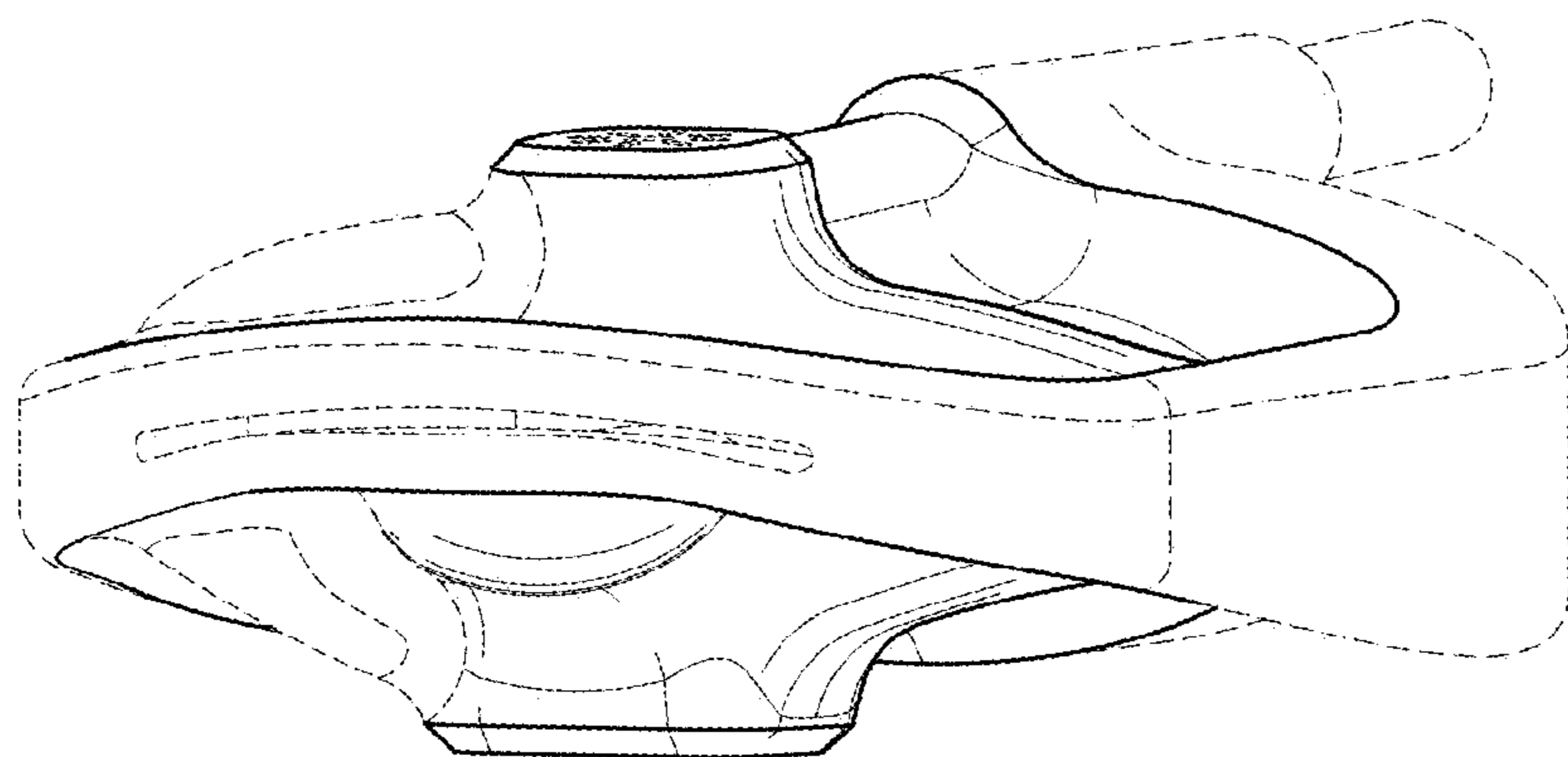

FIG. 16

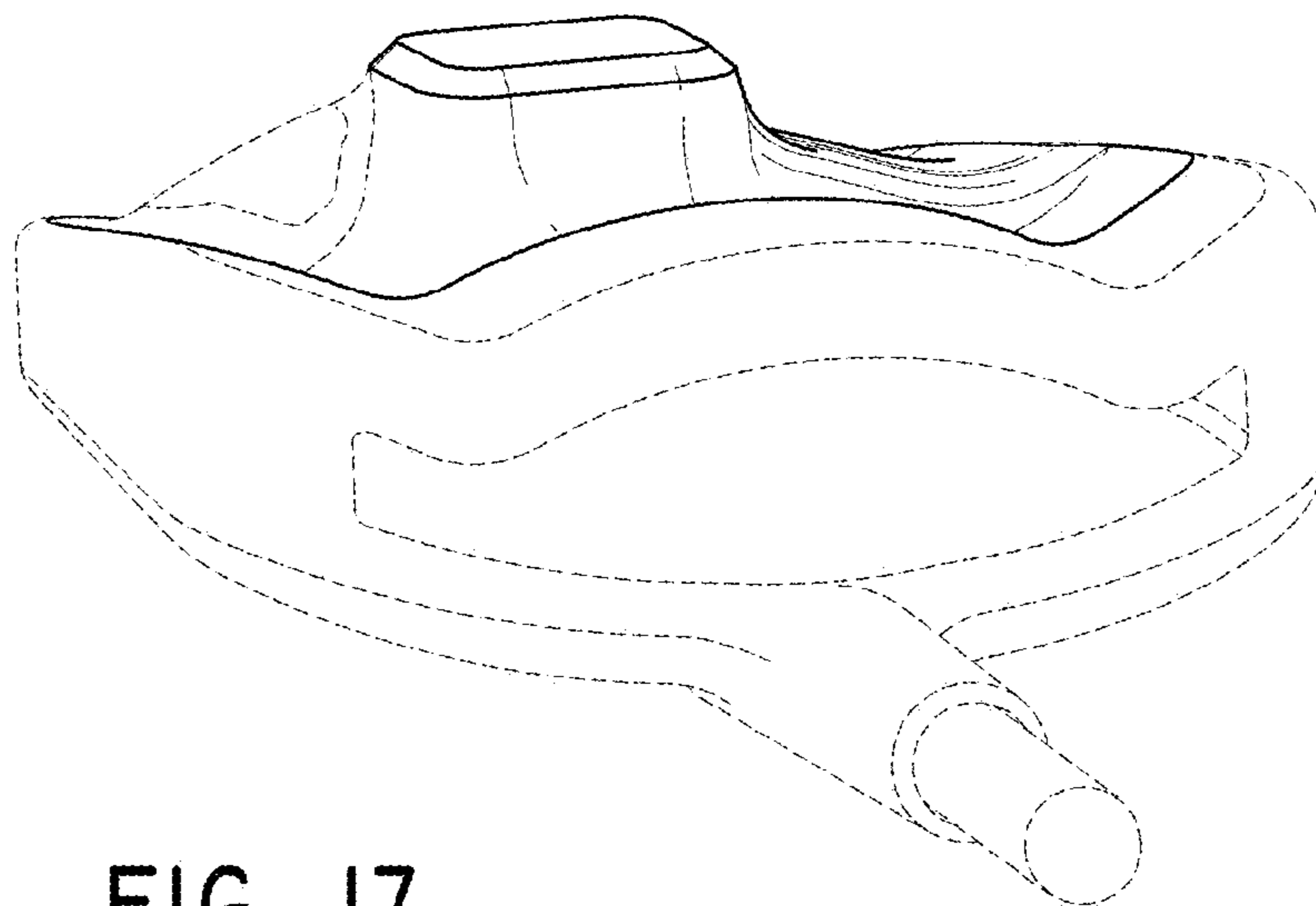

FIG. 17

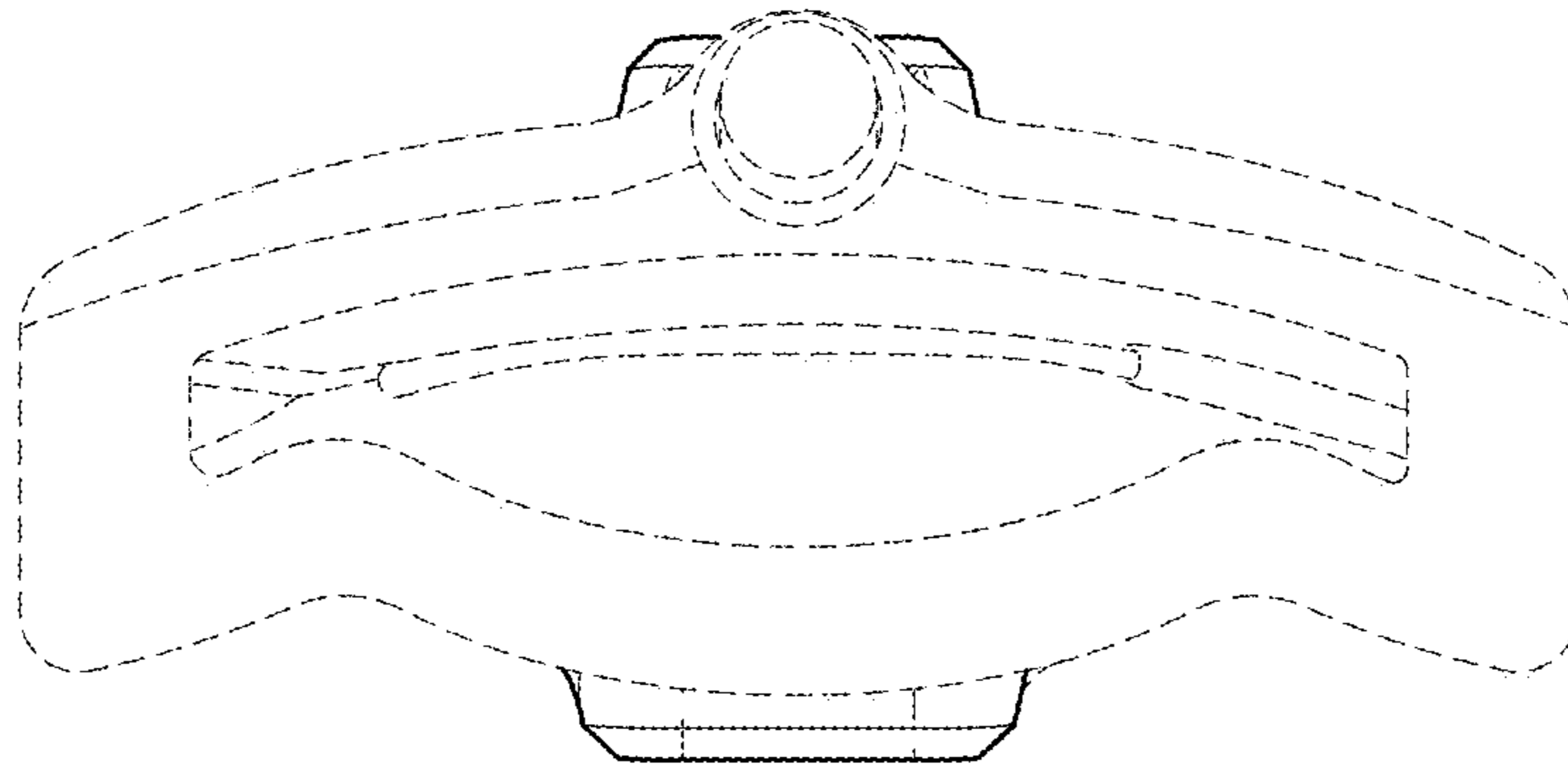

FIG. 18

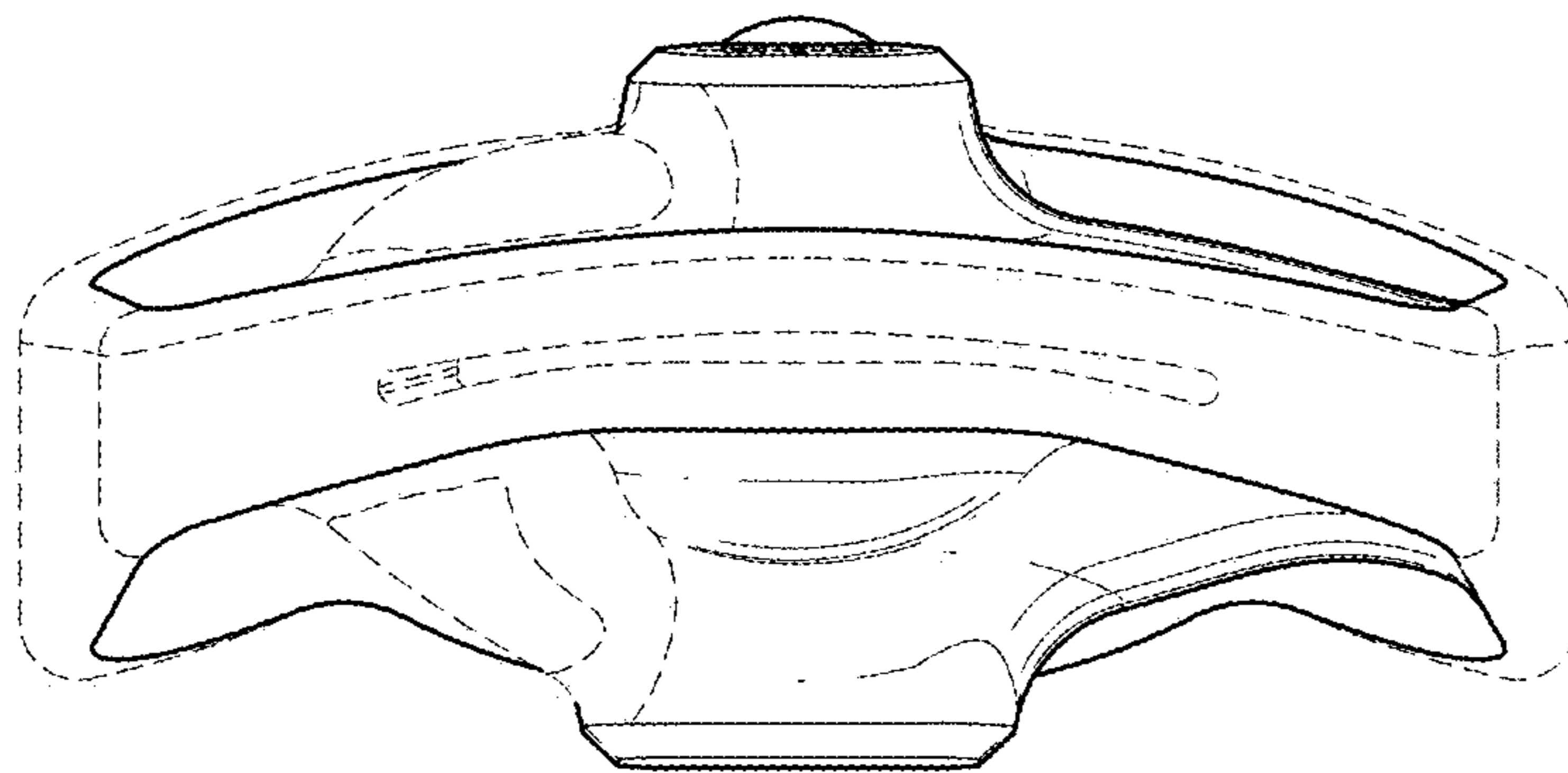

FIG. 19

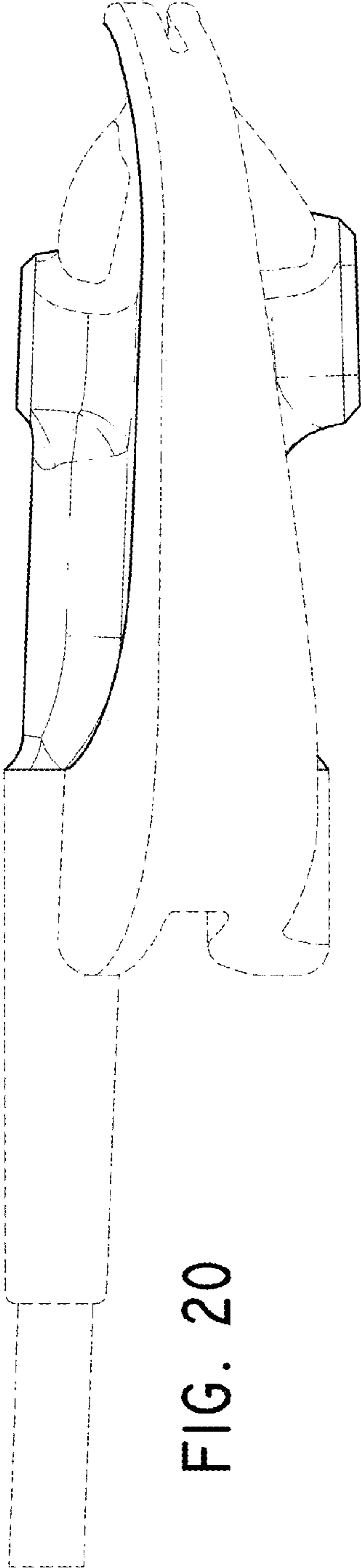

FIG. 20

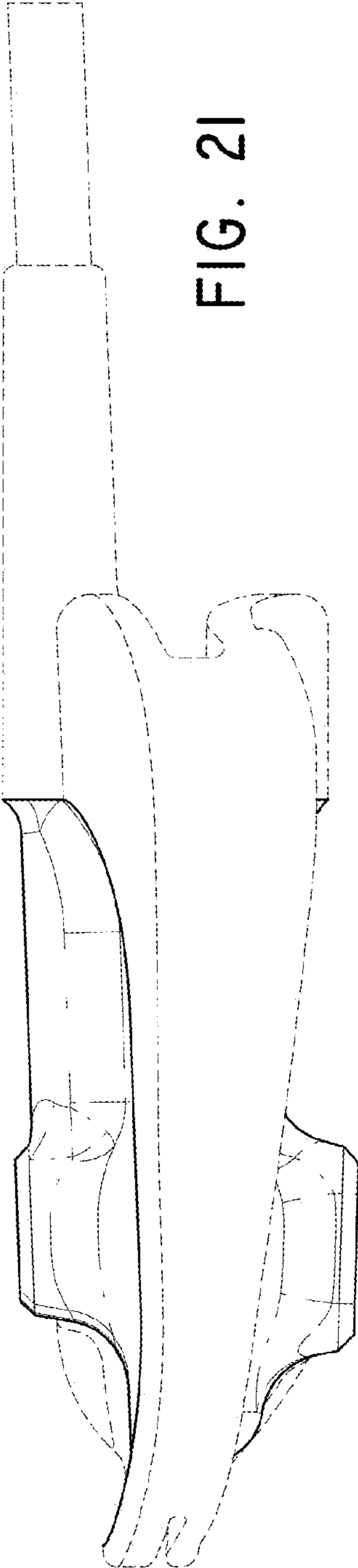

FIG. 21

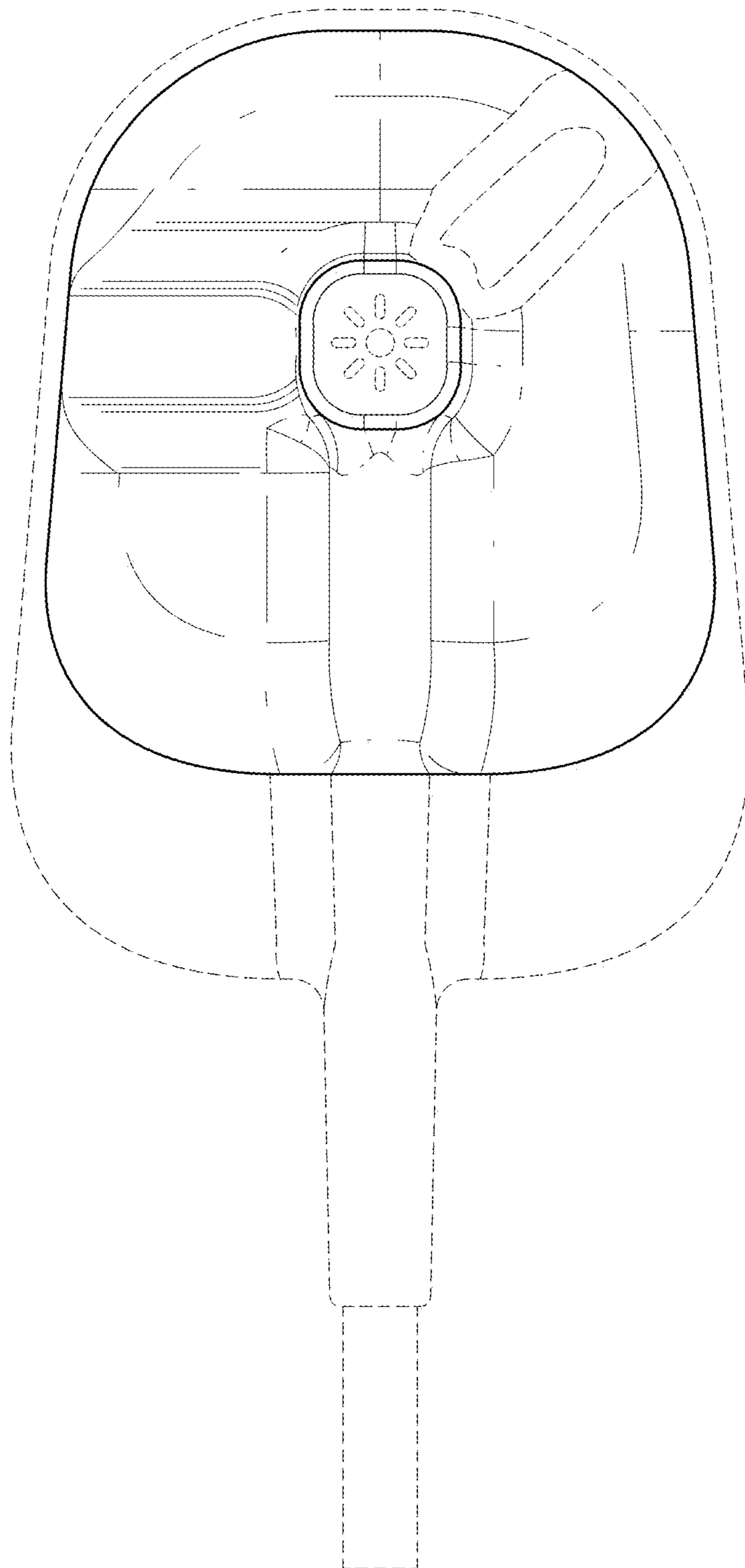

FIG. 22

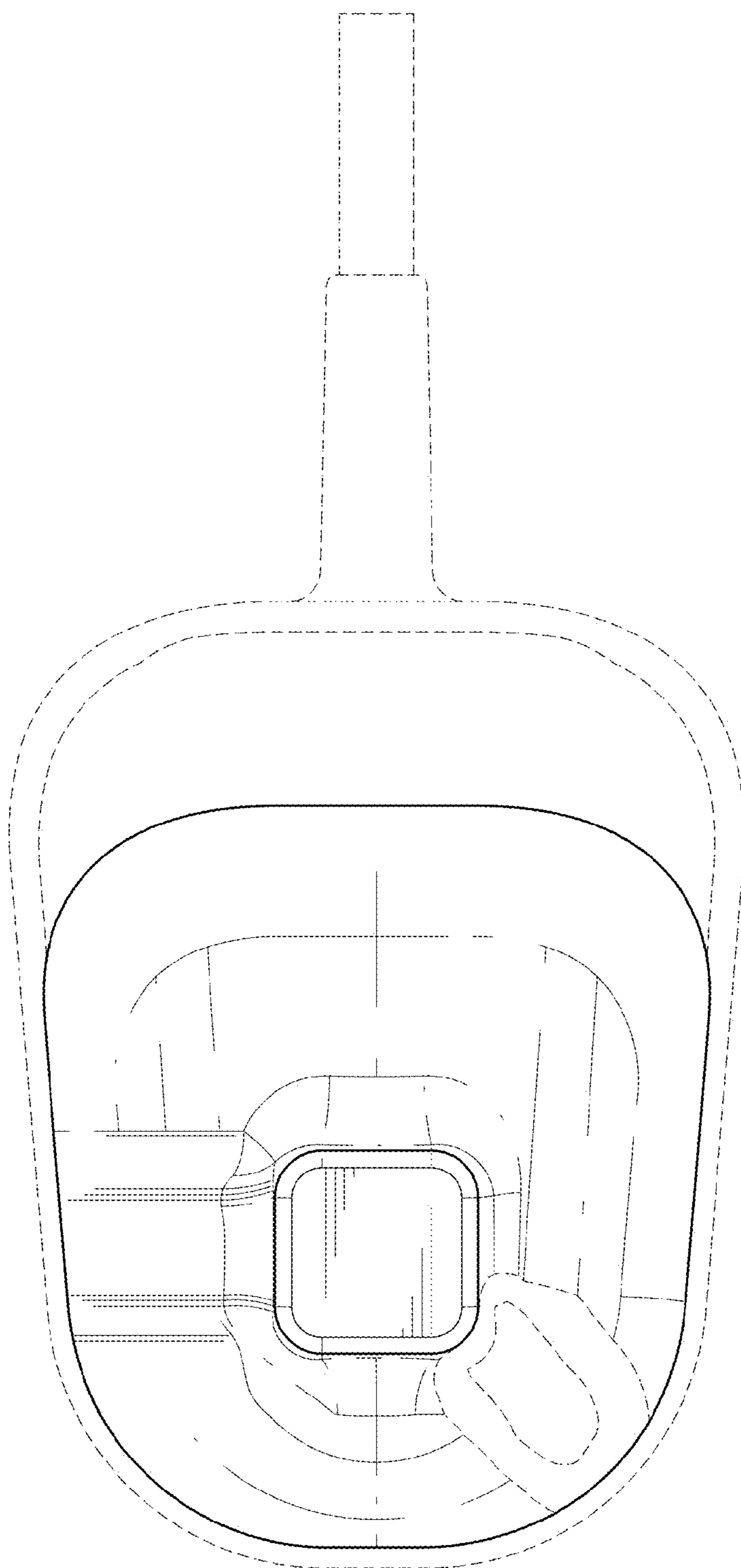

FIG. 23