



US00D755329S

(12) **United States Design Patent**  
**Kielsmeier et al.**

(10) **Patent No.:** **US D755,329 S**

(45) **Date of Patent:** **\*\* May 3, 2016**

(54) **CHEEK REST FOR A FIREARM**

(71) Applicant: **Magpul Industries Corporation**, Erie, CO (US)

(72) Inventors: **Nicholas Kielsmeier**, Denver, CO (US); **Thomas D. Ward, Jr.**, Tualatin, CO (US); **William B. Bennett**, Lafayette, CO (US); **Michael T. Mayberry**, Denver, CO (US); **Richard Fitzpatrick**, West Lake Hills, TX (US); **Grady Barfoot**, Denver, CO (US); **Timothy Roberts**, Erie, CO (US)

(73) Assignee: **Magpul Industries Corporation**, Louisville, CO (US)

(\*\*) Term: **14 Years**

(21) Appl. No.: **29/504,958**

(22) Filed: **Oct. 10, 2014**

**Related U.S. Application Data**

(63) Continuation of application No. 29/497,272, filed on Jul. 22, 2014.

(51) **LOC (10) Cl.** ..... **22-01**

(52) **U.S. Cl.**  
USPC ..... **D22/108**

(58) **Field of Classification Search**  
USPC ..... D22/103, 108  
CPC ..... F41C 23/04; F41C 23/14; F41C 23/06;  
F41C 23/22; F41C 33/007  
See application file for complete search history.

(56) **References Cited**

**U.S. PATENT DOCUMENTS**

922,173 A 5/1909 Lovelace  
1,032,628 A 7/1912 Sherman

(Continued)

**OTHER PUBLICATIONS**

Magpul\_CTR\_MOE\_025\_CHEEK\_RISER Magpul Industries Corporation CTR®/MOE® 0.25" CHEEK RISER; Website [Online] Available Website: <http://www.magpul.com/products/ctr%C2%AE-moe%C2%AE-0-25-cheek-riser?VariantID=VO343>; Last Update: Unknown; Accessed on: Jan. 30, 2015.

(Continued)

*Primary Examiner* — Michael A Pratt

(74) *Attorney, Agent, or Firm* — Swanson & Bratschun, L.L.C.

(57) **CLAIM**

The ornamental design for a cheek rest for a firearm, as shown and described.

**DESCRIPTION**

FIG. 1 is a top, right, rear perspective view of a first embodiment of a cheek rest for a firearm shown deployed on a top side of a folding firearm stock shown in broken lines, the top, left, rear perspective view being a mirror image of the first embodiment of a cheek rest;

FIG. 2 is a top, right, rear perspective view a second embodiment of a cheek rest for a firearm shown deployed on a top side of a folding firearm stock shown in broken lines, the top, left, rear perspective view being a mirror image of the second embodiment of a cheek rest, the second embodiment of the cheek rest differing from the first embodiment of the cheek rest only by the height the cheek rest extends above the top side of a folding firearm stock; and,

FIG. 3 is a top, right, rear perspective view of a third embodiment of a cheek rest for a firearm shown deployed on a top side of a folding firearm stock shown in broken lines, the top, left, rear perspective view being a mirror image of the third embodiment of a cheek rest, the third embodiment of the cheek rest differing from the second embodiment of the cheek rest only by the height the cheek rest extends above the top side of a folding firearm stock.

The broken lines showing portions of the design in all figures are included for the purpose of illustrating environment and unclaimed features and form no part of the claimed design.

**1 Claim, 3 Drawing Sheets**

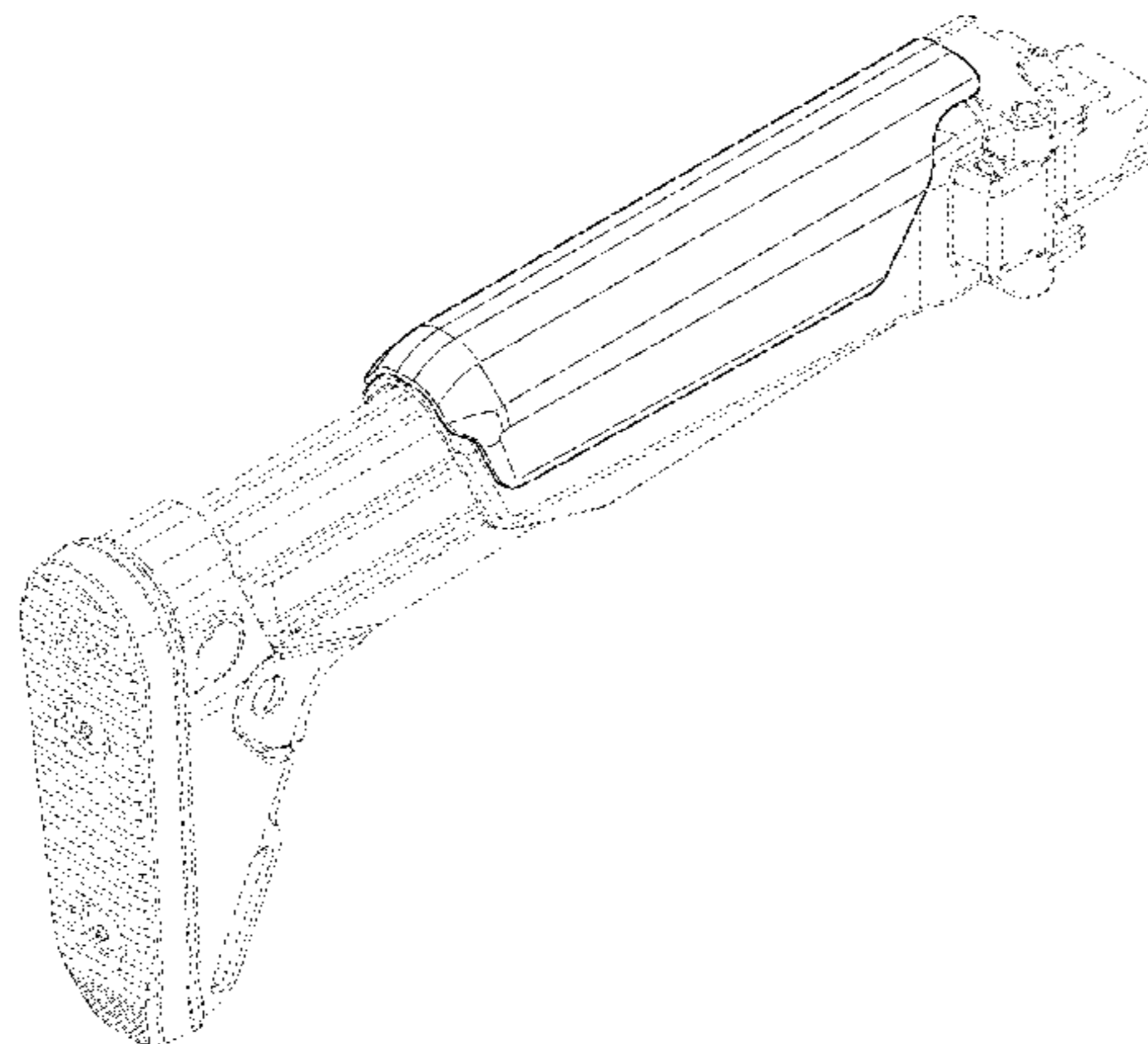



(56)

References Cited

U.S. PATENT DOCUMENTS

1,651,299 A 11/1927 Stansel  
 D196,304 S 9/1963 Hoge  
 3,618,249 A 11/1971 Grandy  
 3,710,496 A 1/1973 Packmayr  
 D241,836 S 10/1976 Ruger  
 4,120,108 A 10/1978 Vickers  
 4,122,623 A 10/1978 Stice  
 4,203,243 A 5/1980 Hickman  
 4,589,219 A 5/1986 Milliman  
 4,663,877 A 5/1987 Bragg  
 D297,855 S 9/1988 Ruger  
 4,788,785 A 12/1988 White  
 D304,223 S 10/1989 Ruger  
 4,896,446 A 1/1990 Gregory  
 5,031,348 A 7/1991 Carey  
 5,075,995 A 12/1991 Kennel  
 D324,557 S 3/1992 Livingston  
 5,933,997 A 8/1999 Barrett  
 D462,104 S 8/2002 McCarthy  
 6,598,330 B2 7/2003 Garrett  
 6,637,141 B1 10/2003 Weatherby  
 D514,123 S 1/2006 Naruki  
 D516,660 S 3/2006 Murello  
 D516,807 S 3/2006 Richardson  
 D517,637 S 3/2006 Murello  
 7,162,823 B2 1/2007 Schoppman  
 D551,313 S 9/2007 Saur  
 D589,578 S 3/2009 Choma  
 D603,013 S 10/2009 Fitzpatrick  
 D606,614 S 12/2009 Fitzpatrick  
 7,647,719 B2 1/2010 Fitzpatrick  
 7,827,722 B1 11/2010 Davies  
 D636,833 S 4/2011 Mayberry  
 D636,834 S 4/2011 Mayberry  
 D639,891 S 6/2011 Chvala  
 D640,342 S 6/2011 Fitzpatrick  
 D645,110 S 9/2011 Cook  
 D645,533 S 9/2011 Peterson  
 D648,412 S 11/2011 Cook  
 D661,366 S 6/2012 Zusman  
 D661,768 S 6/2012 Keng  
 D668,311 S 10/2012 Rogers  
 D676,921 S 2/2013 Fitzpatrick  
 D680,611 S 4/2013 Emde  
 D680,613 S 4/2013 Fitzpatrick  
 D681,151 S 4/2013 Fitzpatrick  
 D683,808 S 6/2013 Elkaim  
 D688,768 S 8/2013 Fitzpatrick  
 D691,234 S 10/2013 Fitzpatrick  
 D692,087 S 10/2013 Fitzpatrick  
 D695,377 S 12/2013 Mayberry  
 D700,265 S 2/2014 Mayberry et al.  
 8,656,622 B2 2/2014 Peterson  
 D704,294 S 5/2014 Jarboe  
 8,720,099 B1 5/2014 Sisk  
 D706,879 S 6/2014 Chu  
 8,763,296 B1 \* 7/2014 Chvala ..... F41C 23/14  
 42/73  
 8,769,853 B1 7/2014 LaRue  
 8,844,185 B2 9/2014 Jarboe  
 D722,669 S 2/2015 Keller  
 D722,671 S 2/2015 Mayberry  
 9,109,854 B1 \* 8/2015 Mazzaccaro ..... F41C 23/06  
 2007/0130817 A1 6/2007 Ballard  
 2007/0180984 A1 8/2007 Huther  
 2008/0028662 A1 2/2008 Abraham  
 2008/0052979 A1 3/2008 Lee  
 2008/0168695 A1 7/2008 Nakayama  
 2008/0236016 A1 10/2008 Fitzpatrick  
 2008/0236017 A1 10/2008 Fitzpatrick  
 2009/0241397 A1 10/2009 Fitzpatrick  
 2010/0115817 A1 5/2010 Faifer  
 2010/0205846 A1 8/2010 Fitzpatrick  
 2010/0251590 A1 10/2010 Fitzpatrick  
 2010/0275489 A1 11/2010 Cabahug

2011/0173863 A1 7/2011 Ingram  
 2011/0192067 A1 8/2011 Troy  
 2011/0283586 A1 11/2011 Scallie  
 2012/0073177 A1 3/2012 Laney  
 2012/0174455 A1 7/2012 Edelman  
 2012/0174456 A1 7/2012 Depierro  
 2012/0174457 A1 7/2012 Edelman  
 2012/0279384 A1 11/2012 Hochstrate  
 2014/0196343 A1 \* 7/2014 Wilson ..... F41C 23/14  
 42/71.01  
 2014/0283428 A1 \* 9/2014 Slater ..... F41C 23/14  
 42/71.01

OTHER PUBLICATIONS

Magpul\_CTR\_MOE\_050\_CHEEK\_RISER Magpul Industries Corporation CTR®/MOE® 0.50" CHEEK RISER; Website [Online] Available Website: <http://www.magpul.com/products/ctr%C2%AE-moe%C2%AE-0-50-cheek-riser?VariantID=VO343%22>; Last Update: Unknown; Accessed on: Jan. 30, 2015.  
 Magpul\_CTR\_MOE\_075\_CHEEK\_RISER Magpul Industries Corporation CTR®/MOE® 0.75" CHEEK RISER; Website [Online] Available Website: <http://www.magpul.com/products/ctr%C2%AE-moe%C2%AE-0-75-cheek-riser?VariantID=VO343>; Last Update: Unknown; Accessed on: Jan. 30, 2015.  
 Design U.S. Appl. No. 29/486,193, "Firearm Stock" filed Mar. 27, 2014.  
 Design U.S. Appl. No. 29/486,201, "Stock Butt Pad" filed Mar. 27, 2014.  
 Design U.S. Appl. No. 29/497,272, "Folding Firearm Stock" filed Jul. 22, 2014.  
 Design U.S. Appl. No. 29/508,882, "Firearm Stock" filed Nov. 12, 2014.  
 Design U.S. Appl. No. 29/512,719, "Fixed Stock for a Firearm" filed Dec. 22, 2014.  
 Command Arms Accessories Online Catalog (2008) SRS Product Information.  
 Defensive\_Edge\_Sully\_Stock Defensive Edge Training and Consulting, Inc. Online Catalog (2010) "Sully Stock" Available Website: [http://www.thedefensiveedge.com/category\\_s/51.htm](http://www.thedefensiveedge.com/category_s/51.htm); Last Update: Unknown.  
 Heckler & Koch Online Catalog (2008) PSG1A1 Product Information.  
 Magpul Online Catalog (2007) FAL Preproduction Product Information.  
 Magpul Online Catalog (2007) PRS Ar15/M16 Product Information.  
 Magpul\_2012\_SGA\_High\_Cheek\_Riser\_Kit Magpul Industries Corporation (Jan. 20, 2012) SGA® High Cheek Riser Kit; Website [Online] Available Website: <http://store.magpul.com/product/MAG461/shotgun>; Last Update: Jul. 1, 2014; Accessed on: Nov. 13, 2014.  
 Magpul\_2012\_SGA\_Low\_Cheek\_Riser\_Kit Magpul Industries Corporation (Date) SGA® Low Cheek Riser Kit; Website [Online] Available Website: <http://store.magpul.com/product/MAG463/shotgun>; Last Update: Jul. 2, 2014; Accessed on: Nov. 13, 2014.  
 Magpul\_2013\_SGA\_Receiver\_Sling\_Mount Magpul Industries Corporation (Jan. 18, 2013) SGA® Receiver Sling Mount—Mossberg 500/590/590A1 SGA Stock; Website [Online] Available Website: <http://store.magpul.com/product/MAG492/shotgun>; Last Update: Jul. 27, 2014; Accessed on: Nov. 13, 2014.  
 Magpul\_2013\_SGA\_Stock\_Mossberg\_500\_590\_590A1\_Shotgun Magpul Industries Corporation (Jan. 18, 2013) SGA® Stock—Mossberg 500/590/590A1 Shotgun; Website [Online] Available Website: <http://store.magpul.com/product/MAG490/shotgun>; Last Update: Jul. 1, 2014; Accessed on: Nov. 13, 2014.  
 Total\_Silence\_Home\_of\_the\_XM607\_Buttstock TSI Online Catalog (2011) "Total Silence—Home of the XM607 Buttstock" Available Website: <http://totalsilenceinc.com/>; Last Update: Unknown.  
 Design U.S. Appl. No. 29/302,198, filed Jan. 11, 2008, "Automatic Rifle" by Fitzpatrick.  
 Design U.S. Appl. No. 29/399,326, filed Aug. 12, 2011, "ACS Rifle Stock" by Fitzpatrick.

(56)

**References Cited**

OTHER PUBLICATIONS

Design U.S. Appl. No. 29/403,627, filed Oct. 7, 2011, "Stock for Firearm" by Mayberry.

Design U.S. Appl. No. 29/405,857, filed Nov. 7, 2011, "Stock for a Firearm" by Fitzpatrick Issued.

Design U.S. Appl. No. 29/410,910, filed Jan. 13, 2012, "PMAG 30M3 Firearm Magazine" by Fitzpatrick Issued.

Design U.S. Appl. No. 29/420,155, filed May 4, 2012, "Translucent Magazine for a Firearm" by Fitzpatrick.

Design U.S. Appl. No. 29/423,116, filed May 29, 2012, "M3 10 Magazine" by Bennett Issued.

Design U.S. Appl. No. 29/423,117, filed May 29, 2012, "M3 20 Magazine" by Bennett.

Design U.S. Appl. No. 29/440,787, filed Dec. 27, 2012, "Firearm Magazine" by Mayberry.

Design U.S. Appl. No. 29/440,889, filed Dec. 28, 2012, "Firearm Magazine" by Kielsmeier.

Design U.S. Appl. No. 29/440,792, filed Dec. 27, 2012, "Firearm Magazine with Window" by Kielsmeier.

Design U.S. Appl. No. 29/450,963, filed Mar. 26, 2013, "Magazine for a Firearm" by Nakayama.

Design U.S. Appl. No. 29/450,964, filed Mar. 26, 2013, "Magazine for a Firearm" by Nakayama.

\* cited by examiner

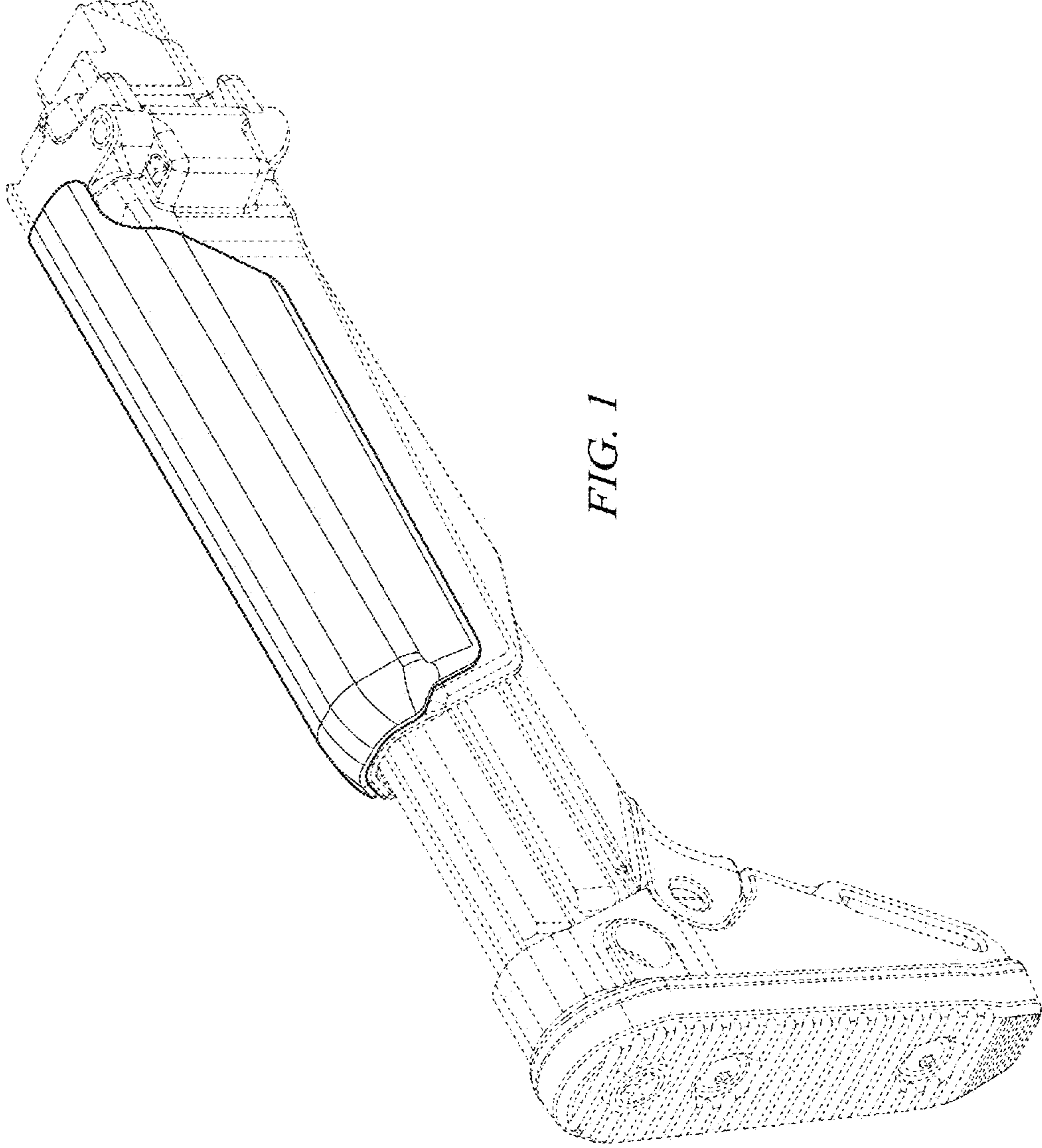

FIG. 1



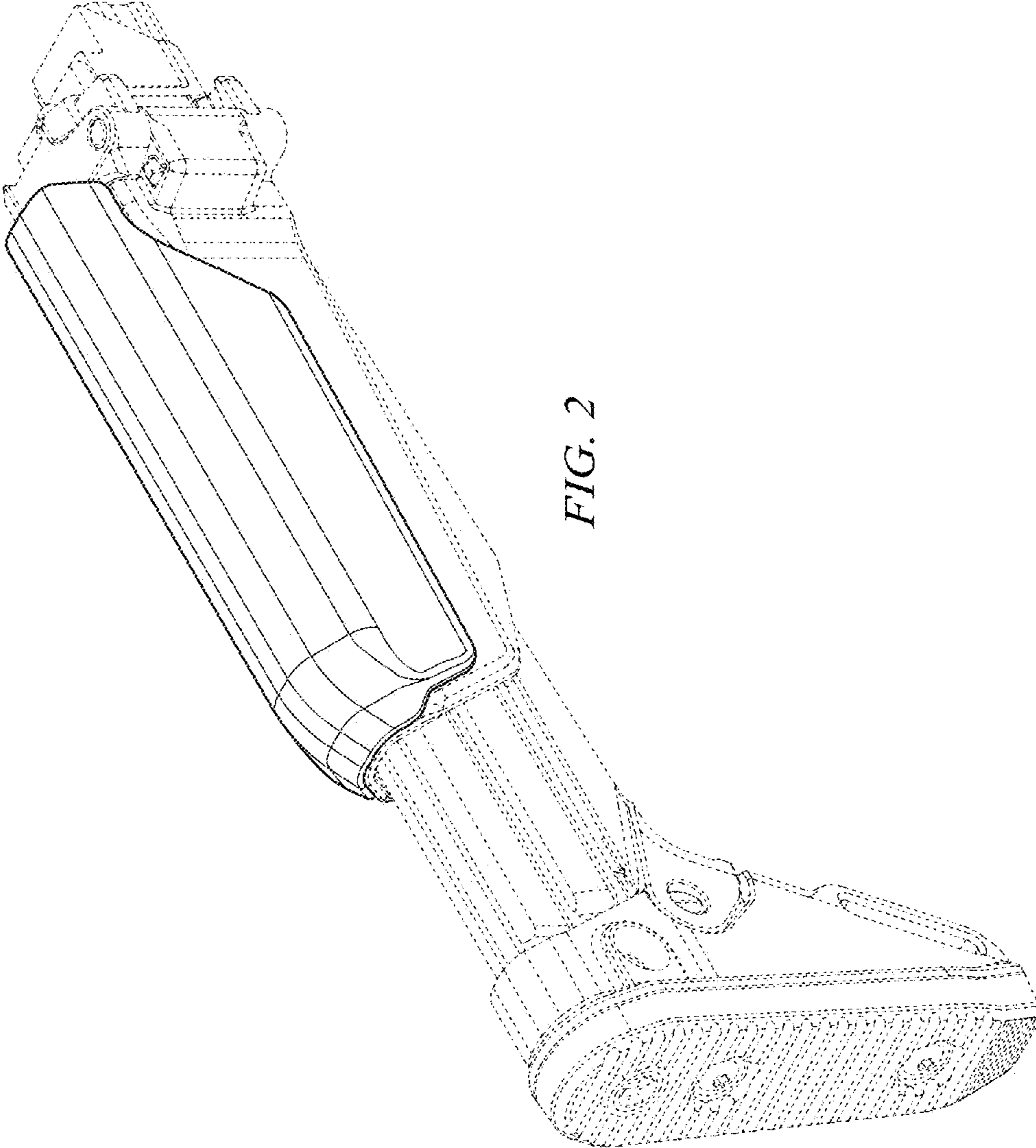

FIG. 2

