



US00D755246S

(12) **United States Design Patent**
Lamparelli

(10) **Patent No.:** **US D755,246 S**

(45) **Date of Patent:** **** May 3, 2016**

(54) **PROPULSION CONTROL SYSTEM FOR SHIP WITH A DISPLAY**

(71) Applicant: **Wartsila Finland Oy**, Vaasa (FI)

(72) Inventor: **Davide Lamparelli**, Fitjar (NO)

(73) Assignee: **WARTSILA FINLAND OY**, Vaasa (FI)

(**) Term: **15 Years**

(21) Appl. No.: **29/536,594**

(22) Filed: **Aug. 18, 2015**

Related U.S. Application Data

(62) Division of application No. 29/454,667, filed on May 13, 2013, now Pat. No. Des. 742,418.

(30) **Foreign Application Priority Data**

Nov. 13, 2012 (EM) 002134809

Nov. 13, 2012 (EM) 002135004

Nov. 13, 2012 (EM) 002135038

(51) **LOC (10) Cl.** **15-01**

(52) **U.S. Cl.**

USPC **D15/4**; D12/317

(58) **Field of Classification Search**

USPC D15/5, 4; D12/300, 301, 303-315, 317, D12/174, 178-180; D13/134, 168, 169, D13/173; D10/49; 74/469, 473.1-473.12, 74/473.19, 473.2, 590 B, 491; 440/84-87, 440/98, 111, 112, 113

CPC B63H 21/21; B63H 21/213; B63H 25/00; B63H 2025/026; B63H 25/46; Y10T 137/87064; Y10T 74/20732; Y10T 74/20612; Y10T 37/87072; Y10T 74/20636; Y10T 74/20201; F02D 11/106; F02D 41/2464; H01H 2217/04; H01H 2221/008; H01H 25/008

See application file for complete search history.

(56) **References Cited**

U.S. PATENT DOCUMENTS

6,538,217 B1 * 3/2003 Eriksen B63H 21/213
114/144 RE

D573,936 S 7/2008 Jin

D581,855 S 12/2008 Arol

D593,481 S * 6/2009 Kobelt D12/317

D663,253 S 7/2012 Bondesson

D663,254 S 7/2012 Bondesson

8,406,944 B2 3/2013 Garon et al.

D689,423 S 9/2013 Park et al.

(Continued)

Primary Examiner — T. Chase Nelson

Assistant Examiner — Ania Aman

(74) *Attorney, Agent, or Firm* — Muncy, Geissler, Olds & Lowe, P.C.

(57) **CLAIM**

The ornamental design for a propulsion control system for ship with a display as, shown and described.

DESCRIPTION

FIG. 1 is a perspective view of a first embodiment of a propulsion control system for ship with a display;

FIG. 2 is a right side view thereof;

FIG. 3 is a left side view thereof;

FIG. 4 is a top plan view thereof;

FIG. 5 is a front elevational view thereof;

FIG. 6 is a rear elevational view thereof;

FIG. 7 is a perspective view of a second embodiment of a propulsion control system for ship with a display;

FIG. 8 is a right side view thereof;

FIG. 9 is a left side view thereof;

FIG. 10 is a top plan view thereof;

FIG. 11 is a front elevational view thereof; and,

FIG. 12 is a rear elevational view thereof.

The broken line showing is for the purpose of illustrating portions of the propulsion control system for a ship with a display which form no part of the claimed design.

1 Claim, 12 Drawing Sheets

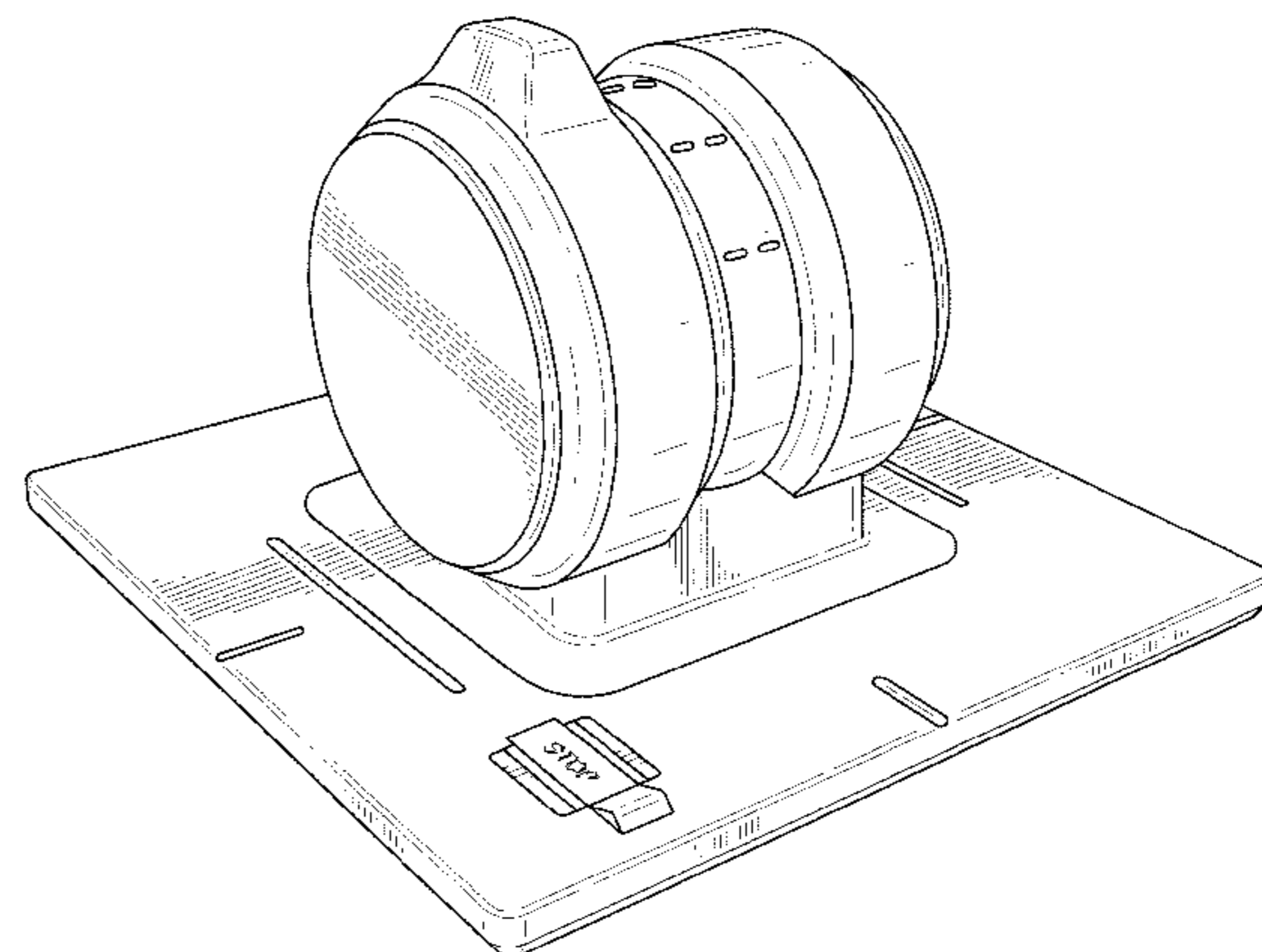
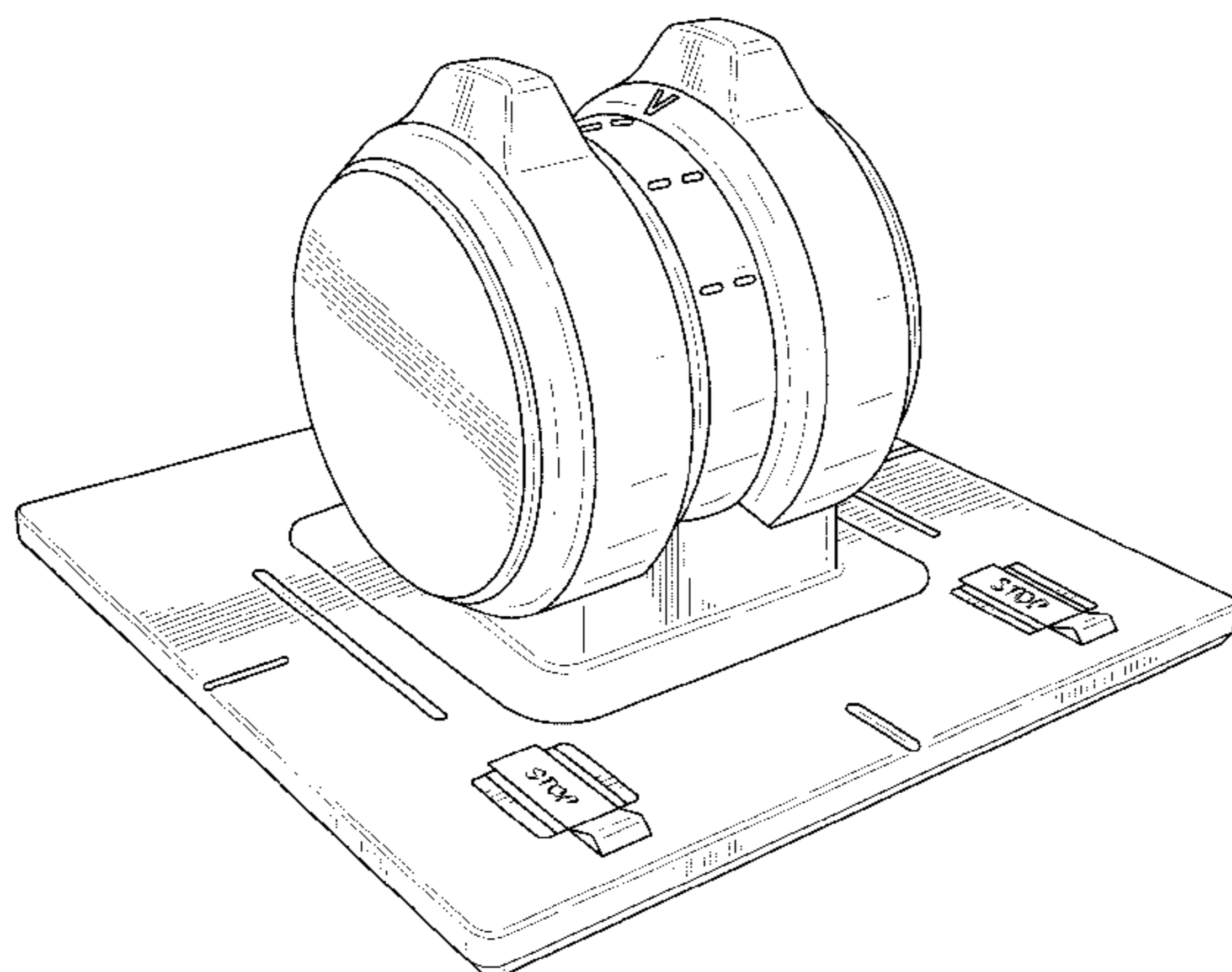

(56)

References Cited

U.S. PATENT DOCUMENTS

D689,424 S 9/2013 Park et al.
D710,781 S 8/2014 Park et al.

8,925,414 B1 1/2015 Park et al.
8,930,050 B2 1/2015 Garon et al.
2007/0249244 A1 10/2007 Watanabe et al.

* cited by examiner

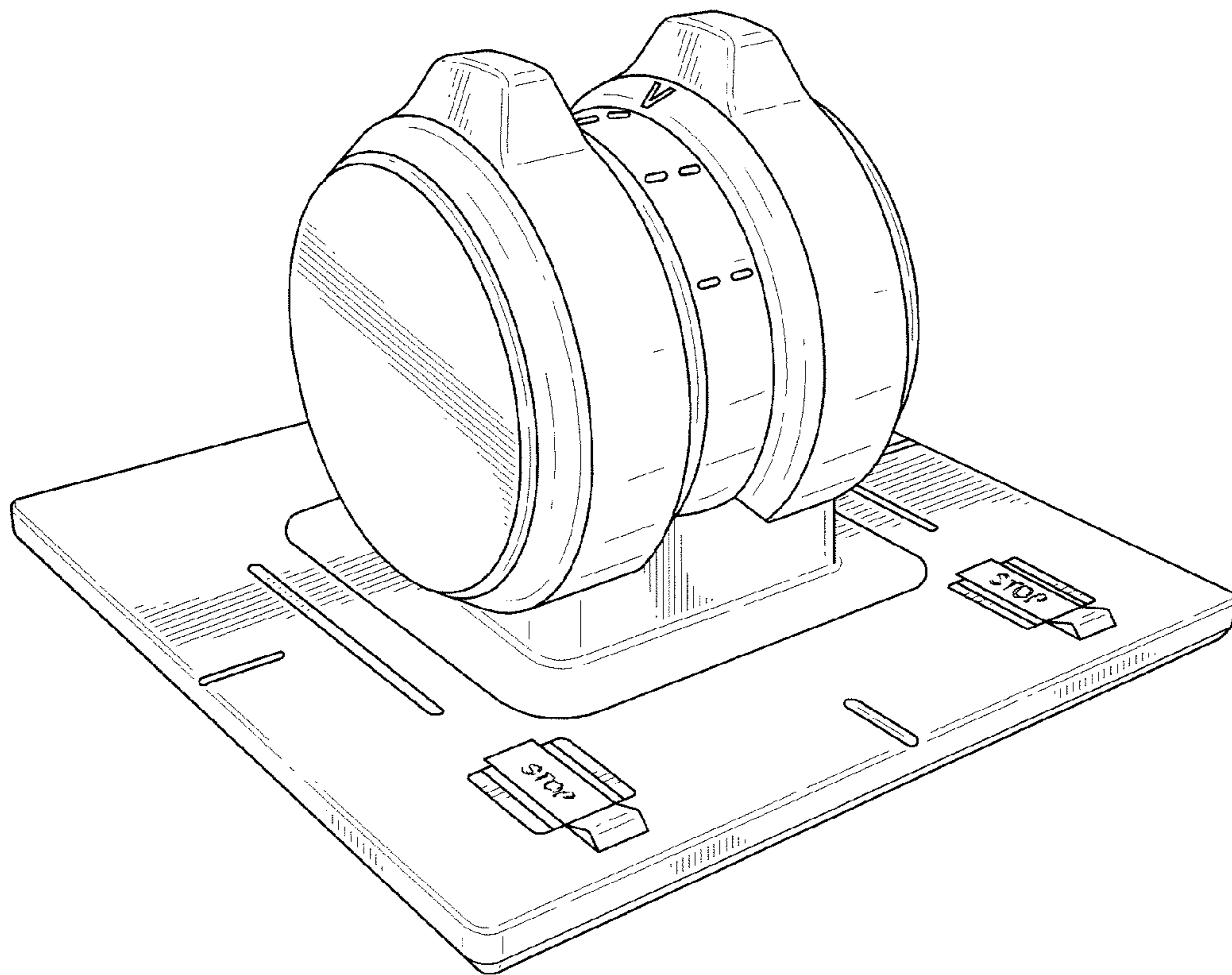

FIG. 1

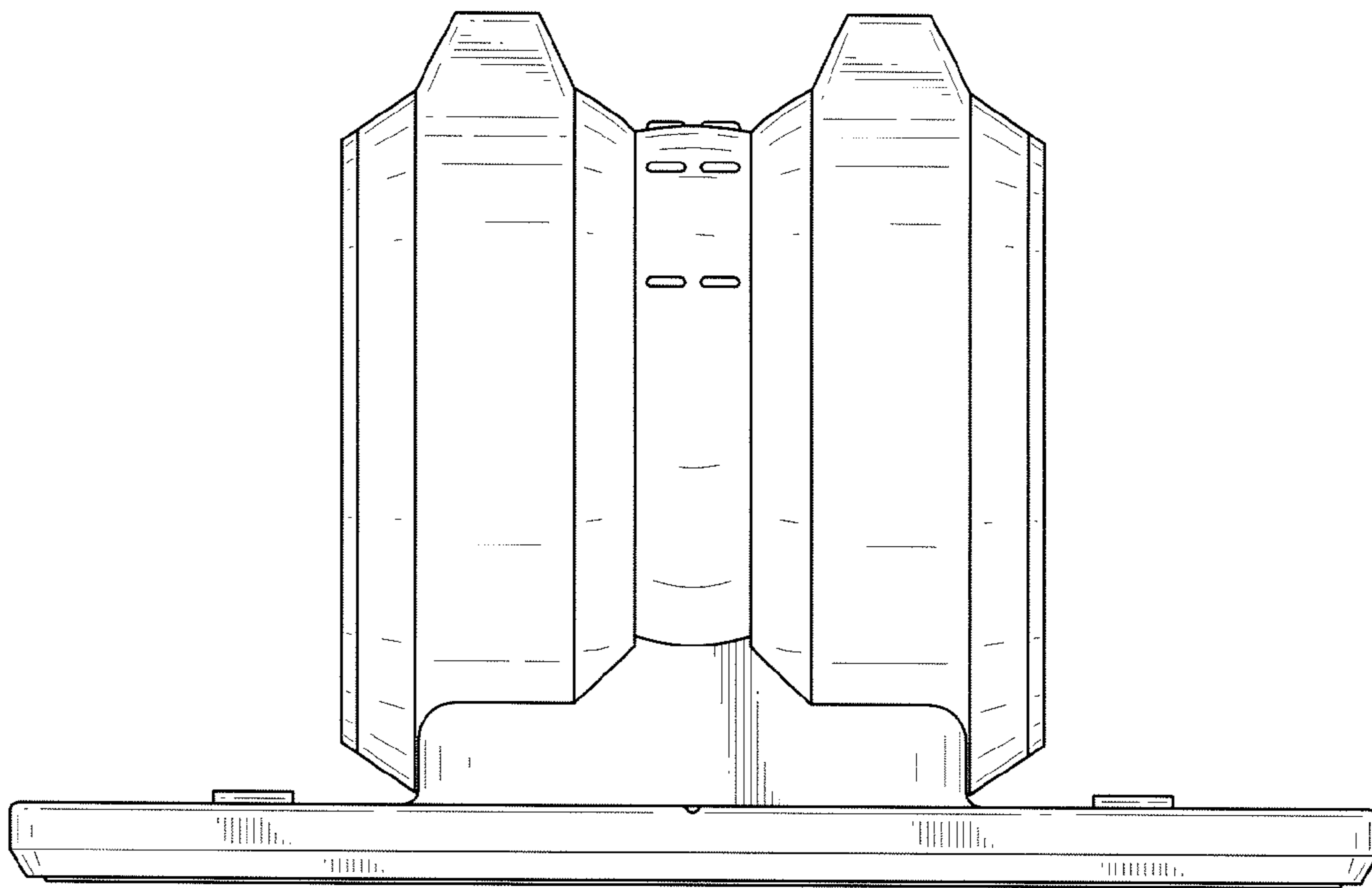

FIG. 2

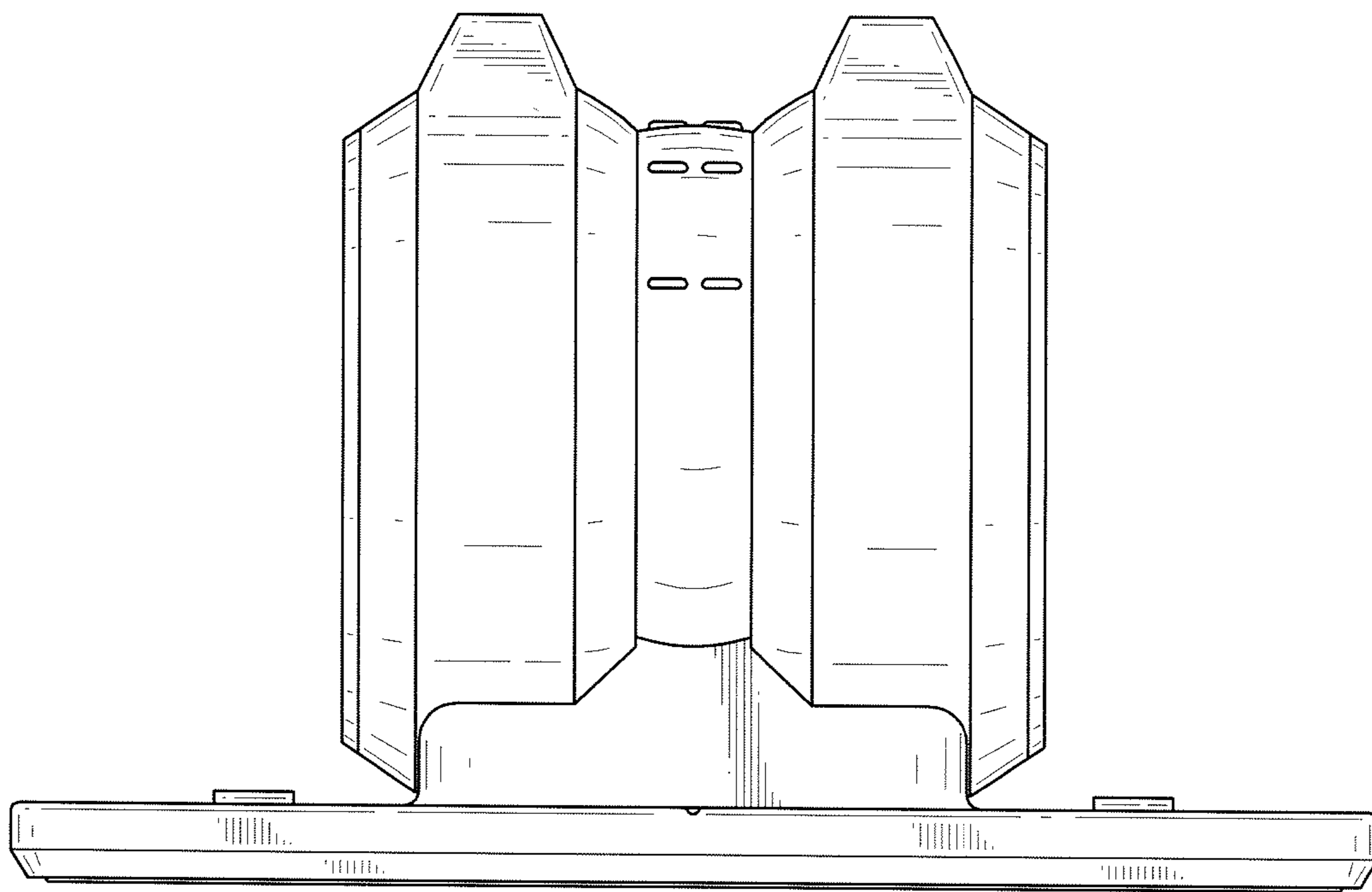

FIG. 3

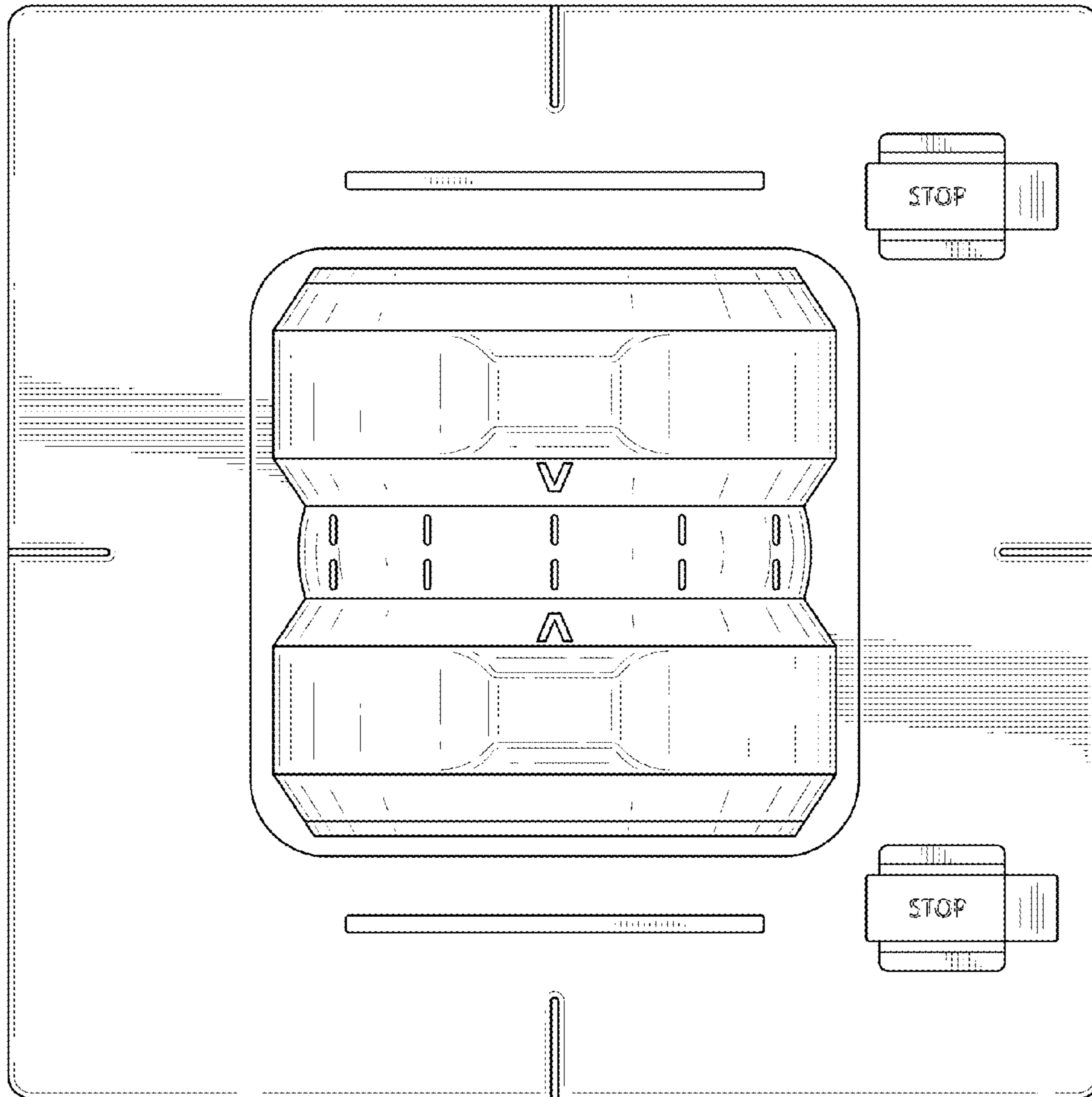

FIG.4

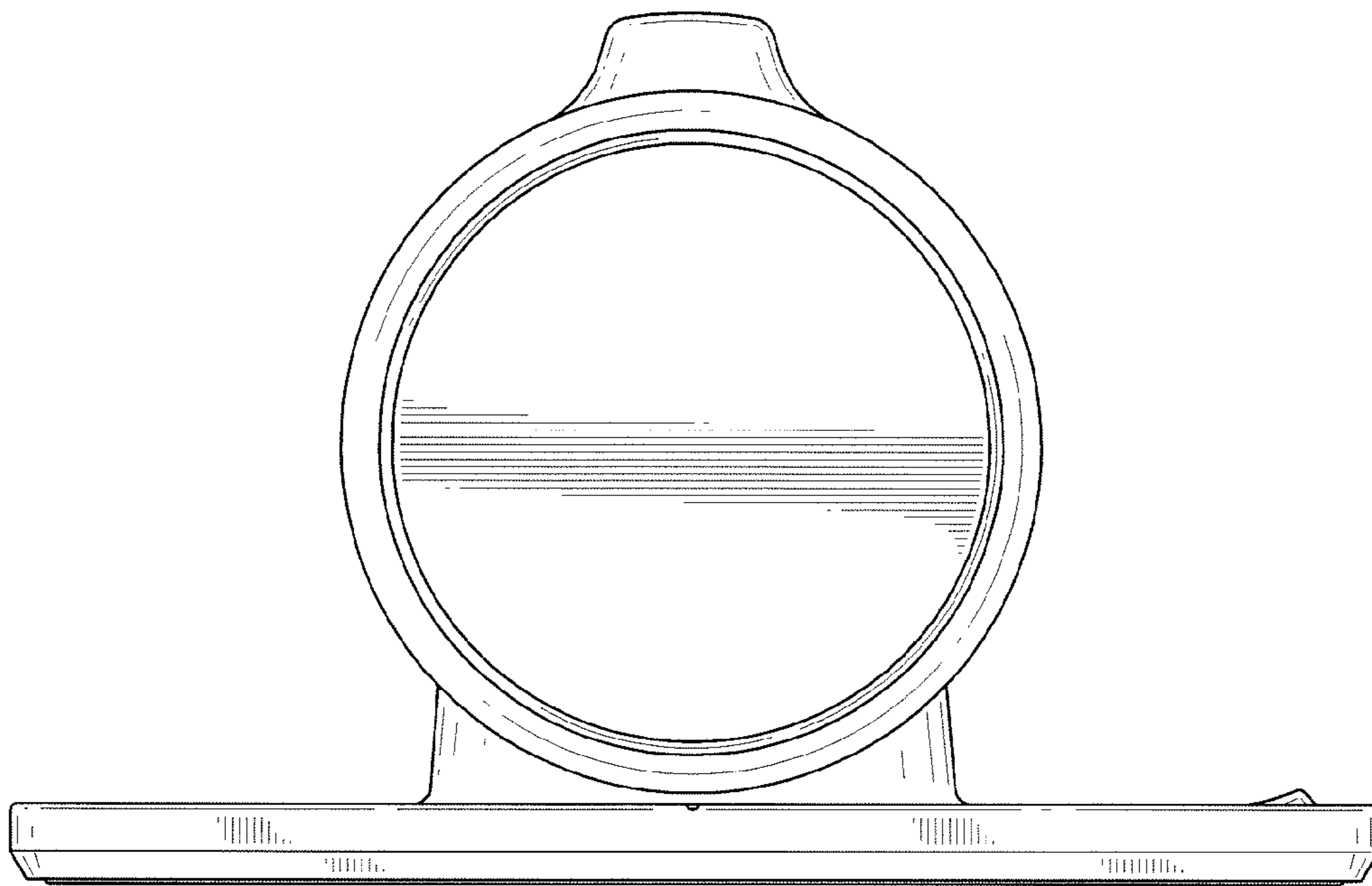

FIG. 5

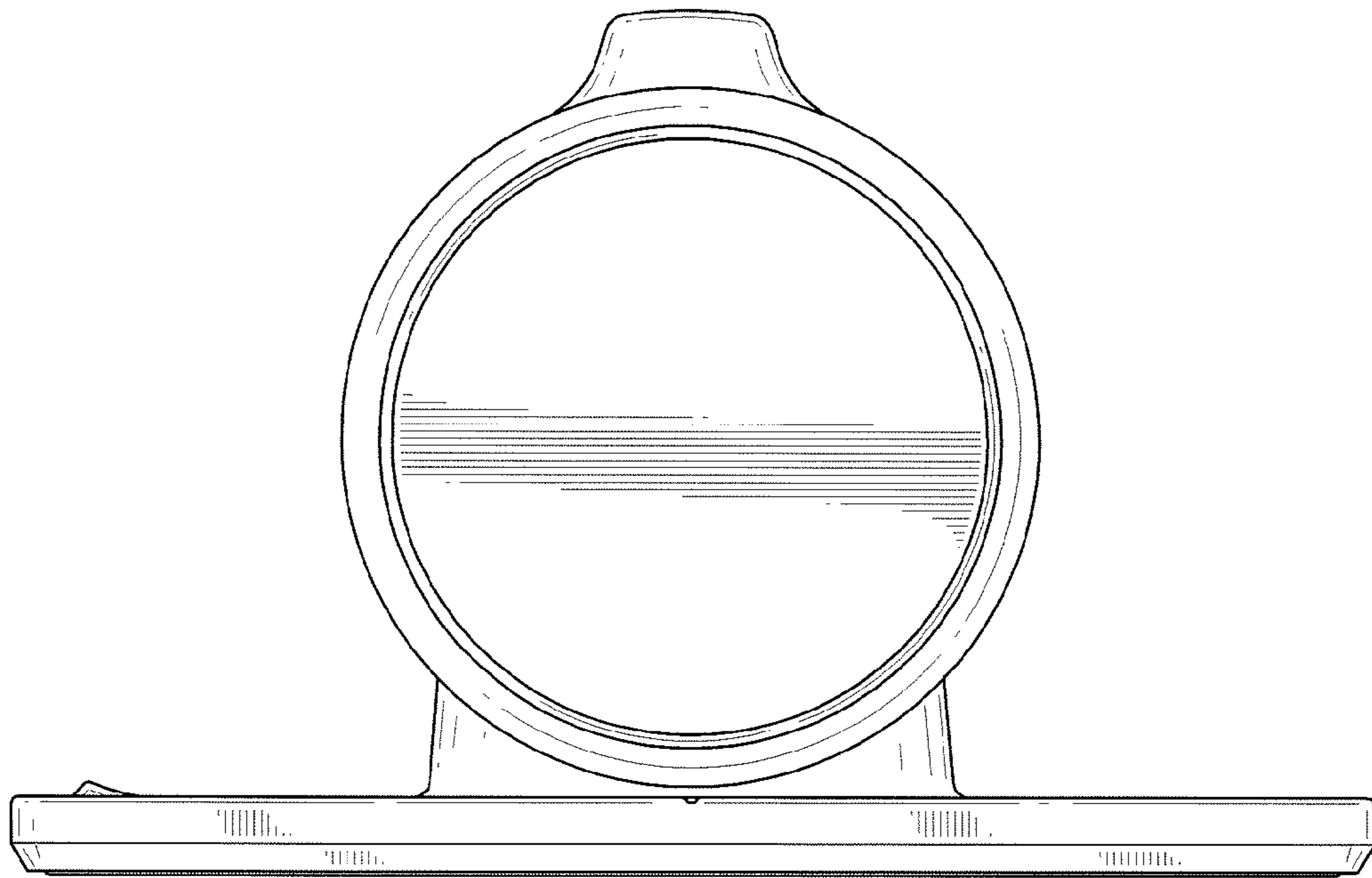

FIG. 6

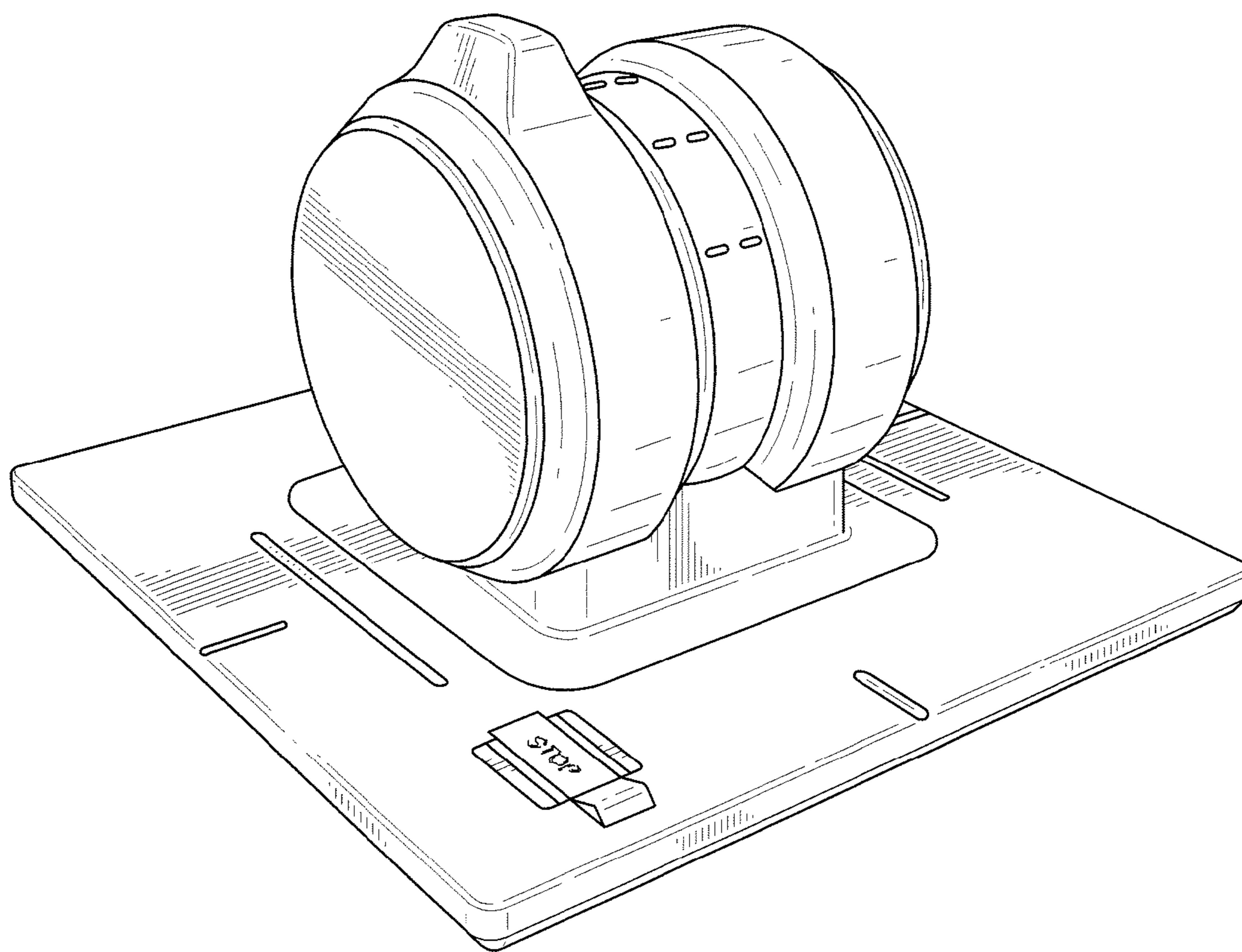

FIG. 7

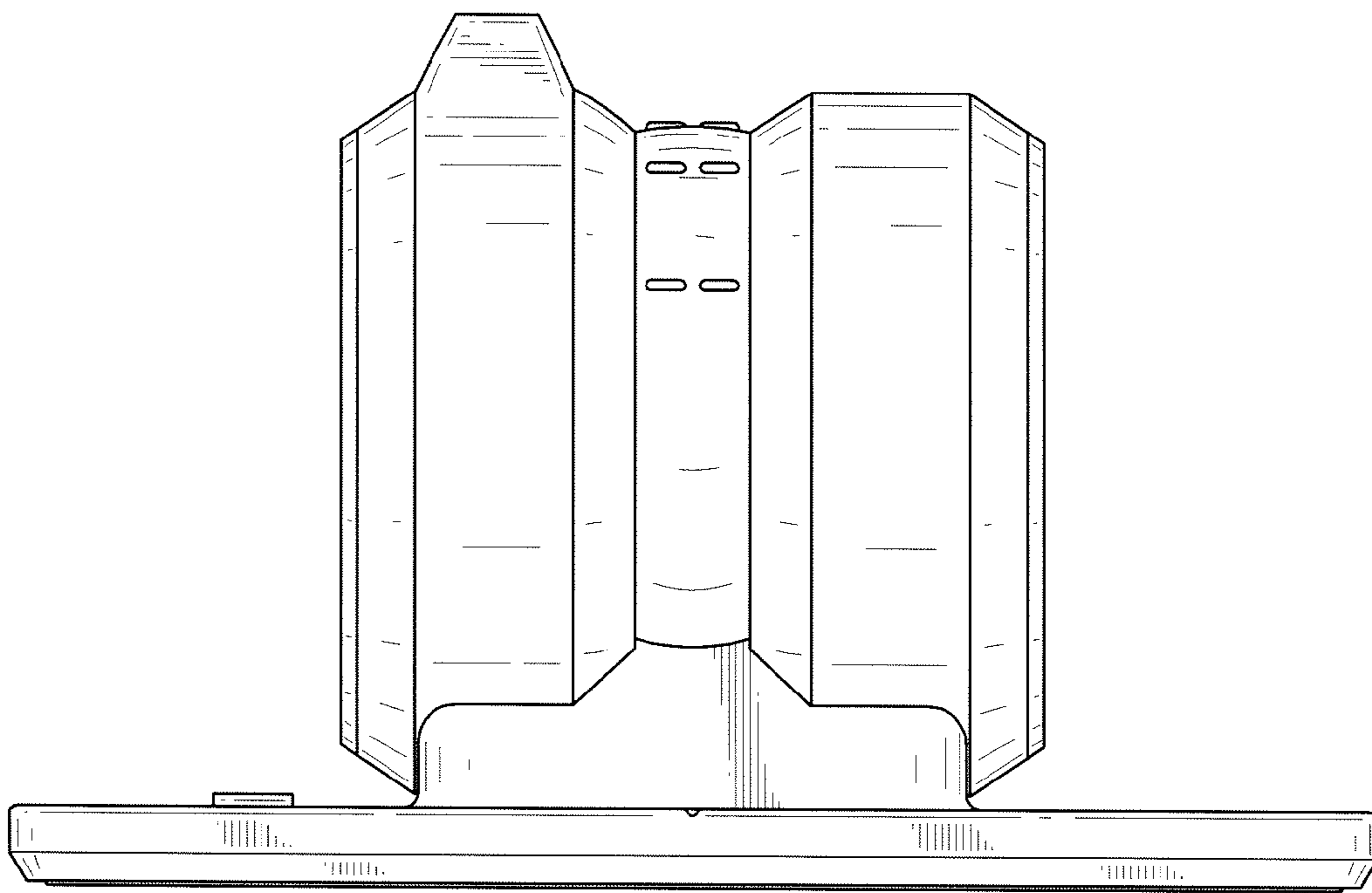

FIG. 8

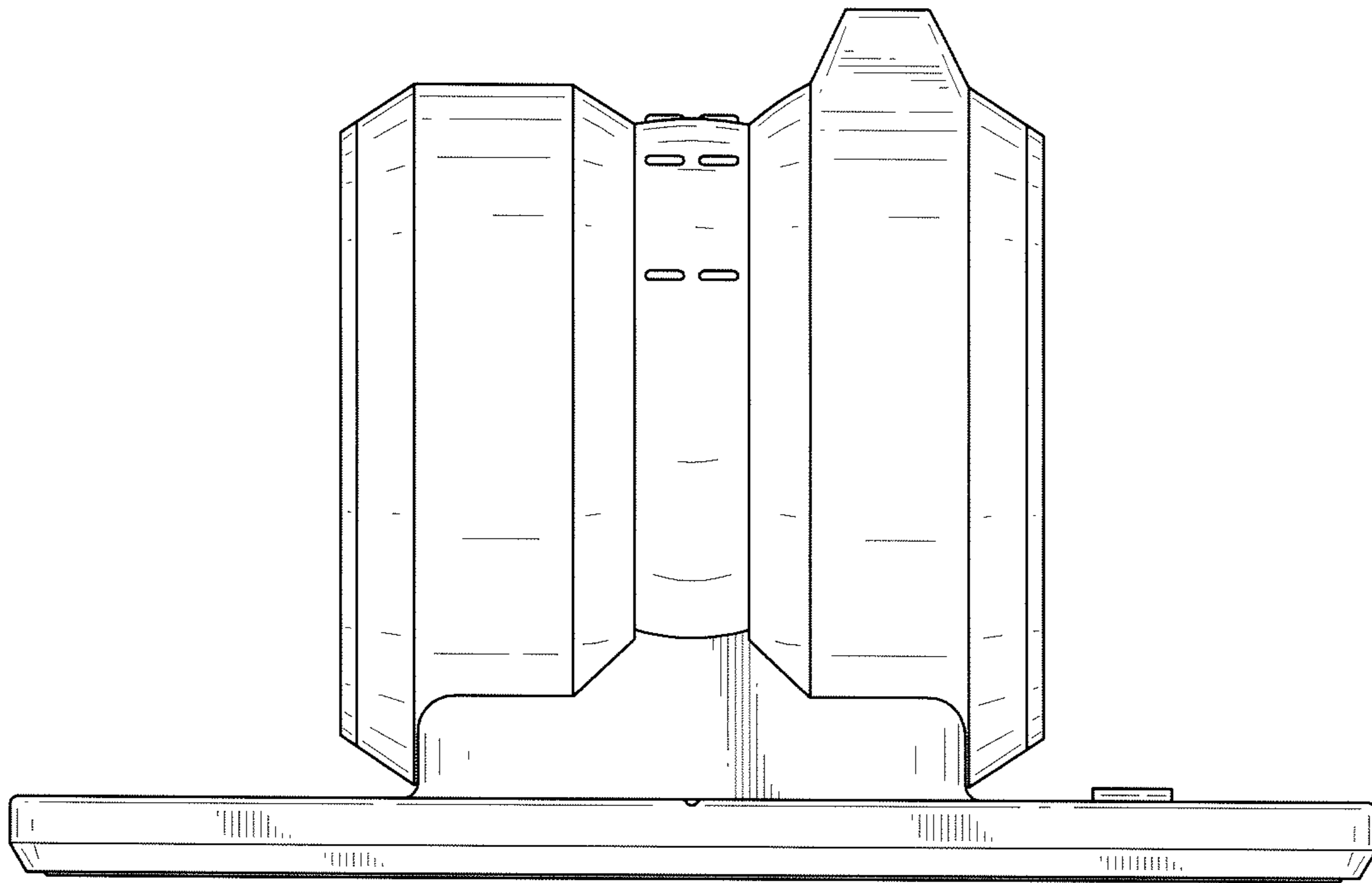

FIG. 9

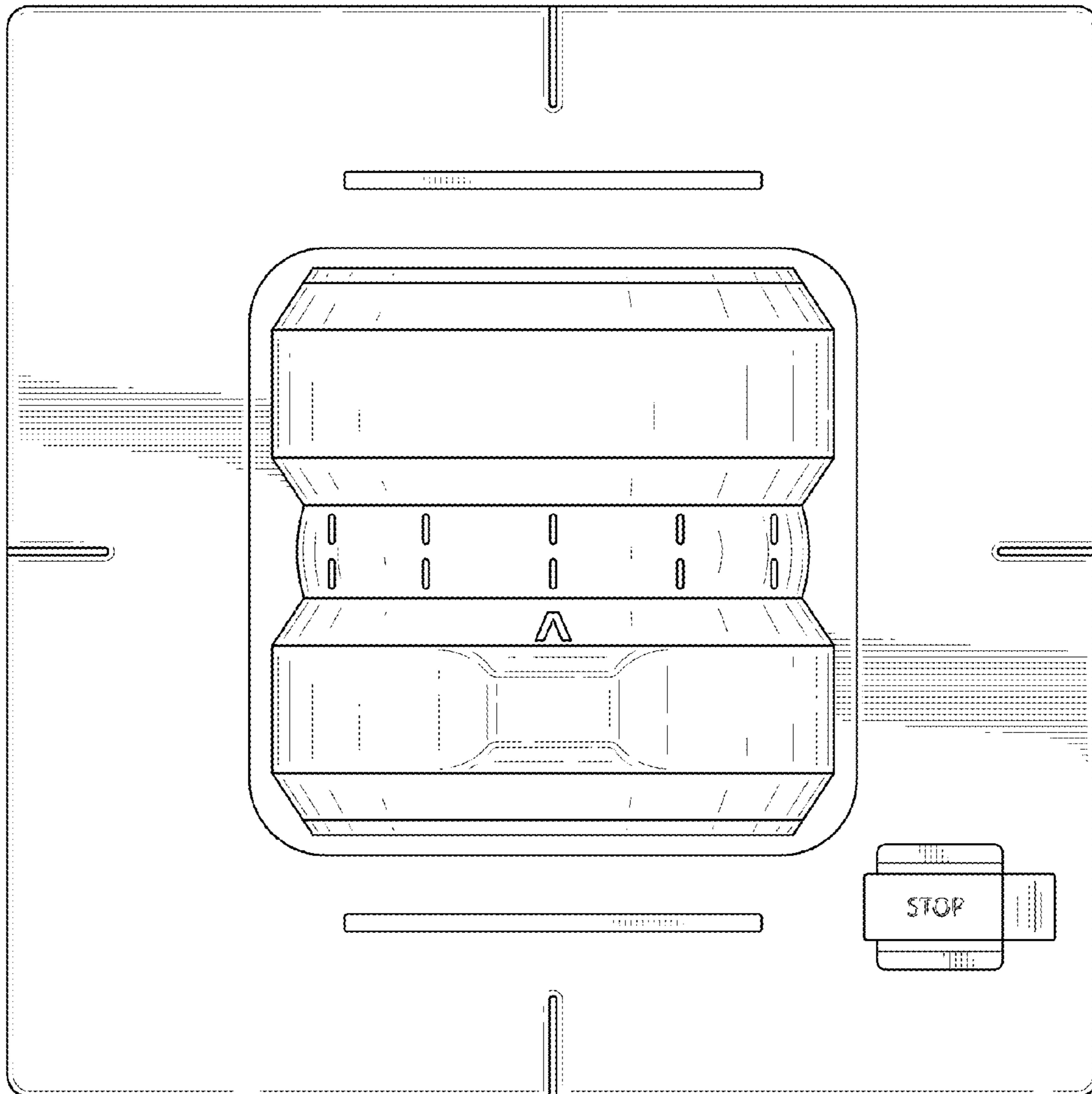

FIG.10

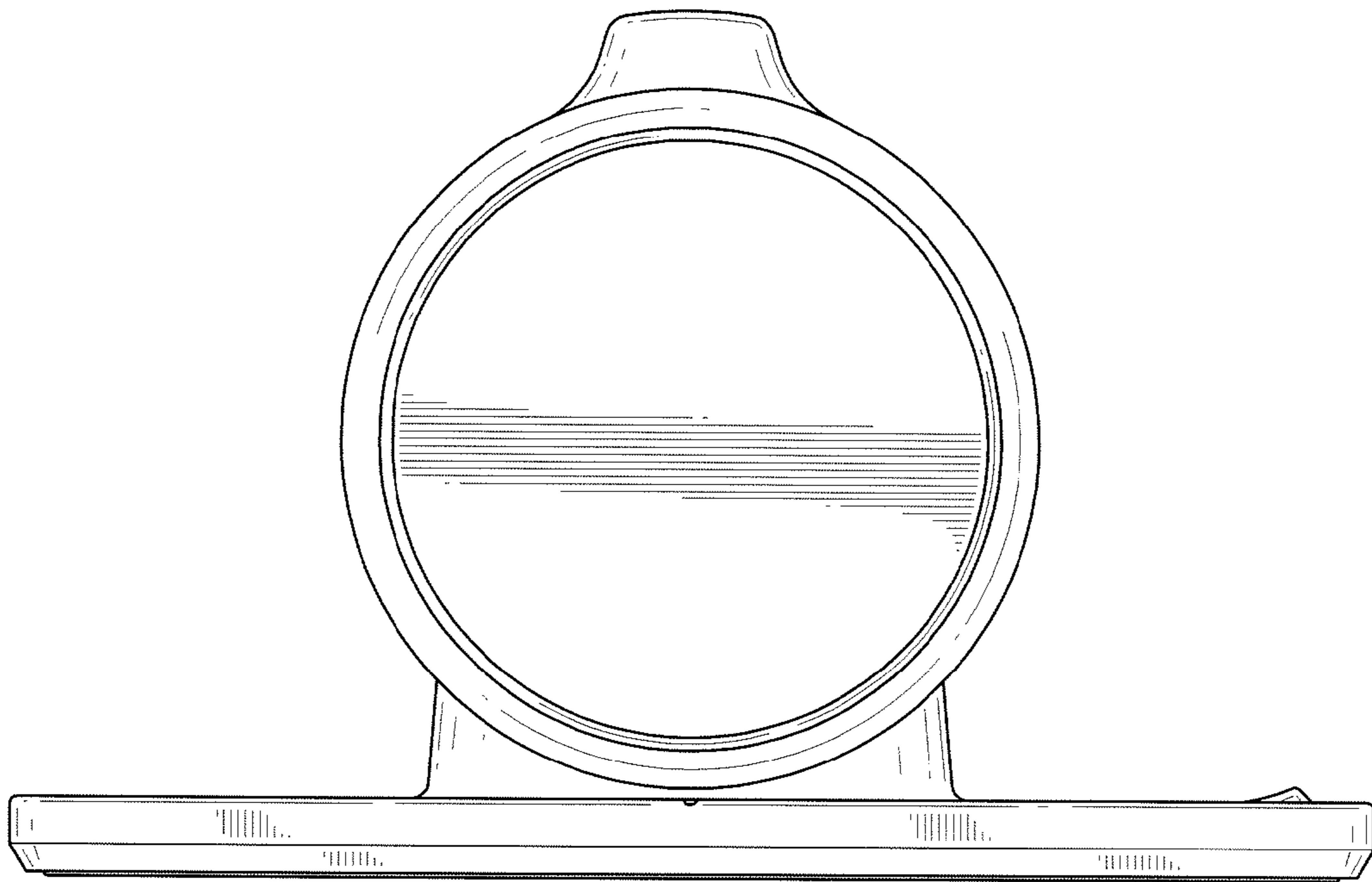

FIG. 11

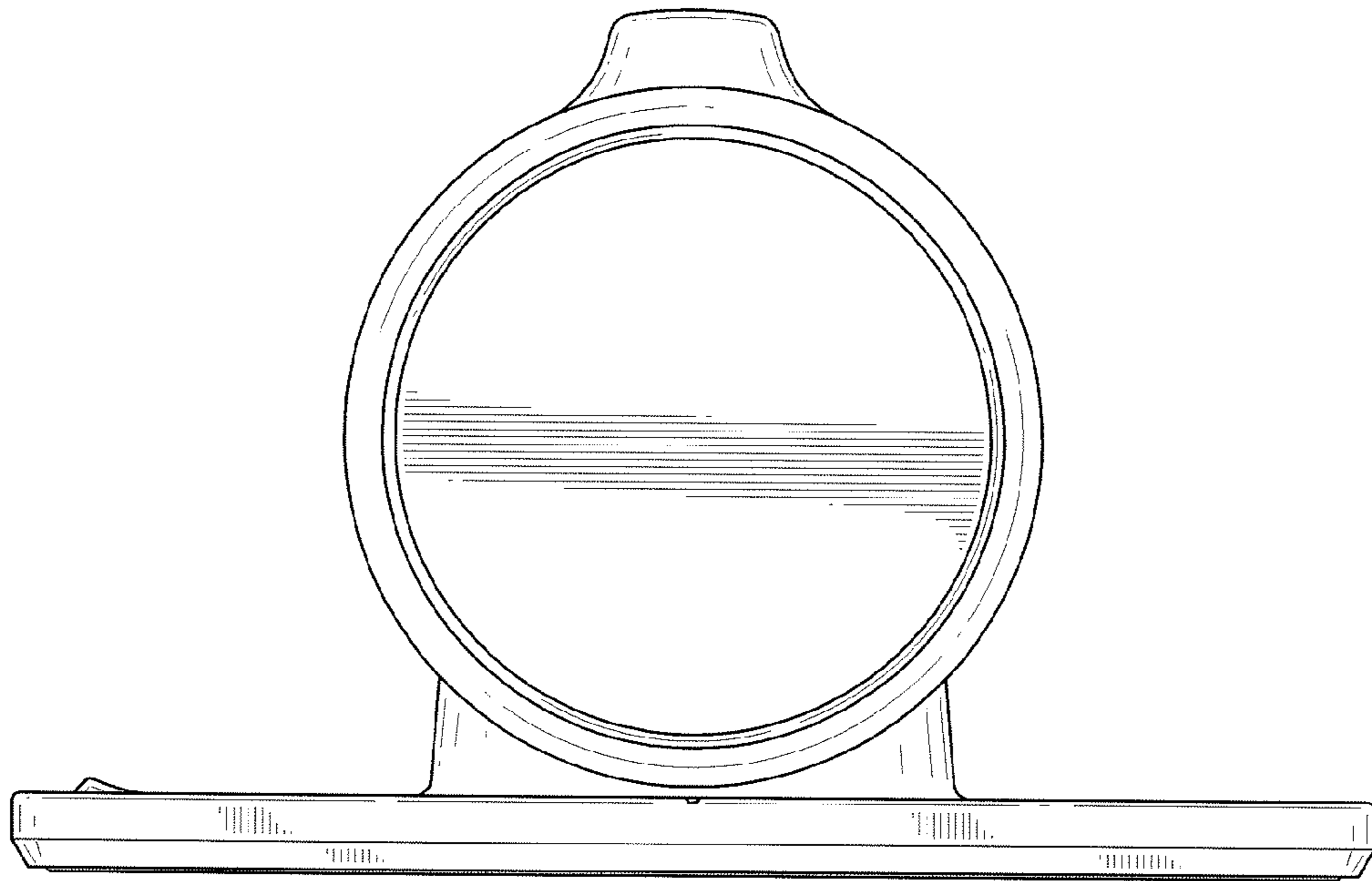

FIG. 12