

US00D755181S

(12) **United States Design Patent**
Mistkawi et al.

(10) **Patent No.:** **US D755,181 S**
(45) **Date of Patent:** **** May 3, 2016**

(54) **CODED INFORMATION READER**

(71) Applicant: **Datalogic IP Tech S.r.l.**, Lippo di Calderara di Reno (IT)

(72) Inventors: **Joseph G. Mistkawi**, Tigard, OR (US); **Stefano Vassura**, Rastignano (IT); **Maurizio Dianati**, Ferrara (IT); **Claudio Mazzone**, Crespellano (IT); **Gianluca Guzzinati**, Ferrara (IT); **Robert Rudeen**, Eugene, OR (US)

(73) Assignee: **DATALOGIC IP TECH S.R.L.**, Lippo di Calderara di Reno (BO) (IT)

(**) Term: **15 Years**

(21) Appl. No.: **29/529,046**

(22) Filed: **Jun. 3, 2015**

Related U.S. Application Data

(62) Division of application No. 29/481,459, filed on Feb. 6, 2014, now Pat. No. Des. 734,336.

(30) **Foreign Application Priority Data**

Aug. 9, 2013 (EM) 002289512

(51) **LOC (10) Cl.** **14-02**

(52) **U.S. Cl.**
USPC **D14/420**

(58) **Field of Classification Search**

USPC D14/420, 426-430, 453; 235/462.01, 235/462.11, 462.43, 462.45, 462.49, 235/472.01, 385, 454; 382/313, 321, 318; 358/473; 250/215, 216; D26/37-50, D26/24; 362/157, 158, 171-174, 183-208; 396/427

CPC G06K 7/10584; G06K 7/10613; G06K 7/10881; G06K 7/109; G06K 7/10693; G06K 7/10871; G06K 7/1096; G06K 7/10; G06K 7/10564; G06K 7/10594; G06K 7/10603; G06K 7/10663; G06K 7/10673; G06K 7/10702; G06K 7/10792; G06K 7/10633; G06K 7/10653; G06K 7/10891; G06K 7/14; G06K 7/1443; G06K 7/10801; G06K 7/10811; G06K 7/10851; G06K 7/10861; G06K 2207/1011; G06K 2207/1012; G06K 2207/1013; G06K 2207/1016; G06K

2207/1017; G06K 2207/1018; G06K 2207/10534; G06K 17/0022; A47F 9/046; A47F 9/047; G07G 1/0045; G04N 5/23238; G04N 5/2252; G04N 5/2251; G03B 17/02; B25H 5/00; B66F 7/28; G02B 26/10; G02B 26/106; G07F 11/002; G07F 11/02; G06Q 20/343; G06F 2203/0331

See application file for complete search history.

(56) **References Cited**

U.S. PATENT DOCUMENTS

5,140,141 A * 8/1992 Inagaki G06K 7/10 235/462.43

D342,245 S 12/1993 Krichever et al.

(Continued)

OTHER PUBLICATIONS

Opticon OPM2000 Scanner laser omnidirezionale product information, 2 pages, 2005.

(Continued)

Primary Examiner — Susan Moon Lee

(74) *Attorney, Agent, or Firm* — Duane Morris LLP

(57) **CLAIM**

We claim the ornamental design for a coded information reader, as shown and described.

DESCRIPTION

FIG. 1 is a perspective front view of a coded information reader according to the present invention.

FIG. 2 is a front elevation view of the coded information reader of FIG. 1.

FIG. 3 is a rear elevation view of the coded information reader of FIG. 1.

FIG. 4 is a top view of the coded information reader of FIG. 1.

FIG. 5 is a right side elevation view of the coded information reader of FIG. 1; and,

FIG. 6 is a left side elevation view of the coded information reader of FIG. 1.

The bottom of the coded information reader of FIG. 1 is flat and devoid of surface ornamentation.

Broken lines and unshaded portions contained within broken lines are not claimed.

1 Claim, 6 Drawing Sheets

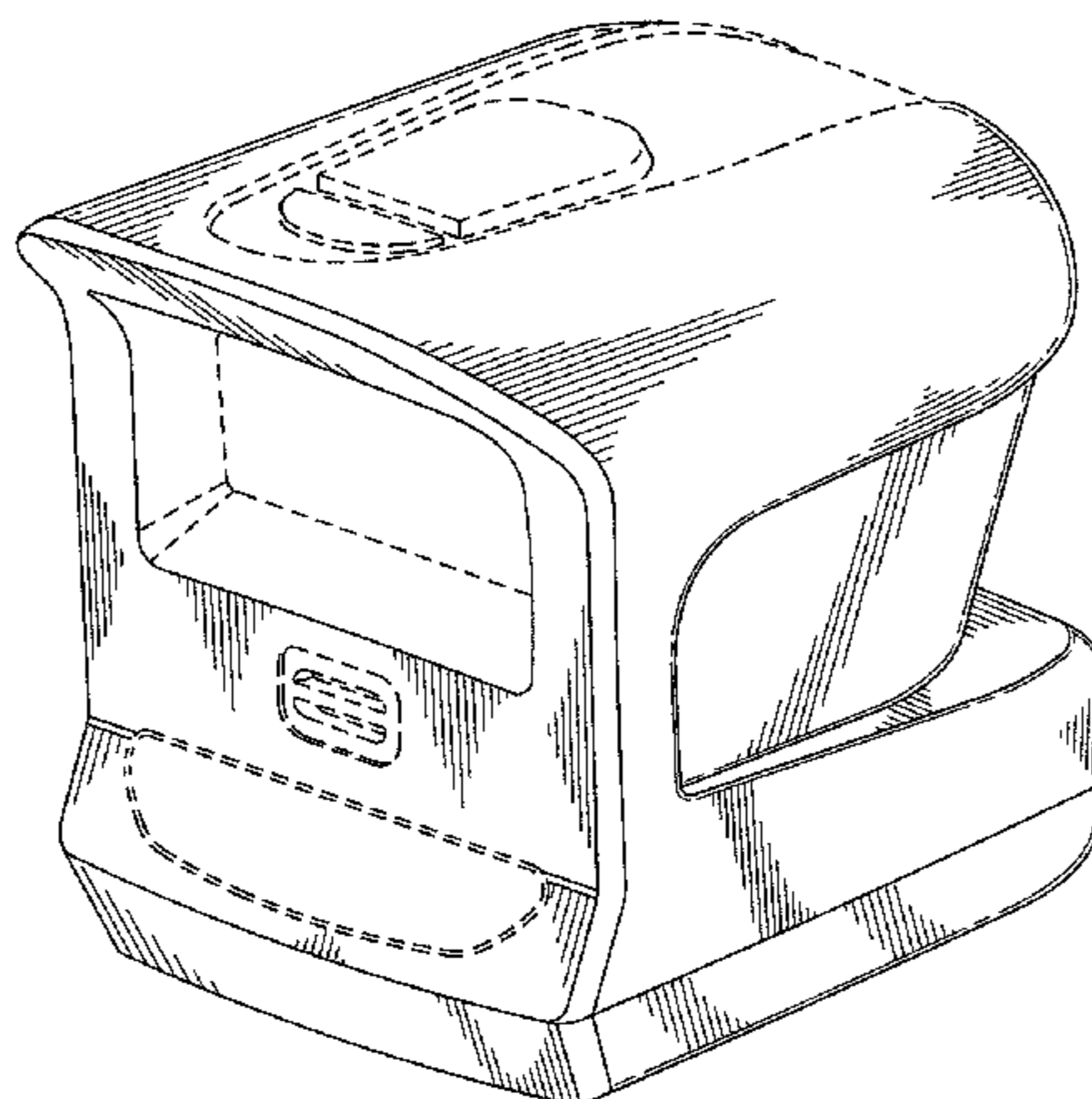

(56)

References Cited

U.S. PATENT DOCUMENTS

5,340,972 A 8/1994 Sandor
 D350,735 S 9/1994 Karlin et al.
 D352,938 S 11/1994 Karlin
 D359,483 S 6/1995 Saunders et al.
 5,550,366 A 8/1996 Roustaei
 5,610,386 A 3/1997 Ball et al.
 D391,250 S 2/1998 Swift et al.
 5,808,289 A 9/1998 Becker
 D408,806 S 4/1999 Schmidt et al.
 6,065,676 A * 5/2000 Ring G06K 7/10871
 235/462.32
 6,216,953 B1 4/2001 Kumagai et al.
 D453,514 S 2/2002 Elam et al.
 D454,879 S 3/2002 Lin et al.
 D462,688 S 9/2002 Schieffers et al.
 D462,964 S 9/2002 Croley et al.
 6,554,765 B1 4/2003 Yarush et al.
 6,749,121 B2 6/2004 Connolly et al.
 6,778,087 B2 8/2004 Belka et al.
 7,195,162 B2 * 3/2007 Mazzone G06K 7/10881
 235/454
 D554,641 S 11/2007 Miller et al.
 D566,712 S 4/2008 Ah
 D580,939 S 11/2008 Fitch et al.
 D585,066 S 1/2009 Morris et al.
 7,527,207 B2 * 5/2009 Acosta G06K 7/10732
 235/462.17
 D612,853 S 3/2010 Waterman
 8,196,787 B2 6/2012 Strandberg et al.
 8,235,294 B2 8/2012 Miller et al.

8,366,005 B2 2/2013 Kotlarsky et al.
 8,408,468 B2 4/2013 Van Horn et al.
 D734,336 S * 7/2015 Mistkawi D14/420
 2004/0149829 A1 8/2004 Boucher et al.
 2006/0081712 A1 4/2006 Rudeen et al.
 2008/0078838 A1 4/2008 Morris et al.
 2008/0314985 A1 12/2008 Kotlarsky et al.
 2010/0019040 A1 1/2010 Haber et al.
 2011/0017828 A1 1/2011 Pine
 2011/0132984 A1 6/2011 Fletcher
 2012/0018516 A1 1/2012 Gao et al.
 2012/0049052 A1 3/2012 Handshaw et al.
 2012/0085824 A1 4/2012 Handshaw et al.
 2012/0111945 A1 5/2012 Kearney
 2013/0038985 A1 2/2013 Powell et al.
 2013/0194451 A1 8/2013 Zhu et al.

OTHER PUBLICATIONS

Datalogic Magellan™ 800i on Counter Presentation
 Omnidirectional Bar Code Reader Quick Reference Guide, Oct.
 2013, 24 pages (© 2011-2013).
 Datalogic Magellan™ 1100i Omni-Directional Imaging Scanner
 Quick Reference Guide, Oct. 2013, 48 pages (© 2009-2013).
 Datalogic Magellan™ 1400i Omni-Directional Imaging Scanner
 Quick Reference Guide, Jan. 2012, 12 pages (© 2007-2012).
 Datalogic Magellan™ 2200VS Quick Reference Guide, May 2013,
 52 pages (© 2002-2013).
 Datalogic Magellan™ 3200VSi Omni-Directional Imaging Scanner,
 Jun. 2013, 28 pages (© 2010-2013).

* cited by examiner

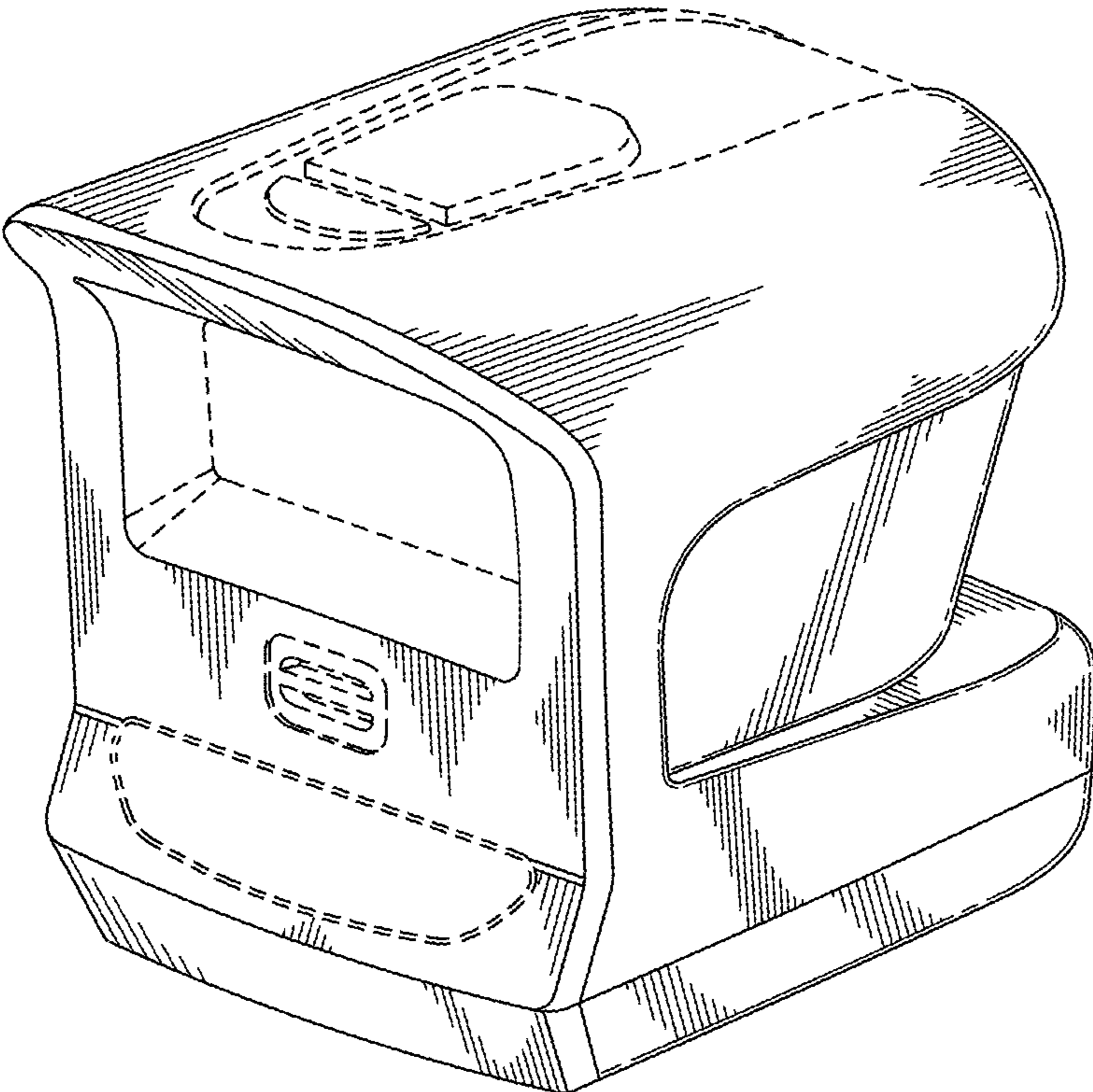

FIG. 1

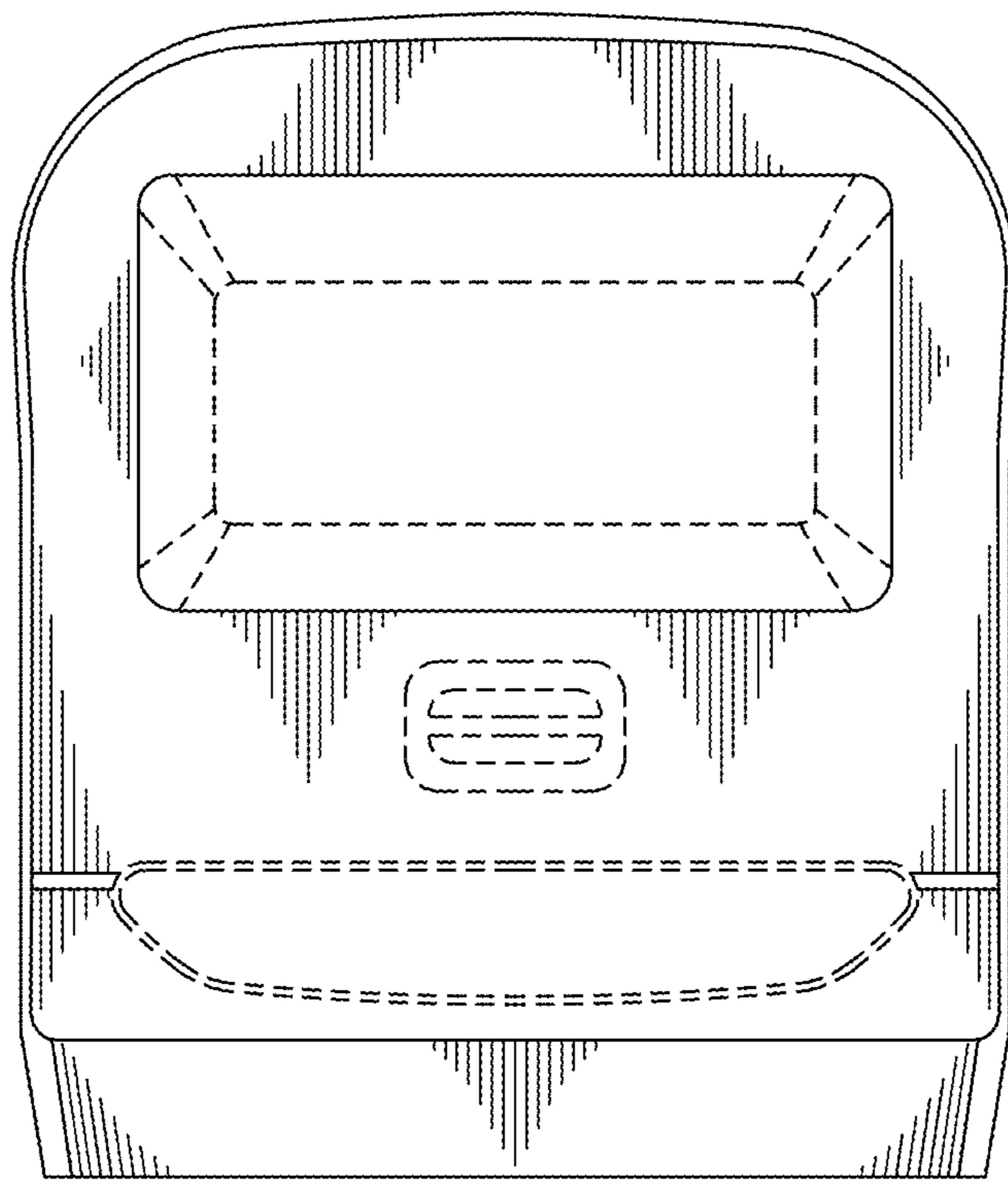

FIG. 2

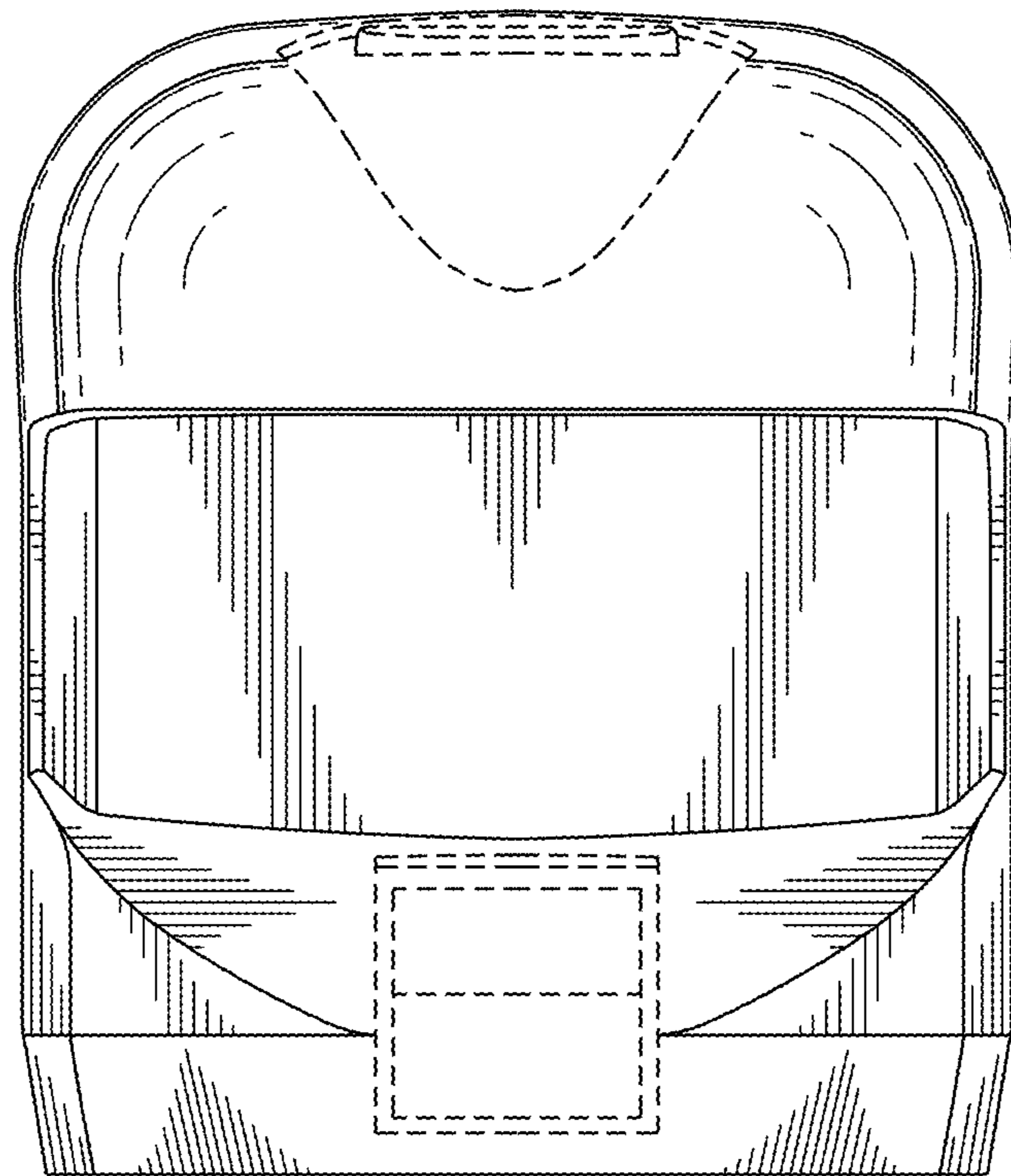

FIG. 3

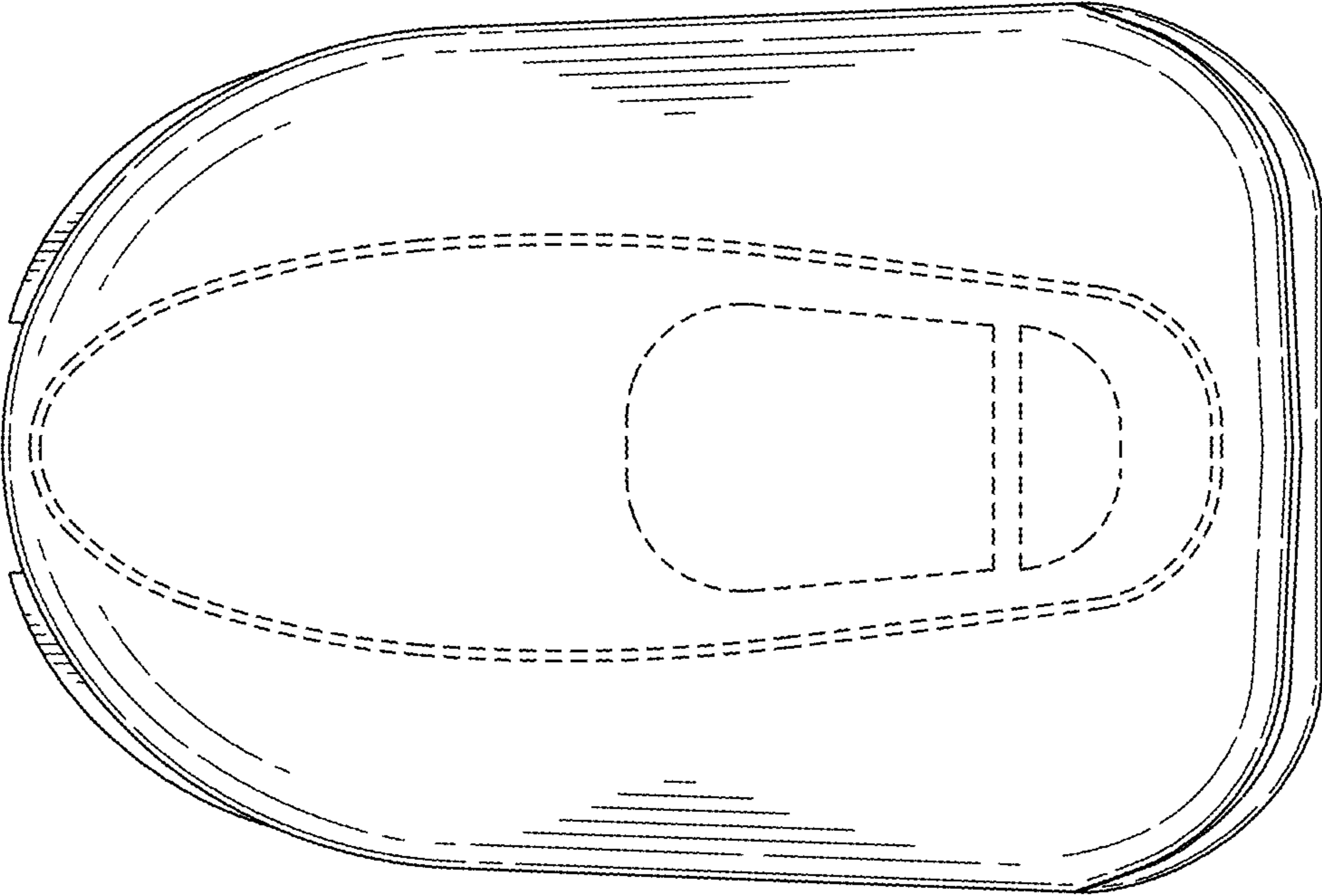

FIG. 4

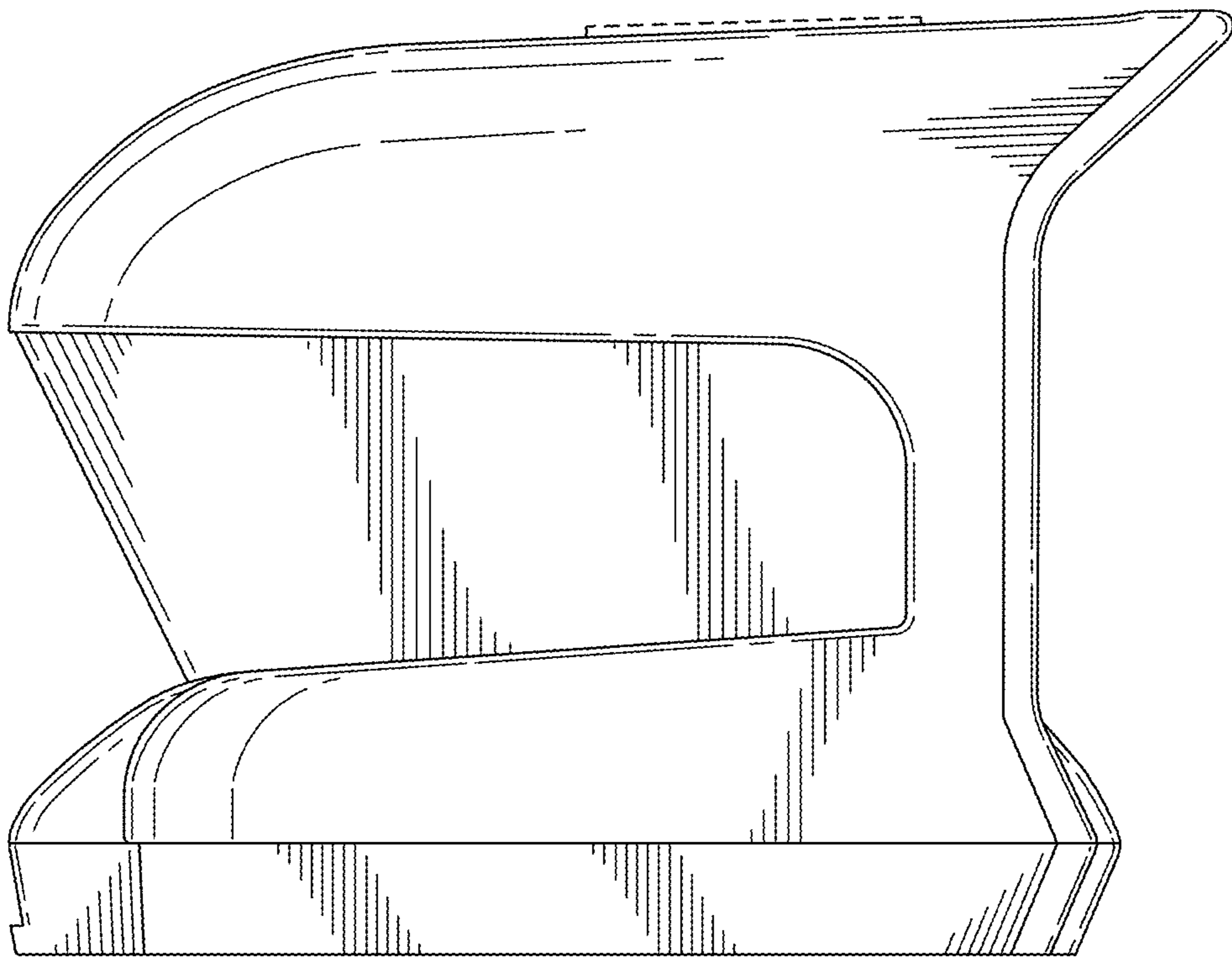

FIG. 5

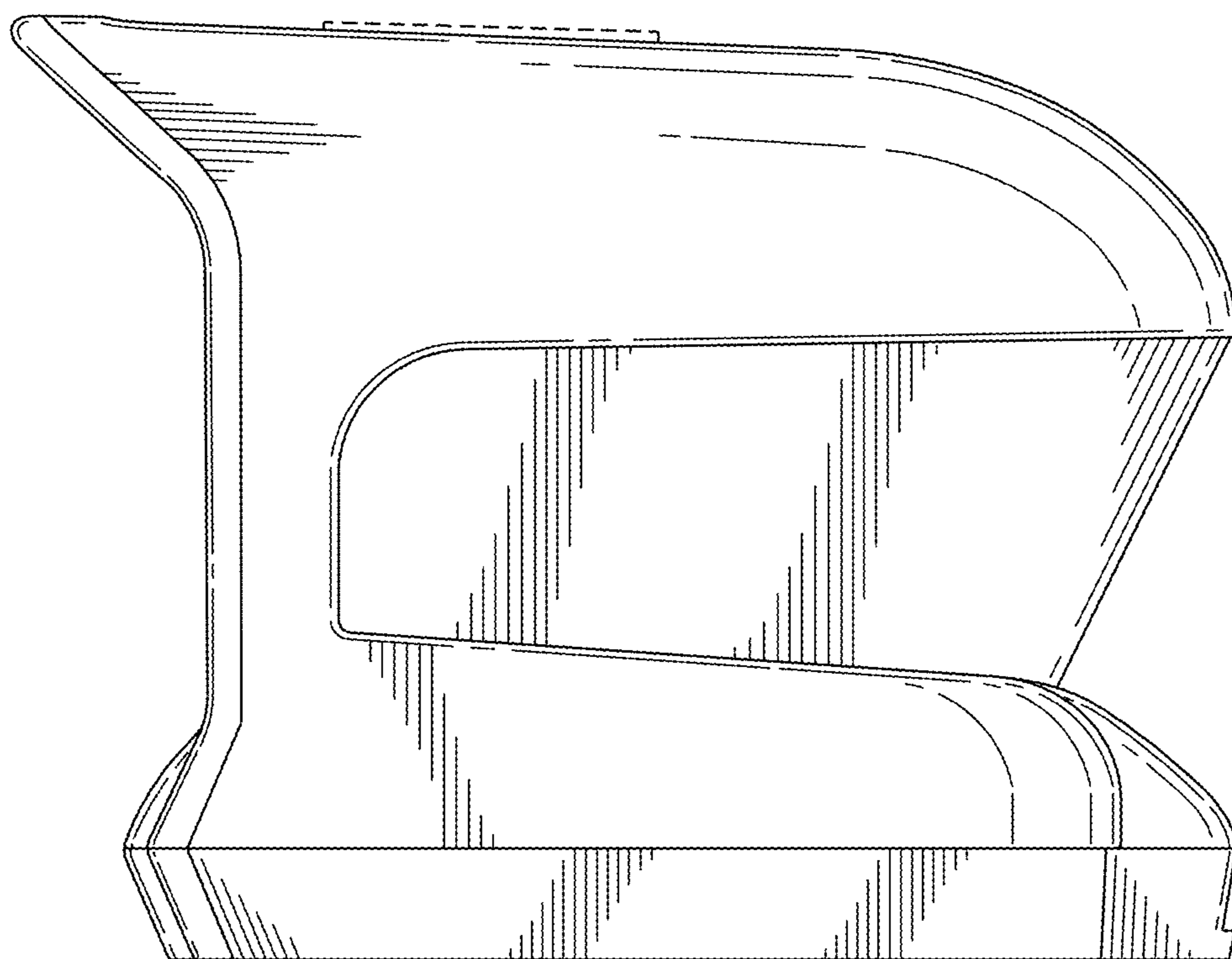

FIG. 6