



US00D754992S

(12) **United States Design Patent**  
**Brown et al.**

(10) **Patent No.:** **US D754,992 S**  
(45) **Date of Patent:** **\*\* May 3, 2016**

(54) **DEVICE FOR HANDLING AN AUTOMOTIVE TOP**

(71) Applicants: **Hugh Brown**, Oxford, MS (US); **Tatum Brown**, Oxford, MS (US)

(72) Inventors: **Hugh Brown**, Oxford, MS (US); **Tatum Brown**, Oxford, MS (US)

(\*\*) Term: **14 Years**

(21) Appl. No.: **29/525,931**

(22) Filed: **May 5, 2015**

(51) **LOC (10) Cl.** ..... **06-06**

(52) **U.S. Cl.**  
USPC ..... **D6/675**

(58) **Field of Classification Search**  
USPC ..... D6/672, 673, 675, 678, 680.2, 681;  
D12/400, 406, 423-424  
CPC ... A47F 5/0018; B65D 21/00; B65D 81/3813  
See application file for complete search history.

(56) **References Cited**

**U.S. PATENT DOCUMENTS**

D232,812 S *	9/1974	Ogle et al.	.....	D11/155
3,946,876 A *	3/1976	Jay	.....	B65D 19/08 108/55.1
4,247,009 A *	1/1981	Vaurigaud	.....	F16L 3/233 21/60.1
4,295,431 A *	10/1981	Stavlo	.....	B65D 19/08 108/55.1
D296,279 S *	6/1988	Baldree	.....	D6/675
D296,503 S *	7/1988	Bell	.....	D6/675

5,078,415 A *	1/1992	Goral	.....	B62B 3/104 108/55.1
D331,674 S *	12/1992	Leis	.....	D6/681.1
D334,496 S *	4/1993	Schnair	.....	D3/272
D343,042 S *	1/1994	Apps	.....	D3/314
D379,882 S *	6/1997	Tomasino	.....	D6/661
D437,710 S *	2/2001	Guerra	.....	D6/675
D462,541 S *	9/2002	Welch	.....	D6/675
D467,449 S *	12/2002	Ong	.....	D6/675
D467,450 S *	12/2002	Trulaske, Sr.	.....	D15/81
2015/0368052 A1 *	12/2015	Sheesley	.....	B65G 65/40 414/414
2016/0025461 A1 *	1/2016	Roberts	.....	F41H 7/04 296/187.07

\* cited by examiner

*Primary Examiner* — Kelley Donnelly

(74) *Attorney, Agent, or Firm* — Harris, Shelton, Hanover & Walsh; Susan B. Fentress

(57) **CLAIM**

The ornamental design for a device for handling an automotive top, substantially as shown and described.

**DESCRIPTION**

FIG. 1 is an isometric front view showing our new design; FIG. 2 is a front view showing our new design; FIG. 3 is a right side elevational view showing our new design, the left view being identical; FIG. 4 is a rear view showing our new design; FIG. 5 is a top view showing our new design; and, FIG. 6 is a bottom view showing our new design. Any broken lines shown in the drawings are for illustrative purposes only and form no part of the claimed design.

**1 Claim, 4 Drawing Sheets**

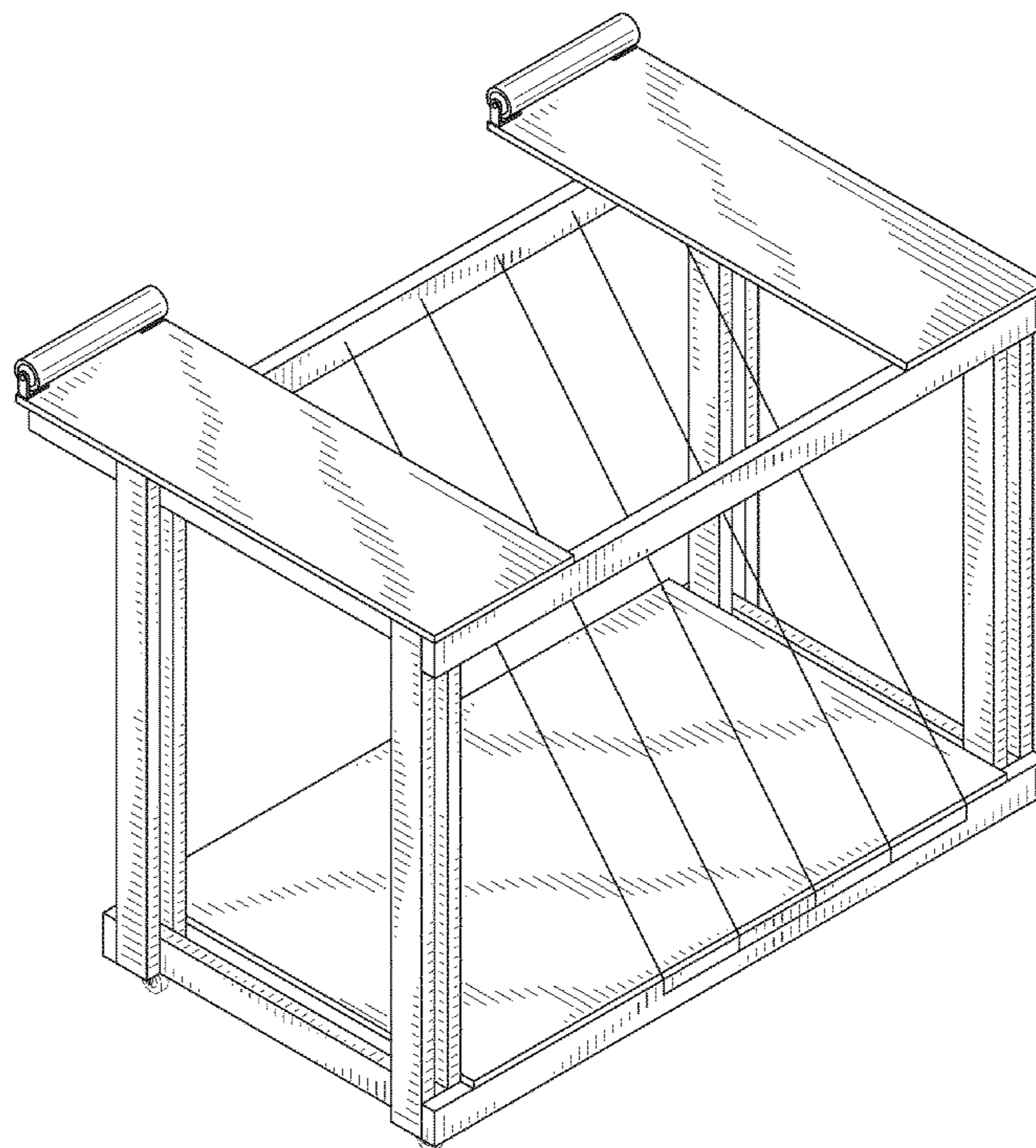

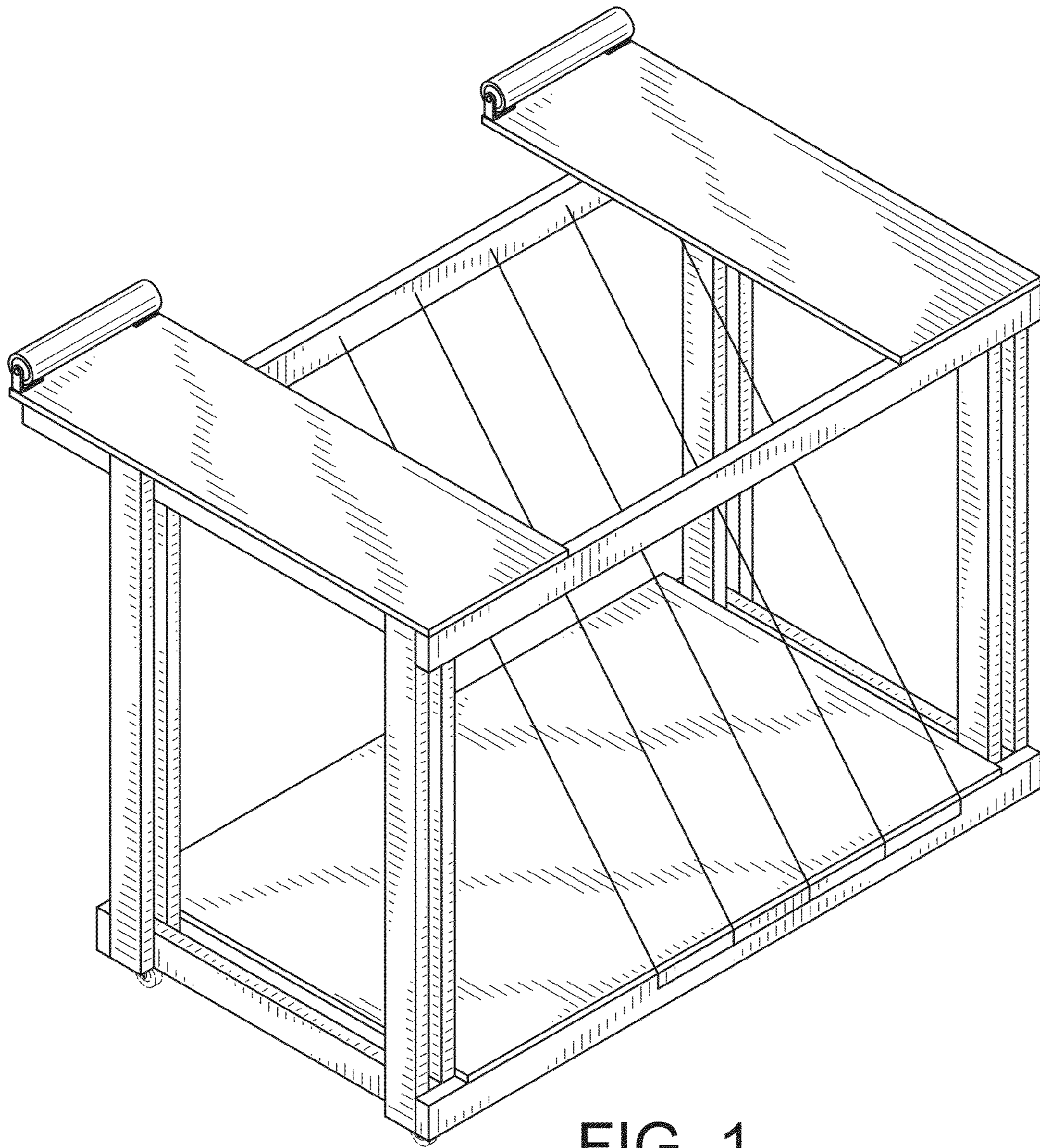

FIG. 1



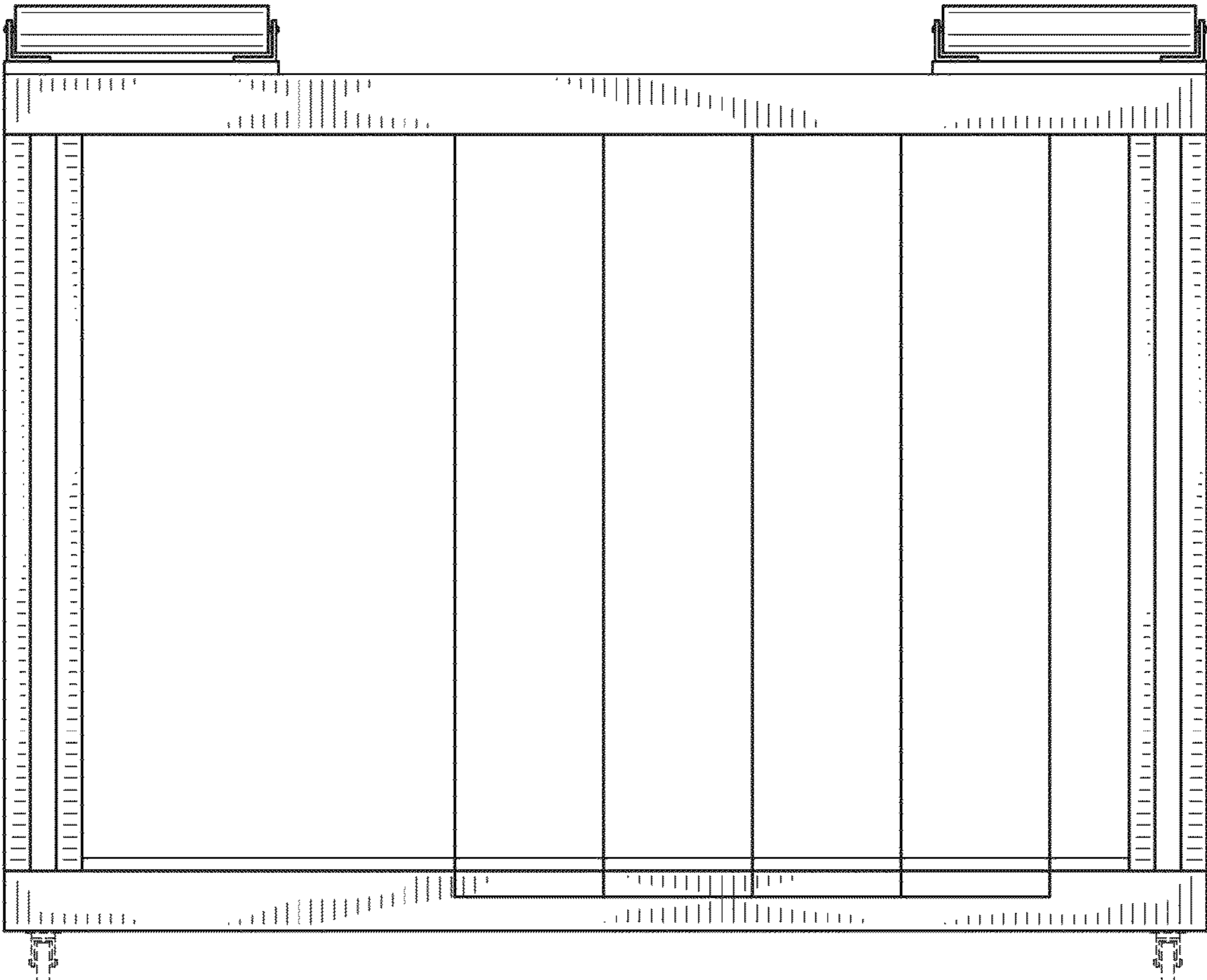

FIG. 2

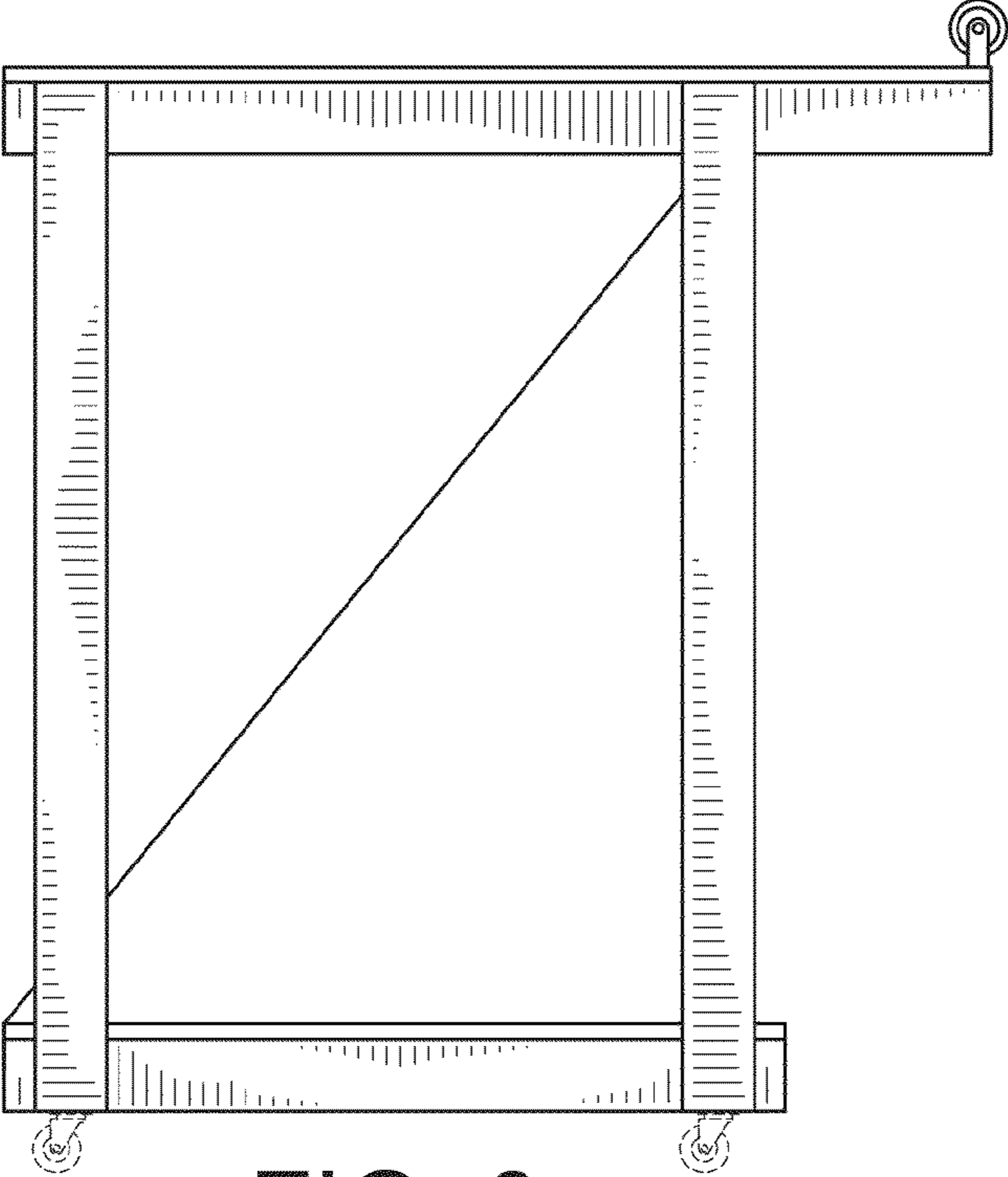

FIG. 3

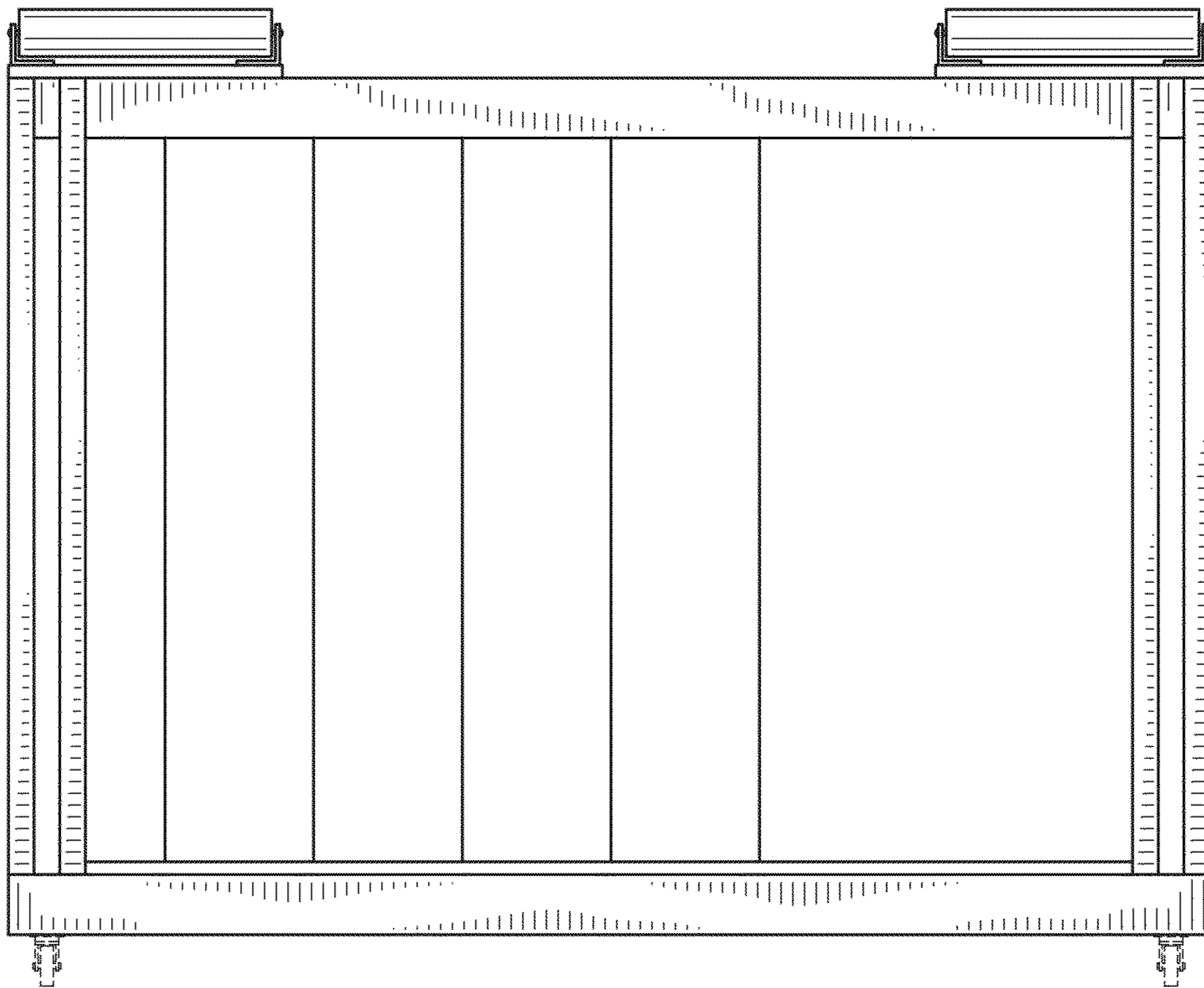

FIG. 4

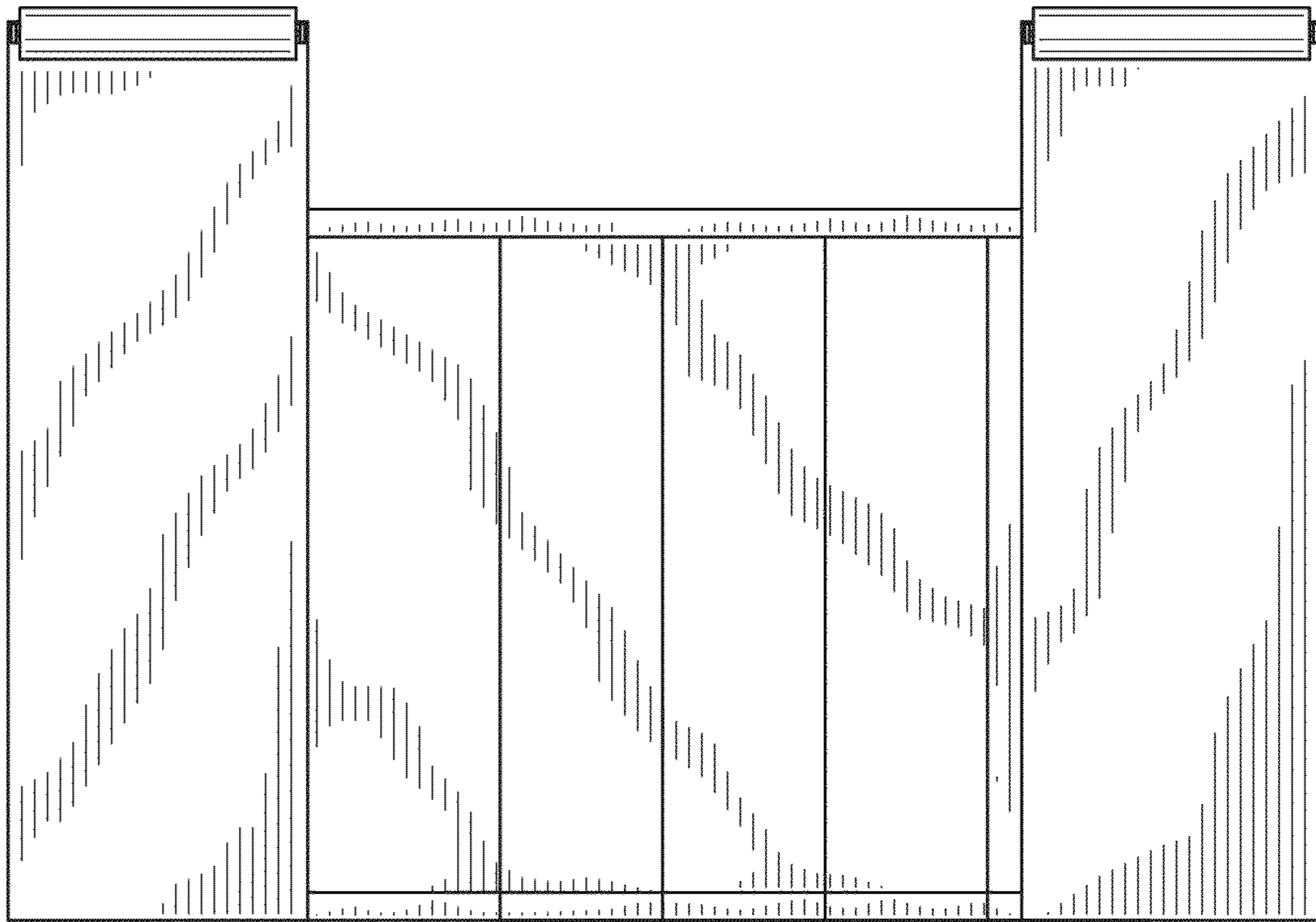

FIG. 5

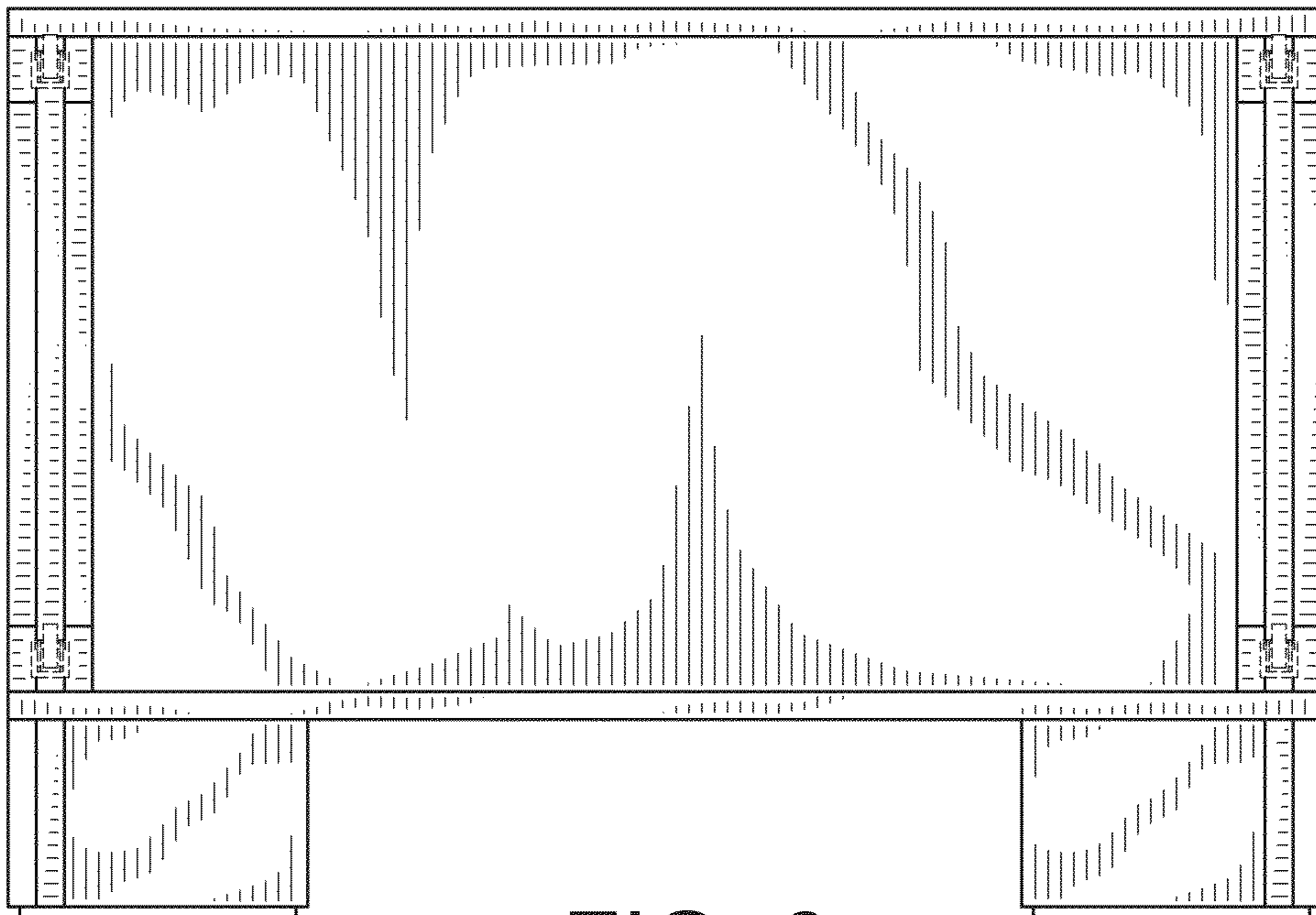

FIG. 6