



US00D754753S

(12) **United States Design Patent**  
**Kiyoyuki et al.**

(10) **Patent No.:** **US D754,753 S**  
(45) **Date of Patent:** **\*\* Apr. 26, 2016**

(54) **MARINE ENGINE**  
(71) Applicant: **Yanmar Co., Ltd.**, Osaka-shi, Osaka (JP)  
(72) Inventors: **Okuyama Kiyoyuki**, Yamagata (JP); **Nakanishi Takao**, Osaka (JP); **Maetani Kazuki**, Osaka (JP)  
(73) Assignee: **YANMAR CO., LTD.**, Osaka (JP)  
(\*\*) Term: **14 Years**  
(21) Appl. No.: **29/494,391**  
(22) Filed: **Jun. 19, 2014**

D510,720 S \* 10/2005 Kruse ..... D12/317  
D512,438 S \* 12/2005 Matsunami ..... D15/5  
7,390,232 B1 \* 6/2008 English ..... B63H 21/32  
440/89 B  
D626,969 S \* 11/2010 Gelardi ..... D15/5  
D733,763 S \* 7/2015 Nuta ..... D15/1  
D735,757 S \* 8/2015 Nuta ..... D15/1  
2002/0151229 A1 \* 10/2002 Kanno ..... F01M 1/24  
440/1  
2011/0100320 A1 \* 5/2011 Ernst ..... F02B 77/02  
123/198 E  
2014/0202136 A1 \* 7/2014 Sprute ..... F01N 3/106  
60/274  
2015/0053185 A1 \* 2/2015 Hibino ..... F02B 29/04  
123/568.12

\* cited by examiner

*Primary Examiner* — T. Chase Nelson  
*Assistant Examiner* — Ania Aman  
(74) *Attorney, Agent, or Firm* — Sterne, Kessler, Goldstein & Fox P.L.L.C.

(30) **Foreign Application Priority Data**  
Dec. 20, 2013 (JP) ..... 2013-030030  
(51) **LOC (10) Cl.** ..... **15-01**  
(52) **U.S. Cl.**  
USPC ..... **D15/4; D15/5**  
(58) **Field of Classification Search**  
USPC ..... D15/1-6, 14, 17, 149; D13/184;  
123/22, 41, 51 A, 34, 606 R, 52.1, 50 A,  
123/50 B, 54.1, 54.2, 54.4, 54.5, 65 R,  
123/195 R, 195 HC, 657, 311, 635, 195 C,  
123/903.38, 568.12, 90.38  
CPC ..... F01M 5/00; F16M 1/026; F02P 3/02;  
F02B 37/013  
See application file for complete search history.

(56) **References Cited**  
U.S. PATENT DOCUMENTS  
6,571,753 B1 \* 6/2003 Jaeger ..... F01P 11/0276  
123/41.14  
6,644,024 B1 \* 11/2003 Powers ..... F01N 3/04  
60/298

(57) **CLAIM**  
The ornamental design for a marine engine, as shown and described.

**DESCRIPTION**

FIG. 1 is a perspective view of a marine engine showing our new design;  
FIG. 2 is a top plan view thereof;  
FIG. 3 is a front view thereof;  
FIG. 4 is a right side view thereof;  
FIG. 5 is a left side view thereof; and,  
FIG. 6 is a rear view thereof.  
The broken lines shown in the drawings are for the purpose of illustrating environment and form no part of the claimed design.

**1 Claim, 3 Drawing Sheets**

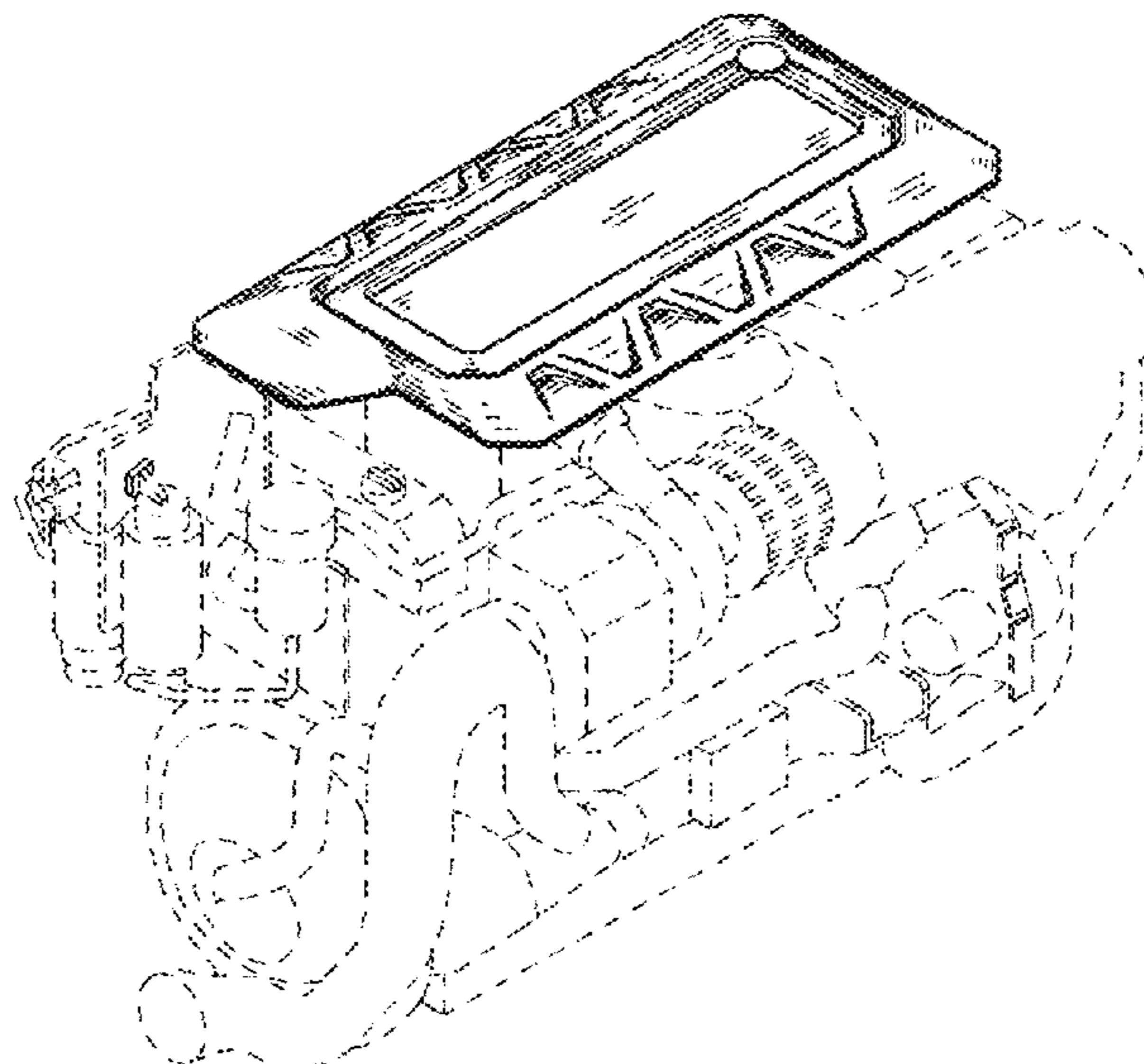

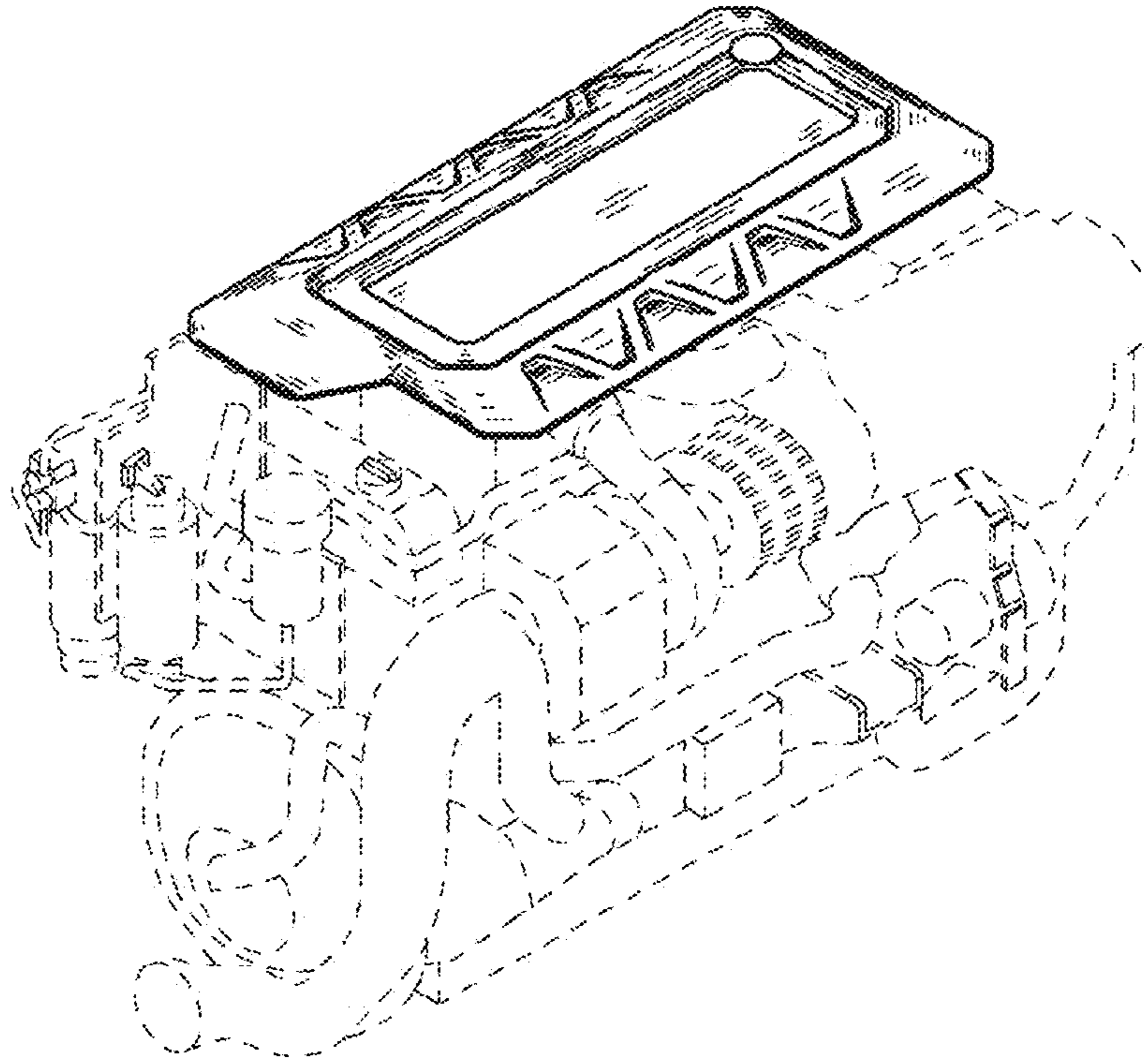

FIG. 1

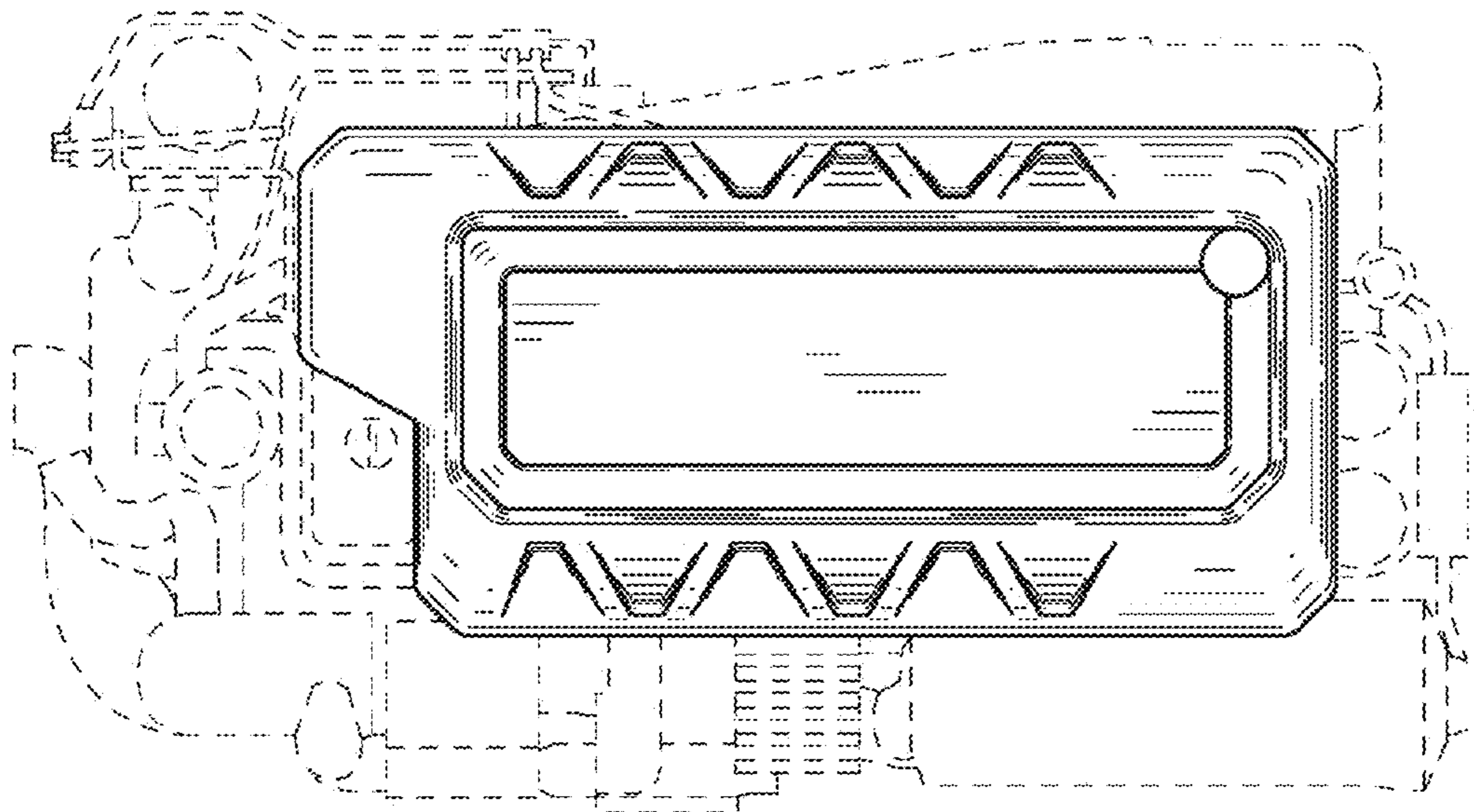

FIG. 2

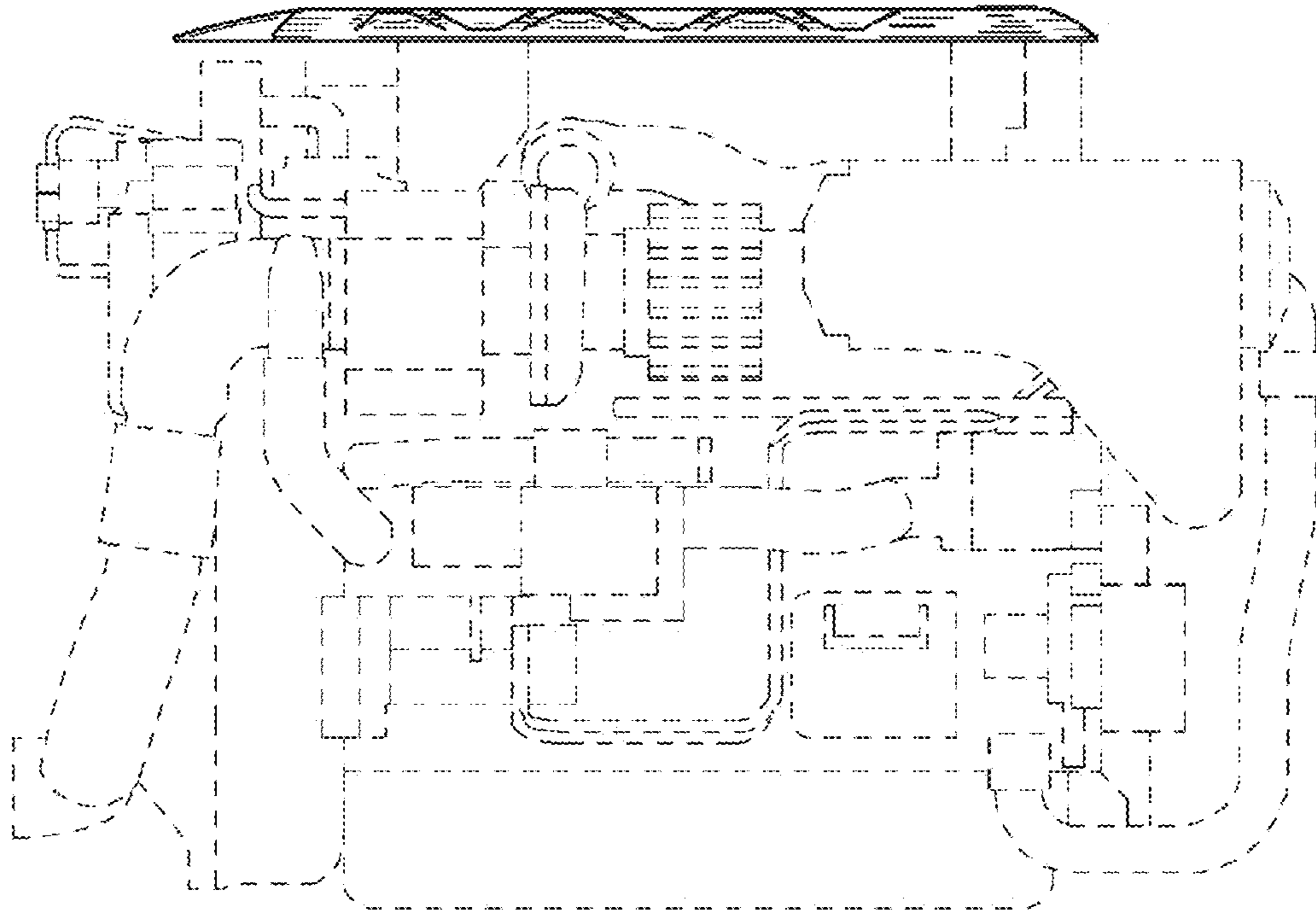

FIG. 3

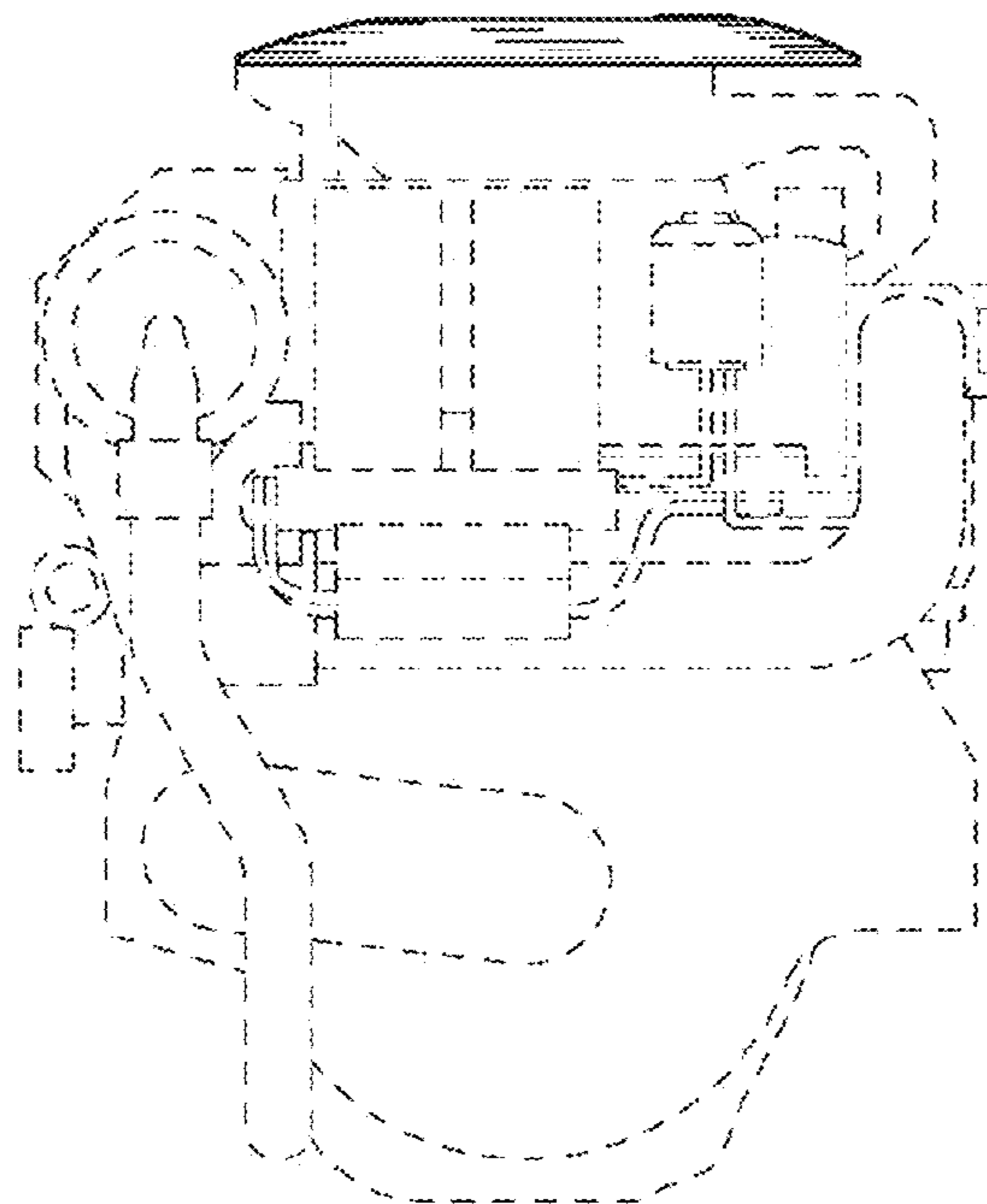

FIG. 4



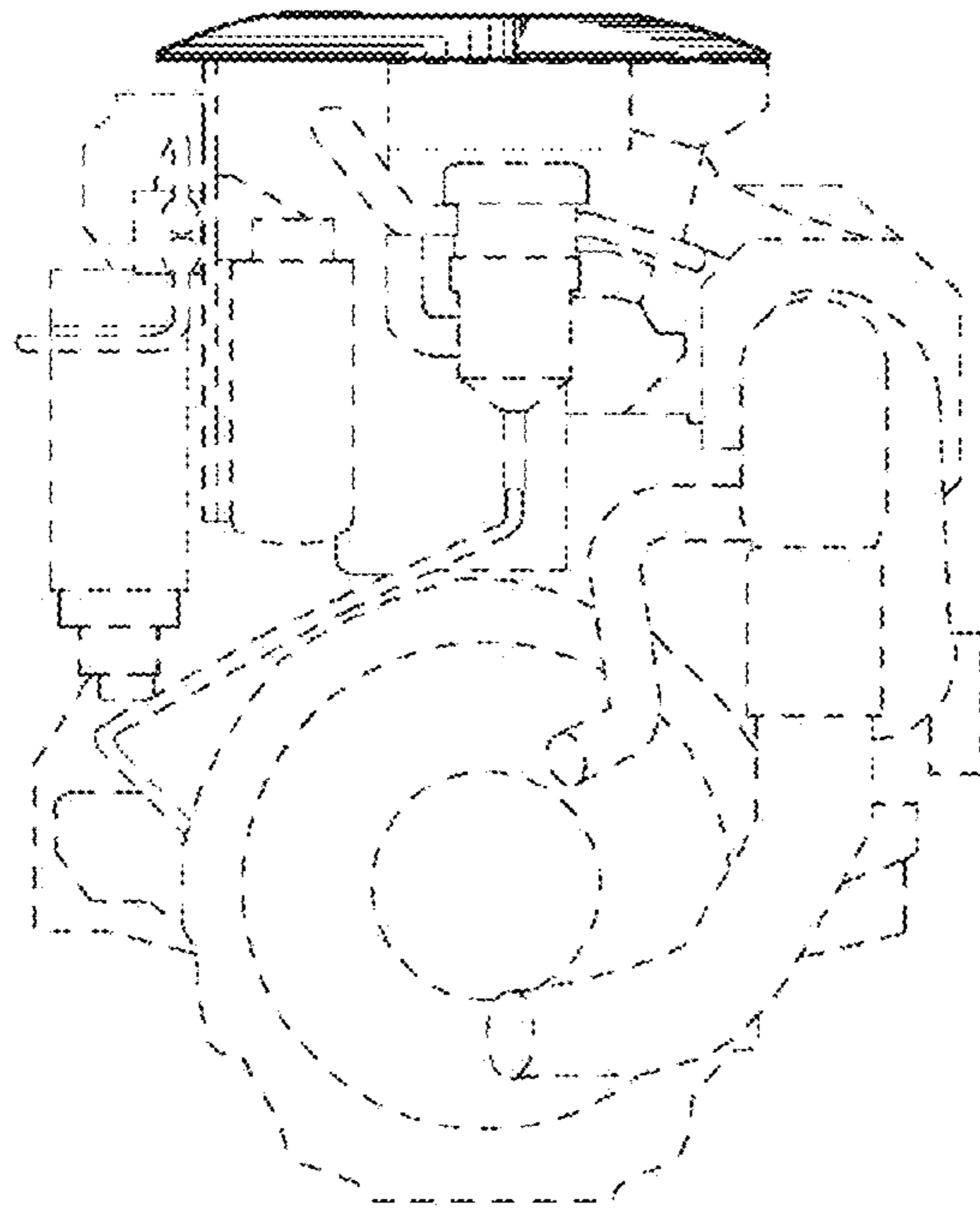

FIG. 5

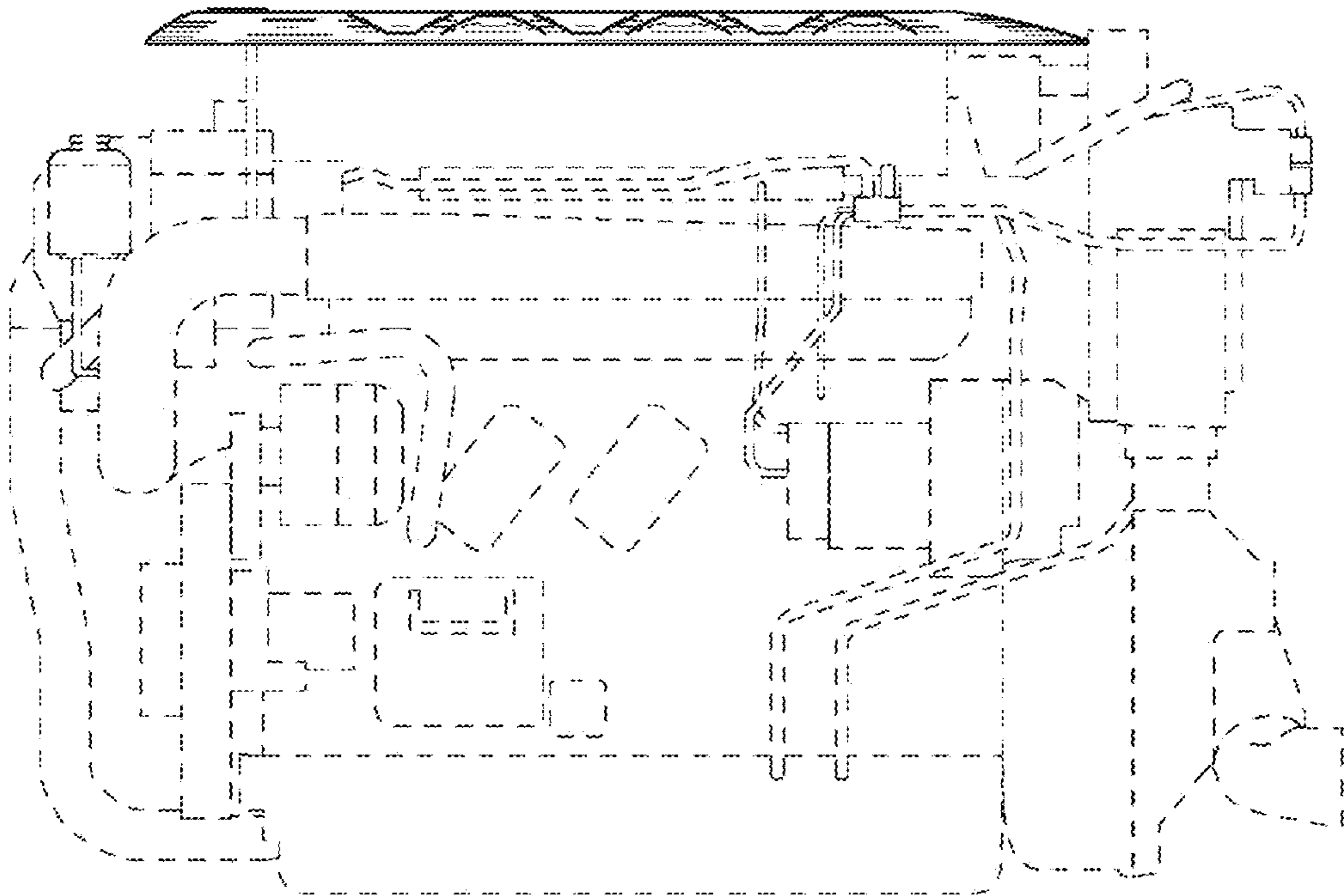

FIG. 6