



US00D754668S

(12) **United States Design Patent**  
**Manabe et al.**

(10) **Patent No.:** **US D754,668 S**  
(45) **Date of Patent:** **\*\* Apr. 26, 2016**

(54) **ELECTRONIC DEVICE STAND**

(71) Applicant: **OMRON Corporation**, Kyoto-shi,  
Kyoto (JP)  
(72) Inventors: **Seiichi Manabe**, Kusatsu (JP); **Yanping Lu**, Kusatsu (JP); **Yasuhiro Yawata**,  
Kyoto (JP); **Kazuyoshi Kamekawa**,  
Kyoto (JP)  
(73) Assignee: **OMRON CORPORATION**, Kyoto (JP)  
(\*\*) Term: **14 Years**

(21) Appl. No.: **29/515,896**

(22) Filed: **Jan. 28, 2015**

(30) **Foreign Application Priority Data**

Oct. 31, 2014 (JP) ..... 2014-024444

(51) **LOC (10) Cl.** ..... **08-07**

(52) **U.S. Cl.**  
USPC ..... **D14/447**

(58) **Field of Classification Search**  
USPC ..... D14/447, 432, 434, 439, 440, 451, 452,  
D14/457, 250, 251, 253; D3/218; D6/406.3,  
D6/406.4, 406.5, 406.6  
CPC ..... A45C 2011/003; A45C 2011/002;  
A45C 13/002; A47B 2023/049; A47B  
2097/005; A47B 2097/006; A47B 21/04;  
A47B 23/00; A47B 23/043; A47B 2021/0307;  
A47B 2023/005; F16M 2200/00; H04B  
1/3888; H04M 1/04; H04M 1/185

See application file for complete search history.

(56) **References Cited**

U.S. PATENT DOCUMENTS

D588,139	S	*	3/2009	Fujino	.....	D14/447
D598,920	S	*	8/2009	Fujino	.....	D14/447
D647,881	S	*	11/2011	Warner	.....	D14/217
D652,043	S	*	1/2012	Lee	.....	D14/447
D676,053	S	*	2/2013	Izen	.....	D14/447
D676,054	S	*	2/2013	Izen	.....	D14/447
D677,260	S	*	3/2013	Hong	.....	D14/447
D693,826	S	*	11/2013	Ashida	.....	D14/447
D714,297	S	*	9/2014	Poulsen	.....	D14/447
D716,817	S	*	11/2014	Yang	.....	D14/447
D722,063	S	*	2/2015	Zwerner	.....	D14/447
D722,064	S	*	2/2015	Zwerner	.....	D14/447
D722,065	S	*	2/2015	Zwerner	.....	D14/447

FOREIGN PATENT DOCUMENTS

JP 1429931 12/2011

\* cited by examiner

*Primary Examiner* — Angela J Lee

(74) *Attorney, Agent, or Firm* — Harness, Dickey & Pierce,  
P.L.C.

(57) **CLAIM**

The ornamental design for an electronic device stand, as shown and described.

**DESCRIPTION**

FIG. 1 is a front perspective view of an electronic device stand;  
FIG. 2 is a front elevational view thereof;  
FIG. 3 is a rear elevational view thereof;  
FIG. 4 is a left side view thereof;  
FIG. 5 is a right side view thereof;  
FIG. 6 is a top plan view thereof; and,  
FIG. 7 is a bottom plan view thereof.

**1 Claim, 7 Drawing Sheets**

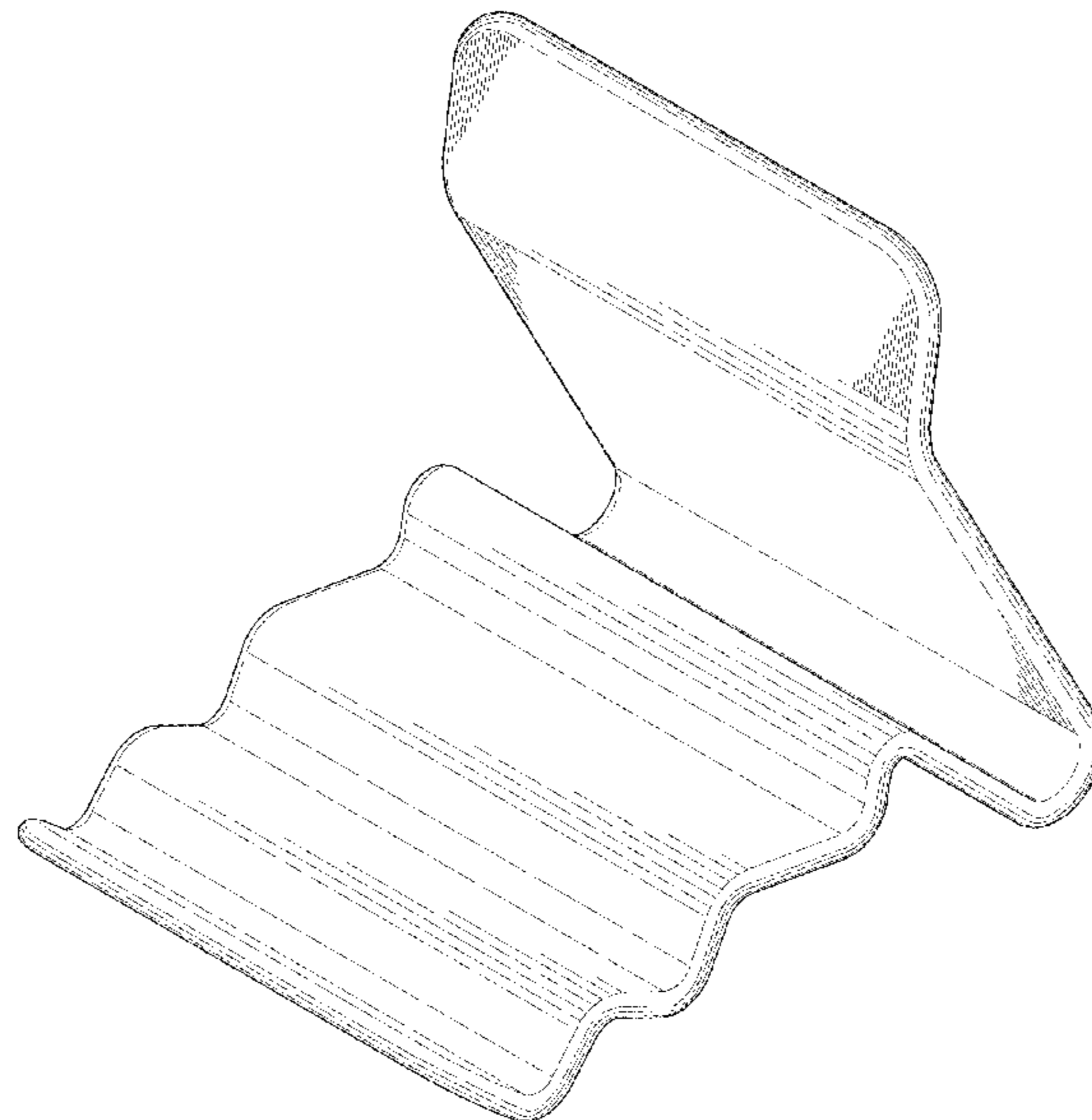

Fig. 1

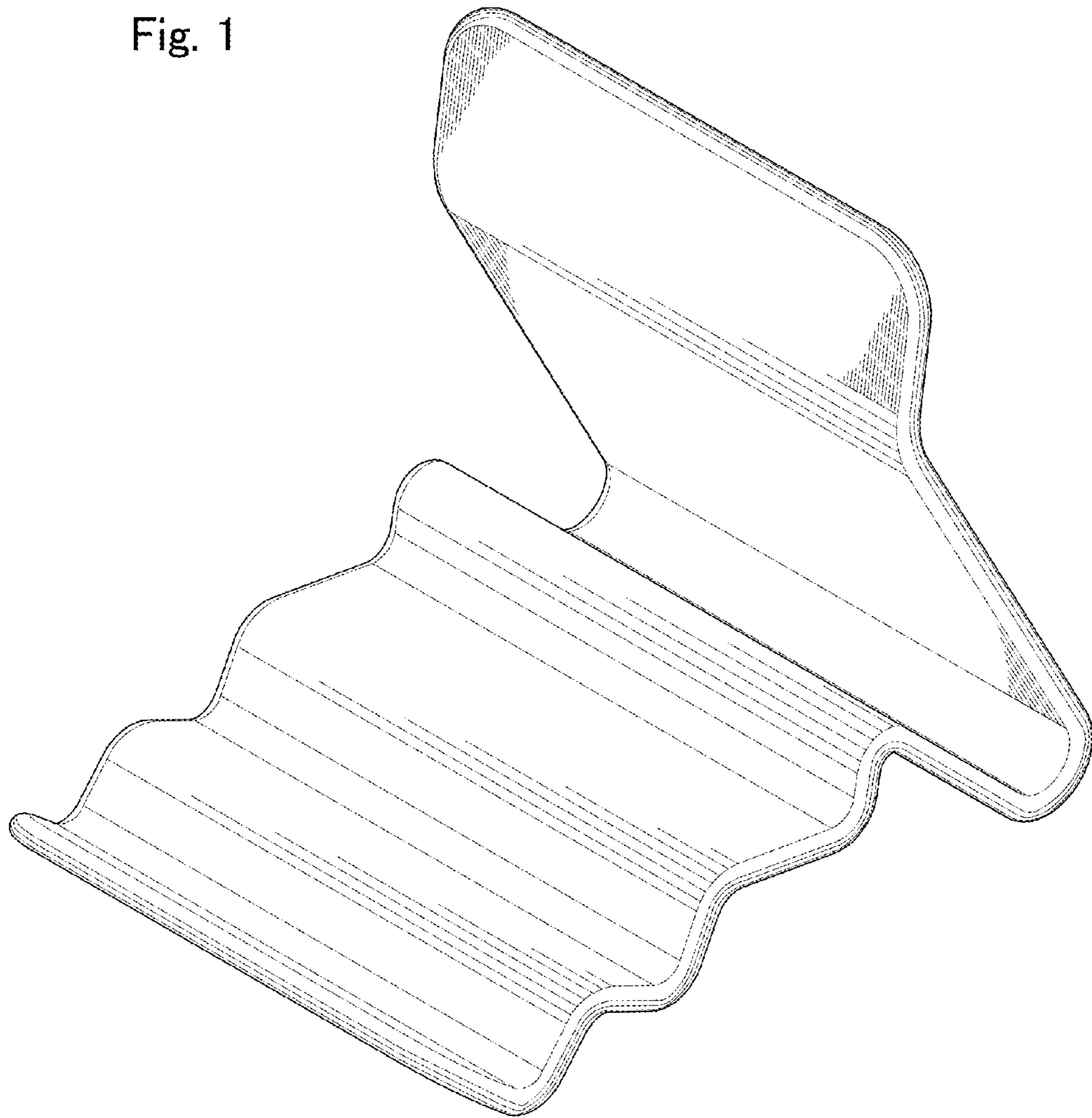

Fig. 2

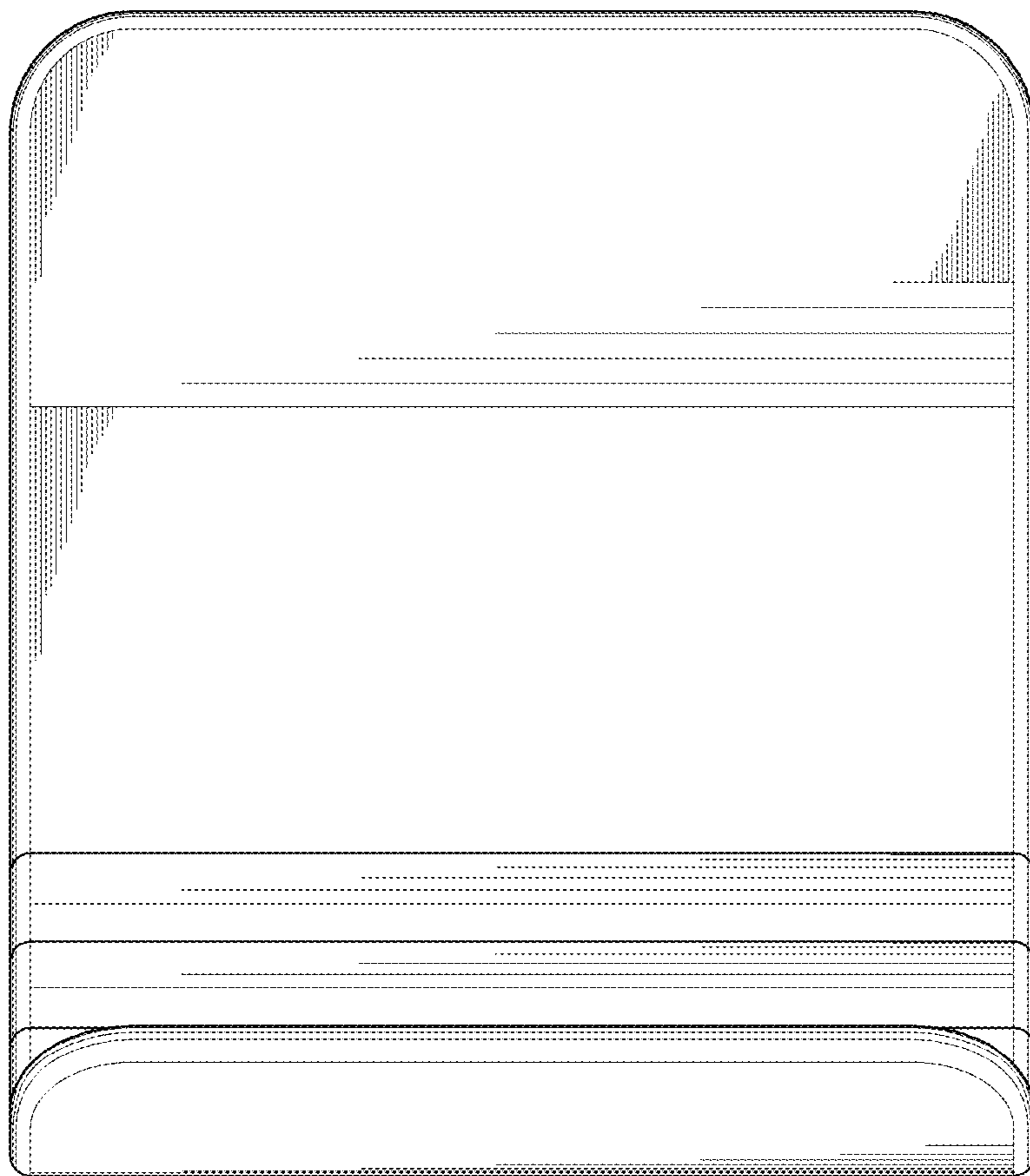

Fig. 3

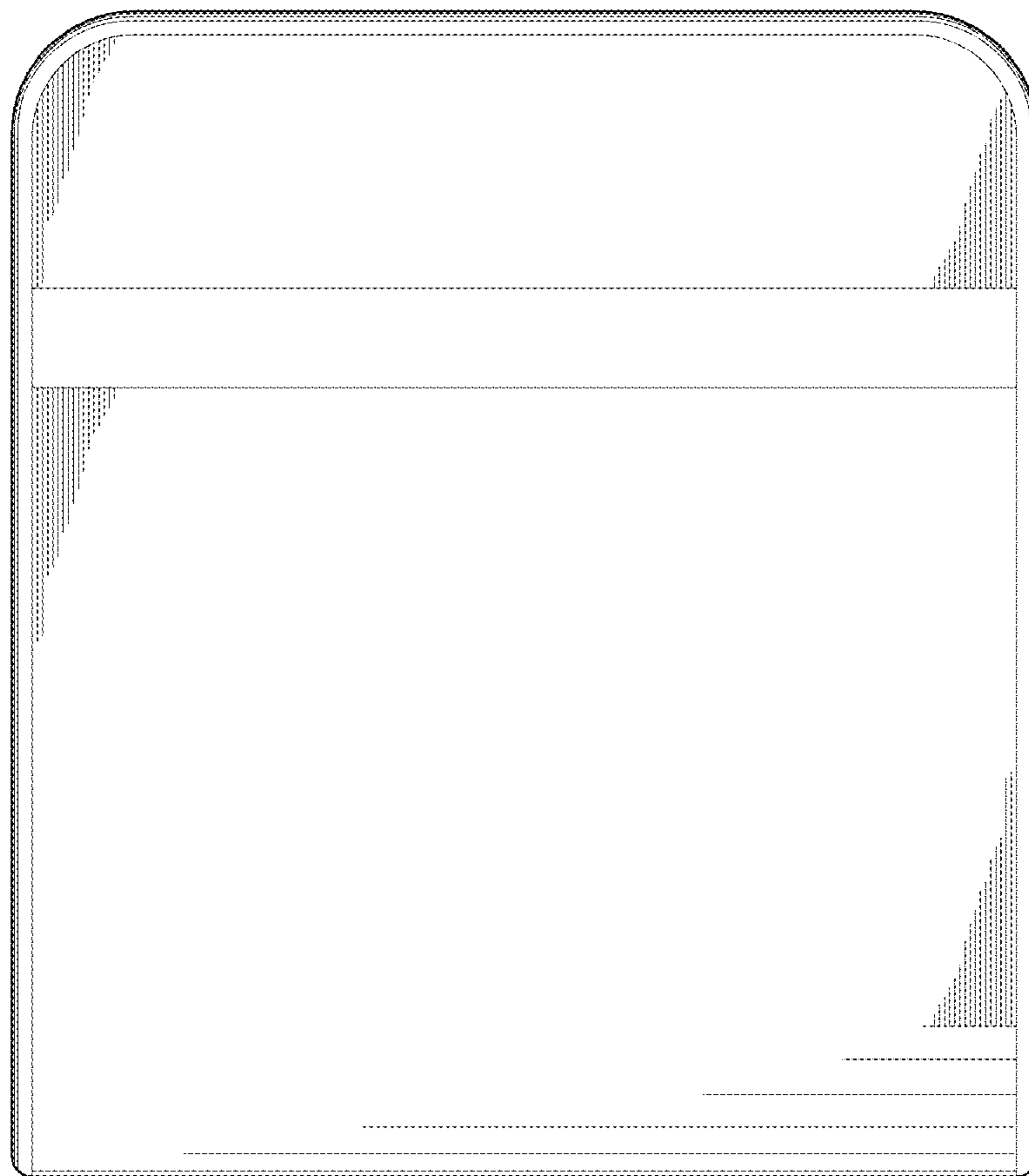

Fig. 4

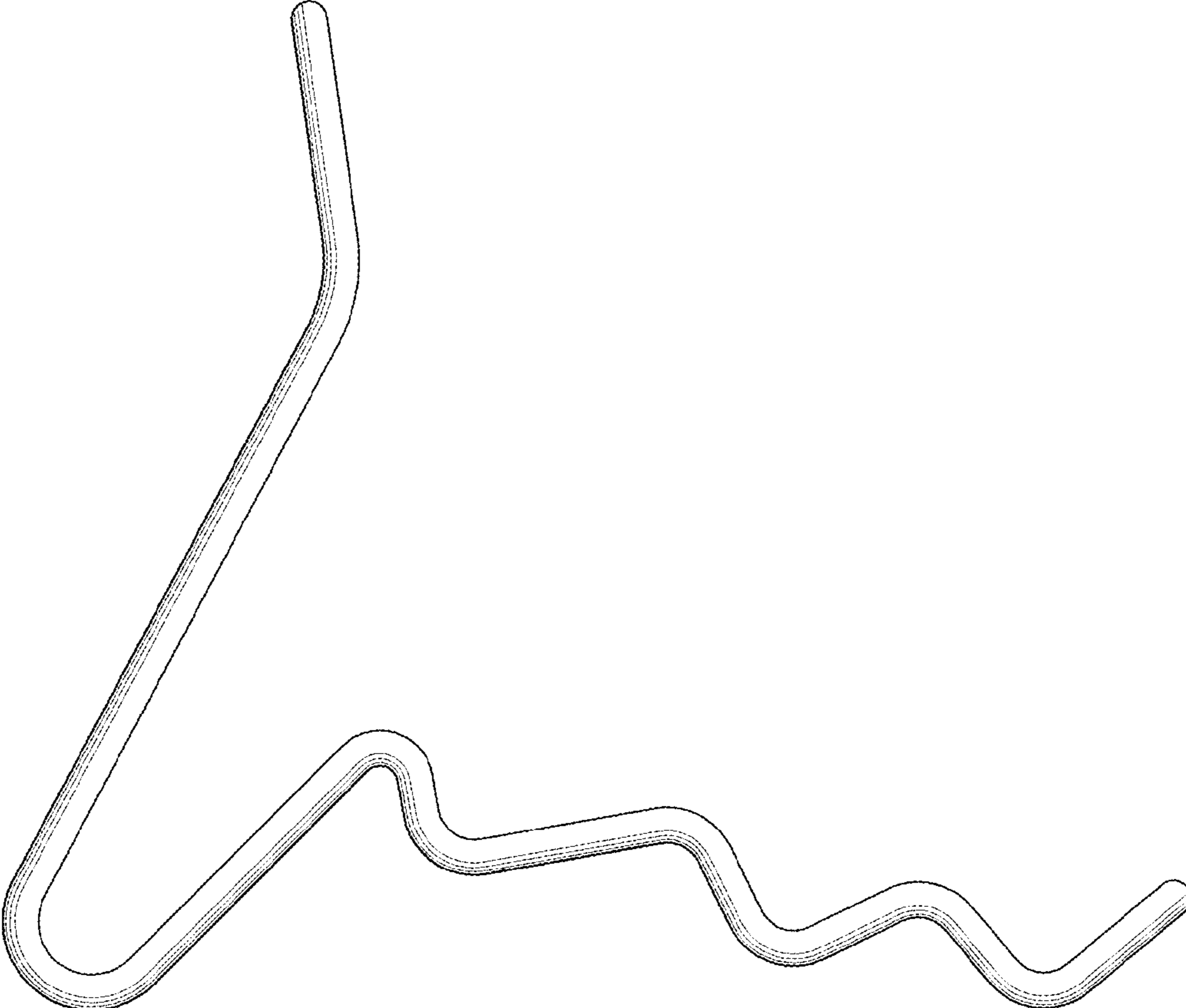

Fig. 5

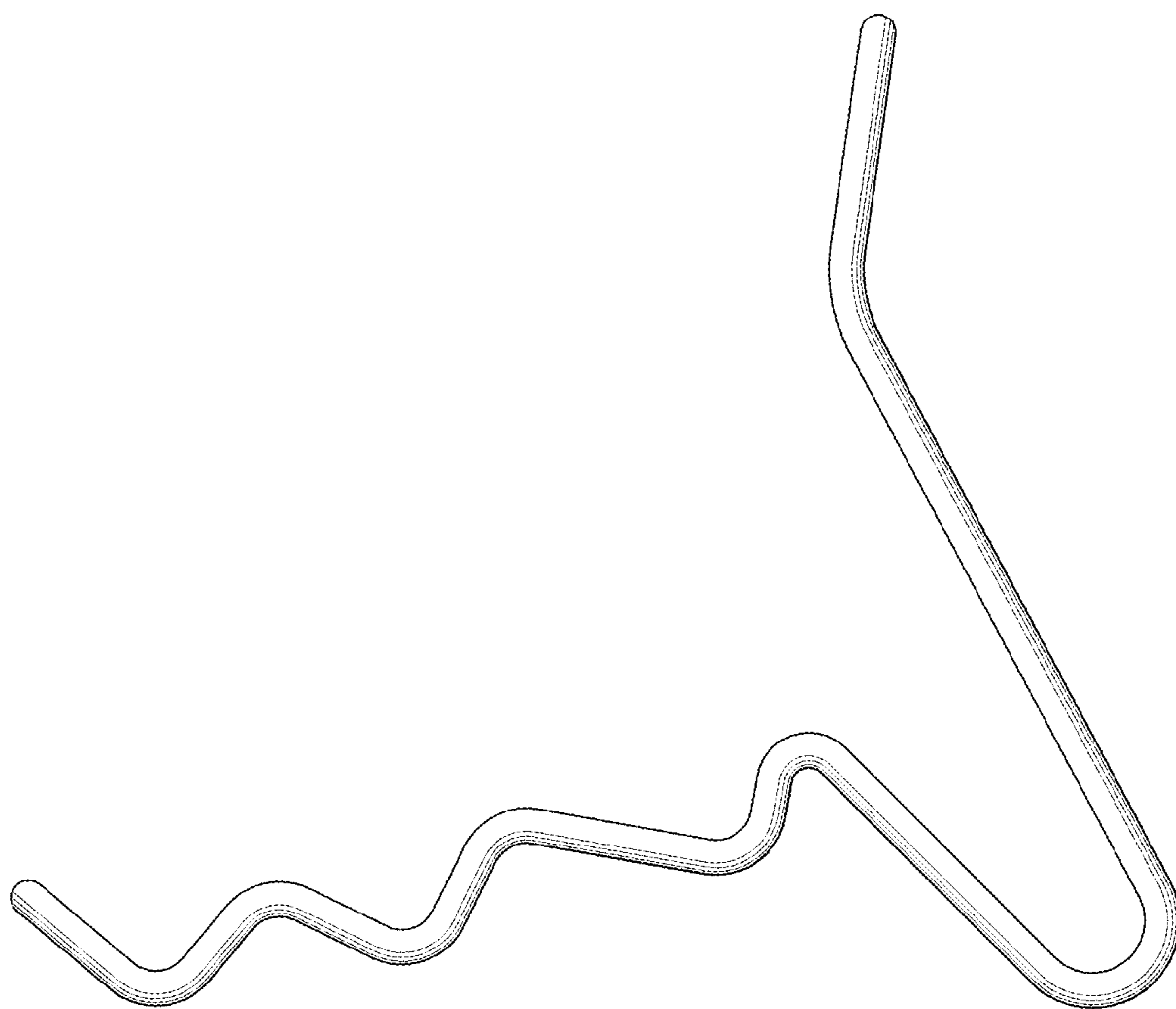



Fig. 6

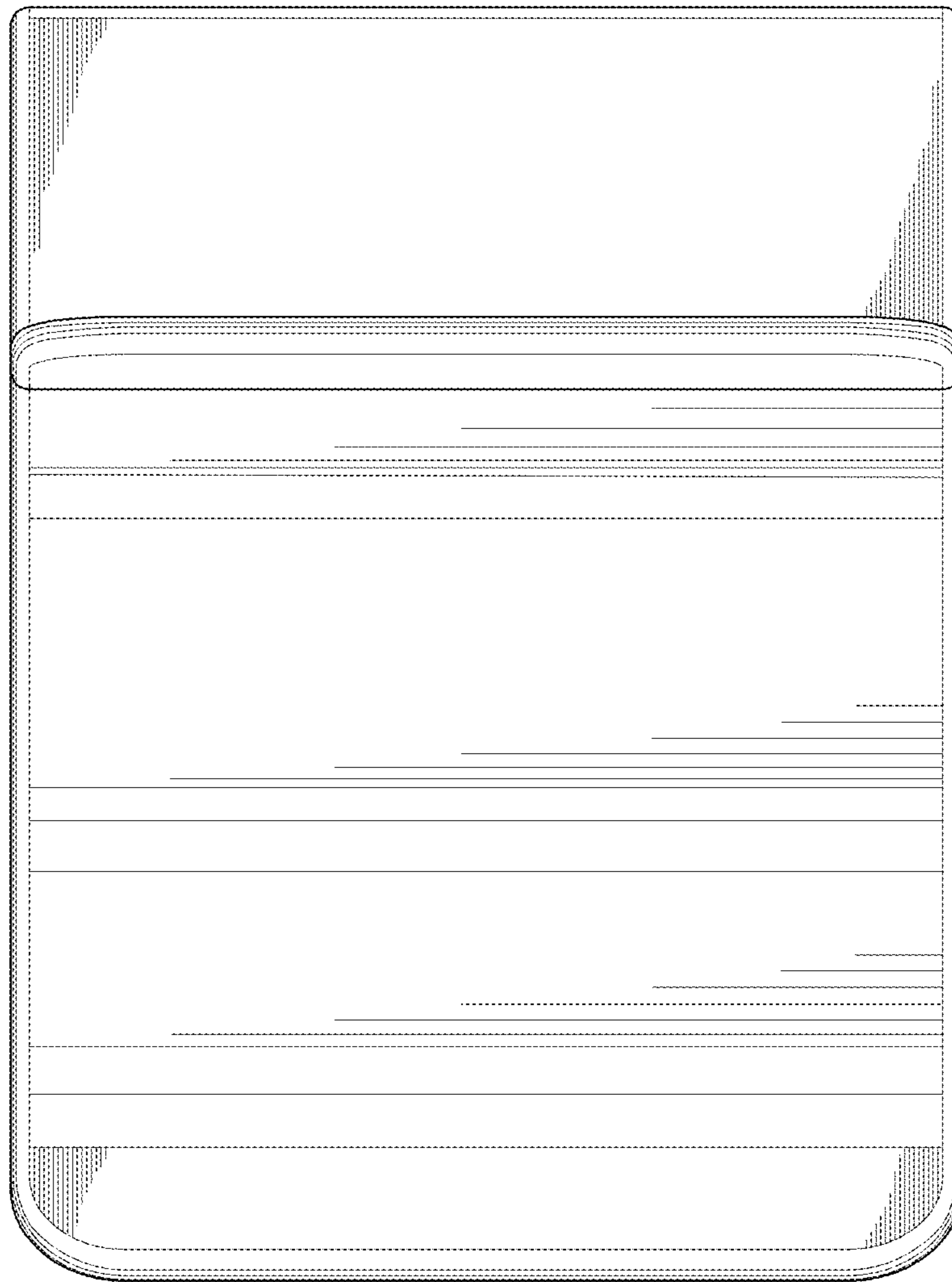

Fig. 7

