



US00D754400S

(12) **United States Design Patent**  
**Andersson**

(10) **Patent No.:** **US D754,400 S**  
(45) **Date of Patent:** **\*\* Apr. 19, 2016**

(54) **COMB FOR GROOMING APPARATUS**

(71) Applicant: **KONINKLIJKE PHILIPS N.V.**,  
Eindhoven (NL)

(72) Inventor: **Jens Peter Kophmann Andersson**,  
Amsterdam (NL)

(73) Assignee: **KONINKLIJKE PHILIPS N.V.**,  
Eindhoven (NL)

(\*\*) Term: **14 Years**

(21) Appl. No.: **29/513,584**

(22) Filed: **Jan. 2, 2015**

(30) **Foreign Application Priority Data**

Jul. 4, 2014 (EM) ..... 002496497-0002

(51) **LOC (10) CL.** ..... **28-03**

(52) **U.S. CL.**  
USPC ..... **D28/54**

(58) **Field of Classification Search**  
USPC ..... D28/54, 53, 52, 49, 51  
CPC .. B26B 19/20; B26B 19/205; B26B 19/3813;  
B26B 19/38; B26B 19/3806

See application file for complete search history.

(56) **References Cited**

**U.S. PATENT DOCUMENTS**

D286,454 S \* 10/1986 Stephens ..... D28/54  
5,054,199 A \* 10/1991 Ogawa ..... B26B 19/06  
30/200  
5,479,950 A \* 1/1996 Andrews ..... A45D 24/36

132/215  
D463,623 S \* 9/2002 Kling ..... D28/54  
D524,487 S \* 7/2006 Seki ..... D28/54  
D530,858 S \* 10/2006 Kling ..... D28/54  
D558,400 S \* 12/2007 Micinilio ..... D28/54  
D559,456 S \* 1/2008 Melton ..... D28/54  
D565,793 S \* 4/2008 Wallace ..... D28/54  
D574,557 S \* 8/2008 Kling ..... D28/54  
D591,455 S \* 4/2009 Micinilio ..... D28/54  
D591,907 S \* 5/2009 Micinilio ..... D28/54  
D616,606 S \* 5/2010 Adams ..... D28/47  
D617,497 S \* 6/2010 Goodhead ..... D28/47  
D619,301 S \* 7/2010 Wattam ..... D28/47  
D619,304 S \* 7/2010 Shen ..... D28/54  
D620,196 S \* 7/2010 Nicoll ..... D28/47  
D722,201 S \* 2/2015 Boulanger ..... D28/54  
2008/0289192 A1 \* 11/2008 Martelli ..... B26B 19/20  
30/233.5  
2014/0215832 A1 \* 8/2014 Julemont ..... B26B 19/20  
30/200

\* cited by examiner

*Primary Examiner* — Jennifer Rivard

(57) **CLAIM**

The ornamental design for a comb for grooming apparatus, as shown.

**DESCRIPTION**

FIG. 1 is a perspective view showing my design;  
FIG. 2 is a front elevational view thereof;  
FIG. 3 is a rear elevational view thereof;  
FIG. 4 is a right side elevational view thereof;  
FIG. 5 is a left side elevational view thereof;  
FIG. 6 is a top plan view thereof; and,  
FIG. 7 is a bottom plan view thereof.

**1 Claim, 4 Drawing Sheets**

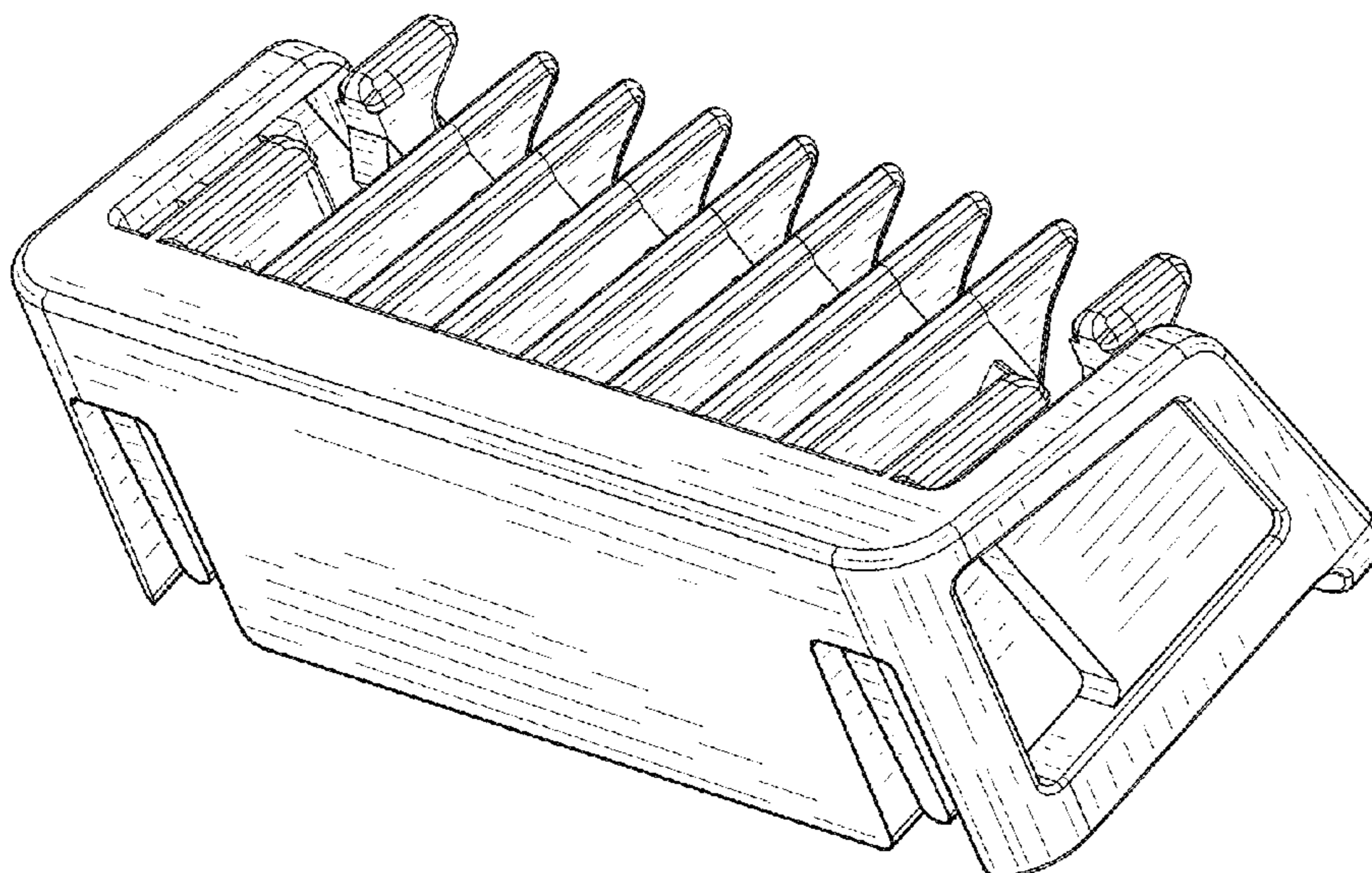

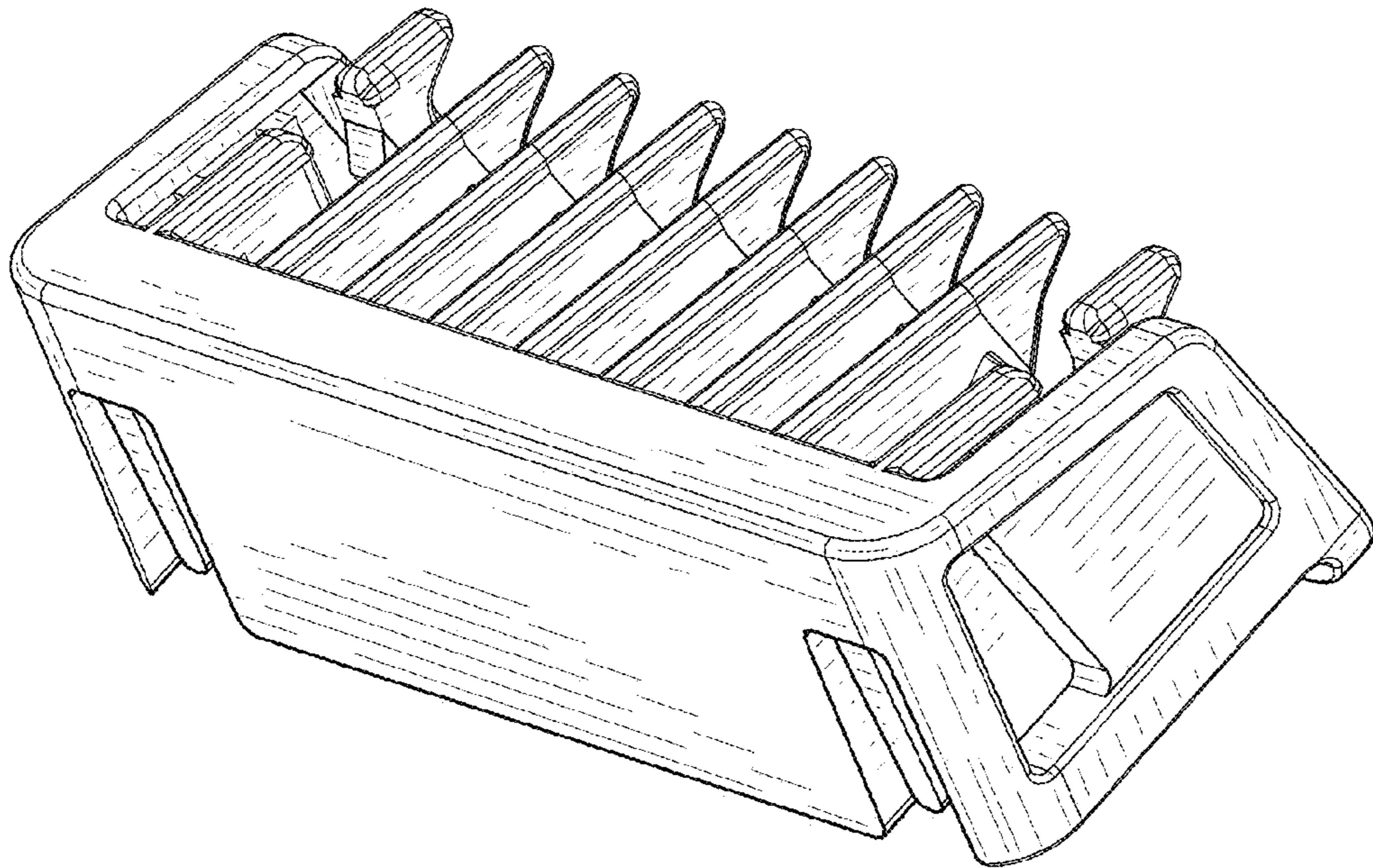

FIG. 1

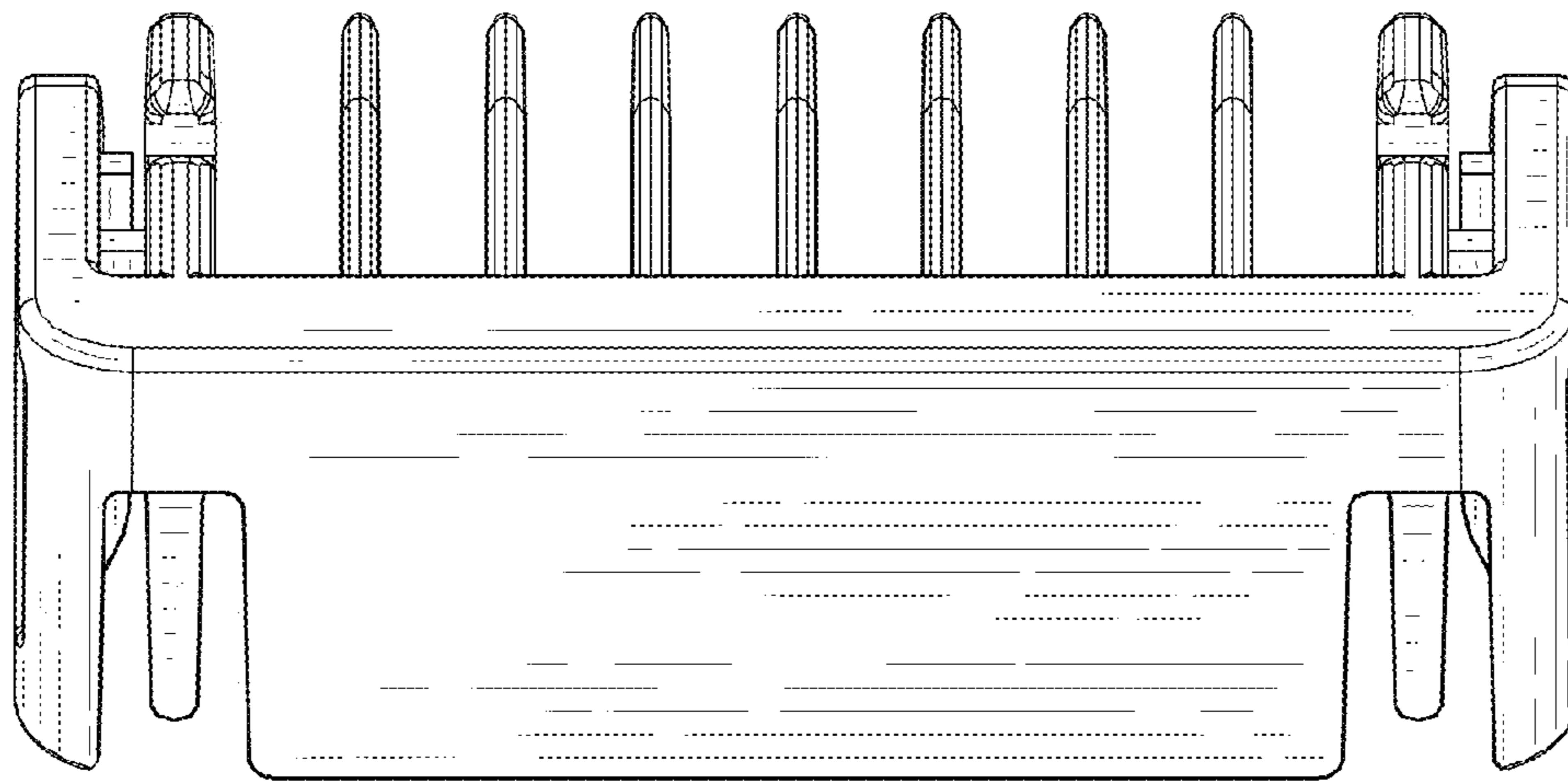

FIG. 2

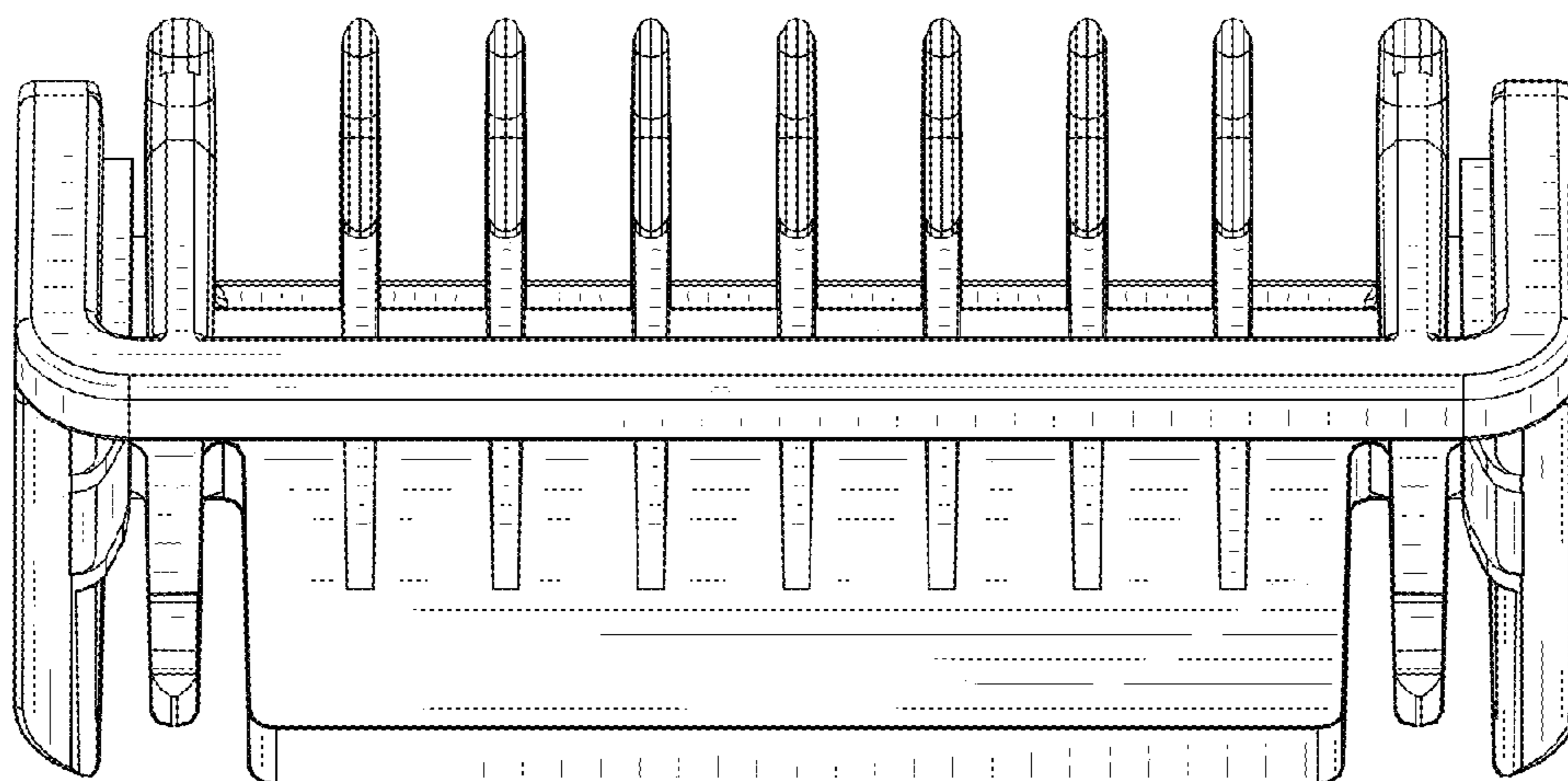

FIG. 3

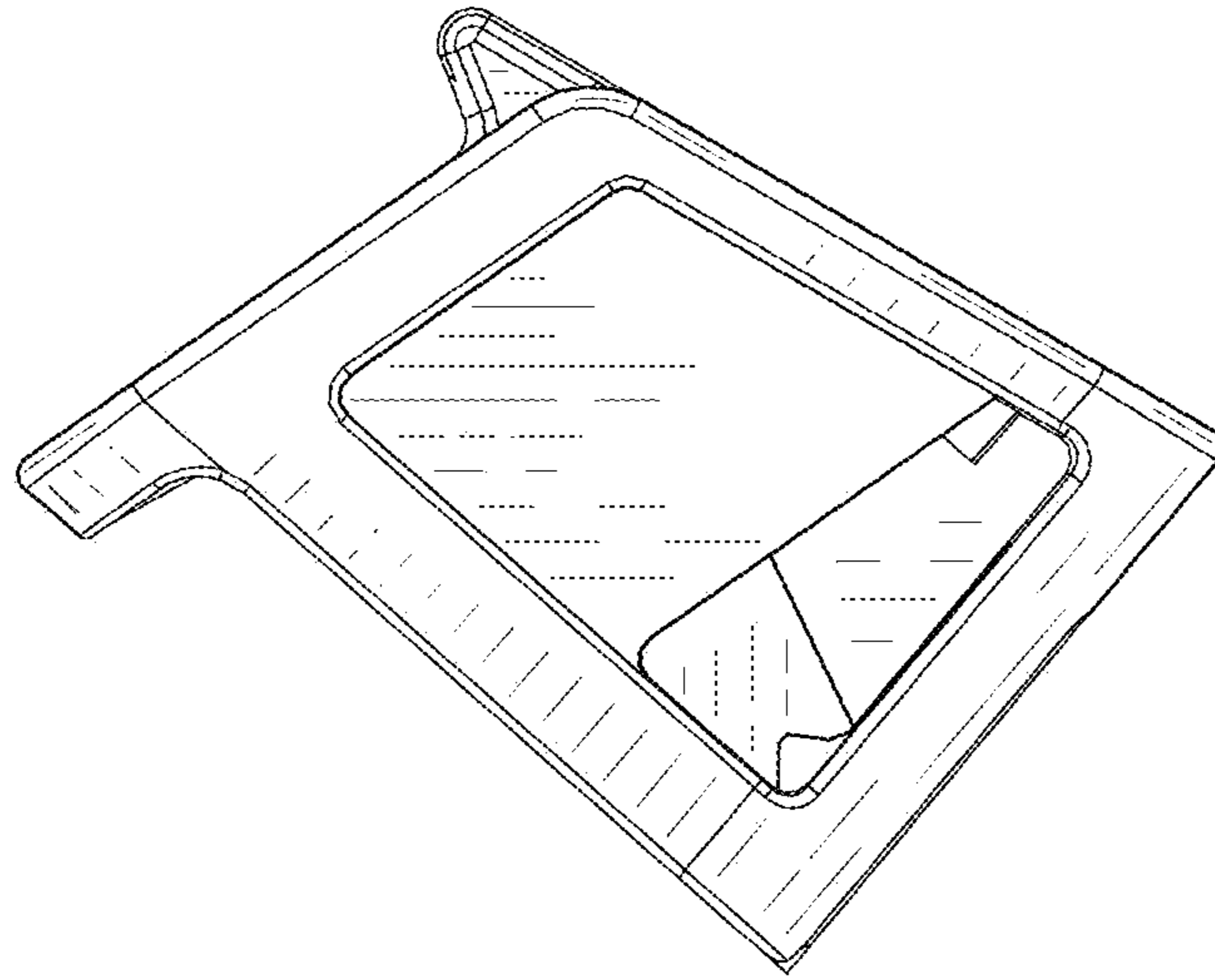

FIG. 4

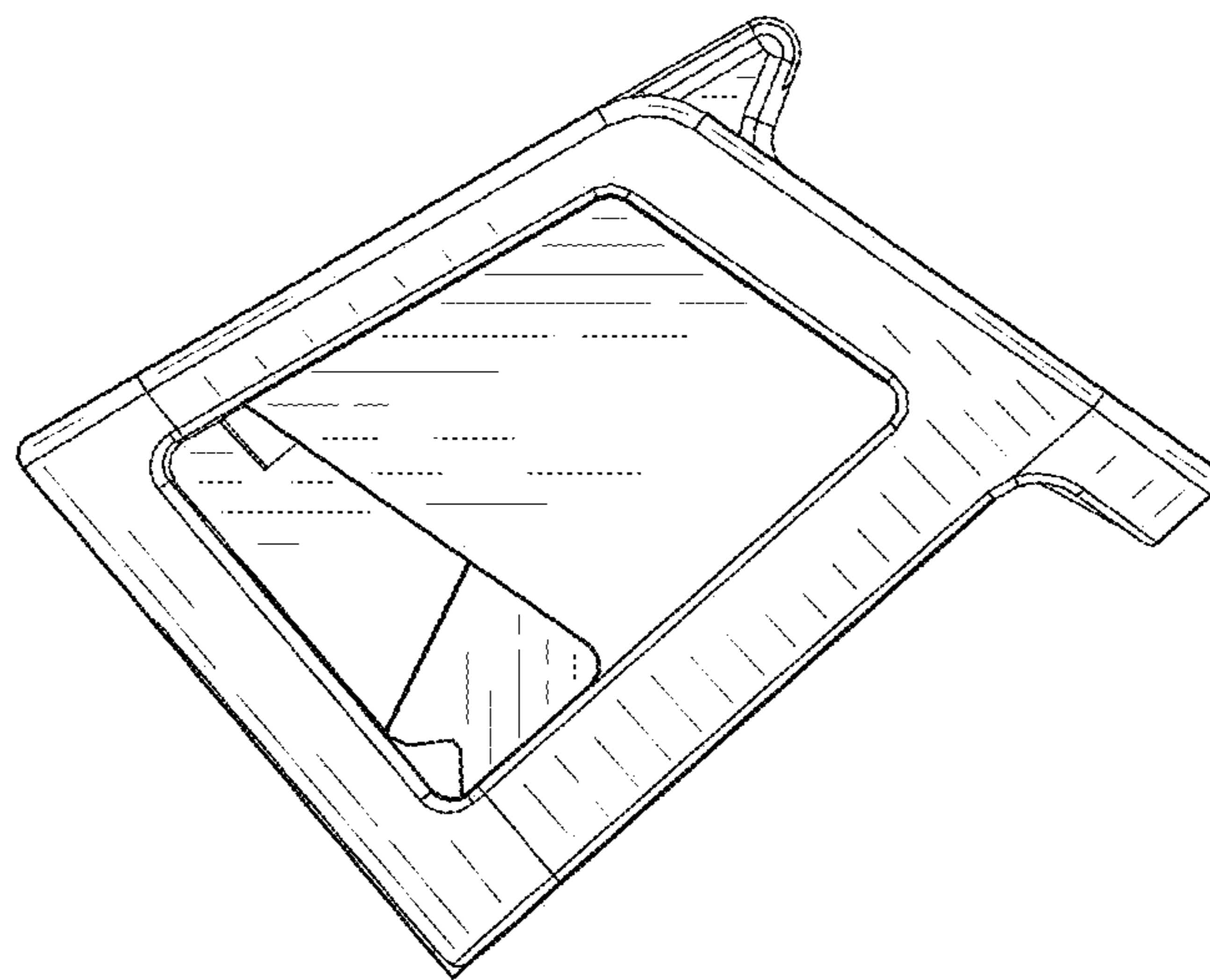

FIG. 5

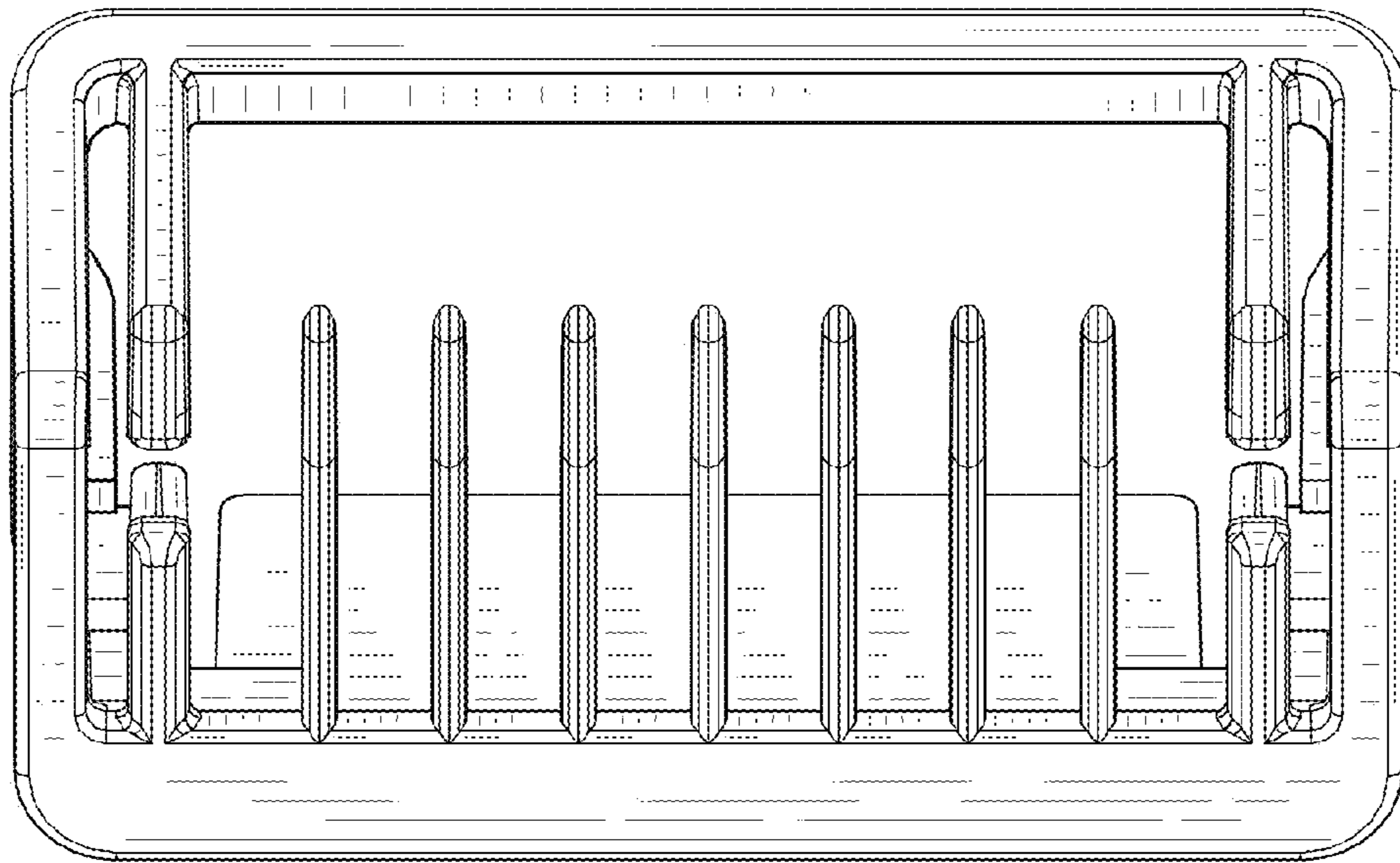

FIG. 6

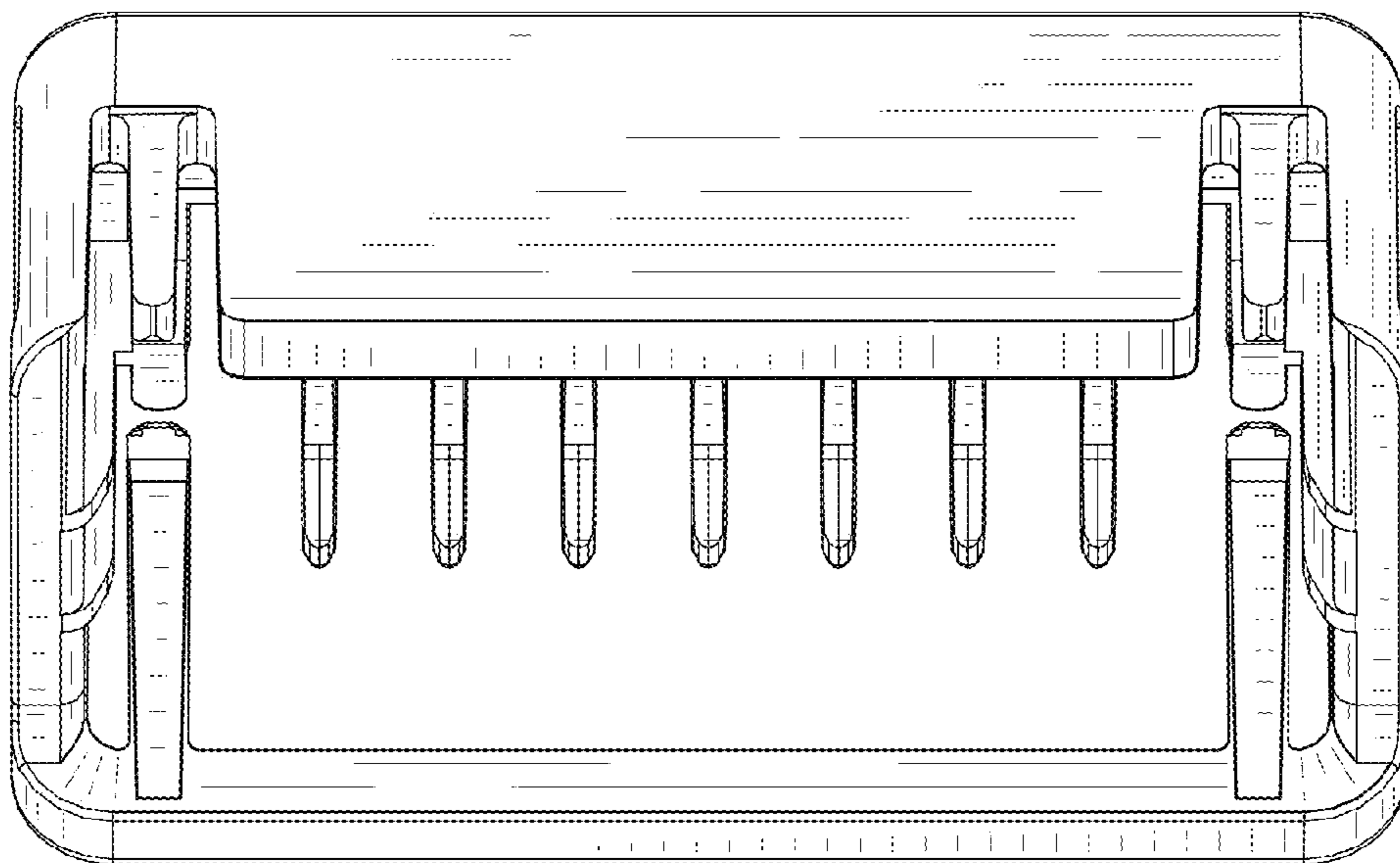

FIG. 7