



US00D754388S

(12) **United States Design Patent**
Hsu

(10) **Patent No.:** **US D754,388 S**
(45) **Date of Patent:** **** Apr. 19, 2016**

(54) **LENS FOR A VEHICLE LAMP**

(71) Applicant: **Chen-Wei Hsu**, Tainan (TW)

(72) Inventor: **Chen-Wei Hsu**, Tainan (TW)

(**) Term: **14 Years**

(21) Appl. No.: **29/510,074**

(22) Filed: **Nov. 25, 2014**

(51) **LOC (10) Cl.** **26-99**

(52) **U.S. Cl.**
USPC **D26/139**

(58) **Field of Classification Search**
USPC D26/28-36, 139; 362/459-468,
362/475-478, 485-487
CPC F21S 48/00; F21S 48/10; F21S 48/115;
F21S 48/225; F21S 48/1233; F21S 48/1266;
F21S 48/1388; F21S 48/2268; F21V 21/04
See application file for complete search history.

(56) **References Cited**

U.S. PATENT DOCUMENTS

D189,932 S * 3/1961 Walker D26/139
D469,213 S * 1/2003 Huang D26/139

D571,033 S * 6/2008 Gordin D26/118

* cited by examiner

Primary Examiner — Marcus Jackson

(57) **CLAIM**

The ornamental design for a lens for a vehicle lamp, is as shown and described.

DESCRIPTION

FIG. 1 is a perspective view of a lens for a vehicle lamp showing my design;
FIG. 2 is other perspective view thereof,
FIG. 3 is a front elevational view thereof;
FIG. 4 is a rear elevational view thereof;
FIG. 5 is a left side elevational view thereof;
FIG. 6 is a right side elevational view thereof;
FIG. 7 is a top plan view thereof;
FIG. 8 is a bottom plan view thereof; and,
FIG. 9 is a schematic view of the lens for a vehicle lamp in a using condition.

The ornamental design which is claimed is shown in solid lines in the drawings. The broken lines in the drawings are for illustrative purposes only and form no part of the claimed design.

1 Claim, 6 Drawing Sheets

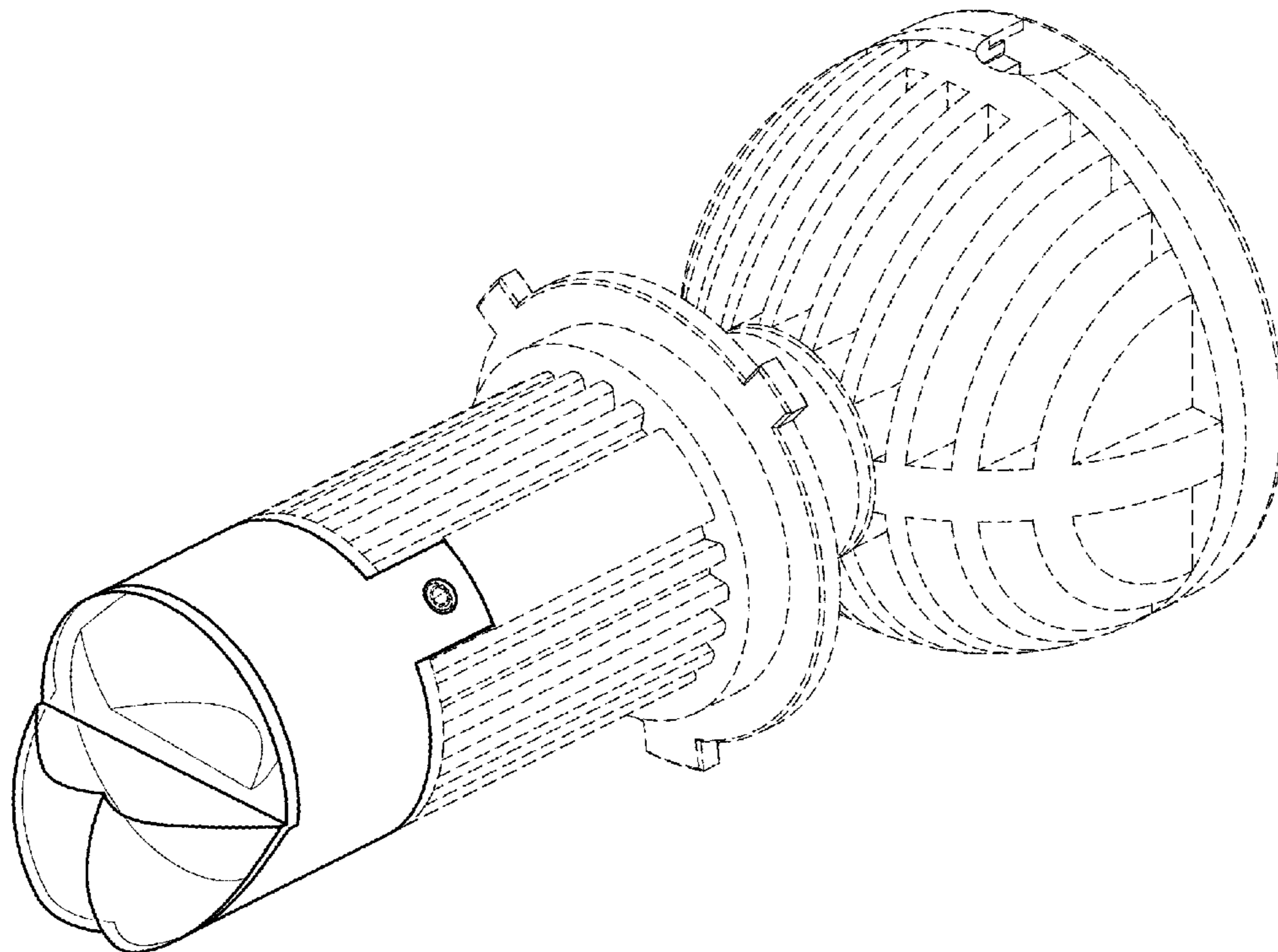

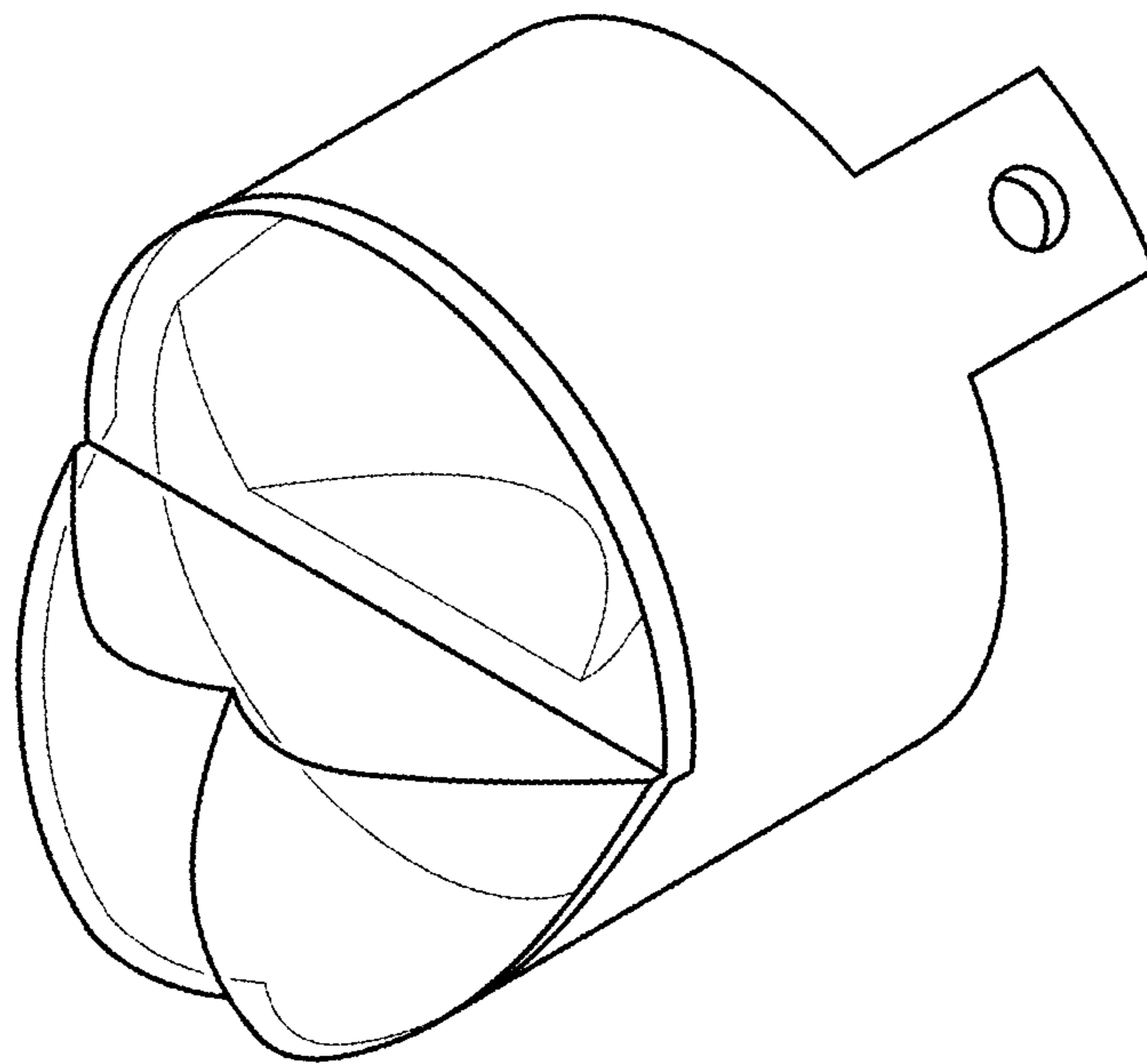

FIG.1

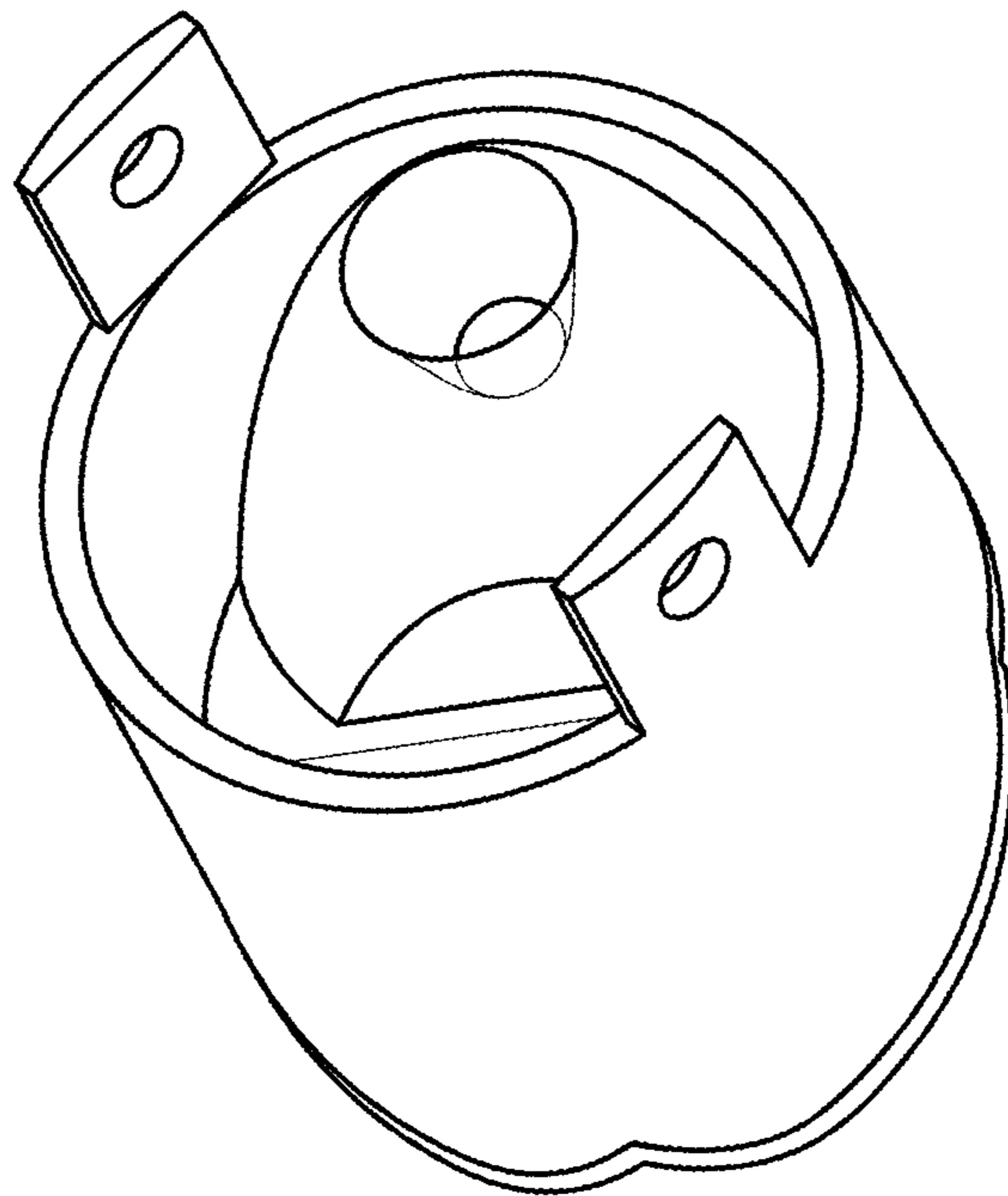

FIG.2

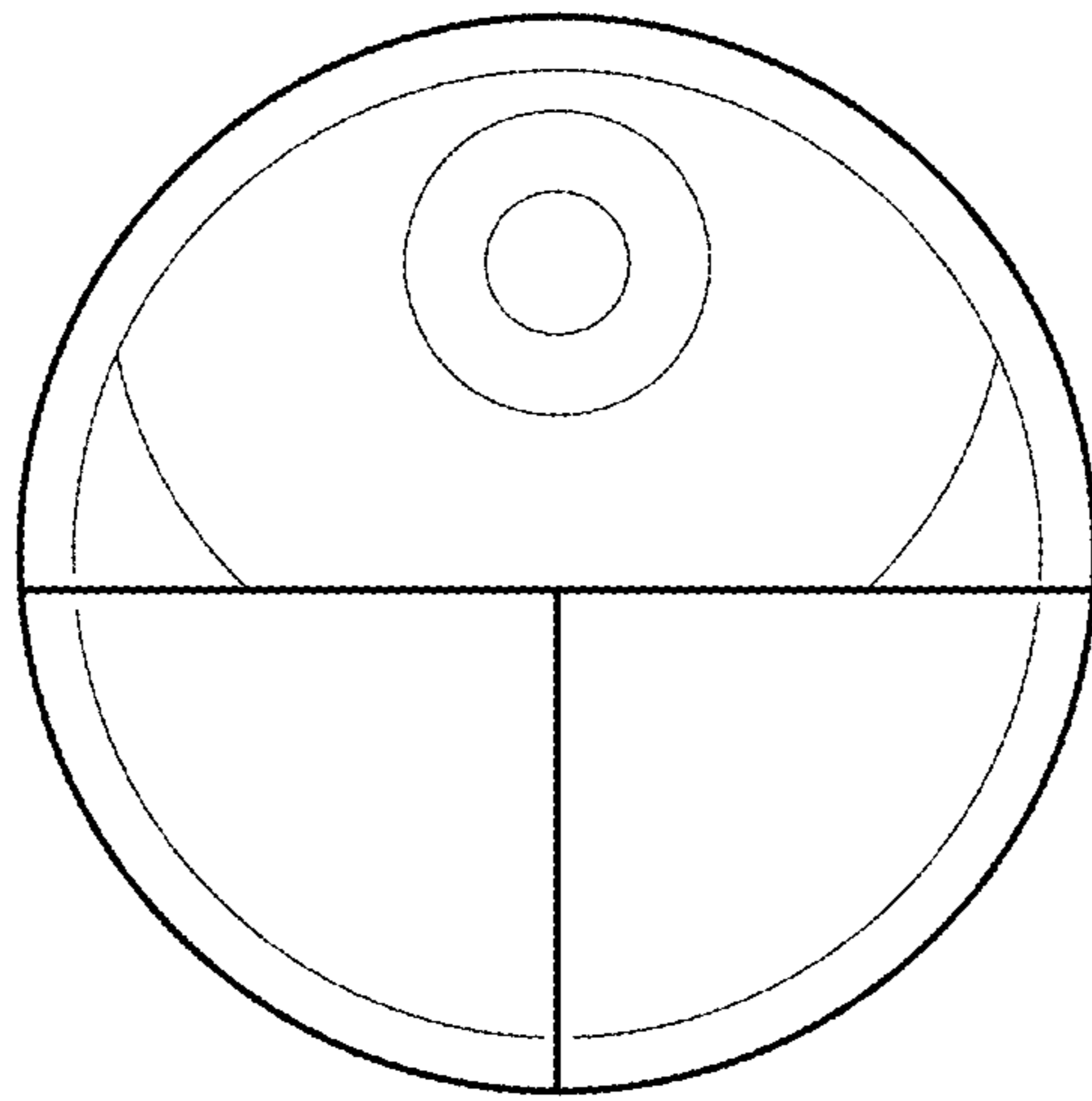

FIG. 3

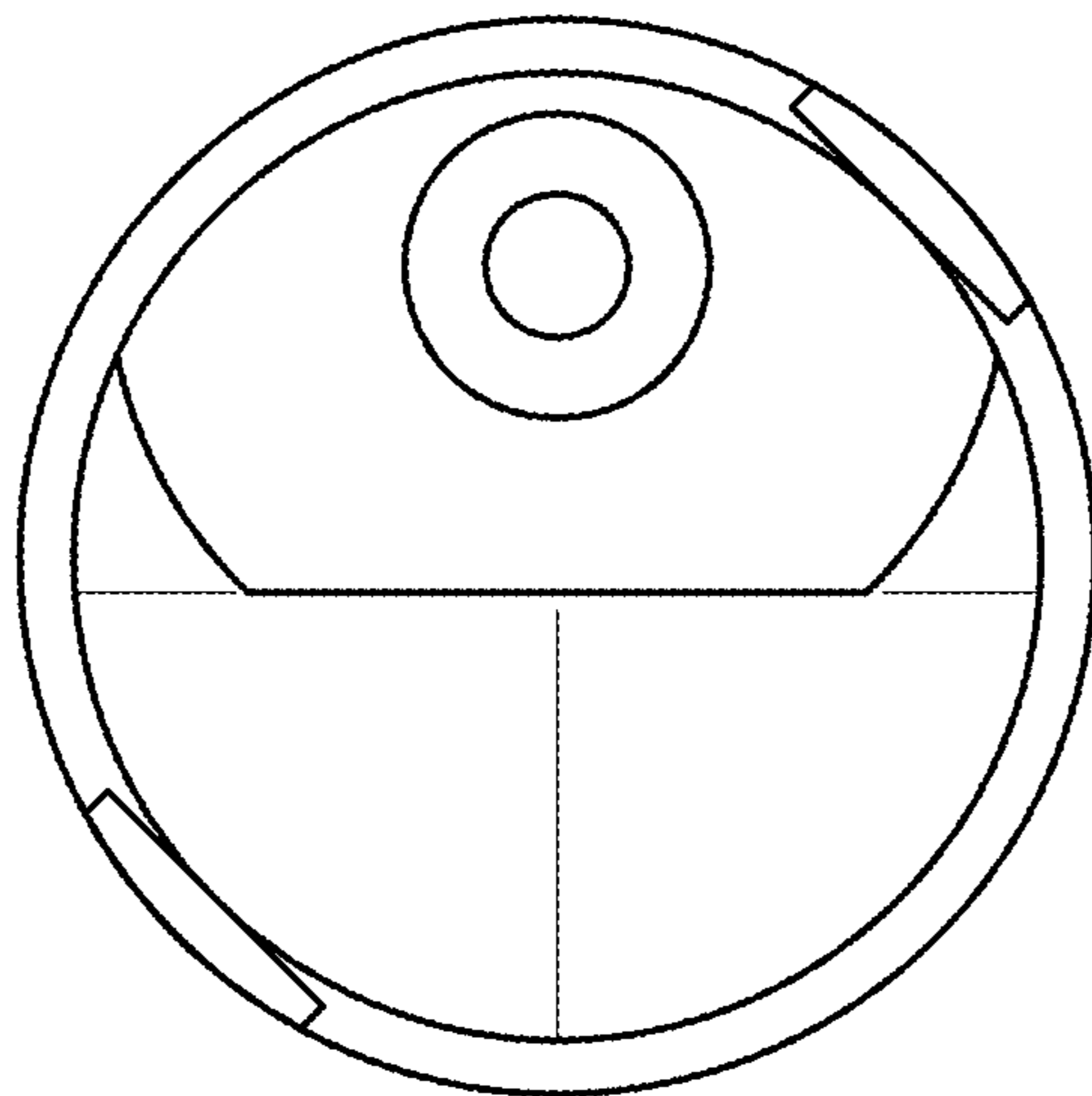

FIG. 4

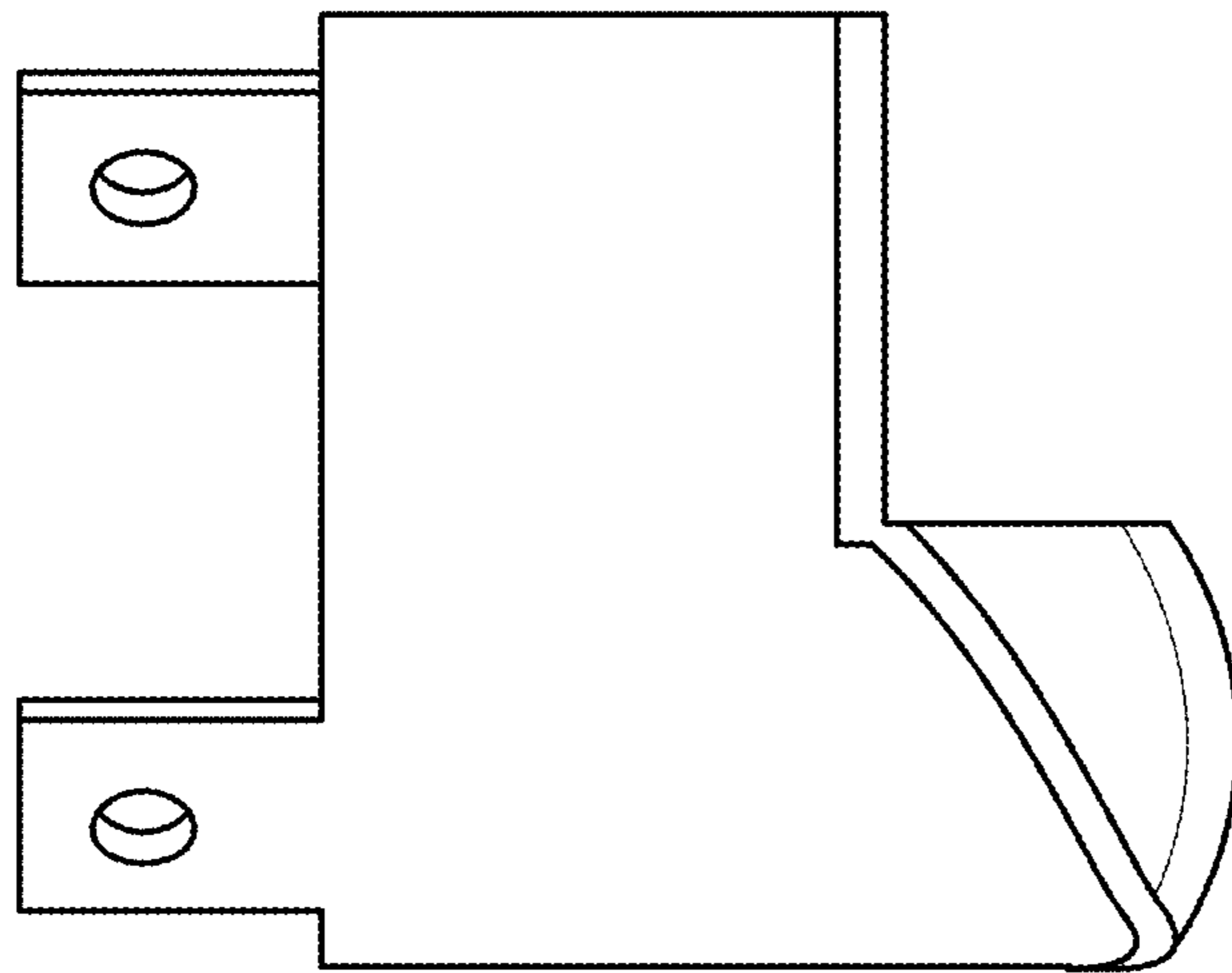

FIG. 5

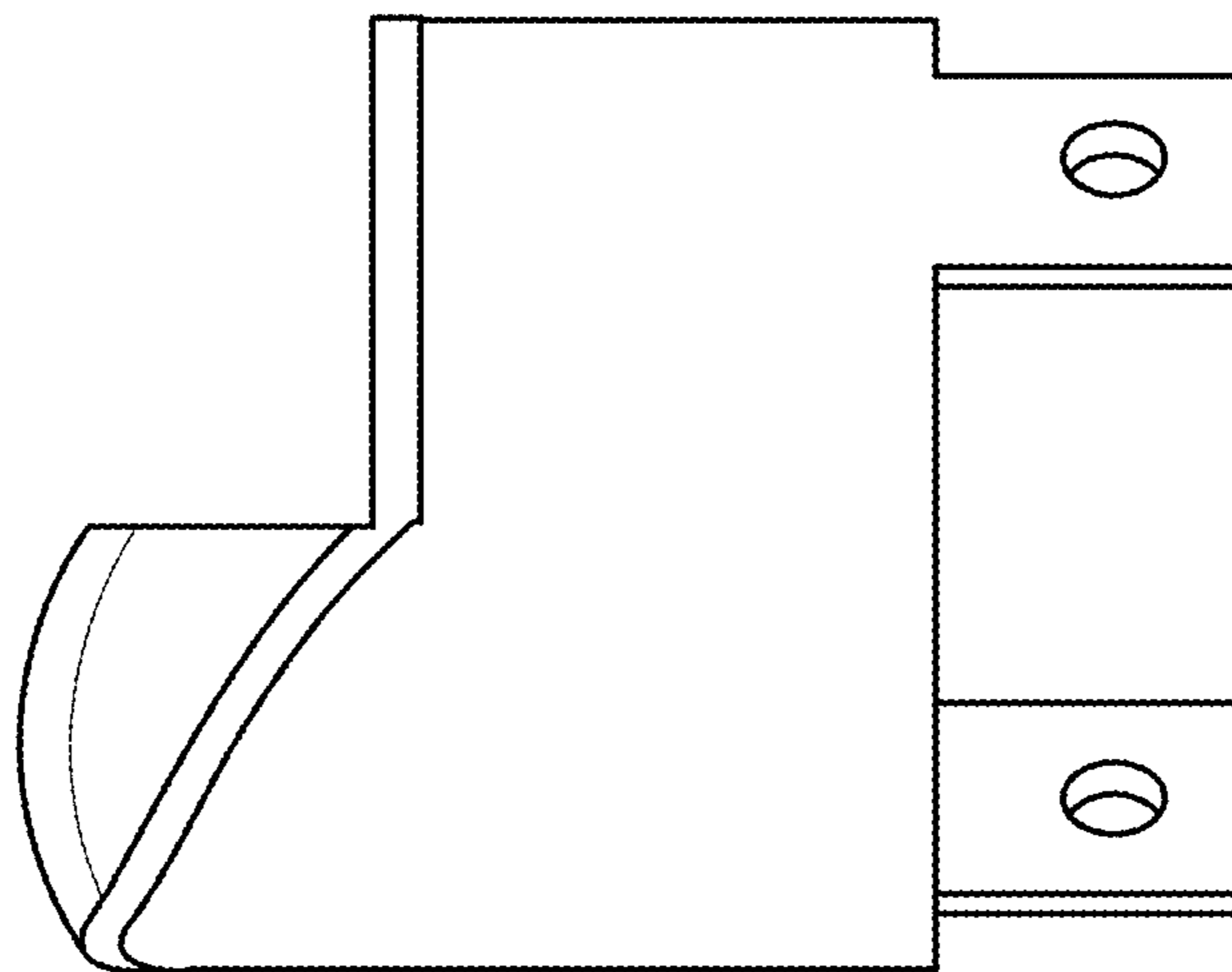

FIG. 6

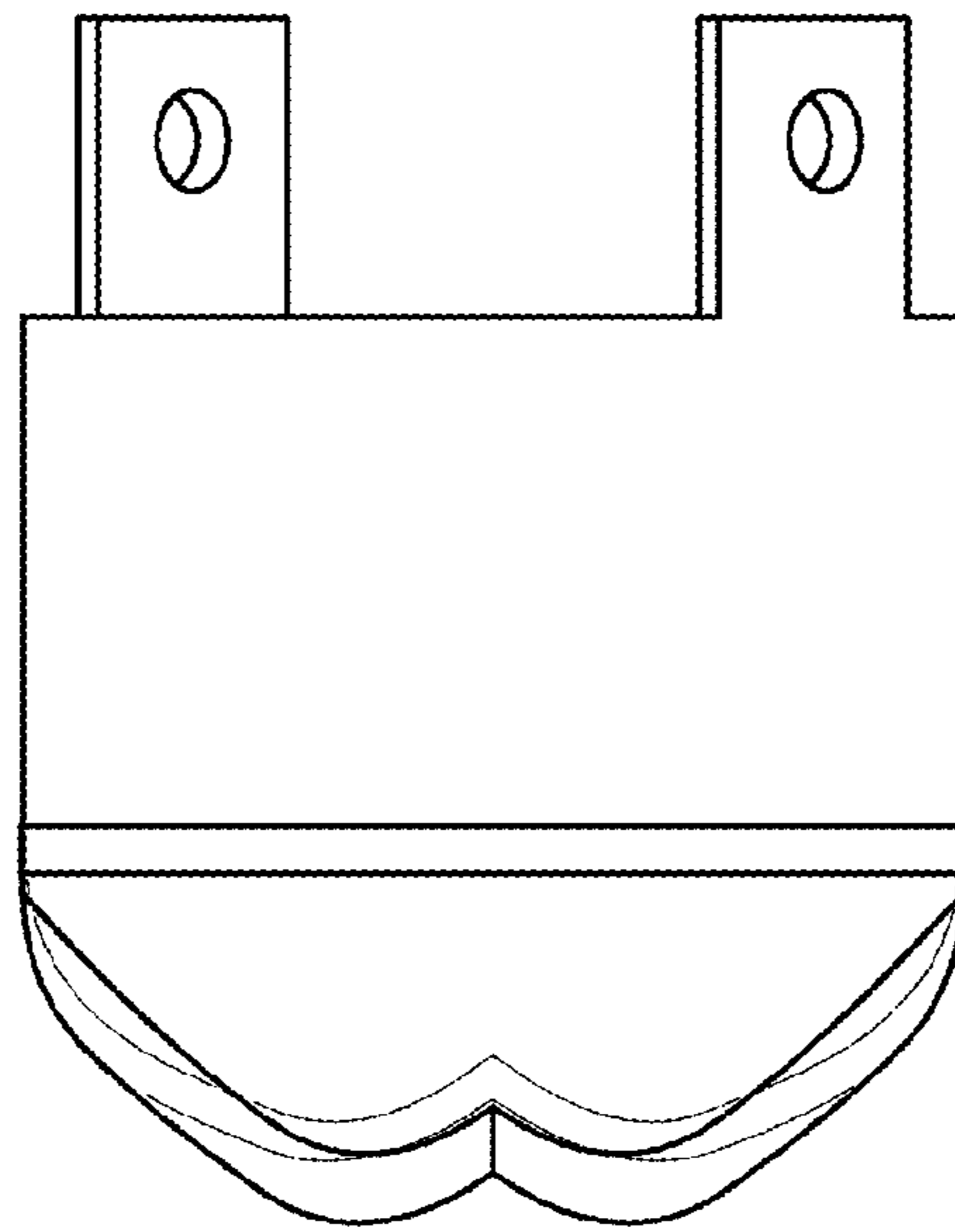

FIG. 7

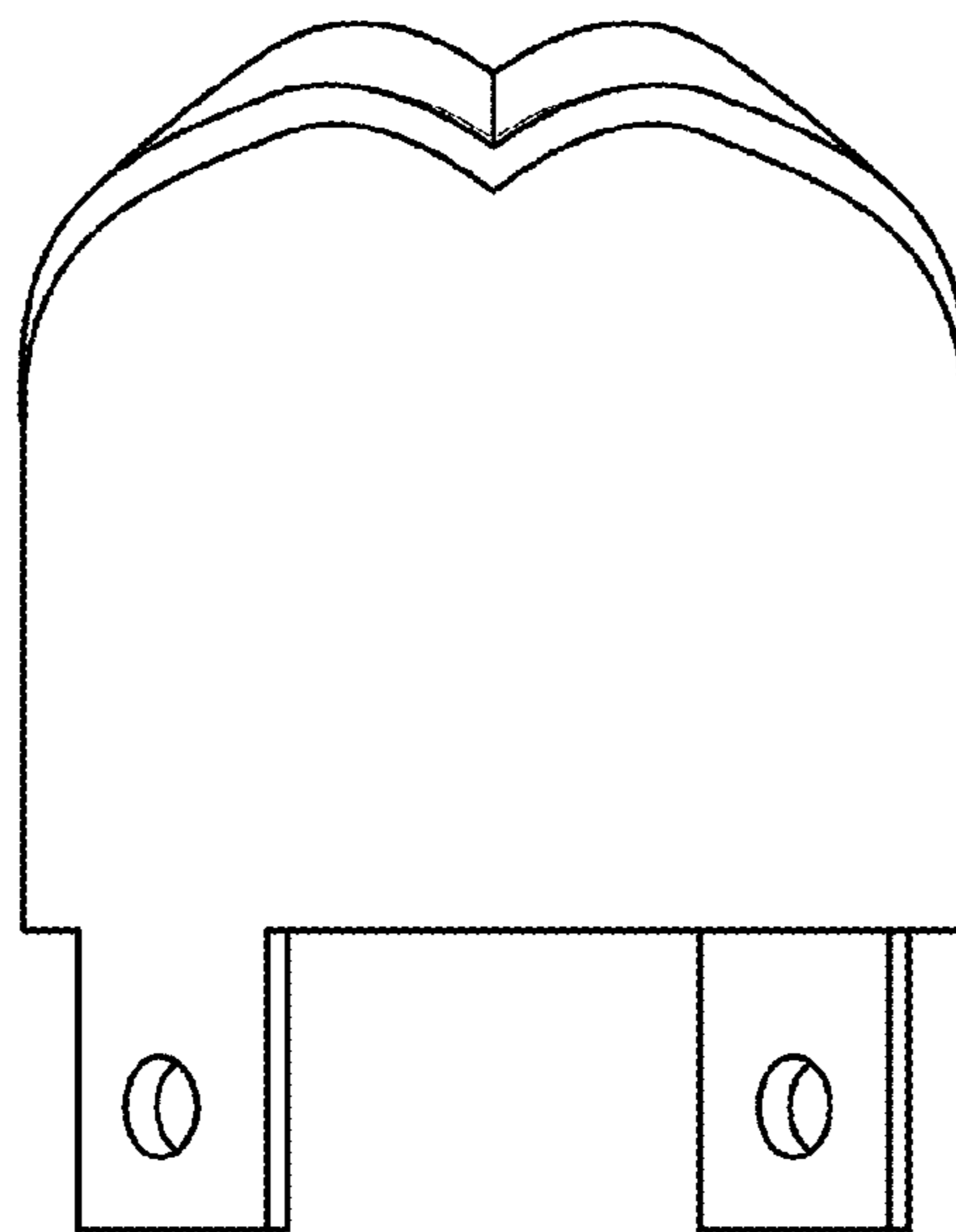

FIG. 8

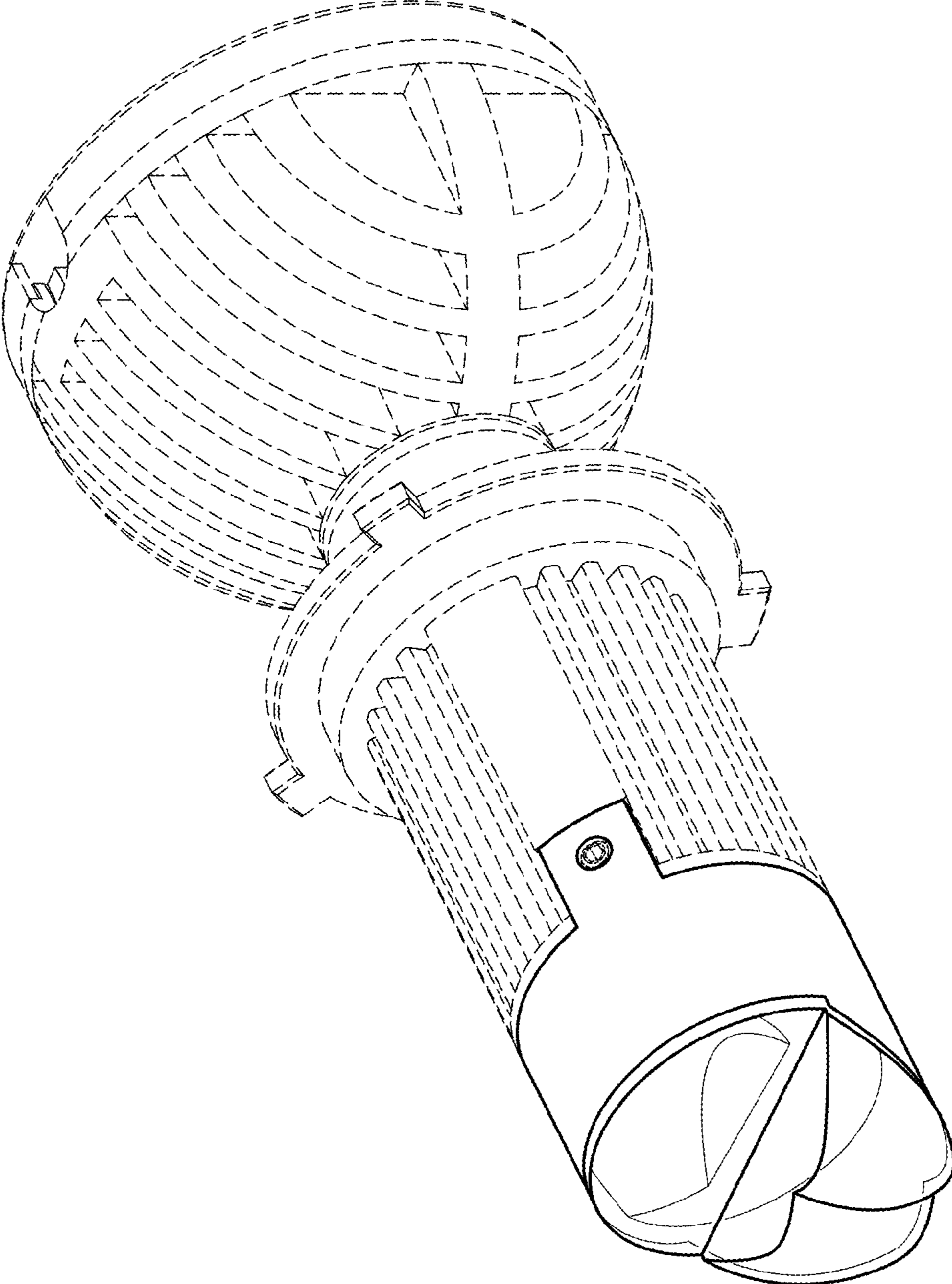

FIG.9