



US00D754249S

(12) **United States Design Patent**
Miyazawa

(10) **Patent No.:** **US D754,249 S**
(45) **Date of Patent:** **** Apr. 19, 2016**

(54) **FINISHER FOR AN IMAGE PRODUCING OFFICE MACHINE**

(71) Applicant: **Canon Kabushiki Kaisha**, Ohta-ku, Tokyo (JP)

(72) Inventor: **Yoshihiro Miyazawa**, Tokyo (JP)

(73) Assignee: **Canon Kabushiki Kaisha**, Tokyo (JP)

(**) Term: **14 Years**

(21) Appl. No.: **29/499,102**

(22) Filed: **Aug. 12, 2014**

(30) **Foreign Application Priority Data**

Feb. 20, 2014 (JP) 2014-003422

(51) **LOC (10) Cl.** **18-99**

(52) **U.S. Cl.**
USPC **D18/49**

(58) **Field of Classification Search**

USPC D18/49, 36, 37, 38, 39, 44, 46, 50, 53,
D18/54, 56, 59; D14/322, 422, 463, 468,
D14/469, 471, 493

CPC G06K 19/07749; G06K 19/0723;
G06K 19/041; G06K 19/07758; G06K
19/0775; G06K 19/07783; G06K 19/07794;
G06K 19/06046; G06K 19/07722; G06K
19/07773; G06K 19/07779; G06K 19/07784;
G06K 19/07786; G06K 19/0709; G06K
7/10178; G06K 7/10336; G06K 7/1096;
G06K 13/067; G06K 13/16; G06K 17/00;
G06K 17/0006; G06K 17/0022; G06K
17/0025; G06K 19/02; G06K 19/06; G06K
19/06028; G06K 19/0614; G06K 19/06206;
G06K 19/067

See application file for complete search history.

(56) **References Cited**

U.S. PATENT DOCUMENTS

D362,679	S	*	9/1995	Meister, Jr.	D18/49
D415,788	S	*	10/1999	Quijano	D18/49
D559,898	S	*	1/2008	Suzuki	D18/49
D567,848	S	*	4/2008	Kawamura	D18/39
D584,344	S	*	1/2009	Lee	D18/43
D632,295	S	*	2/2011	Kuroda	D14/422
D642,179	S	*	7/2011	Kuroda	D14/422
D685,411	S	*	7/2013	Tanaka	D18/49
D692,891	S	*	11/2013	Kuroda	D14/422
D738,956	S	*	9/2015	Larson	D18/49

* cited by examiner

Primary Examiner — Daniel Bui

Assistant Examiner — Khawaja Anwar

(74) *Attorney, Agent, or Firm* — Fitzpatrick, Cella, Harper & Scinto

(57) **CLAIM**

The ornamental design for a finisher for an image producing office machine, as shown and described.

DESCRIPTION

FIG. 1 is a front view of a finisher for an image producing office machine, such as a printer or copier showing my new design;

FIG. 2 is a rear view thereof;

FIG. 3 is a top plan view thereof;

FIG. 4 is a bottom plan view thereof;

FIG. 5 is a left side view thereof;

FIG. 6 is a right side view thereof; and,

FIG. 7 is a perspective view thereof.

The broken lines depict environmental subject matter only and form no part of the claimed design.

1 Claim, 5 Drawing Sheets

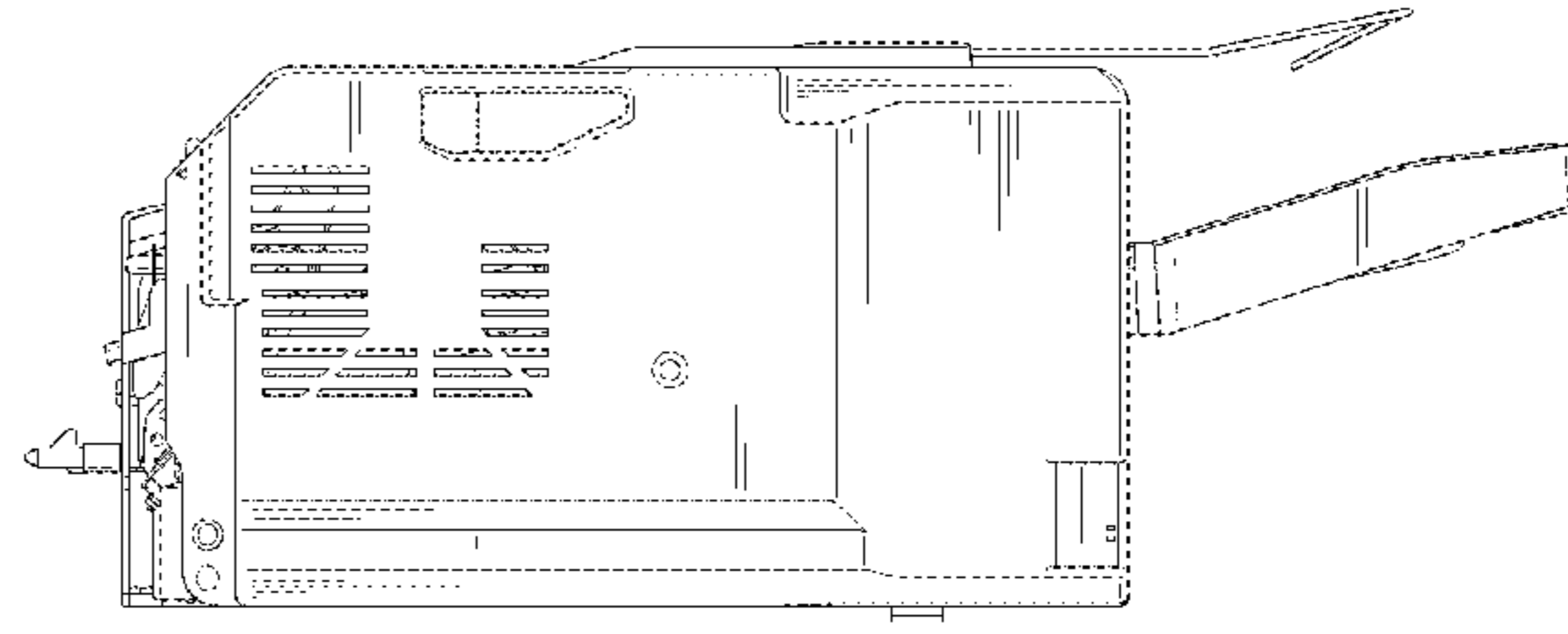
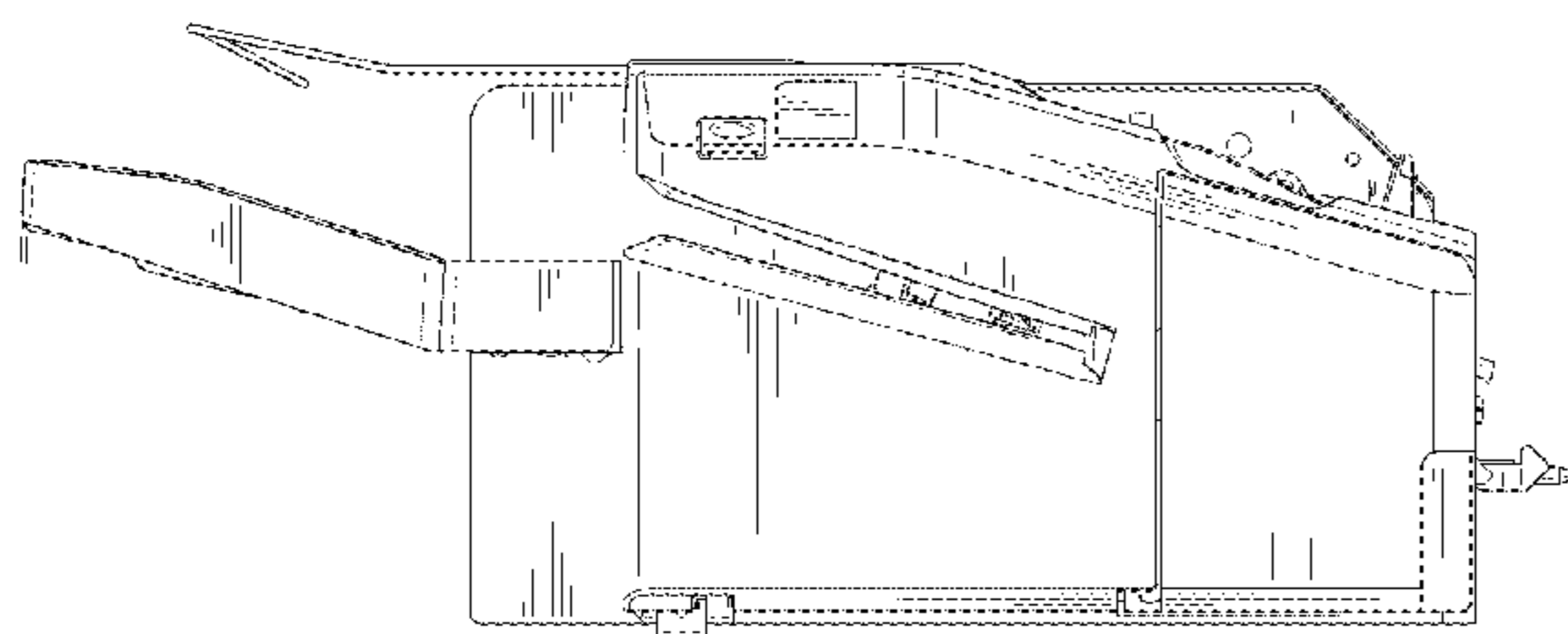

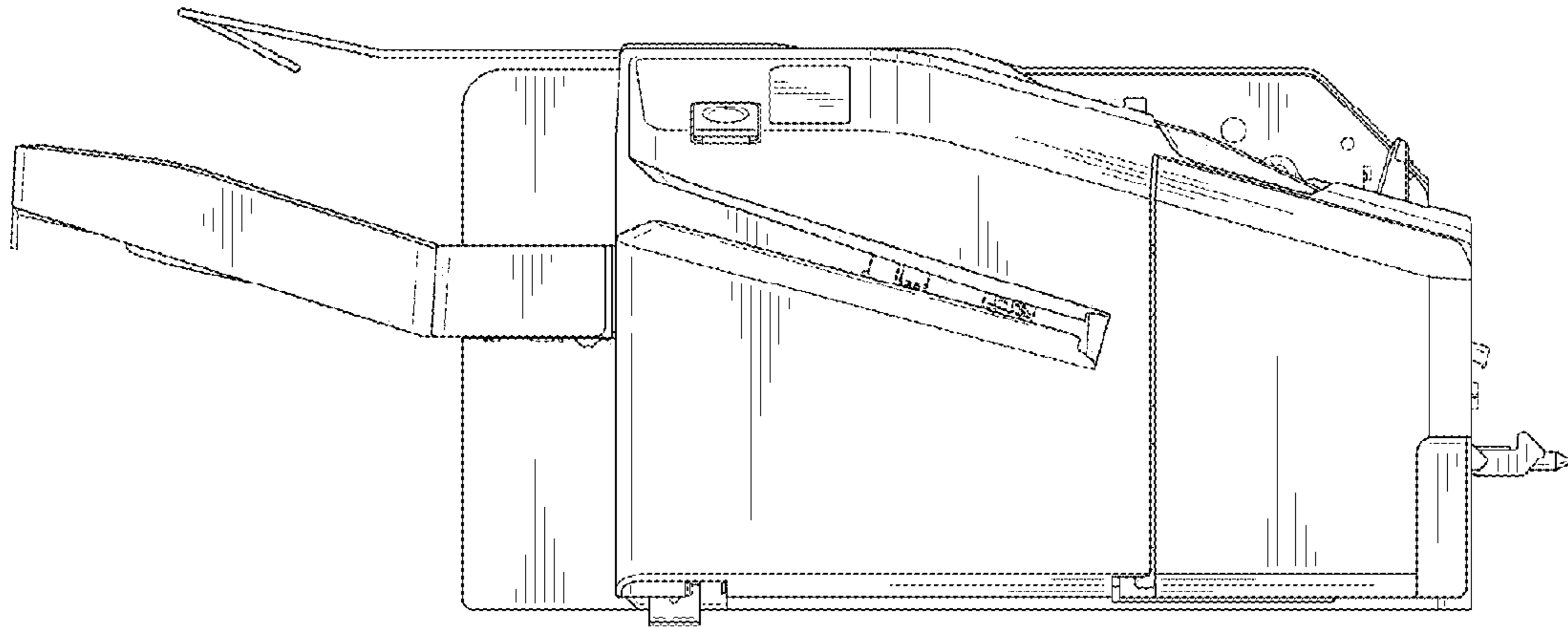

FIG. 1

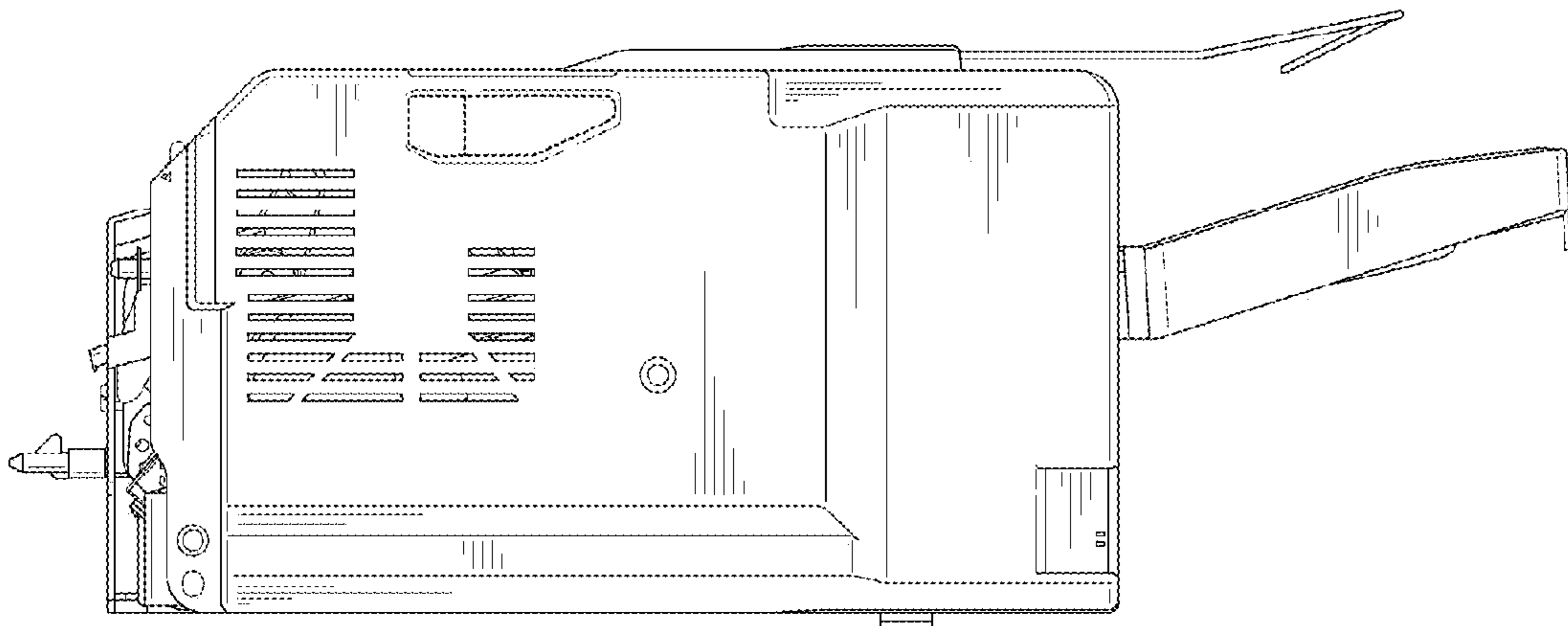

FIG. 2

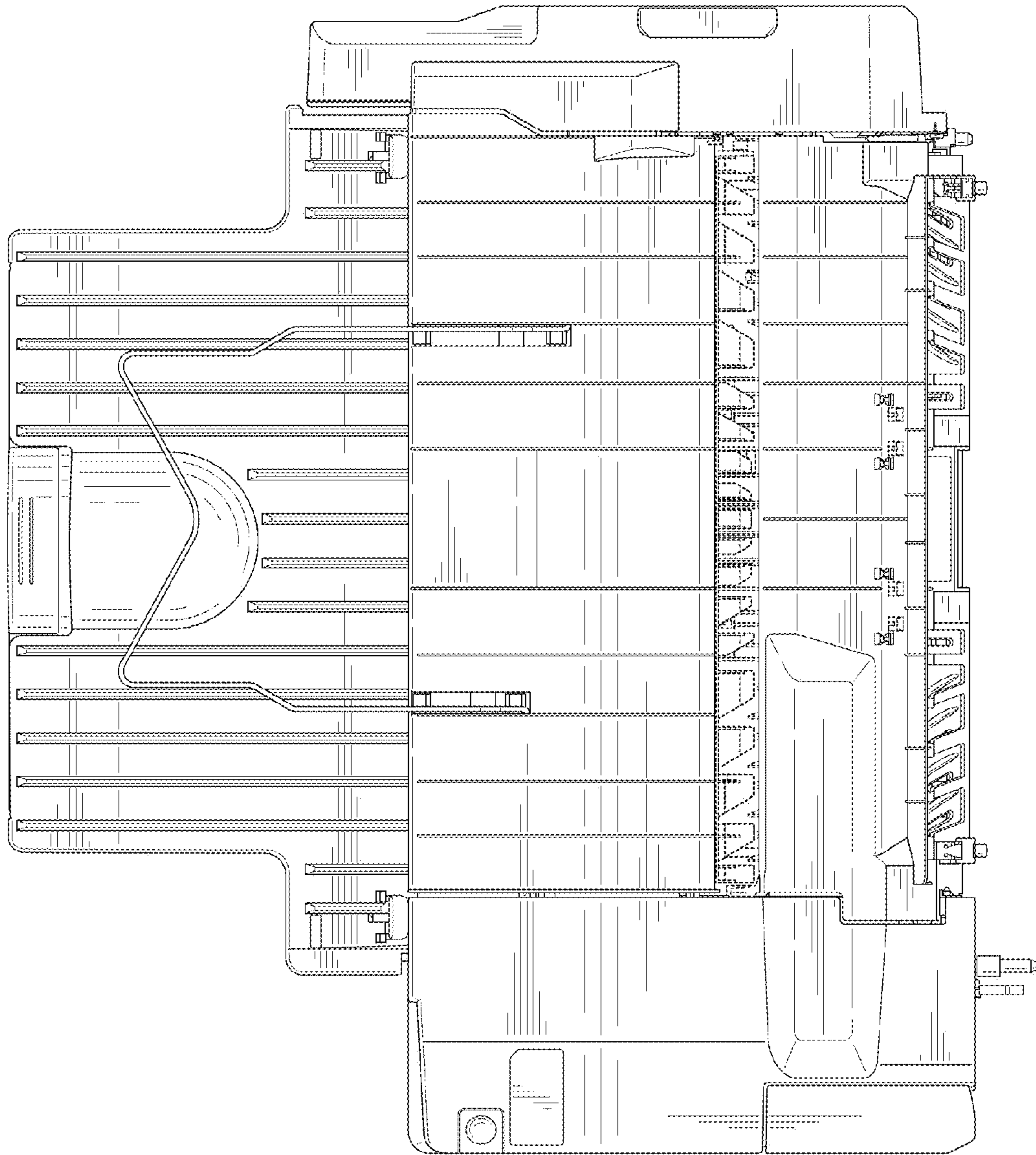

FIG. 3

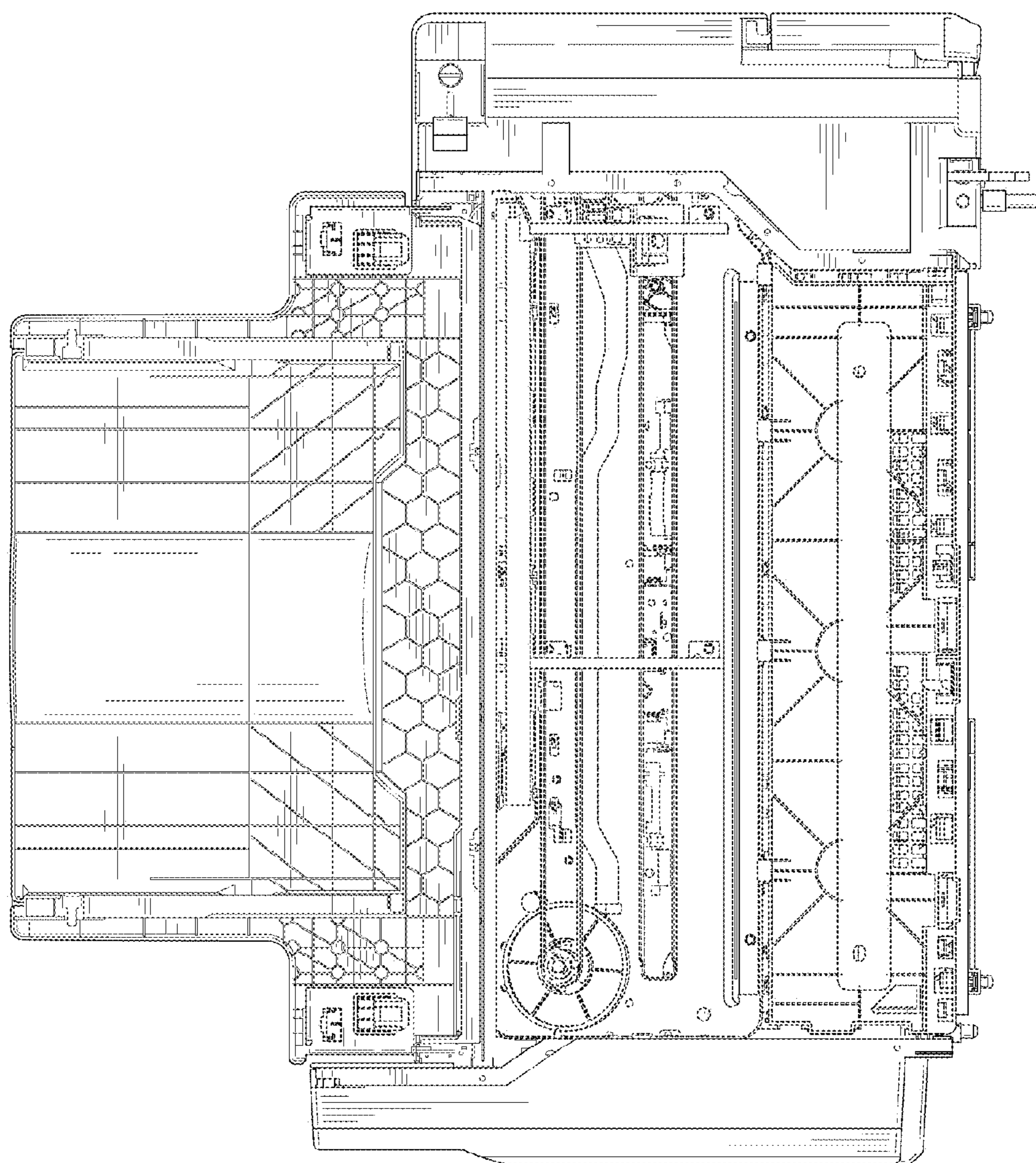

FIG. 4

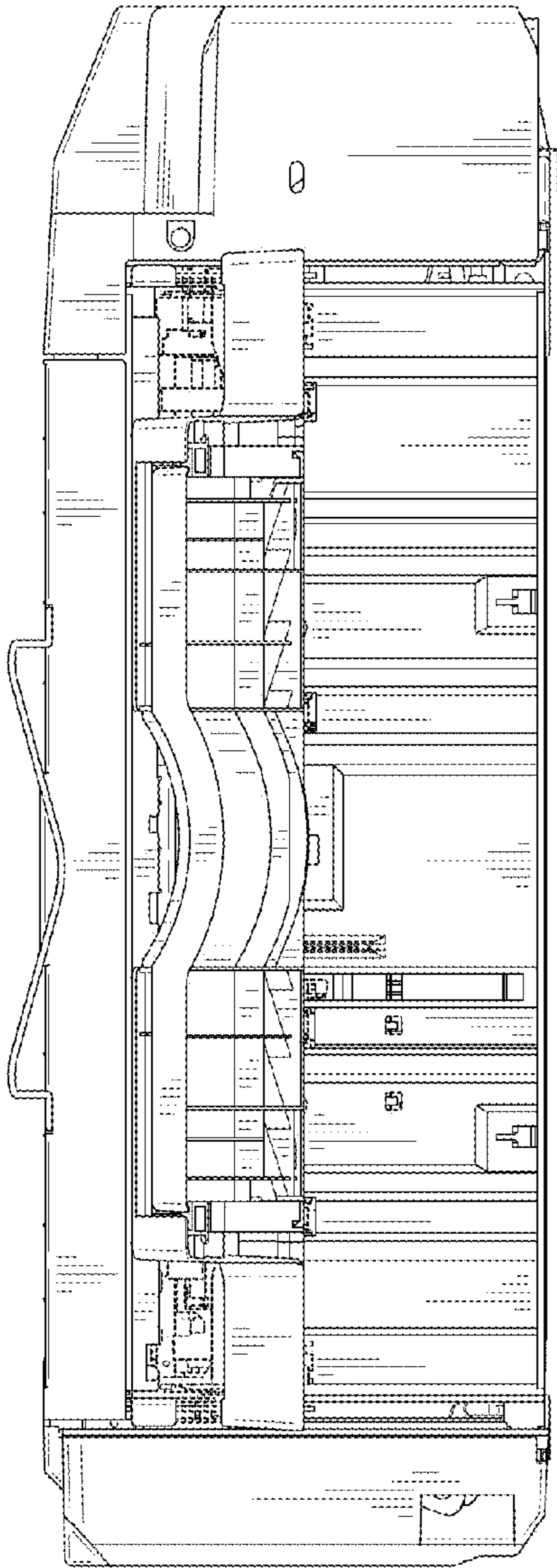

FIG. 5

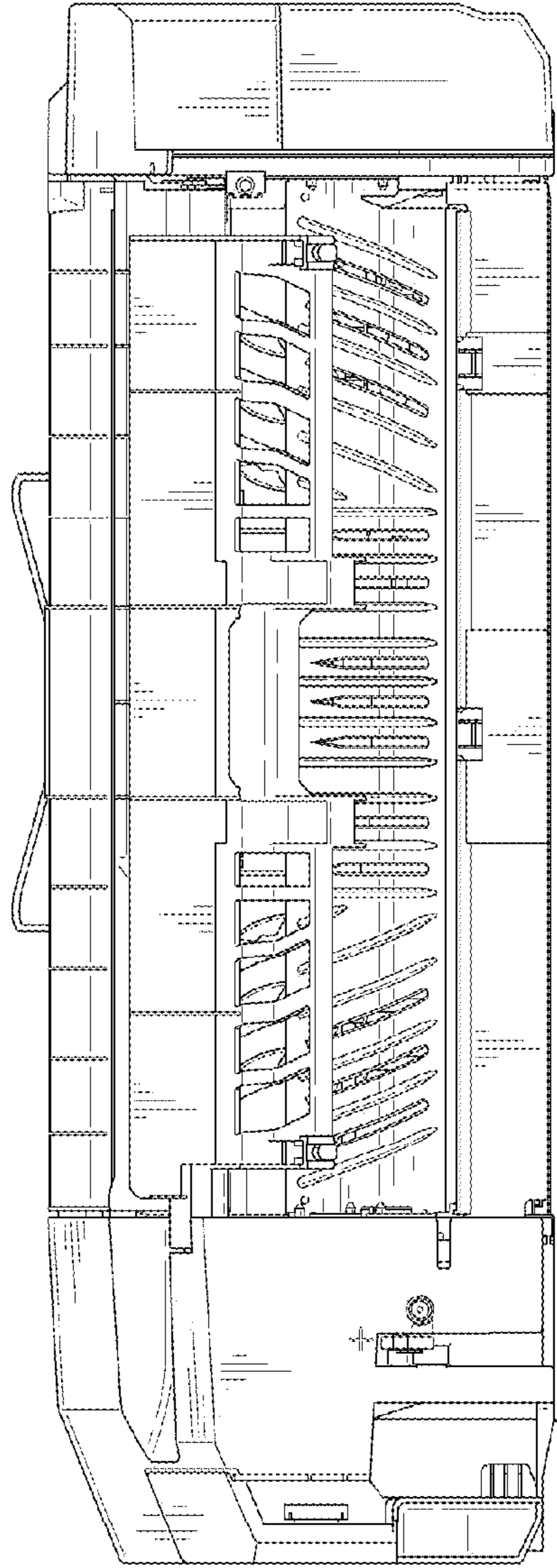

FIG. 6

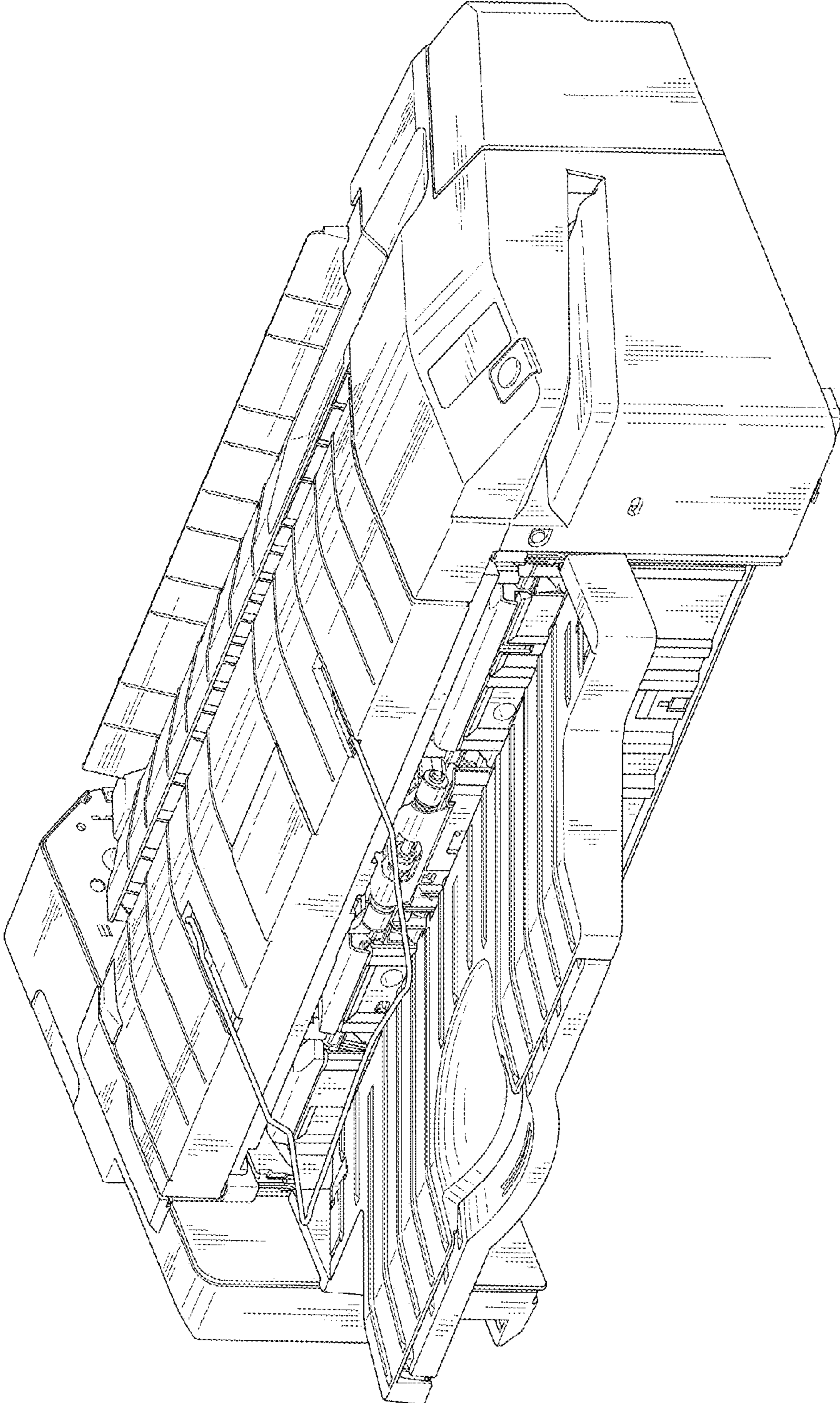

FIG. 7