



US00D754242S

(12) **United States Design Patent**  
**Wang**

(10) **Patent No.:** **US D754,242 S**

(45) **Date of Patent:** **\*\* Apr. 19, 2016**

(54) **CARRIER**

(71) Applicant: **SZ DJI TECHNOLOGY CO., LTD.**,  
Shenzhen (CN)

(72) Inventor: **Zhen Wang**, Shenzhen (CN)

(73) Assignee: **SZ DJI TECHNOLOGY CO., LTD.**,  
Shenzhen (CN)

(\*\*) Term: **14 Years**

(21) Appl. No.: **29/479,219**

(22) Filed: **Jan. 13, 2014**

(30) **Foreign Application Priority Data**

Dec. 24, 2013 (CN) ..... 2013 3 0643922

(51) **LOC (10) CL.** ..... **16-05**

(52) **U.S. CL.**  
USPC ..... **D16/242**

(58) **Field of Classification Search**

USPC ..... D16/205, 211, 214, 218–220, 237–250,  
D16/302, 303

CPC ..... G03B 15/041–15/0436; G03B  
17/561–17/568; G03B 21/20–21/2066; F16M  
11/10; F16M 11/14; F16M 11/26; F16M  
11/28; F16M 11/38; F16M 13/00; F16M  
13/04

See application file for complete search history.

(56) **References Cited**

U.S. PATENT DOCUMENTS

D292,982	S	*	12/1987	Nakatani	.....	D16/245
4,955,568	A	*	9/1990	O'Connor et al.	.....	248/183.3
D323,339	S	*	1/1992	Ishikawa	.....	D16/245
D564,010	S	*	3/2008	Dordick	.....	D16/242
D564,567	S	*	3/2008	Dordick	.....	D16/242
D630,240	S	*	1/2011	Torbitt	.....	D16/245
D653,692	S	*	2/2012	Dordick	.....	D16/242

OTHER PUBLICATIONS

The DJI Phantom 3 Is the Successor to the World's Most Popular Drone. [online] Published Apr. 8, 2015. Retrieved from URL: <<http://motherboard.vice.com/read/the-dji-phantom-3-is-the-successor-to-the-worlds-most-popular-drone>>.\*

\* cited by examiner

*Primary Examiner* — Susan Bennett Hattan

*Assistant Examiner* — Vy Koenig

(74) *Attorney, Agent, or Firm* — Novak Druce Connolly Bove + Quigg LLP

(57) **CLAIM**

The ornamental design for a carrier, as shown and described.

**DESCRIPTION**

FIG. 1 is a three-dimensional view of a carrier showing our design.

FIG. 2 is a front view thereof.

FIG. 3 is a rear view thereof.

FIG. 4 is a left side view thereof.

FIG. 5 is a right side view thereof.

FIG. 6 is a top view thereof; and,

FIG. 7 is a bottom view thereof.

The broken lines throughout all the drawings represent portions of the carrier that form no part of the claimed design.

**1 Claim, 7 Drawing Sheets**

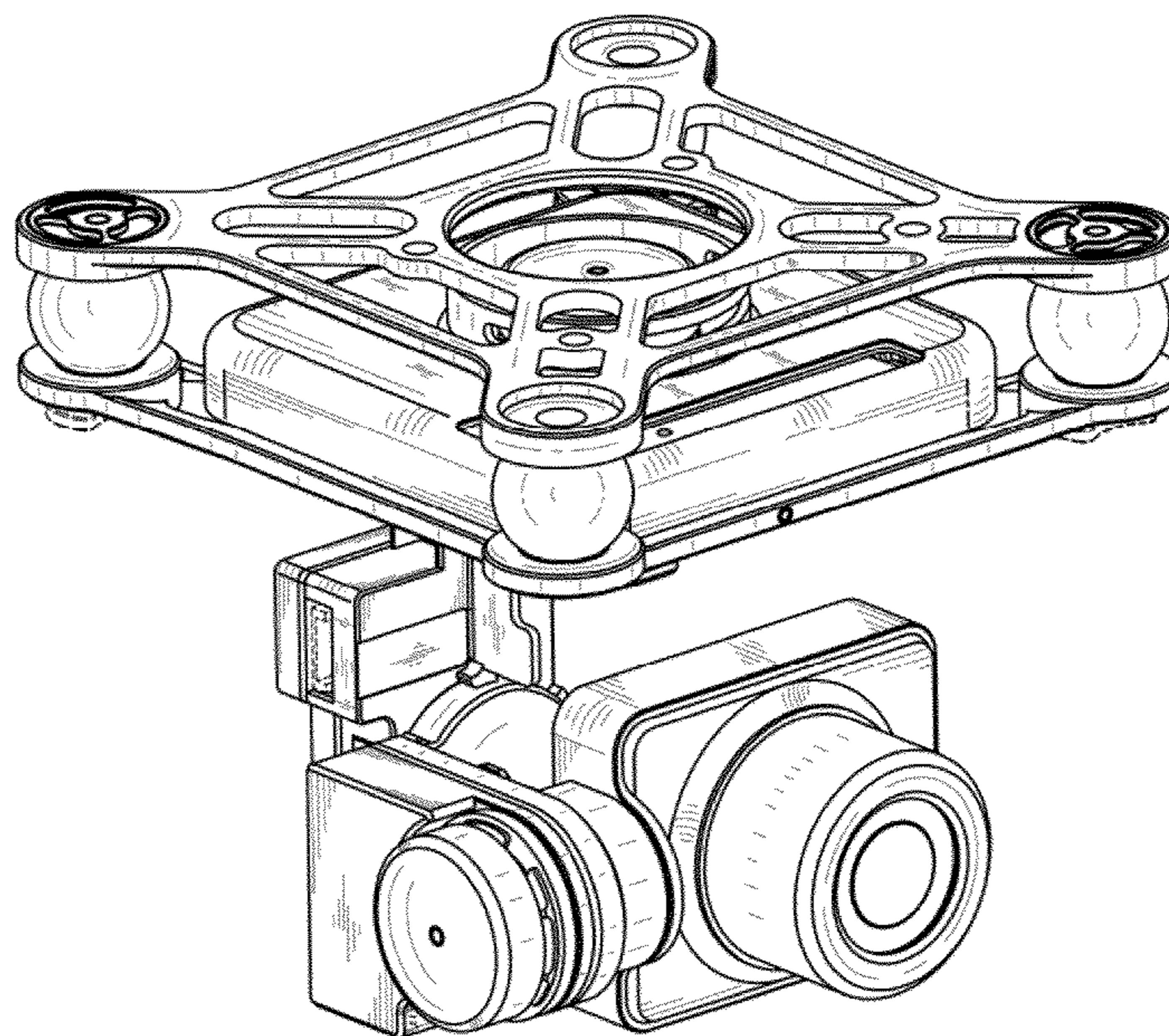

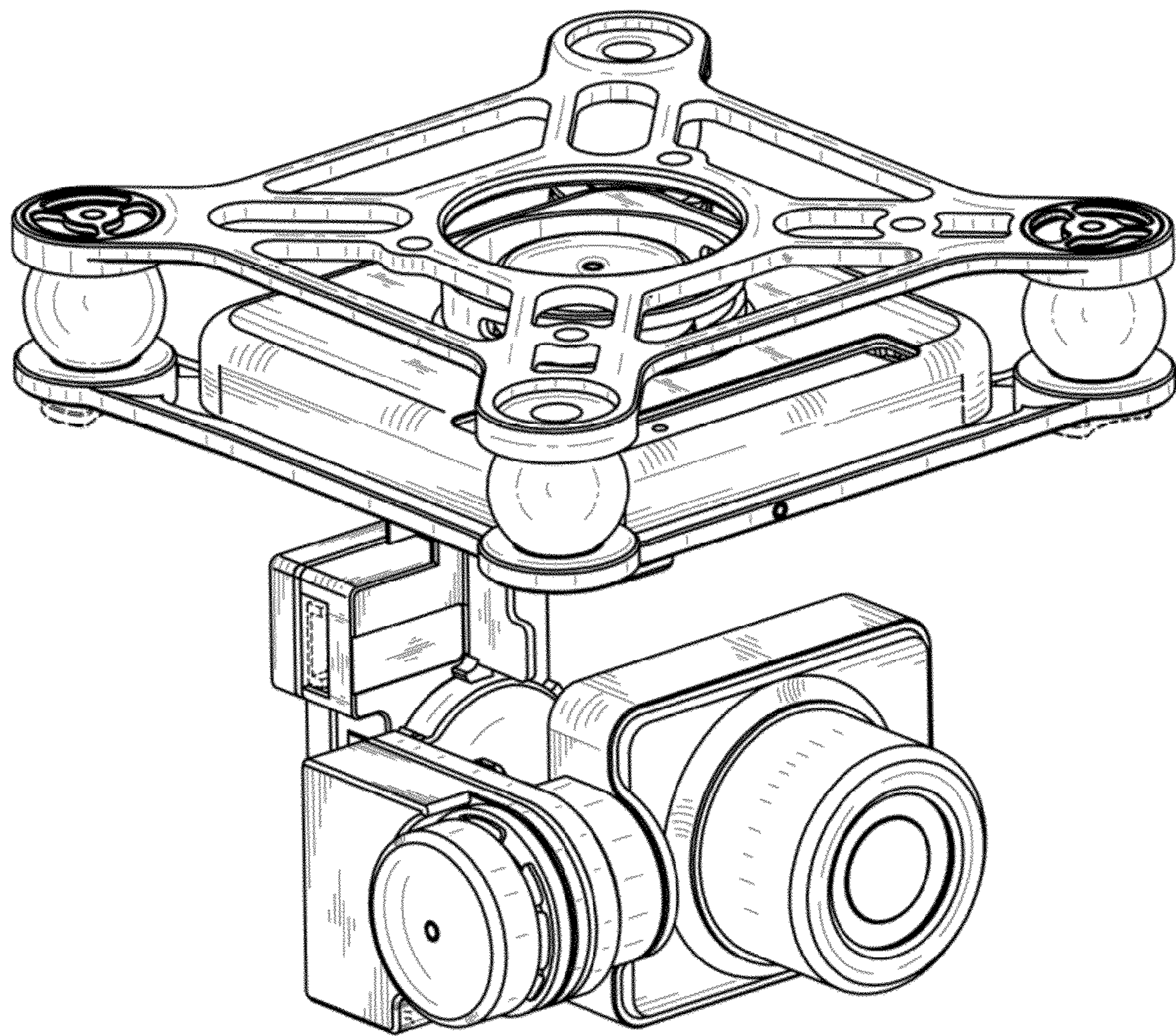

FIG. 1

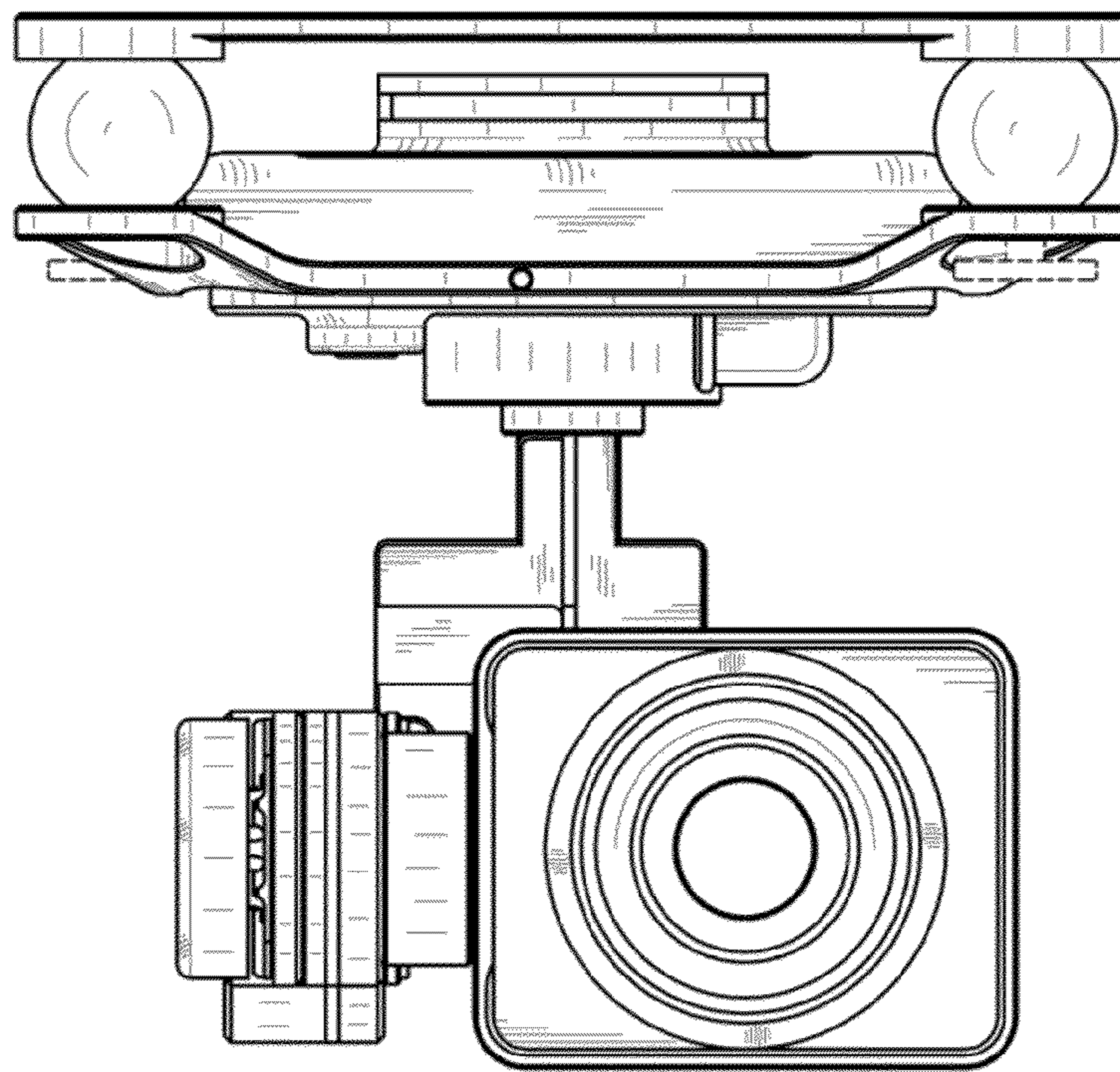

FIG. 2

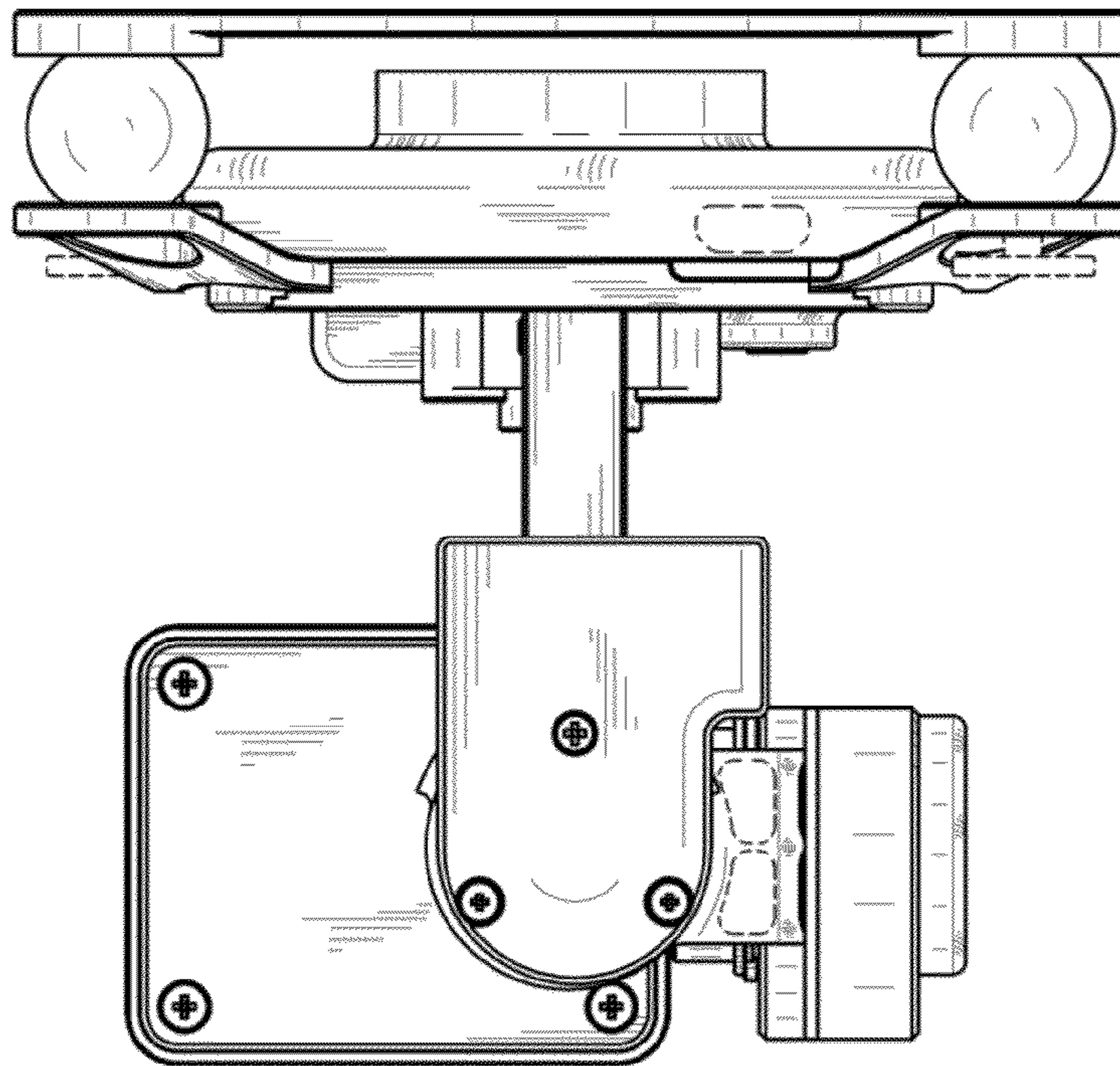

FIG. 3

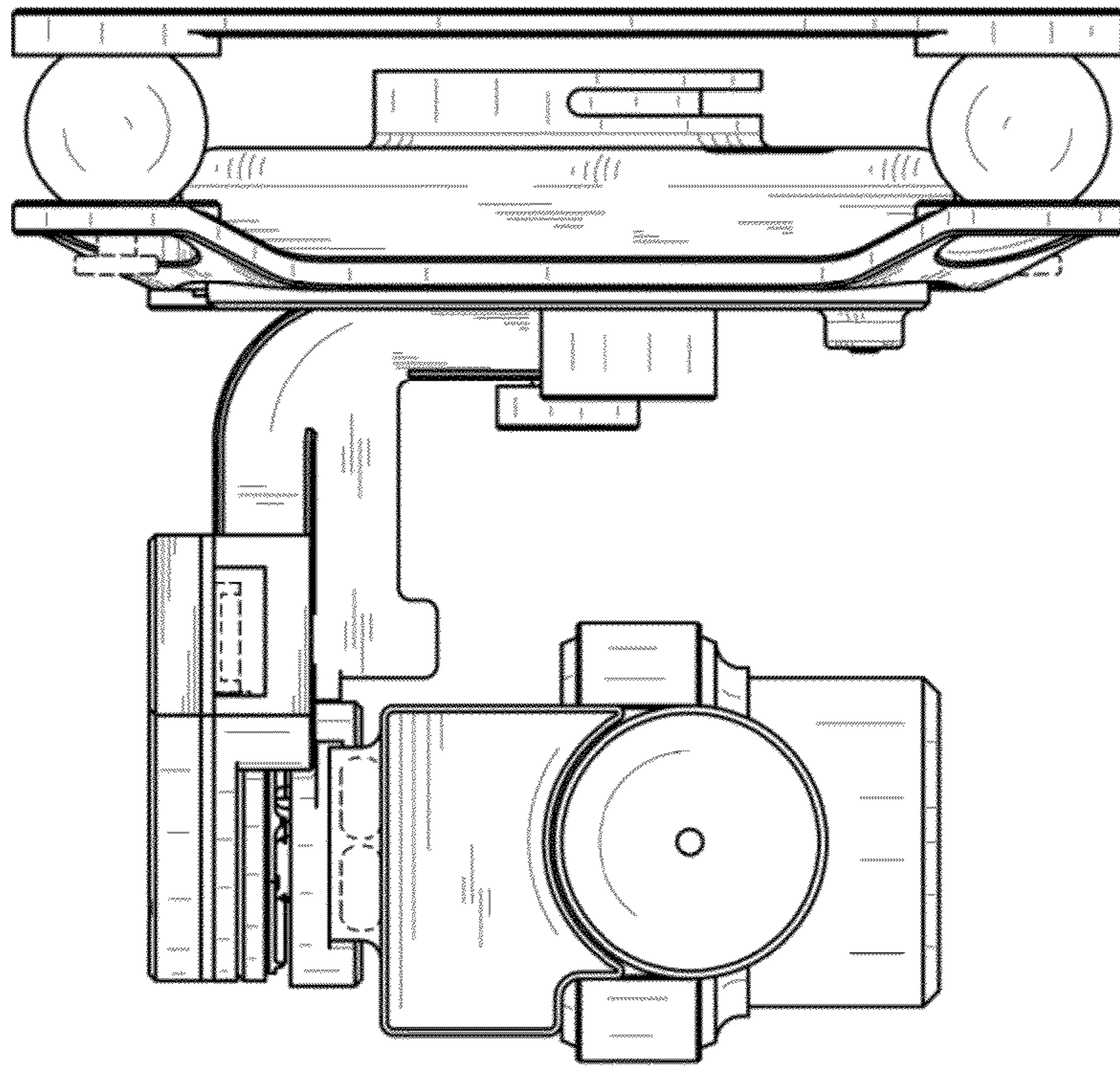

FIG. 4

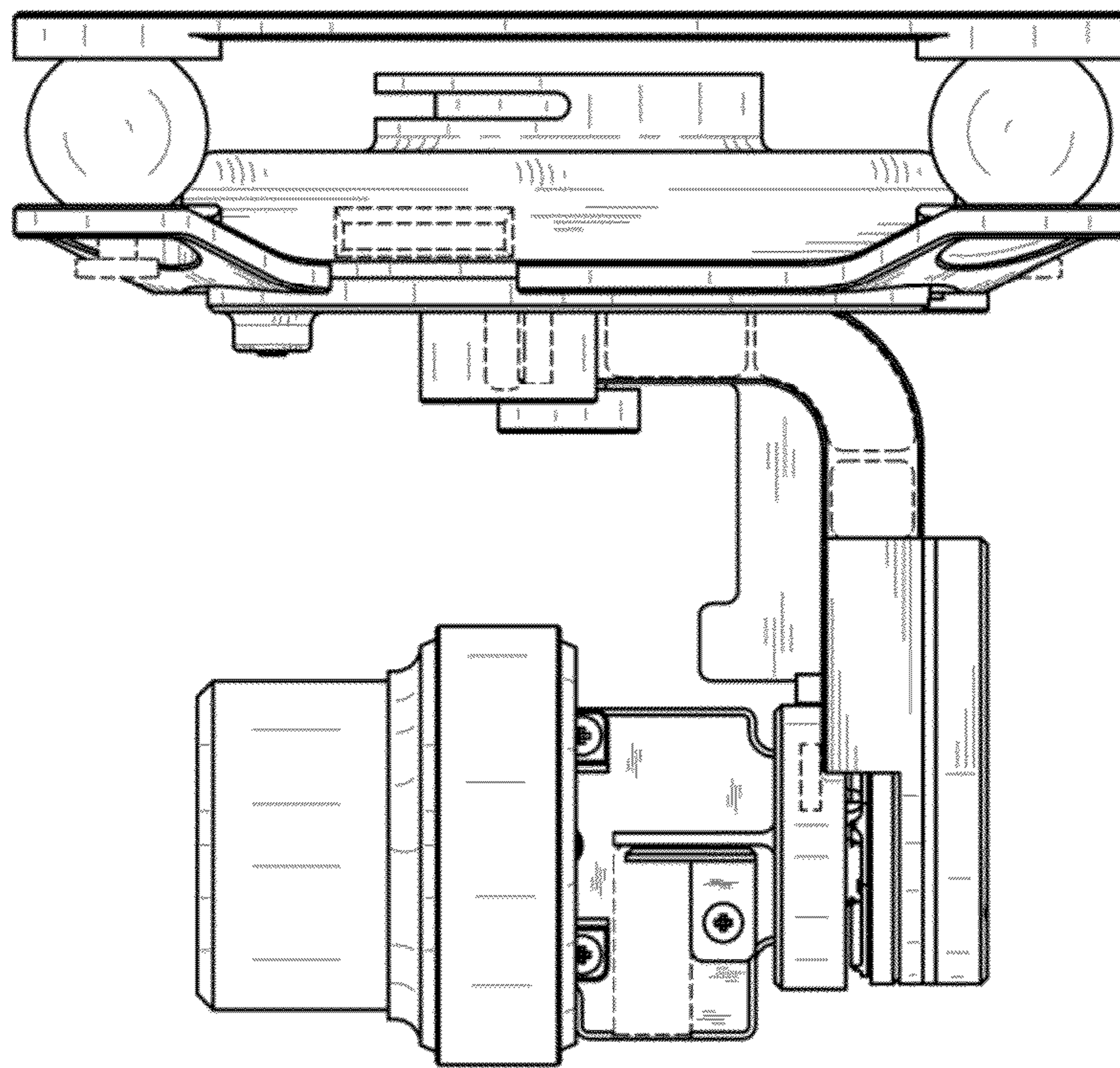
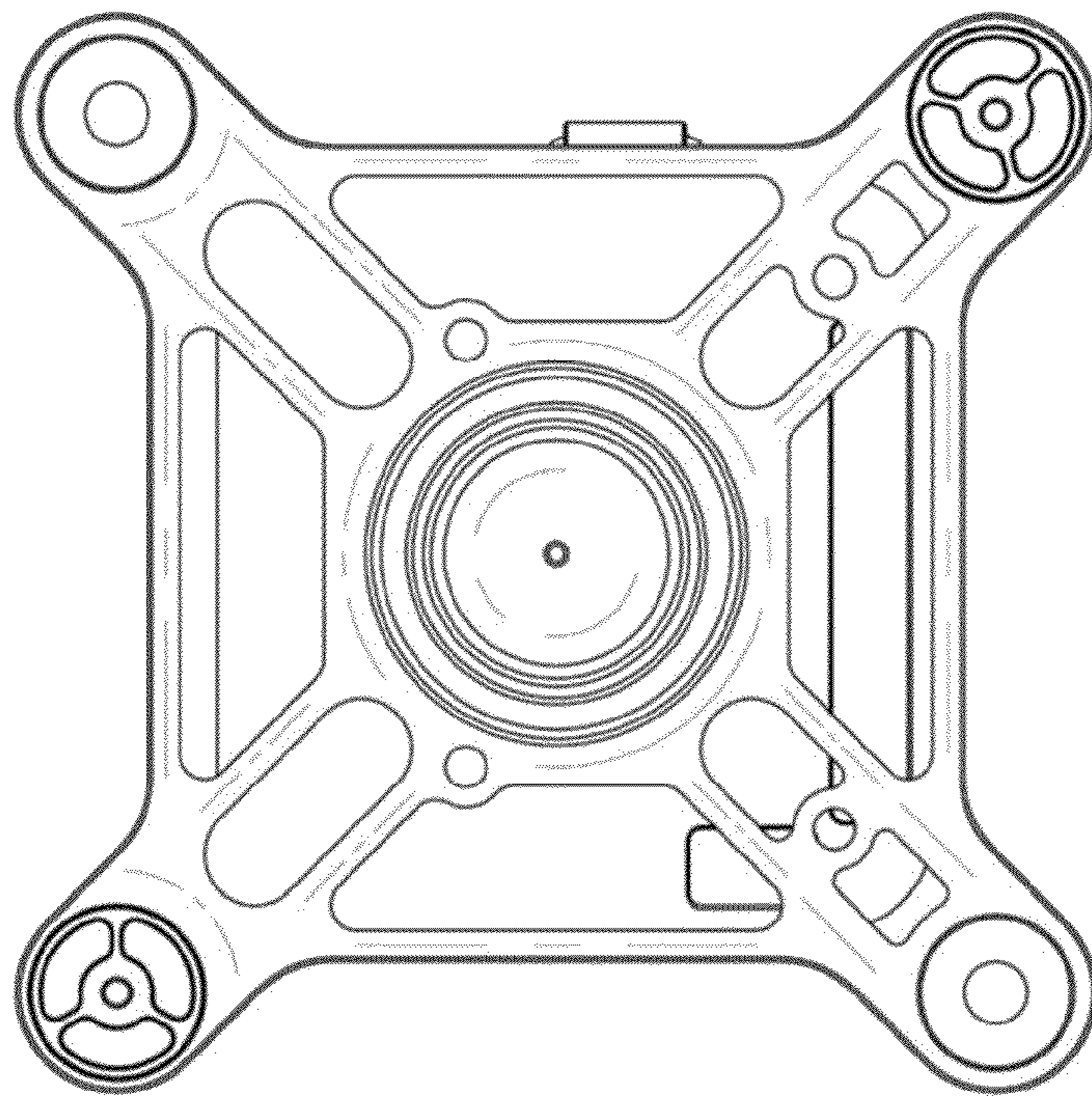

FIG. 5



*Fig. 6*

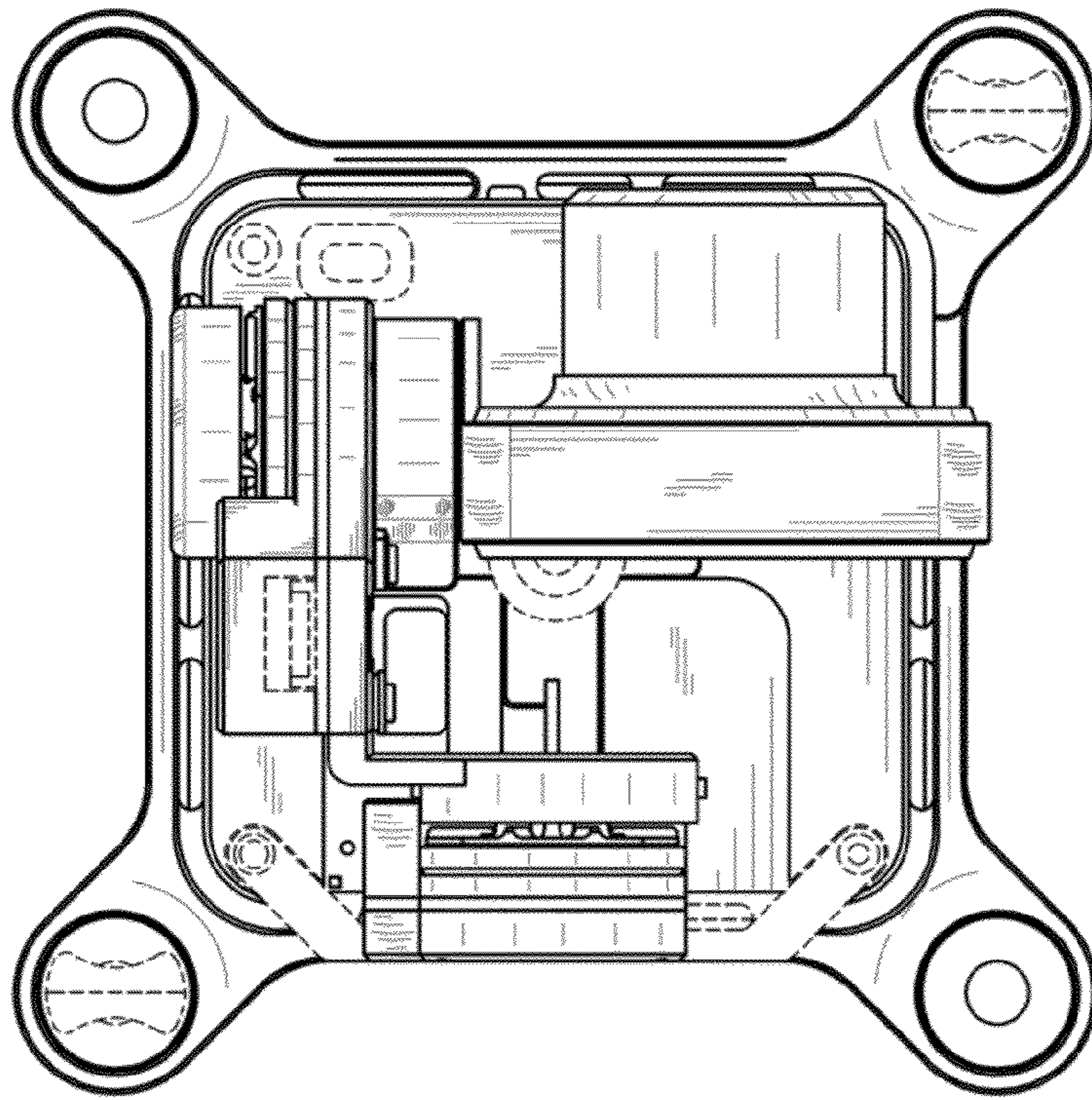

FIG. 7